



# 225

## **WEIGHT INDICATOR**

### **Installation and Technical Manual**

8200-M698-O1 Rev A  
11/13

PO BOX 151 • WEBB CITY, MO 64870  
PH (417) 673-4631 • FAX (417) 673-5001  
[www.cardinalscales.com](http://www.cardinalscales.com)



Printed in USA

Technical Support: Ph: 866-254-8261 • [techsupport@cardet.com](mailto:techsupport@cardet.com)



# INTRODUCTION

Thank you for selecting and purchasing the Cardinal Model 225 Weight Indicator. The Model 225 indicator was built with quality and reliability at our factory in Webb City, Missouri and incorporates the latest in digital technology and innovative features for the weighing industry. Configuration and upgrades can easily be performed in the field, while still maintaining the rigid control the most demanding installations require. This flexibility insures the Model 225 will be able to meet your weight indicating needs for years to come.

The purpose of this manual is to provide you with a guide through installation, setup and calibration of your new Model 225 Weight Indicator. Please read it thoroughly before attempting to install your indicator and keep it handy for future reference.

# COPYRIGHT

All rights reserved. Reproduction or use, without expressed written permission, of editorial or pictorial content, in any manner, is prohibited. No patent liability is assumed with respect to the use of the information contained herein.

# DISCLAIMER

While every precaution has been taken in the preparation of this manual, the Seller assumes no responsibility for errors or omissions. Neither is any liability assumed for damages resulting from use of the information contained herein. All instructions and diagrams have been checked for accuracy and ease of application; however, success and safety in working with tools depend to a great extent upon the individual accuracy, skill and caution. For this reason, the Seller is not able to guarantee the result of any procedure contained herein. Nor can they assume responsibility for any damage to property or injury to persons occasioned from the procedures. Persons engaging the procedures do so entirely at their own risk.

SERIAL NUMBER _____
DATE OF PURCHASE _____
PURCHASED FROM _____
_____
_____
RETAIN THIS INFORMATION FOR FUTURE USE

# PRECAUTIONS

Before using this indicator, read this manual and pay special attention to all "NOTIFICATION" symbols:



**IMPORTANT**



**ELECTRICAL  
WARNING**



**STATIC  
SENSITIVE**

## FCC COMPLIANCE STATEMENT

This equipment generates uses, can radiate radio frequency, and if not installed and used in accordance with the instruction manual, may cause interference to radio communications. It has been tested and found to comply with the limits for a Class A computing device pursuant to Subpart J of Part 15 of FCC rules, which are designed to provide reasonable protection against such interference when operated in a commercial environment. Operation of this equipment in a residential area may cause interference in which case the user will be responsible to take whatever measures necessary to correct the interference.

You may find the booklet "How to Identify and Resolve Radio TV Interference Problems" prepared by the Federal Communications Commission helpful. It is available from the U.S. Government Printing Office, Washington, D.C. 20402, stock No. 001-000-00315-4.

## PROPER DISPOSAL

When this device reaches the end of its useful life, it must be properly disposed of. It must not be disposed of as unsorted municipal waste. Within the European Union, this device should be returned to the distributor from where it was purchased for proper disposal. This is in accordance with EU Directive 2002/96/EC. Within North America, the device should be disposed of in accordance with the local laws regarding the disposal of waste electrical and electronic equipment.

It is everyone's responsibility to help maintain the environment and to reduce the effects of hazardous substances contained in electrical and electronic equipment on human health. Please do your part by making certain that this device is properly disposed of. The symbol shown to the right indicates that this device must not be disposed of in unsorted municipal waste programs.



## CAUTION



**CAUTION:** RISK OF EXPLOSION IF BATTERY IS REPLACED BY AN INCORRECT TYPE. DISPOSE OF USED BATTERIES ACCORDING TO THE INSTRUCTIONS.

**ATTENTION:** RISQUE D'EXPLOSION SI LA BATTERIES EST REMPLAC'E PAR UN TYPE INCORRECT. REJETEZ LES BATTERIES UTILISE'ES SELON LES INSTRUCTIONS.

# TABLE OF CONTENTS

SPECIFICATIONS	Page 1
FEATURES	Page 2
PRECAUTIONS	Page 3
Static Electricity	Page 3
SITE PREPARATION	Page 5
Environmental	Page 5
Electrical power	Page 6
Electrical Noise Interference	Page 6
Transient Suppression	Page 6
RFI Immunity	Page 7
INSTALLATION	Page 9
Mounting	Page 9
Load Cell Connections	Page 10
Load Cell Cable Connection with RFI Suppression	Page 10
Load Cell Cable Connection <u>without</u> RFI Suppression	Page 13
Load Cell Connections with Over 30 Feet of Cable	Page 13
Serial I/O Cable Installation	Page 14
Serial Ports Specifications (Continuous or On Demand Output)	Page 15
USB Interface and USB Cable Installation	Page 17
I/O Ports Interconnections	Page 19
Optically Isolated Remote Inputs	Page 21
AC Input Relay Board(s)	Page 21
Preset Weight Comparator/Checkweigher Logic Level Output	Page 23
AC Output Relay Board(s)	Page 23
DC Output Relay Board(s)	Page 26
RB4C Relay J-Box	Page 29
Main PC Board I/O Functions Table	Page 30
Relay Box Cable Wire Number to Relay Number Table	Page 30
MAIN PCB	Page 31
Main PCB Jumpers	Page 32
RE-INSTALLING THE REAR PANEL	Page 33
KEYPAD FUNCTIONS	Page 34
Standard Function Keys	Page 34
Alphanumeric Keys	Page 37
Shift Key Combinations	Page 38
Soft Keys	Page 40

# TABLE OF CONTENTS, CONT.

ANNUNCIATORS	Page 41
TIME, DATE AND CONSECUTIVE NUMBER	Page 43
DISPLAY CONTRAST ADJUSTMENT	Page 44
CALIBRATION AND SETUP	Page 45
Security Seals	Page 45
ENTER CALIBRATION AND SETUP	Page 47
SETUP MENU #1	Page 47
SETUP MENU #2	Page 52
SERIAL INPUT/OUTPUT SETUP	Page 52
DIO SETUP (PWC Status)	Page 62
PRINT TABS SETUP	Page 64
SETUP SCALE	Page 70
Filter Setting Recommendations	Page 75
CALIBRATE	Page 78
CALIBRATION METHODS	Page 79
CALIBRATION MODES	Page 79
Multi-Point Calibration	Page 81
Dual-Point with Zero (First Zero) Calibration	Page 82
Dual-Point <u>without</u> Zero (False Zero) Calibration	Page 83
Single-Point for Span Only (Last Zero) Calibration	Page 83
Single-Point for Zero Only (Only Zero) Calibration	Page 84
Fine Span Adjustment (During Calibration)	Page 85
High Resolution Adjustment (During Calibration)	Page 85
Calibration Parameters	Page 86
Calibration "C" Numbers	Page 87
SETUP MENU #3	Page 88
ACCUMULATORS	Page 88
BACK LIGHT	Page 88
PASSWORD	Page 89
2XX- (2XX OPTION CARD)	Page 89
BADGE READER	Page 90
KEY LOCKOUT	Page 92
LOCAL REMOTE PORT	Page 93

## TABLE OF CONTENTS, CONT.

ID STORAGE SETUP (Mode of Operation = 1)	Page 94
PRESET WEIGHT COMPARATORS SETUP (Mode of Operation = 3)	Page 96
COUNT OPERATION	Page 98
ID STORAGE OPERATION	Page 99
PRESET WEIGHT COMPARATORS OPERATION	Page 112
ACCUMULATORS	Page 115
CONTINUOUS OUTPUT FORMATS	Page 119
ASCII COMMANDS	Page 125
TROUBLESHOOTING	Page 127
Error Codes	Page 127
Before You Call Service	Page 130
TEST MODE AND DIAGNOSTIC DISPLAY	Page 131
ERASING MEMORY	Page 133
FINE SPAN ADJUSTMENT	Page 135
HIGH RESOLUTION ADJUSTMENT	Page 135
VIEW AUDIT TRAIL COUNTERS	Page 136
ELECTRONIC TALLEY ROLL (ETR) FILE	Page 137
DELETING CUSTOM TICKETS	Page 139
PRINT SETUP	Page 140
LEAD AND WIRE SECURITY SEAL INSTALLATION	Page 141
PART IDENTIFICATION	Page 142





## SPECIFICATIONS

Power Requirements:	100 to 240 VAC (50/60 Hz) at 0.4A Max.
Enclosure Type:	Stainless Steel wall or desk-mount
Enclosure Size:	10 7/8"W x 8 3/16"H x 3 1/8"D (276mm W x 208mm H x 79mm D)
Weight:	9.2lbs ( <i>Size and Weight DOES NOT include Gimbal</i> )
Operating Environment:	Temperature: 14 to 104 °F (-10 to +40 °C) Humidity: 90% non-condensing (maximum)
Display:	240 x 64 (5" x 1.33") Graphics LCD w/ LED Backlight
Transducer Excitation:	12 VDC
Signal Input Range:	1.0 mV min. to 40 mV max. (with dead load boost)
Scales	1 ea Standard, 3 ea with optional 225-DS Dual Scale Input Board
Number of Load Cells:	14 each, 350-ohm load cells
Load Cell Cable Length:	1,500 feet maximum (requires the use of sense lines). Consult factory for other requirements 30 feet maximum without sense lines
Division Value:	Commercial: 1, 2, or 5 x 10, 1, 0.1, 0.01, 0.001 and 0.0001 Non-commercial: 0 to 99
Sensitivity:	
NON-COMMERCIAL	0.15 uV/e
NTEP	0.3uV/e (Class III/IIIL)
CANADA	0.3uV/e (Class III/IIHHD)
OIML	0.7 uV/e (Class III)
Scale Divisions:	
NON-COMMERCIAL	100 to 240,000
NTEP	100 to 10,000 (Class III/IIIL)
CANADA	100 to 10,000 (Class III/IIHHD)
OIML	100 to 10,000 (Class III)
Internal Resolution:	1 part in 16,777,216
Tare Capacity:	Six Digits (999,999)
Sample Rate:	1 to 100 samples per second, selectable
Auto Zero Range:	0.5 or 1 through 9 divisions
Weighing Units:	Tons, Pounds, Ounces, Tonnes "Metric Tons", Kilograms, Grams,
Keypad:	Membrane type with 60 color-coded keys
Standard I/O:	4 ea Serial I/O Ports configured as: 3 ea bi-directional RS-232 ports or 3 ea 20mA output-only ports 1 ea bi-directional 20mA port 1 ea output only RS-232/20mA port 8 ea Remote Isolated Inputs 16 ea Remote Isolated Outputs

# FEATURES

## Standard

- Time and Date with selectable 12 or 24 hour operation
- 200 ID Storage with an additional 100 temporary ID's
- Count Feature with accumulator
- StableSENSE<sup>®1</sup> adjustable digital filtering
- Multi-Point Calibration and High-Resolution Mode
- Selectable Key Disable
- Gross, Tare and Net Conversion
- Multi-Interval (Dual Range) Feature for Single or Multiple Scales
- Gross, Net, 32 ID, 8 Bin and Piece Count Accumulators
- Push Button and Keypad Tare Function
- 8 Preset Weight Comparators
- Checkweigher (3 or 5 Zone, Setup Selectable)
- Digital Fill Control (Single ingredient, 1 or 2 Speed with Static or Dynamic Trim)
- Batcher (Up to 15 Ingredient/bins, 1 Speed, or up to 7 Ingredient/bins, 2 Speed with Static or Dynamic Trim)
- 6 Programmable Print Formats Using *nControl*
- SMA Level 2 Compliant Serial Communications (See [www.scalemanufacturers.org](http://www.scalemanufacturers.org))
- Color-coded keypad with Alpha-Numeric, Special Function "Soft" and Navigation Keys
- Remote Input of Gross, Net, Tare, Print, Zero, Start Stop and Dump Commands
- USB Interface

## Optional

Allen-Bradley Interface\*

Analog Output (Digital to Analog Converter)\*

ControlNet Interface\*

DeviceNet Interface\*

Dual Scale\*

Ethernet Interface\*

Ethernet/IP Interface\*

Additional Serial Port (RS-232 or Plastic or Glass Fiber Optic) \*

802.11 Wi-Fi\*

Check Weigher Light Bar\*

External Relay Box\*

\*These feature requires additional hardware and includes additional documentation.

<sup>1</sup> StableSENSE<sup>®</sup> is a digital filter utilizing proprietary software algorithms to remove or greatly reduce changes in the weight display resulting from movement on the scale platform. StableSENSE<sup>®</sup> can be used with livestock and single animal scales to lessen the effects of the animal's movement on the scale or it can be used with vehicle scales to lessen the effects of wind and vehicle vibration. Any application affected by vibration or movement on the scale platform can benefit using StableSENSE<sup>®</sup>.

# PRECAUTIONS

## Static Electricity



**CAUTION!** This device contains static sensitive circuit cards and components. Improper handling of these devices or printed circuit cards can result in damage to or destruction of the component or card. Such actual and/or consequential damage **IS NOT** covered under warranty and is the responsibility of the device owner. Electronic components must be handled only by qualified electronic technicians who follow the guidelines listed below.



**WARNING!** ALWAYS use a properly grounded wrist strap when handling, removing or installing electronic circuit cards or components. Make certain that the wrist strap ground lead is securely attached to an adequate ground. If you are uncertain of the quality of the ground, you should consult a licensed electrician.



**ALWAYS** handle printed circuit card assemblies by the outermost edges. **NEVER** touch the components, component leads or connectors. **ALWAYS** observe warning labels on static protective bags and packaging and never remove the card or component from the packaging until ready for use. **ALWAYS** store and transport electronic printed circuit cards and components in anti-static protective bags or packaging.



# SITE PREPARATION REQUIREMENTS

The Model 225 Weight Indicator is a precision weight-measuring instrument. As with any precision instrument, it requires an acceptable environment to operate at its peak performance and reliability. This section is provided to assist you in obtaining such an environment.

## Environmental

The Model 225 Weight Indicator meets or exceeds all certification requirements within a temperature range of 14 to 104 °F (-10 to +40 °C).

In order to keep cooling requirements to a minimum, the indicator should be placed out of direct sunlight and to provide adequate air circulation, keep the area around the indicator clear.

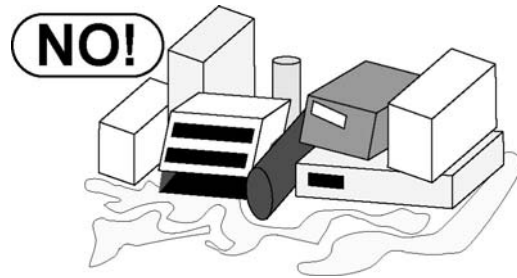

Make certain the indicator is not directly in front of a heating or cooling vent. Such a location will subject the indicator to sudden temperature changes, which may result in unstable weight readings.

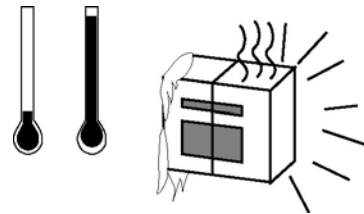

Insure that the indicator has good, clean AC power and is properly grounded. In areas subject to lightning strikes, additional protection to minimize lightning damage, such as surge suppressors, should be installed.

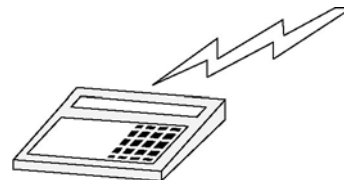

# SITE PREPARATION REQUIREMENTS, CONT.

## Electrical Power

The 225 has been designed to operate from 100 to 240 VAC @ 0.4A Max. at 50/60 Hz. Note that a special order is not required for operation at 230/240 VAC.



**WARNING!** To avoid electrical hazard and possible damage to the indicator, **DO NOT**, under any circumstance, cut, remove, alter, or in any way bypass the power cord grounding prong.

- The socket-outlet supplying power to the indicator should be on a separate circuit from the distribution panel and dedicated to the exclusive use of the indicator.
- The socket-outlet shall be installed near the equipment and shall be easily accessible. Note that the power cord on the 225 serves as the power disconnect.
- The wiring should conform to national and local electrical codes and ordinances and should be approved by the local inspector to assure compliance.
- For outdoor operations, the socket-outlet must provide GFCI (ground fault circuit interrupter) protection
- On installations requiring 230/240 VAC power, **it is the responsibility of the customer** to have a qualified electrician install the proper power cord plug that conforms to national electrical codes and local codes and ordinances.

## Electrical Noise Interference

To prevent electrical noise interference, make certain all other wall outlets for use with air conditioning and heating equipment, lighting or other equipment with heavily inductive loads, such as welders, motors and solenoids are on circuits separate from the indicator. Many of these disturbances originate within the building itself and can seriously affect the operation of the instrument. These sources of disturbances must be identified and steps must be taken to prevent possible adverse effects on the instrument. Examples of available alternatives include isolation transformers, power regulators, uninterruptible power supplies, or simple line filters.

## Transient Suppression

The following recommendations will help to reduce transients:

- Always use shielded cables to connect signal wires to the weight indicator.
- Secure the cables in the cable clips provided inside the indicator.
- Connect the cable shield (indicator end only) to a ground point inside the indicator. Keep wires that extend beyond the shield as short as possible.
- Do not run load cell or signal cables from the weight indicator along side or parallel to wiring carrying AC power. If unavoidable, position the load cell and signal cables a minimum of 24" away from all AC wiring.
- Always use arc suppressors across all AC power relay contacts (see recommendations at [http://www.paktron.com/pdf/Quencharch\\_QRL.pdf](http://www.paktron.com/pdf/Quencharch_QRL.pdf)).
- Use zero voltage switching relays, optically isolated if possible.

# **SITE PREPARATION REQUIREMENTS, CONT.**

## **RFI Immunity**

The operation of sensitive electronic equipment can be adversely affected by RF (Radio Frequency) radio transmissions. Digital weight indicators are one such type of equipment. Radio transmissions come from things like hand-held radio transmitters and cell phones. One symptom of RFI (Radio Frequency Interference) in a digital weight indicator is weight indication instability during a radio transmission.

Cardinal digital weight indicators are designed with special grounding and RFI shielding to achieve a high degree of immunity to common RFI. To maximize the digital weight indicator's immunity to radio transmissions, follow these guidelines:

1. ALWAYS use shielded cable for all I/O (Input/Output) connections to the digital weight indicator.
2. NEVER operate any radio transmitter within 2 meters (~6ft.) of the weight indicator.
3. NEVER connect un-terminated serial, digital, or analog I/O cables to the internal printed circuit boards of the digital weight indicator.
4. KEEP the intended external I/O device connected to I/O cables entering the digital weight indicator.
5. ALWAYS connect the shield of the shielded cable to the indicator back panel gland connector or other closest ground terminal inside the indicator.
6. ALWAYS connect the shield of the shielded I/O cable at the indicator end only. Leave the shield unconnected at the I/O device.





# INSTALLATION

Before beginning installation of your Model 225 Weight Indicator, make certain that it has been received in good condition. Carefully remove it from the shipping carton and inspect it for any evidence of damage (such as exterior dents or scratches) that may have taken place during shipment. Keep the carton and packing material for return shipment if it should become necessary. It is the responsibility of the purchaser to file all claims for any damages or loss incurred during transit.

## Mounting

**NOTE:** Should your 225 indicator come already installed on a scale, the following information describing the installation of the indicator does not apply.

The Model 225 Indicator is housed in a Stainless Steel wall or desk-mount enclosure. The 225 gimbal may be mounted on a desk, table or other smooth, flat, horizontal surface or may be mounted on a wall. Refer to Figure No. 1 for a layout of wall mounting.

**Figure No. 1**

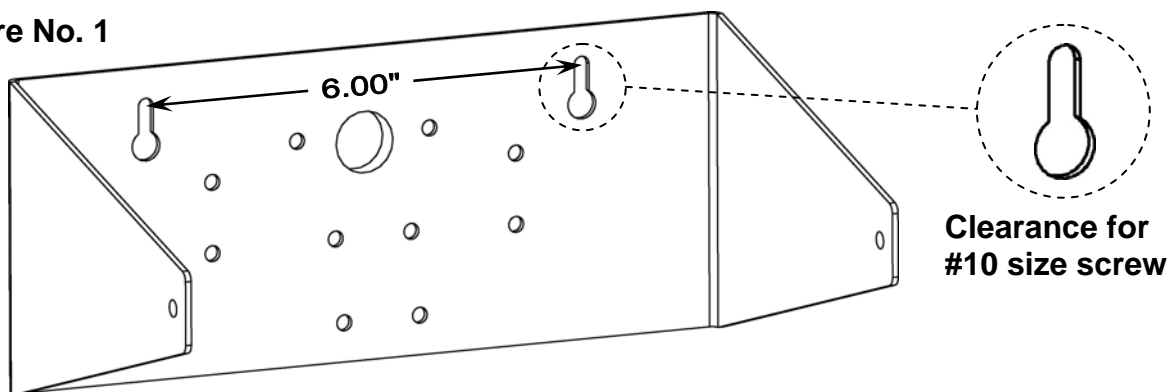

If wall mounted, make certain the mounting surface is strong enough to support the instrument. The mounting location should be where the display is easily viewed while being close enough to provide the operator easy access to the keypad. Carefully lay out the mounting hole locations, then drill and install the anchor bolts. Attach the gimbal to the wall and securely tighten the retaining bolts.

# INSTALLATION, CONT.

## Load Cell Connections



**WARNING!** Disconnect any external load cell power supply before connecting load cells to the indicator. Failure to do so will result in permanent damage to the indicator.

## Load Cell Cable Connection with RFI Suppression

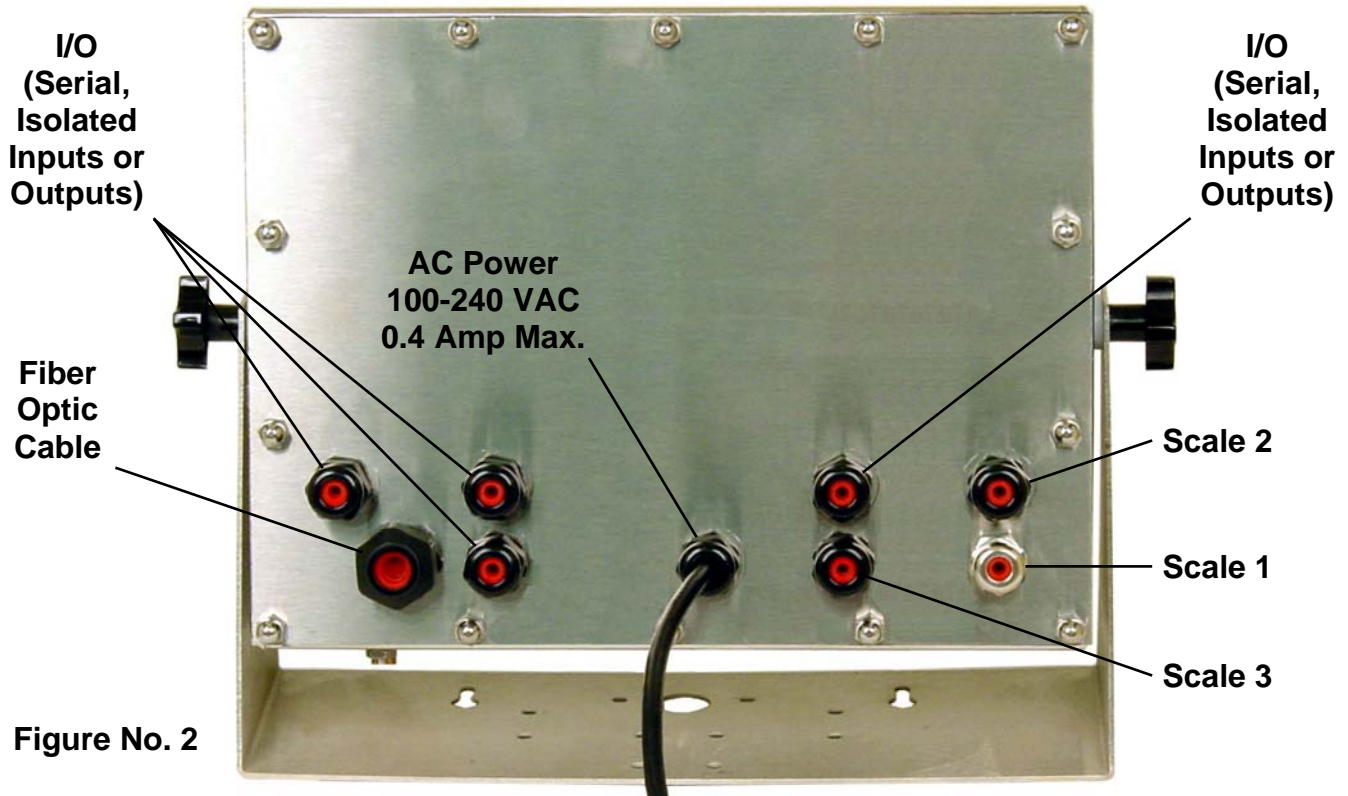

**Figure No. 2**

To eliminate RFI, the load cell cable should be routed through the special metallic gland connector and the shield wire from the load cell cable must be connected to this gland connector for grounding. Refer to Figure No. 2 for the gland connector layout.

1. Remove the 14 acorn nuts securing the rear panel to the main housing.
2. Loosen and remove the metal gland connector nut and remove the plastic insert.
3. Referring to Figure No. 3, route the single cable from the load cell or load cell junction box through the nut and plastic insert and into the enclosure.



**Figure No. 3**

## INSTALLATION, CONT.

4. With the load cell cable routed into the enclosure, refer to Figure No. 4 and then remove approximately 5 to 6 inches of the cable outer insulating jacket exposing the internal wires.
5. Next, cut the shield wire so that it extends past the outer jacket approximately 3/4 inch.
6. Now, remove 1/4 inch of insulation from the end of each of the four wires (without sense leads) or six wires with sense leads.

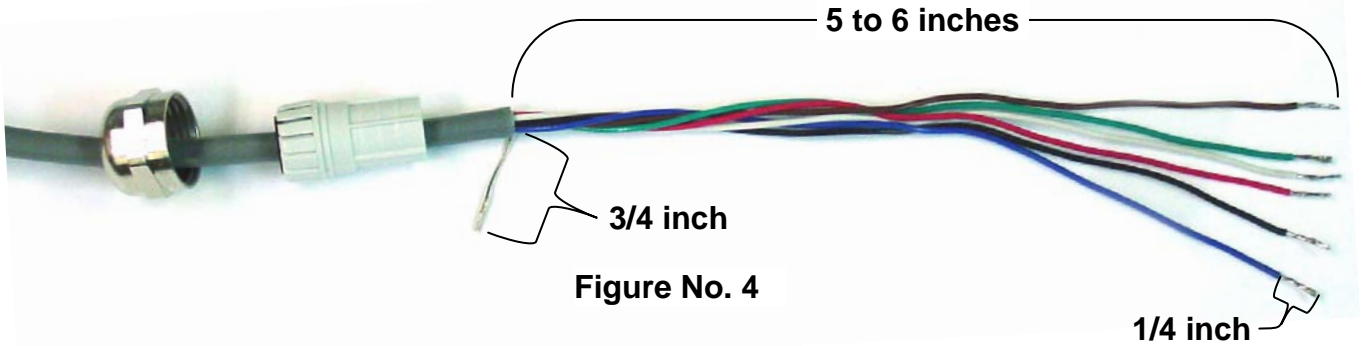

7. Referring to the table below (or on the circuit board) for terminal connections, connect each wire to terminal block P21. Refer to Figure No. 13 for terminal block location.

<b>LOAD CELL CONNECTOR P21</b>			
<b><u>PIN NO.</u></b>	<b><u>Function</u></b>	<b><u>PIN NO.</u></b>	<b><u>Function</u></b>
1	+ EXCITATION	5	- SIGNAL
2	+ SENSE	6	- SENSE
3	+ SIGNAL	7	- EXCITATION

8. To terminate a wire, use a small flat blade screwdriver and press down on the release bar for the terminal. Insert the wire into the opening and remove the screwdriver, allowing the release bar to return to its original position, locking the wire in place. See Figure No. 5.

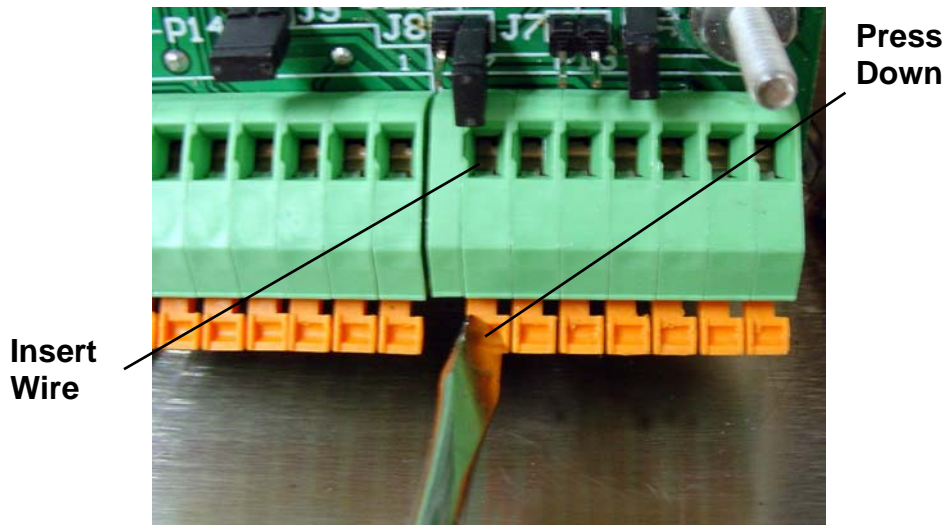

## INSTALLATION, CONT.

9. Repeat the procedure until all wires are in place.
10. After all terminations have been made, remove the excess cable from the enclosure.
11. Referring to Figure No. 6, fold the shield wire back over the plastic insert and then insert the plastic insert (with the shield wire) into the gland connector.

**Figure No. 6**



**Shield  
Wire**

12. The shield wire is secured when tightening the gland connector nut. See Figure No. 7.



**Figure No. 7**

13. Do not over-tighten the connector but make certain it is snug.

# INSTALLATION, CONT.

## Load Cell Cable Connection without RFI Suppression

The following instructions describe the load cell connection without RFI Suppression should it not be required.

1. Remove the 14 acorn nuts securing the rear panel to the main housing.
2. Referring to Figure No. 2, choose a gland connector for the load cell cable and loosen it.
3. Slip the single cable from the load cell or load cell junction box through the gland connector and into the enclosure.
4. Referring to Figure No. 4, remove 3 inches (not 5 to 6 inches) of the outer insulation jacket
5. Next, remove 1/4 inch of insulation from each of the four wires and shield (without sense leads) or six wires and shield (with sense leads).
6. Referring to the table below (or on the circuit board) for terminal connections, connect each of the wires to terminal block P21. Refer to Figure No. 13 for terminal block location.

LOAD CELL TERMINAL – (P21)			
<u>PIN NO.</u>	<u>Function</u>	<u>PIN NO.</u>	<u>Function</u>
1	+ EXCITATION	5	- SIGNAL
2	+ SENSE	6	- SENSE
3	+ SIGNAL	7	- EXCITATION
4	SHIELD		

7. To terminate a wire, use a small flat blade screwdriver and press down on the release bar for the terminal. Insert the wire into the terminal opening. Remove the screwdriver, allowing the release bar to return to its original position, locking the wire in place. See Figure No. 5.
8. Repeat the procedure until all wires are in place.
9. The load cell cable shield wire should be connected to terminal 4 on terminal block P21.

## Load Cell Connections with Over 30 Feet of Cable

For installations with over 30 feet of cable between the indicator and the load cells, sense wires should be used. The sense wires must be connected between the +SENS, -SENS terminals on the indicator and the +EXCITATION, -EXCITATION wires of the load cells or the +SENS, -SENS terminals of the load cell trim board or the section seal trim board. For the indicator to use the sense wires, the +SENS jumper J7 and the -SENS jumper J9 must be open (see Figure No. 13).

# INSTALLATION, CONT.

## Serial I/O Cable Installation

The 225 may be connected to a printer to record weight and associated data or it may be connected to a remote display or even to a computer for transmission of weight data. The weight data may be transmitted on demand (pressing the **PRINT** key or on receipt of a command from the computer).

1. If the rear panel of the indicator has been removed, proceed to step 2. Otherwise, remove the 14 acorn nuts securing the rear panel to main housing
2. Loosen the gland connector for the serial cable. Refer to Figure No. 2 for the gland connector layout.
3. Slip the serial cable through the gland connector and into the enclosure.
4. Referring to Figure No. 4, remove 2 inches (not 5 to 6 inches) of the outer insulation jacket
5. Next, remove 1/4 inch of insulation from each of the wires.
6. Connect each of the wires to the Serial I/O terminal block (P16) referring to Figure No. 13 for terminal block locations.
7. To terminate a wire, use a small flat blade screwdriver and press down on the release bar for the terminal. Insert the wire into the terminal opening. Remove the screwdriver, allowing the release bar to return to its original position, locking the wire in place. See Figure No. 5.
8. Repeat procedure until all of wires are in place.

<b>COM0/COM1 – TERMINAL (P20)</b>	
<b><u>PIN NO.</u></b>	<b><u>Function</u></b>
<b>1</b>	TxD0-RS232
<b>2</b>	GND
<b>3</b>	TxD1-SRC
<b>4</b>	TxD1-20mA+
<b>5</b>	TxD1-20mA-
<b>6</b>	RxD1-RS232
<b>7</b>	TxD1-RS232
<b>8</b>	GND
<b>9</b>	RxD0-RS232
<b>10</b>	TxD0-20mA active

<b>COM2/COM3 – TERMINAL (P16)</b>	
<b><u>PIN NO.</u></b>	<b><u>Function</u></b>
<b>1</b>	TxD0 +20mA SRC
<b>2</b>	TxD2-20mA+
<b>3</b>	TxD2-20mA-
<b>4</b>	+20mA SRC
<b>5</b>	RxD2-20mA+
<b>6</b>	RxD2-20mA-
<b>7</b>	RxD2-RS232
<b>8</b>	TxD2-RS232
<b>9</b>	GND2
<b>10</b>	RxD3-RS232
<b>11</b>	TxD3-RS232
<b>12</b>	GND
<b>13</b>	CTS

- \* When connecting a serial printer (using the Cardinal serial data cable, 8539-B108-1A) only two wires are used. The RED wire should be connected to Pin 1 (TxD0-RS232) and the BLACK wire to Pin 2 (GND).

## INSTALLATION, CONT.

### Serial Ports Specifications (Continuous or On-Demand Output\*)

- BAUD RATES ..... 300 to 230.4K BAUD (each port individually selectable).
1. COM0 (TxD0)... RS-232 BI-DIRECTIONAL USE TO 100' AND 20mA  
CURRENT LOOP (active/passive) OUTPUT USE TO 1000'
  2. COM1 (TxD1) ..... RS-232 BI-DIRECTIONAL USE TO 100' AND 20mA  
CURRENT LOOP (active/passive) OUTPUT USE TO 1000'
  3. COM2 (TxD2) ..... RS-232 BI-DIRECTIONAL USE TO 100' AND 20mA  
CURRENT LOOP (active/passive) BI-DIRECTIONAL USE  
TO 1000'
  4. COM3 (TxD3) ..... RS-232 BI-DIRECTIONAL USE TO 100' AND 20mA  
CURRENT LOOP (active) OUTPUT USE TO 1000'
  4. COM3 (USB) ..... STANDARD FULL SPEED (12Mbps) USB 2.0 DEVICE  
PORT. USE WITH CARDINAL SCALE 8200-B163-0A USB  
CABLE OR A INDUSTRY STANDARD USB 2.0 CABLE

#### \*Continuous Output Rate = Weight Sample Rate

**NOTE:** The Max. output rate is limited by the selected baud rate.

Example:                   Max output rate = 50 samples/sec at ≤ 9600 baud  
                                   Max output rate = 100 samples/sec at ≥ 19.2k baud

PORT	RS-232 OUTPUT	RS-232 INPUT	20mA ACTIVE OUTPUT	20mA PASSIVE OUTPUT	20mA ACT/PASS INPUT	USB
<b>MAXIMUM DISTANCE</b>	100'	100'	1,000'	1,000'	1,000'	
<b>COM0</b>	X					
<b>COM1</b>	X	X	X	X		
<b>COM2</b>	X	X	X	X	X	
<b>COM3</b>	X	X	X			*X

1. SETUP MENU #2, SERIAL, PORT, SCALE=1, 2, 3, 4 (TOTAL), CONT=YES outputs continuous weight of the designated scale out the designated port.
2. SETUP MENU #2, SERIAL, PORT, SCALE=1, 2, 3, 4 (TOTAL), CONT=NO outputs weight-on-demand of the designated scale out the designated port.
3. SETUP MENU #2, SERIAL, PORT, SCALE=0, CONT=YES outputs continuous weight of the selected (active) scale out the designated port for multi-scale operation.

\* Mutually exclusive

## INSTALLATION, CONT.

### Print Key Serial Port Selection

**NOTE:** The serial port used for the **PRINT** key is selected in the **PRINT TABS** menu,

PORT= 0 (COM0)

PORT= 1 (COM1)

PORT= 2 (COM2)

PORT= 3 (COM3/USB)

**NOTE:** Multi-scale printing prints the selected (active) scale out the selected port.



# INSTALLATION, CONT.

## USB Interface

The 225 indicator USB Interface is a standard full speed (12Mbps) USB 2.0 device port. It can be connected to a USB 2.0 host, with the Cardinal Scale 8200-B163-0A USB CABLE or a industry standard USB 2.0 cable, to be used as the COM3 serial I/O port set to 8 bit data, 1 stop bit, no parity, 9600 to 115.2k baud. Refer to the SETUP MENU #2, SERIAL INPUT/OUTPUT SETUP section of this manual.

The USB port is enabled with jumpers J3 and J4 (see Figure No. 15) set to the USB position (utilizing the indicator COM3 serial port) and the USB PWR jumper, J10 (see Figure No. 15), set to the BUS position to be powered by the USB host or to the VCC position to be powered by the 225 indicator main PC board. Follow the “Driver Installation Instructions for Indicator’s USB Port” in conjunction with the usb2ser.inf file located on the 225 Indicator Installation and Technical Manual CD.

## 8200-B163-0A Water Tight USB Cable Installation

1. Remove the 14 acorn nuts securing the back panel to main housing.
2. Remove a gland connector from the back panel. Refer to Figure No. 2 for illustration of connector layout.
3. Loosen the gland connector nut from the 8200-B163-0A cable/gland assembly (see Figure No. 8) and slip off over the 5-pin cable connector and ground wire.
4. Insert the 5-pin connector and ground wire through the rear panel.
5. Slip the gland connector nut back over the 5-pin connector and ground wire and tighten on the gland connector on the rear panel.
6. Pull the USB cable through the gland to reach P4, the USB-B header.
7. Plug the USB cable connector onto the USB-B, P4 header, referring to Figure No. 15 for the location of P4. Tighten the gland cable nut on the USB cable.

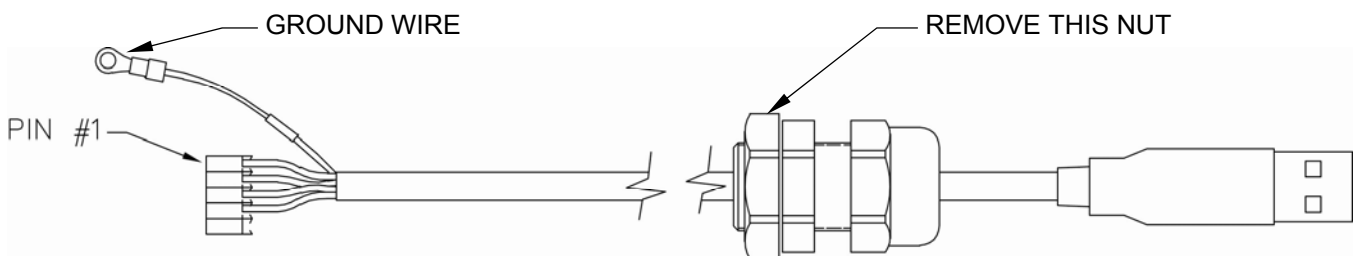

Figure No. 8

8. To attach the ground wire (see Figure No. 8), remove a 6-32 nut and washer from the corner of the main board.
9. Connect the ground wire from the USB cable by placing the ring terminal over the 6-32 threaded stud.
10. Reinstall the washer and 6-32 nut and tighten.

## **INSTALLATION, CONT.**

### **Standard USB Cable Installation**

1. Remove the 14 acorn nuts securing the back panel to main housing.
2. Remove a gland connector from the back panel. Refer to Figure No. 2 for illustration of connector layout.
3. Slip the cable through the hole in the rear panel and into the enclosure.
4. Plug the USB cable into the USB-B connector P6. See Figure No. 15 for the location of P6.

# INSTALLATION, CONT.

## I/O Ports Interconnections

### Interconnect Wiring for COM0/COM1 20mA Current Loop Operation

Peripheral Device has **ACTIVE END** of Current Loop.

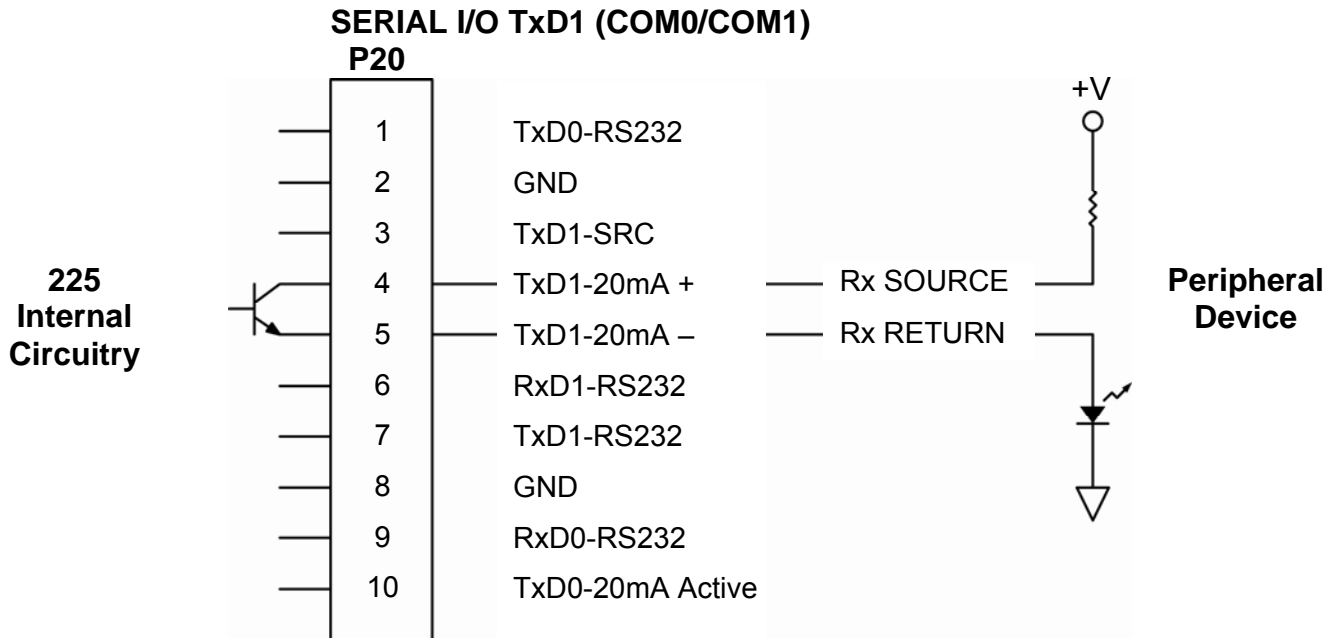

### Interconnect Wiring for COM0/COM1 20mA Current Loop Operation

Peripheral Device has **PASSIVE END** of Current Loop.

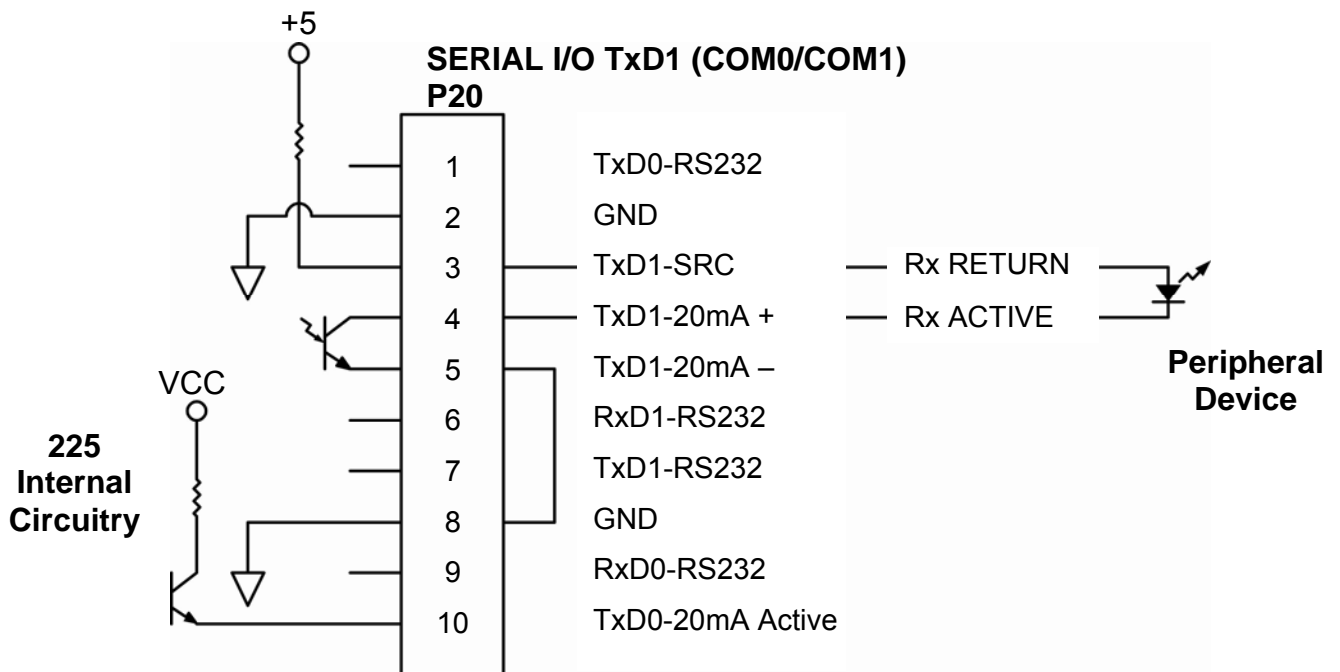

# INSTALLATION, CONT.

**Interconnect Wiring for COM2/COM3 20mA Current Loop Operation**  
Peripheral Device has **ACTIVE END** of Current Loop.

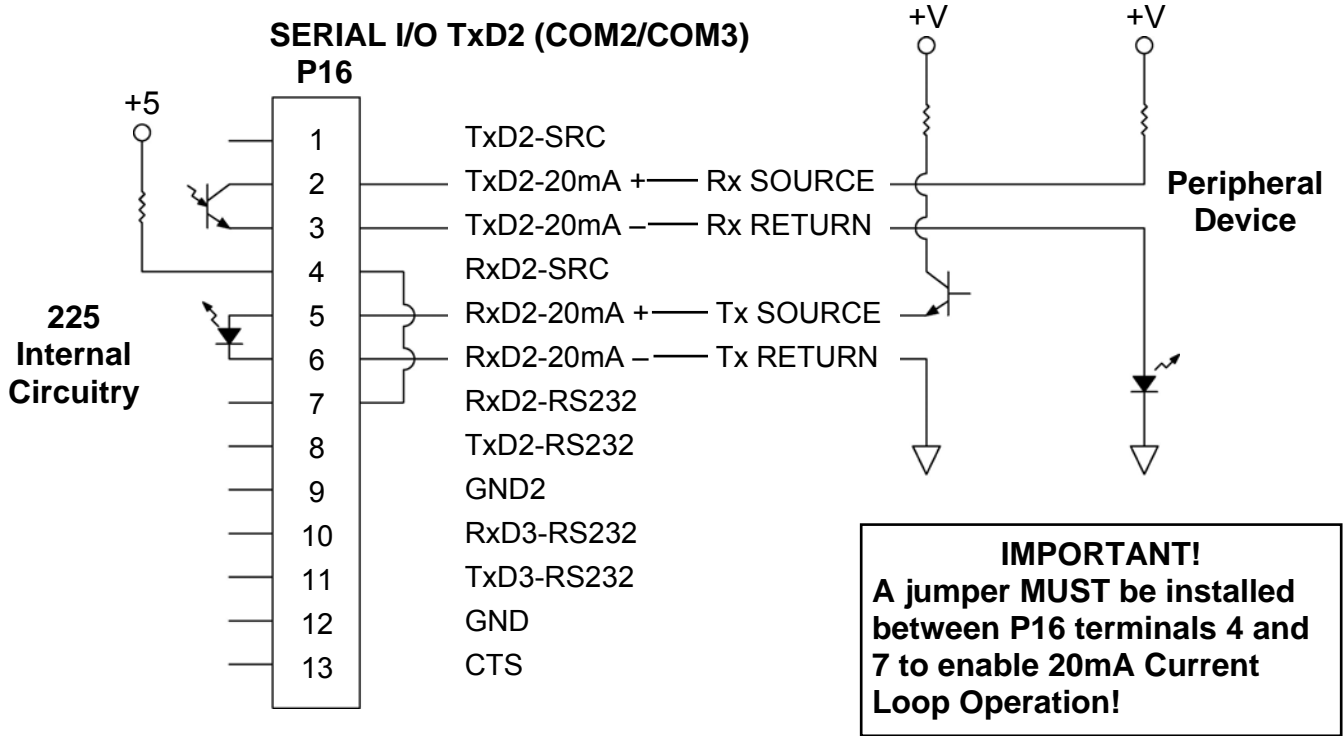

**Interconnect Wiring for COM2/COM3 20mA Current Loop Operation**  
Peripheral Device has **PASSIVE END** of Current Loop.

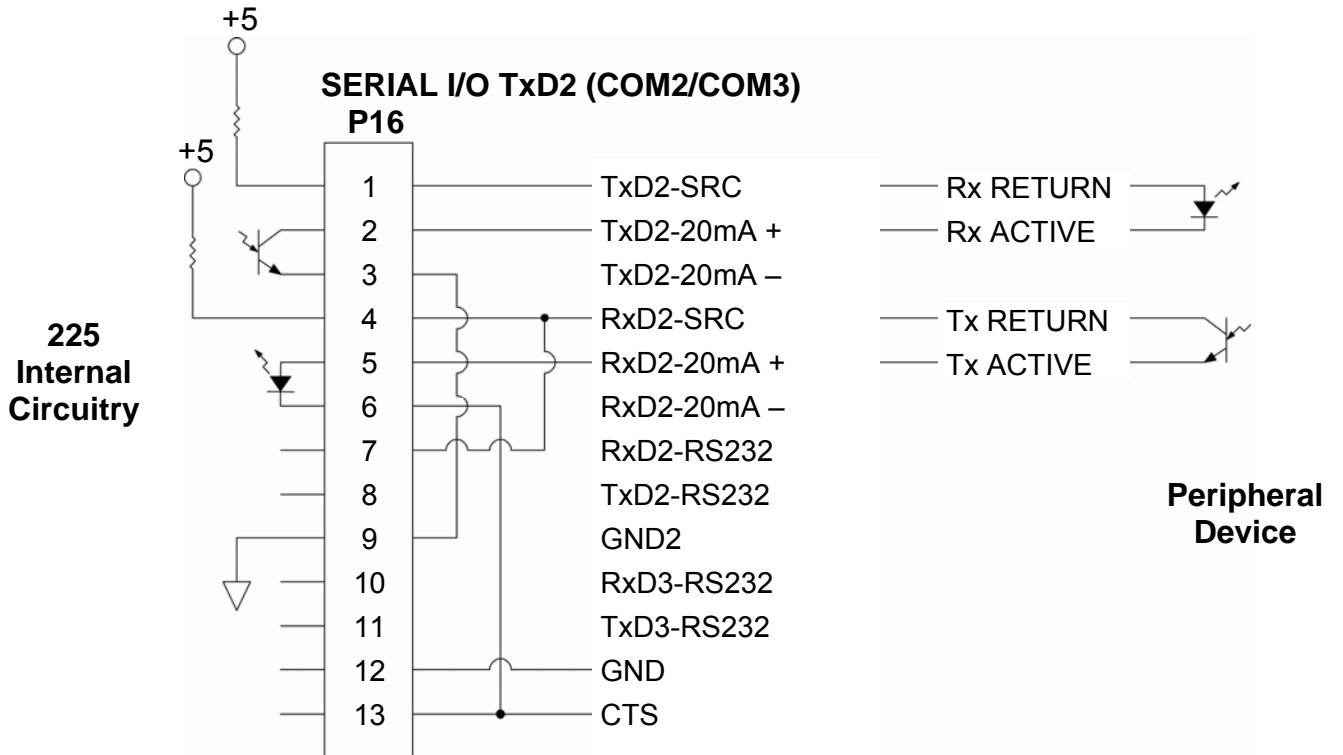

## INSTALLATION, CONT.

### Optically Isolated Remote Inputs

Included with the I/O are 7 programmable inputs that may be used to remotely (up to 100 feet) initiate various functions within the indicator. These inputs are accessed via a terminal block (P17) on the back of the PC board (see Figure No. 13). The 7 inputs are defined as follows:

<b>REMOTE INPUTS TERMINAL – (P17)</b>				
<b><u>PIN NO.</u></b>	<b><u>Function</u></b>		<b><u>PIN NO.</u></b>	<b><u>Function</u></b>
1	+ SRC(12 to 24VDC)		6	*
2	ZERO		7	STOP
3	TARE		8	START
4	G/N (Gross/Net)		9	DUMP
5	PRINT		10	GND/SHIELD

**Remember that the input must be connected to GND to initiate the function.**

### AC Input Relay Board(s)

The AC Input Relay Board(s) are mounted in an external junction box for use with the 225 Indicator. The RB4-ACIN (115 VAC) or RB4-ACINV (230 VAC) contain one board and supports 4 inputs (jumper selectable). The RB8-ACIN (115 VAC) or RB8-ACINV (230 VAC) contain two boards and supports seven inputs that are jumper selectable. The relay board used in the 115 VAC versions is Cardinal p/n 8200-C324-0A. The 230 VAC version uses relay board Cardinal p/n 8200-C324-1A. Connect the devices as shown in Figure No. 8.

INPUT RELAY TYPE IAC-5	90 to 140 VAC @ 6mA maximum for each plug-in relay
INPUT RELAY TYPE IAC-5A	180 to 280 VAC @ 6mA maximum for each plug-in relay
OUTPUT	5VDC @ 12mA from the 225 main pc board assembly P9 12VDC @ 12mA maximum from external source
CONNECTION	Removable plug-in screw terminals for up to 14 AWG wire

# INSTALLATION, CONT.

## AC Input Relay Board(s), Cont.

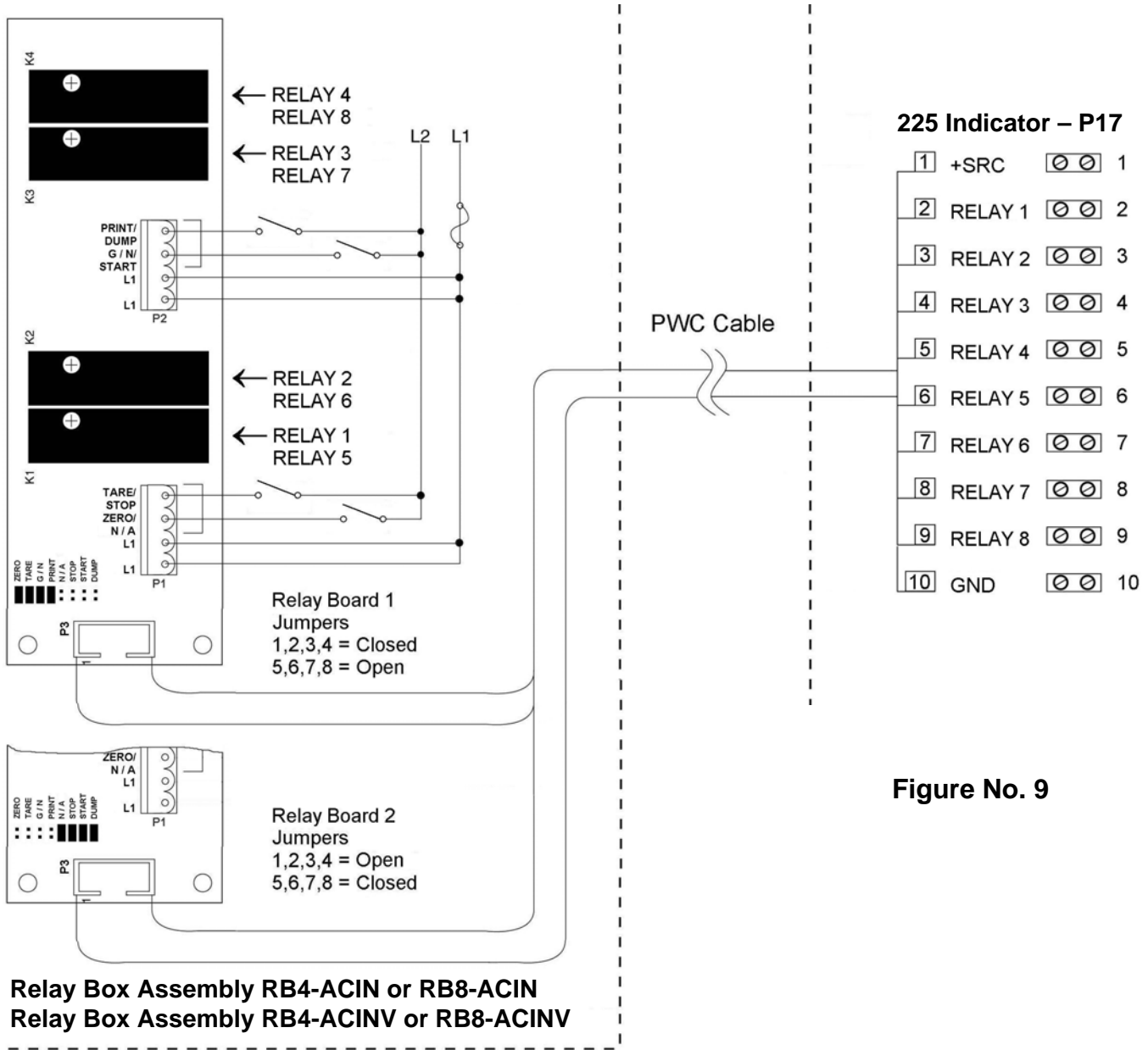

Figure No. 9



**NOTE: AC INPUT RELAYS ARE VOLTAGE DEPENDENT. A DIFFERENT RELAY IS REQUIRED FOR 115 VAC AND 230 VAC!**

## INSTALLATION, CONT.

### Preset Weight Comparator/Checkweigher Logic Level Output

If you so choose, you may use the logic level outputs from your Model 225 indicator's preset weight comparators or checkweigher to control peripheral devices used to manage the flow of material or signal when the weight is within preset limits. Note that these outputs are at logic level and cannot drive external devices directly, with the exception of the Cardinal 2XX-OU CHECK WEIGHER LIGHT BAR. Solid-state relays can be used to accept the logic level output from the 225 and in turn, drive other external devices.

1. If the rear panel of the indicator has been removed, proceed to step 2. Otherwise, remove the 14 acorn nuts securing the rear panel to main housing
2. Loosen the gland connector for the cable. Refer to Figure No. 2 for the gland connector layout.
3. Slip the cable through the gland connector and into the enclosure.
4. Referring to Figure No. 4, remove 2 inches (not 5 to 6 inches) of the outer insulation jacket
5. Next, remove 1/4 inch of insulation from each of the wires.
6. Connect each of the wires to the Remote Outputs terminal block (P19 or P18) referring to Figure No. 13 for terminal block locations.
7. To terminate a wire, use a small flat blade screwdriver and press down on the release bar for the terminal. Insert the wire into the terminal opening. Remove the screwdriver, allowing the release bar to return to its original position, locking the wire in place. See Figure No. 5.
8. Repeat procedure until all wires are in place.

### AC Output Relay Board(s)

The AC Output Relay Boards are mounted in an external junction box for use with the 225 Indicator and can be purchased from Cardinal. The RB4-ACOUT contains one board and supports four outputs (jumper selectable). The RB8-ACOUT contains two boards and supports eight outputs. The relay board used in both is (Cardinal p/n 8539-C062-0A). Connect the devices to be controlled as shown in Figure No. 9 and 10.

The individual relays can be configured to be on (closed) or off (open) at weights under the preset weight then switch at the preset weight from on-to-off or off-to-on by setting the under weight condition to on or off during setup and calibration or setup review.

OUTPUT (closed)	28-240VAC @ 3A maximum for each plug-in relay
CONTROL INPUT	5VDC @ 12mA from the 225 main pc board assembly P8
CONNECTION	Removable plug-in screw terminals for up to 14 AWG wire

**NOTE:** All relays are the normally open type that will open when power to indicator is lost.

# INSTALLATION, CONT.

## AC Output Relay Board(s), Cont.

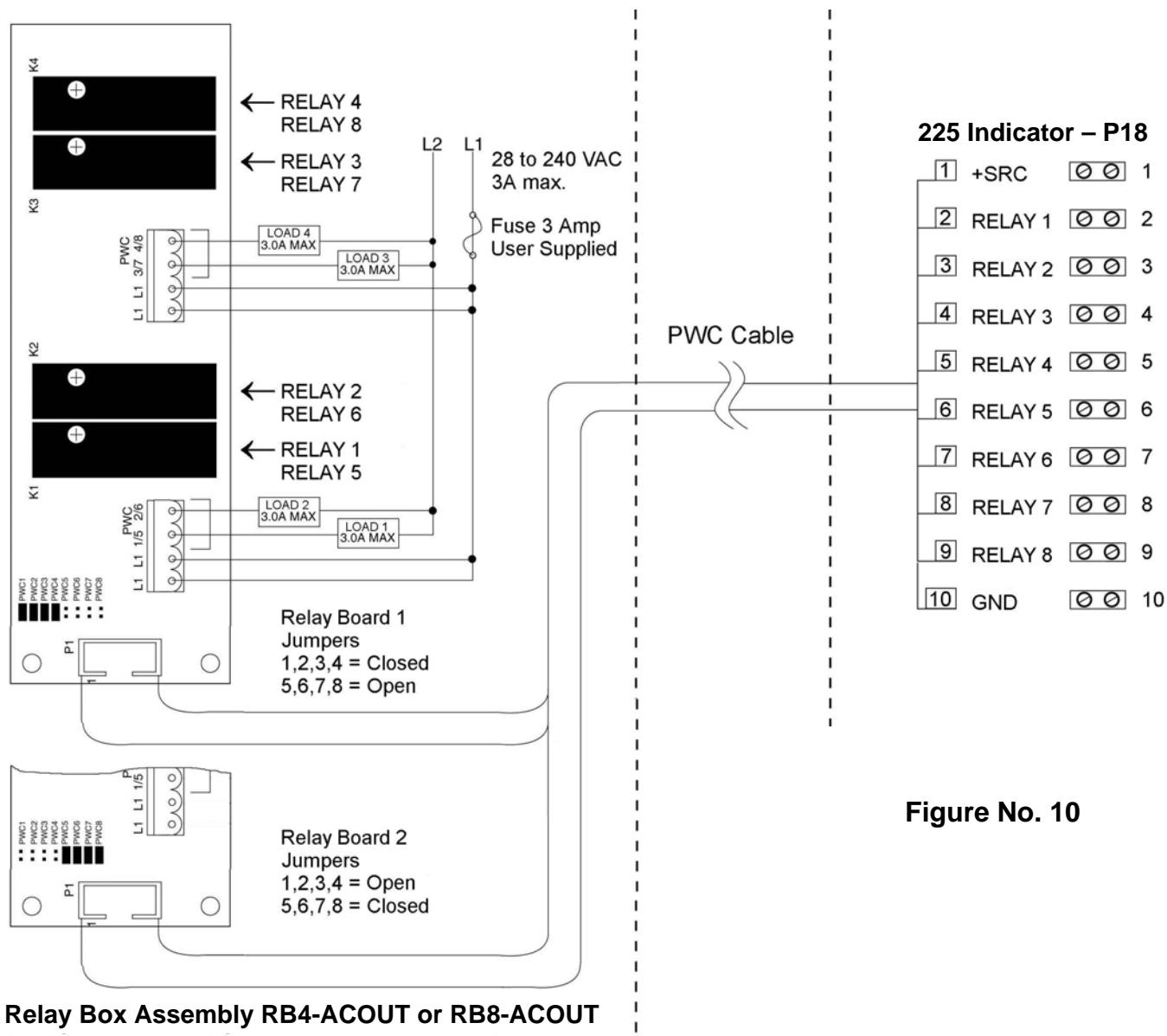

Figure No. 10



# INSTALLATION, CONT.

## AC Output Relay Board(s), Cont.

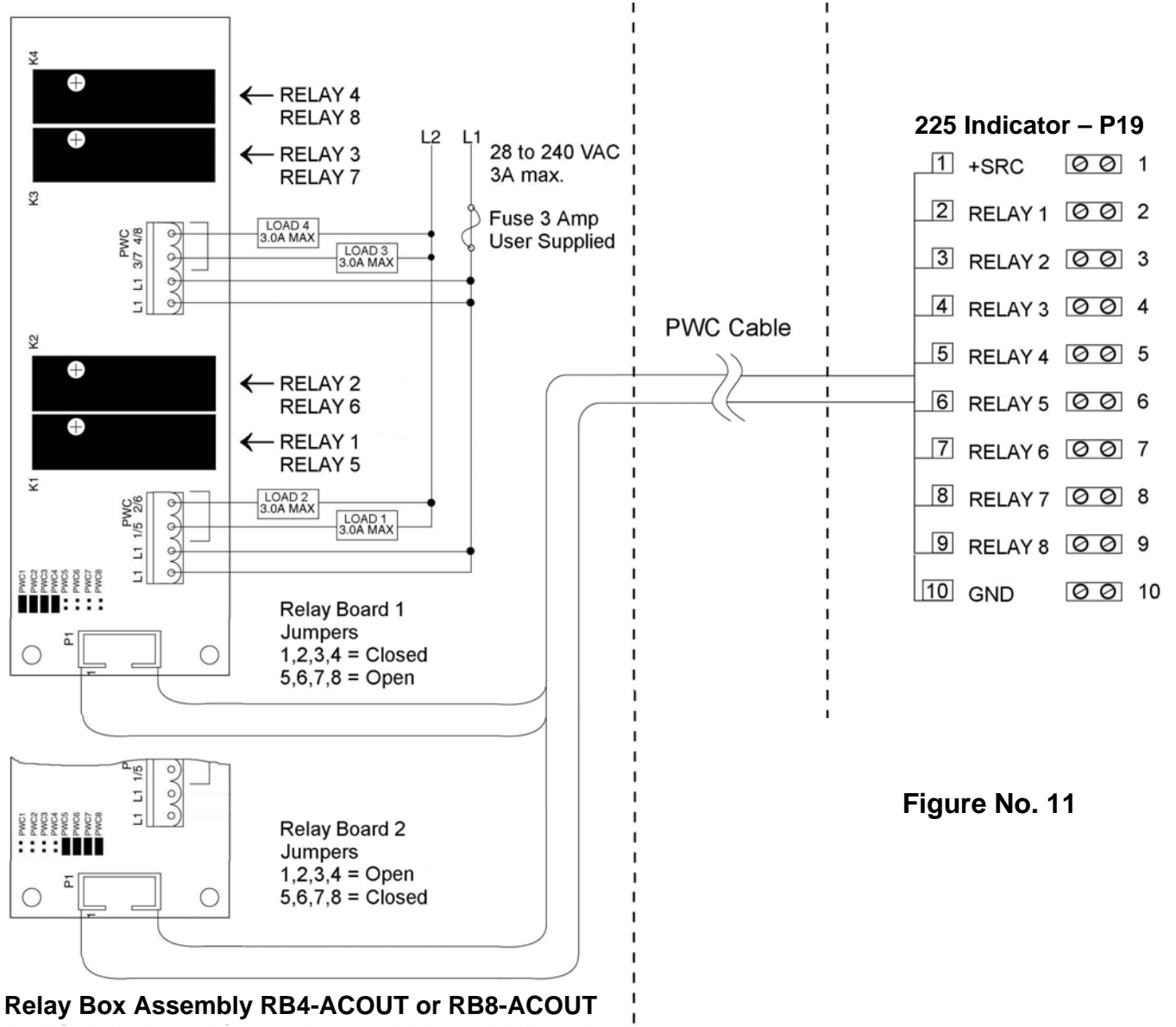

Figure No. 11

## INSTALLATION, CONT.

### DC Output Relay Board(s)

The DC Output Relay Boards are mounted in an external junction box for use with the 225 Indicator and can be purchased from Cardinal. The RB4-DCOUT contains one board and supports four outputs (jumper selectable). The RB8-DCOUT contains two boards and supports eight outputs. The relay board used in all boxes is (Cardinal p/n 8539-C062-1A). Connect the devices to be controlled as shown in Figures No. 11 and 12.

The individual relays can be configured to be on (closed) or off (open) at weights under the preset weight then switch at the preset weight from on-to-off or off-to-on by setting the under weight condition to on or off during setup and calibration in the DIO SETUP MENU.

OUTPUT (closed)	3 to 60VDC @ 3A maximum for each plug-in relay
CONTROL INPUT	5VDC @ 12mA from the 225 main pc board assembly P8
CONNECTION	Removable plug-in screw terminals for up to 14 AWG wire

**NOTE:** All relays are the normally open type that will open when power to indicator is lost.

# INSTALLATION, CONT.

## DC Output Relay Board(s), Cont.

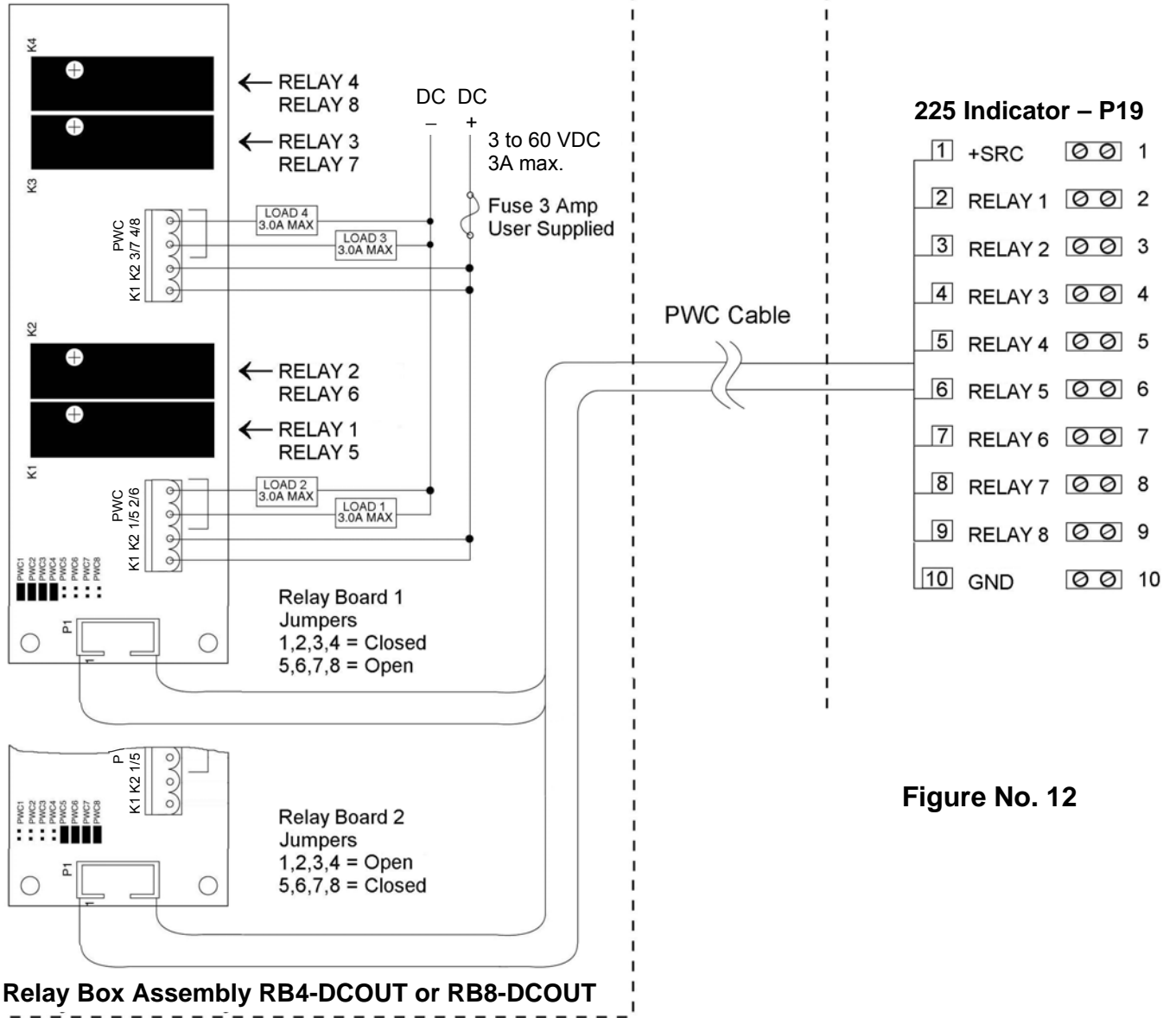

Figure No. 12

# INSTALLATION, CONT.

## DC Output Relay Board(s), Cont.

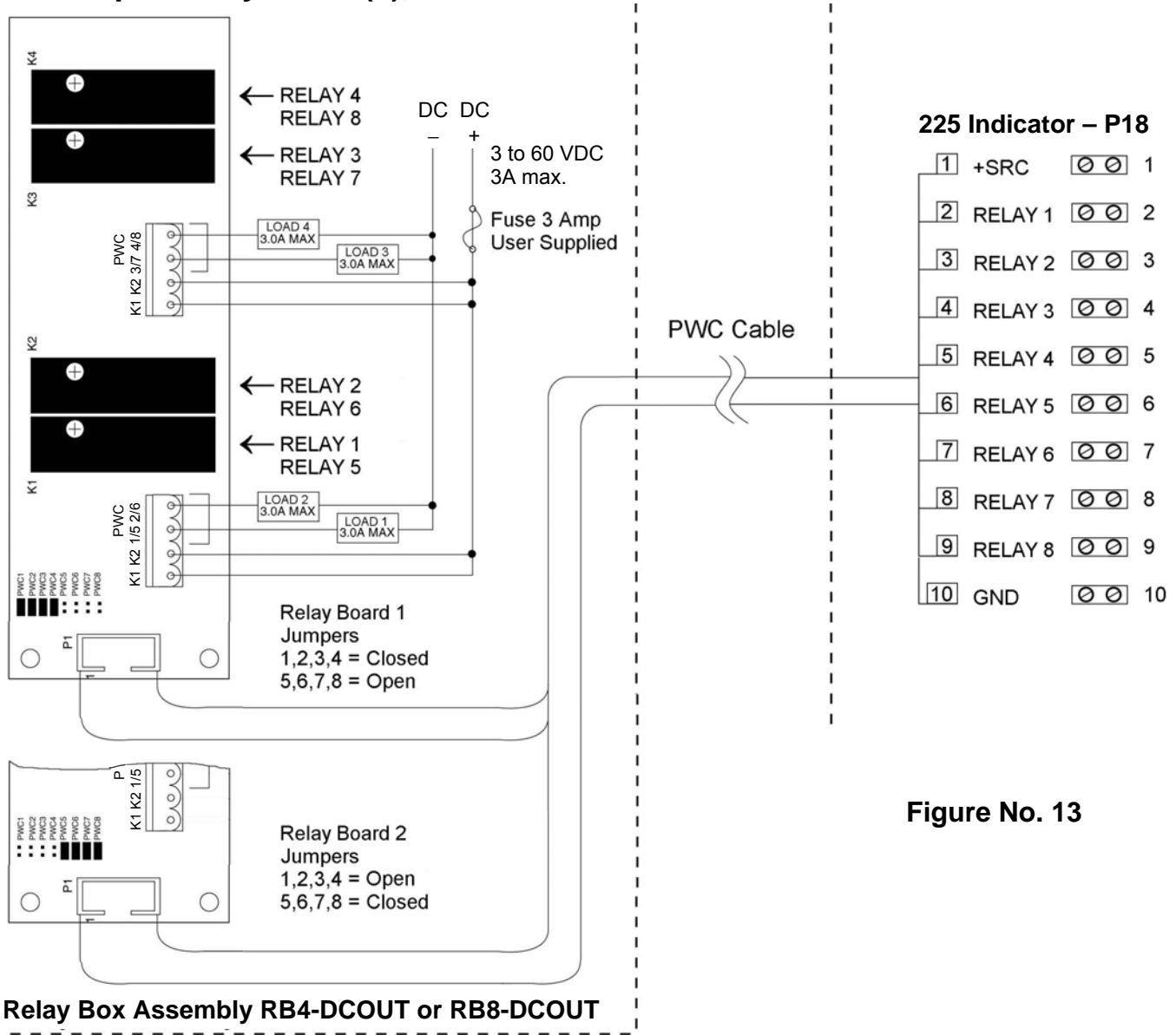
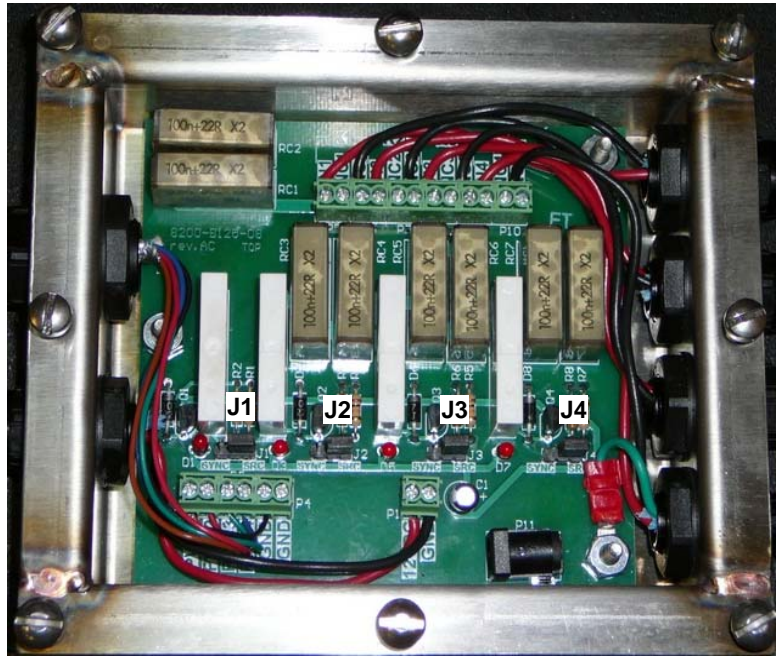

Figure No. 13

# INSTALLATION, CONT.

## RB4C Relay J-BOX

The RB4C provides four FORM-C, SPDT (one normally open and one normally closed), 24-250 volt (AC or DC), 3A mechanical relays to control external devices from a digital weight indicator equipped with output control. The output control can be 5-15VDC, 1mA source or 20mA current sink. The source (SRC) or sink (SINK) type is selected with the Relay Control Source Type Jumpers, J1, J2, J3, and J4 (see Figure No. 14), one for each relay.



**Figure No. 14**  
(Relay Control Source Type Jumpers)

## RB4C Control Circuit Wiring Example

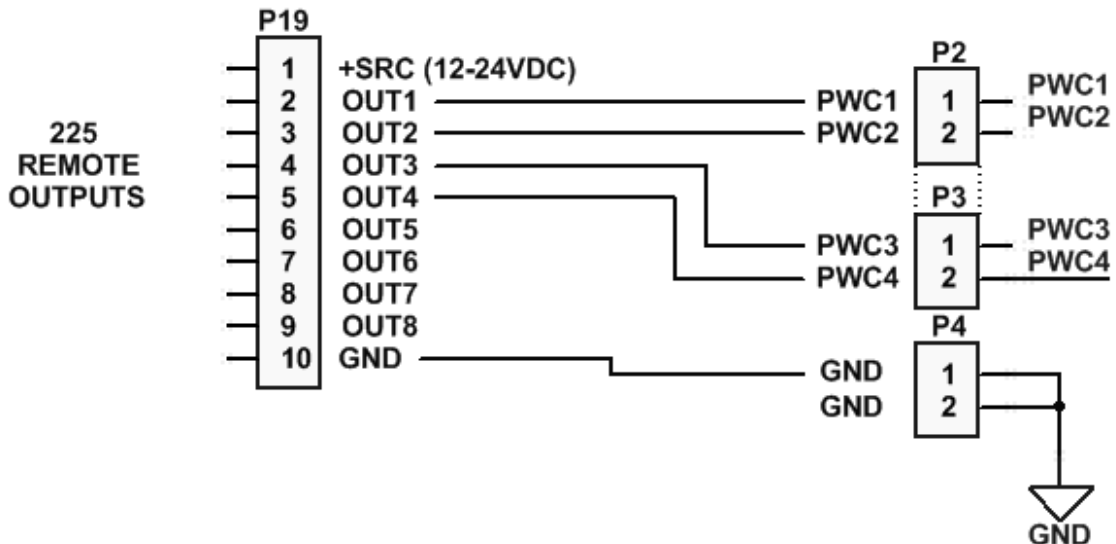

## INSTALLATION, CONT.

### Main PC Board I/O Functions Table

Refer to Figure No. 8 for the AC Input Relay board, Figure No. 9 and Figure No. 10 for the AC Output Relay boards, Figure No. 11 and Figure No. 12 for the DC Output Relay boards and Figure No. 13 for the Main PCB.

INPUTS		OUTPUTS							
		PWC		CHECKWEIGHER		DFC		BATCHER	
P17	INPUTS	P19	Presets	Check 3	Check 5	1 Speed	2 Speed	Batch 1	Batch 2
2	ZERO	2	PWC 1	Under	Under	Fill	Fast	Fill 1	Fast 1
3	TARE	3	PWC 2	Accept	Lo Under		Slow	Fill 2	Slow 1
4	Gross/Net	4	PWC 3	Over	Accept			Fill 3	Fast 2
5	PRINT	5	PWC 4		Lo Over			Fill 4	Slow 2
6	PAUSE	6	PWC 5		Over			Fill 5	Fast 3
7	STOP	7	PWC 6					Fill 6	Slow 3
8	START	8	PWC 7					Fill 7	Fast 4
9	DUMP	9	PWC 8					Fill 8	Slow 4

P18	Presets	Check 3	Check 5	1 Speed	2 Speed	Batch 1	Batch 2
2	PWC 9					Fill 9	Fast 5
3	PWC 10					Fill 10	Slow 5
4	PWC 11					Fill 11	Fast 6
5	PWC 12					Fill 12	Slow 6
6	PWC 13					Fill 13	Fast 7
7	PWC 14					Fill 14	Slow 7
8	PWC 15					Fill 15	
9	PWC 16			Dump	Dump	Dump	Dump

### Relay Box Cable Wire Number to Relay Number Table

The relay box cable wire numbers correspond to the indicator main PC board remote input (P17) and output (P19 and P18) terminal connection pins.

CABLE WIRE NUMBER	RELAY NUMBER (Set Proper Jumpers)	CABLE WIRE NUMBER	RELAY NUMBER (Set Proper Jumpers)
1	+SRC (For AC Input Relays)	6	5
2	1	7	6
3	2	8	7
4	3	9	8
5	4	10	GND



# MAIN PCB



**CAUTION!** This board contains static sensitive components. Improper handling can result in damage to or destruction of the components or board. Such actual and/or consequential damage IS NOT covered under warranty.

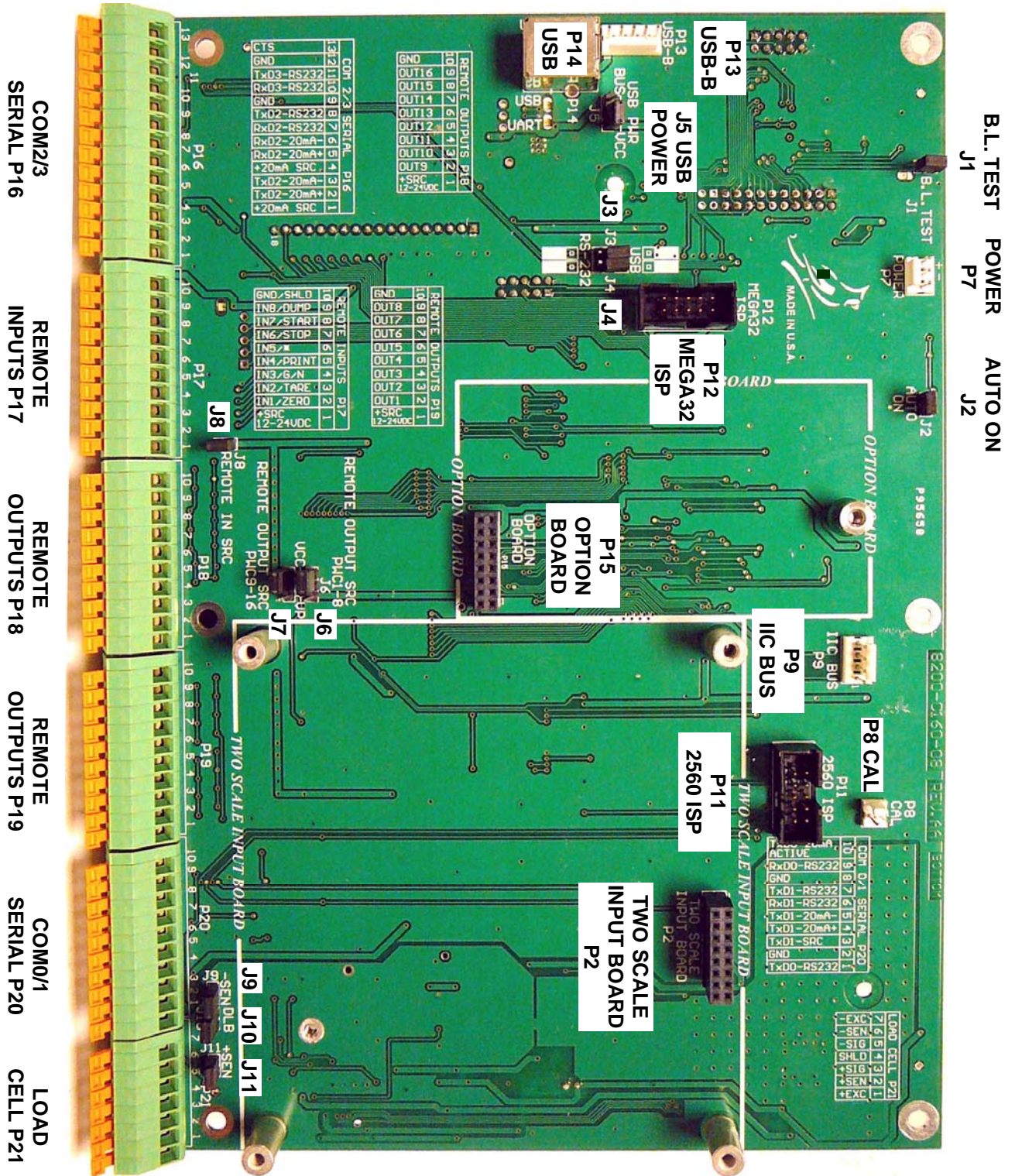

Figure No. 15

# MAIN PC BOARD, CONT.

## Main PCB Jumpers

### J1 (TEST) – B.L. TEST

When installed, this jumper will turn the backlight on, ignoring the `BACK LITE=` setting.

### J2 (AUTO ON) – AUTO-ON

When installed, this jumper will cause the indicator to power on automatically whenever power is applied to the power input connector. If power is lost momentarily and then reapplied, the indicator will turn on without pressing the **ON** key.

### J3 AND J4 – RS-232/USB PORT

These jumpers control whether COM3 is RS-232 and uses Serial I/O P16 (pins 10, 11, and 12) or USB and uses the USB-B header, P13 or USB-B port, P14.

### J6 (PWC1-8) and J7 (PWC9-16) – REMOTE OUTPUT SRC (SOURCE)

When installed, these jumpers allow the 225 indicator to supply (source) 5 VDC (VCC) or 15VDC (VP) to a solid-state relay or other load of 200 ohms or greater. To operate from the 5 VDC (VCC) or 15VDC (VP) source, the positive connection from the relays must be connected to P18 (P19) pins 2 through 9 and the negative wire from the relays to P18 (P19) pin 10 (GND). See Figure No. 10 for connector P18 location and Figure No. 11 for connector P19 location.

For completely isolated outputs, J6 (J7) must be open (on one pin only or removed) and the user must provide 5 to 24 VDC to P18 (P19) pin 1 (+SRC) and a ground return to the load. The load must still be 200 ohms or greater and P18 (P19) pin 10 (GND) is not connected.

### J8 (REMOTE IN) – REMOTE IN SRC (SOURCE)

When installed, this jumper allows the 225 indicator to supply (source) 5 VDC to a remote input circuit. Connecting P17 pins 1 through 9 to P17 pin 10 (GND) through a switch will cause the selected action. See Figure No. 9 for connector P17 location.

For completely isolated inputs, J8 must be open (on one pin only or removed) and the user must provide 5 to 24 VDC to P17 pin 1 (+SRC) and a ground return to the switch connected to P17 pin 2 through 9. Note that P17 pin 10 (GND) is not connected.

### J9 (-SEN) and J11 (+SEN) – SENSE JUMPERS

If the sense leads are NOT used, you must install jumpers at J9 and J11 (near the P20 and P21 terminal blocks). These jumpers connect the sense leads to the excitation leads. If sense leads ARE used (as in motor truck scales), these jumpers should be open (on one pin only or removed).

### J10 (DLB) – DEAD LOAD BOOST JUMPER

For very low dead loads (less than 10% of the combined load cell capacity), connect J8, the DLB (dead load boost) jumper on the printed circuit board.



## MAIN PC BOARD, CONT.

### P8 (CAL) – CALIBRATION INHIBIT JUMPER

When installed, this jumper inhibits (prevents) calibration of the 225 indicator.

When removed, CAL will be shown on the display (to indicate calibration is allowed) and calibration of the 225 indicator can be performed.

## RE-INSTALLING THE REAR PANEL

After all terminations have been made,

1. Remove the excess cable from the instrument enclosure and securely tighten each of the cable gland connectors.
  - Do not over-tighten these connectors but make certain they are snug.
  - **DO NOT USE TOOLS!** Finger-tighten only!
2. Ensure any unused gland connectors are plugged and replace the rear panel.
3. Secure the rear panel with the 14 acorn nuts removed earlier.
4. Follow a diagonal pattern when tightening the acorn nuts.

# KEYPAD FUNCTIONS

The Model 225 indicator has 8 standard function keys, a full “QWERTY” alpha-numeric keypad, 4 soft (programmable) keys and 4 navigation keys with an interactive ENTER key. The keypad is used to enter commands and data into the indicator. This section describes each key along with its normal function. Refer to Figure No. 16 or the actual indicator while reading this section.



**The membrane keypad is not to be operated with pointed objects (pencils, pens, fingernails, etc). Damage to keypad resulting from this practice is NOT covered under warranty.**

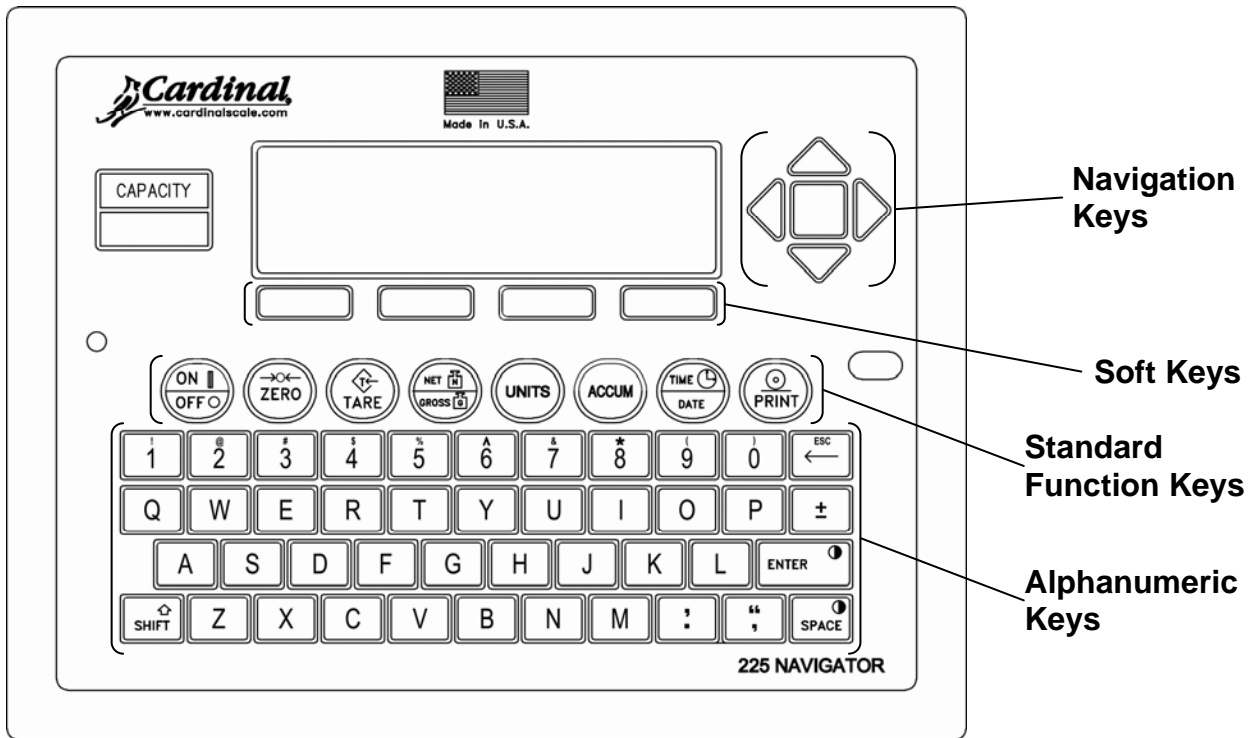

**Figure No. 16**

## Standard Function Keys

### ON/OFF KEY

Pressing this key when the indicator is off will apply power and turn it ON. If the indicator is already on, pressing this key will turn the indicator OFF.

### ZERO KEY

This key is used to reset the gross weight to zero. If the gross weight exceeds the preset limit for this key, an error message will be displayed when the key is pressed. The zero limit may be set to either 4% ( $\pm 2$ ) or 100% of scale capacity. The limit is set during Calibration and Setup of the scale.

# KEYPAD FUNCTIONS, CONT.

## Standard Function Keys, Cont.

### TARE KEY

This key is a dual function key. Pressing the **TARE** key alone (Pushbutton Tare mode) will cause the current gross weight to be stored as the new tare weight and cause the weight display to change to the net weight display mode (**NET** will be shown on right side of display). Pressing this key after entering a numeric value (Keypad Tare) will cause the value entered to be accepted as the new tare weight.

**NOTE:** Tare weights equal to or greater than scale capacity cannot be entered. In addition, the keypad tare weight division value must be the same as the scale division value. For example, a unit with .005 lb as the division value will display **ERROR** if you attempt to enter 1.003 for the tare weight.

### NET/GROSS KEY

This key is used to toggle between the Net and Gross weight mode. The selected mode is indicated by showing **G** for Gross weight or **NET** for Net weight on the display. Note that the display will show an error (**-NO TARE-**) and the indicator will remain in the Gross weight mode if the key is pressed and valid tare weight has not been entered.

### UNITS KEY

Pressing this key will change the weighing units to the alternate units if selected during the calibration and setup of the indicator. The available units of measure (**BASE UNITS=** and **CNVT UNITS=**) are enabled or disabled in calibration and setup. The available units include tons, pounds only, ounces, Tonnes (metric tons), kilograms, grams and custom. Note that not all combinations are supported.

### ACCUM KEY

This key is used to display the contents of the 32 ID accumulators, the total Gross and Net weight accumulators, the 200 ID storage accumulators, the Batch bin accumulators and the Count Function piece count accumulators. Note that the Total Gross, Total Net and Count accumulators are updated with every print command. Refer to the **NET/GROSS ACCUMULATORS, ID STORAGE OPERATION (ID ACCUMULATORS) OR COUNT OPERATION** sections of this manual for more information.

### TIME/DATE KEY

This key is used to program the time, date and consecutive number. Refer to the **TIME, DATE AND CONSECUTIVE NUMBER** section of this manual more information.

# KEYPAD FUNCTIONS, CONT.

## Standard Function Keys, Cont.

### PRINT KEY

Pressing this key will add the displayed Gross or Net weight or Piece Count to the associated accumulator and initiate the transmission of weight and other data selected during setup to the printer output port unless the continuous data feature of the port was enabled during calibration and setup.

**NOTE:** The indicator will not respond to the Print command unless the weight display is stable. If displaying Gross weight, the only weight printed is Gross weight. If displaying Net weight, the Gross, Tare, and Net weights are printed.

The Model 225 includes support for Cardinal's proprietary **VISUALIZER** Ticket and Label Generation Software. **VISUALIZER** is a PC based program that can design a ticket or label then download the ticket information to the indicator. The program also allows file transfer between the indicator and the PC.

The 225 allows six programmable formats in addition to the standard print tab settings format. Print formats are selected by using the **SHIFT** and **PRINT** keys in combination (refer to the Shift Key section for details). **NOTE:** When the **PRINT** key is pressed the indicator looks for the selected format. If no **VISUALIZER** ticket is found it reverts to the print tab settings.

```
#2
10:19 07/23/2008
100.00 lb G
20.00 lb T
80.00 lb N
      0.00 lb GROSS
ACCUM
      272.00 lb NET ACCUM
```

### SAMPLE TICKET

# KEYPAD FUNCTIONS, CONT.

## Alphanumeric Keys

The alphanumeric keys are used to enter commands and data into the indicator during Calibration and Setup as well as during normal operations.

## NUMERIC KEYS (1 to 9 and 0)

These keys are used to enter numeric data during the setup and calibration as well as during normal operation of the indicator. Note that they have alternate meanings. In the alphanumeric mode, when combined with the **SHIFT** key, their alternate meaning is output. For example, pressing the **SHIFT** key and then the **4** key will output the \$ dollar sign.

## ← /ESC KEY

This key has several functions. During Setup, when a setup parameter is displayed, pressing this key will "backup" to the previous selection. Also note that on prompts requiring a value to be entered, pressing the ← /ESC key will clear the value.

In normal operation, this key is used during numeric data input to delete a number entered. If the last number entered is incorrect, press the ← /ESC key once to delete the number. If more than the last number is incorrect, press the ← /ESC key for each number to be deleted. Note that if a number has not been entered, the indicator will ignore this key.

Pressing the ← /ESC key, while holding down the **SHIFT** key will exit the current setup function and perform the function described for the **ESC** key (e.g. ACCUMULATORS, To ZERO the Net Weight accumulator)

## QWERTY KEYS

These keys are used to enter alpha data during Calibration and Setup as well as during normal operations. Pressing the **SHIFT** key before pressing an alpha key will toggle the key to output its alternate meaning. For example, pressing the **SHIFT** key then the **A** key will output a lower case "a" (not a capital letter).

## ENTER KEY

The **ENTER** key serves several purposes. During Calibration and Setup (as well as during normal operations), pressing the key will retain the current setting and return the display to the menu display. It is also used when entering or changing data to signal the completion of data entry. The data entered will then be processed or saved.

During normal operations, it is used in combination with the **SHIFT** key to increase the LCD contrast.

## SPACE

This key is used to enter a blank space during alphanumeric data input for Calibration and Setup as well as during normal operations. When combined with the **SHIFT** key, it is used to decrease the display contrast.

# KEYPAD FUNCTIONS, CONT.

## Alphanumeric Keys, Cont.

### SHIFT

This key is used for several functions. It is used in combination with the Navigation **ENTER** key (red square key in center of the Navigation arrows) to enter the Calibration and Setup mode.

During Calibration and Setup (as well as during normal operations), pressing the key before pressing an alphanumeric key will toggle the key to output its alternate meaning. For example, when combined with an alphabetic key, the **SHIFT** key causes a lower case letter (not a capital letter) to be output.

## Shift Key Combinations

### SHIFT, ESC, ACCUM KEY

The 225 will retain and display on command the maximum weight value measured since the indicator has begun operation or since the maximum value was last cleared. The maximum value is displayed by pressing the **SHIFT** key, the **ESC** key and then the **ACCUM** key when the display is showing the **FUNCTION=** prompt. Press the **ENTER** key to exit and return to normal operation.

### SHIFT, ESC, PRINT KEY

This combination is used to *change* the selected print ticket format. Pressing the **SHIFT** key, the **ESC** key and then the **PRINT** key when the display is showing the **FUNCTION=** prompt. The display will change to show **PRINT=X**. Note that X is the current ticket format selected.

If the setting displayed is acceptable, press the **ENTER** key to exit and return to normal operation. Otherwise, using the numeric keys enter the new value for the ticket format and then press the **ENTER** key to exit and return to normal operation.

0 = Print Tab Settings

1 = Default Print Format    2 = VISUALIZER Ticket    3 = VISUALIZER Ticket

4 = VISUALIZER Ticket    5 = VISUALIZER Ticket    6 = VISUALIZER Ticket

In addition to using the above key combination to change the print ticket format, the operator (just prior to printing the ticket) can change the print ticket format at the end of the weighing operation. This is accomplished by performing the normal weighing operation and then pressing the desired format number (0, 1, 2, 3, 4, 5 or 6), followed by pressing the **PRINT** key.

<p><b>NOTE: When a print format is selected by either method, it will remain active until changed by the operator.</b></p>
--

## **KEYPAD FUNCTIONS, CONT.**

### **Shift Key Combinations, Cont.**

#### **SHIFT, ENTER KEY**

During normal operations, this combination is used to increase the LCD contrast. Refer to the DISPLAY CONTRAST ADJUSTMENT section of this manual for more information.

#### **SHIFT, SPACE KEY**

This combination is used during normal operations to decrease the display contrast. Refer to the DISPLAY CONTRAST ADJUSTMENT section of this manual for more information.

#### **SHIFT AND TARE KEY**

This combination is used during normal operations to display the current Tare weight. The tare weight will be displayed for 3 seconds and then the 225 will return to normal operations.

#### **SHIFT, UNITS KEY**

This combination will enter the Test mode. Refer to the TEST MODE AND ERASING MEMORY section of this manual for more information.

# KEYPAD FUNCTIONS, CONT.

## Soft Keys

### MEM KEY

This key is used by the ID Storage feature to enter permanent identification (ID) strings and perform other ID functions. Refer to the ID STORAGE OPERATION section of this manual for more information.

### ID KEY

This key is used to display and enter an alphanumeric identification (ID) string for use in printing and in the ID Storage feature. Refer to the ID STORAGE OPERATION section of this manual for more information.

### DELETE KEY

This key is used by the ID Storage feature to delete ID numbers. Refer to the ID STORAGE OPERATION section of this manual for more information.

### PRESET KEY

This key is used to enter the Preset Weight Comparators “PWC” weight and trim values. Refer to the PRESET WEIGHT COMPARATORS OPERATION section of this manual for more information.

### COUNT KEY

This key is used by the Counting feature. Refer to the Operation, COUNTING FEATURE OPERATION section of this manual for more information.



# ANNUNCIATORS

The annunciators are turned on to show that the indicator is in the mode corresponding to the annunciator label or that the status indicated by the label is active.



## →0← (ZERO)

This annunciator is turned on to show that the weight is within +/- 1/4 division of the center of zero.



## ▼ (STABLE)

This annunciator is turned on when the weight display is stable. This indicates the change in successive weight samples is less than the motion limits selected during Calibration and Setup.



## G (GROSS)

This annunciator is turned on to indicate that the displayed weight is the Gross weight.



## NET

This annunciator is turned on to show that the displayed weight is the Net weight (Gross weight less Tare weight).



## T

This annunciator is turned on to indicate that the displayed weight is the tare weight.

## ANNUNCIATORS, CONT.



### oz (OUNCES)

This annunciator is turned on to show that the displayed weight unit is ounces, for example,

99.0<sup>oz</sup>



### lb (POUNDS)

This annunciator is turned on to show that the displayed weight unit is pounds, for example,

347<sup>lb</sup>



### tn (TONS)

This annunciator is turned on to show that the displayed weight is avoirdupois tons, for example,

10.72<sup>tn</sup>



### g (GRAMS)

This annunciator is turned on to indicate that the displayed weight measurement is grams, for example,

1102<sup>g</sup>



### kg (KILOGRAMS)

This annunciator is turned on to indicate that the displayed weight is kilograms, for example,

1250<sup>kg</sup>



### t (TONNES "METRIC TONS")

This annunciator is turned on to show that the displayed weight measurement is metric tons, for example,

13.45<sup>t</sup>

# TIME, DATE AND CONSECUTIVE NUMBER

## 12-Hour Clock Format Selected in Setup (TIME=12)

1. With the indicator in normal operations mode, press the **TIME/DATE** key.
2. The display will change to show **TIME=XXXXXX**, where XXXXXX is the current time.
3. If the time displayed is correct, press the **ENTER** key and proceed to step 5.
4. Otherwise, using the numeric keys, enter the correct time (HHMMSS) and then press the **ENTER** key.

**IMPORTANT!** Note that with a 12-hour clock format, 8:30 AM or 8:30 PM are entered the same way, as 083000. The next prompt (**AM=**) determines whether AM or PM is printed on the ticket.

5. The display will change to show **AM=XXX**, where XXX is current setting (YES or NO).
6. If the setting displayed is acceptable, press the **ENTER** key and proceed to step 8.
7. Otherwise, press **YES** or **NO** (on the soft keys) and then the **ENTER** key to save the new setting and proceed to the next prompt.
8. The display will change to show **DATE = XXXXXX**. Note that XXXXXX is the current date displayed in the format selected during Calibration and Setup. See the **USA=** parameter in SETUP MENU #1.
9. If the date displayed is correct, press the **ENTER** key and proceed to step 11.
10. Otherwise, using the numeric keys, enter the correct date (in the format selected during Calibration and Setup, MMDDYY or DDMMYY) and then press the **ENTER** key.
11. The display will change to show **CNC NO=XXXXXX**, where XXXXXX is the current consecutive number.
12. If the consecutive number displayed is correct, press the **ENTER** key to return to normal operations.
13. Otherwise, using the numeric keys, enter the new consecutive number (6 digits max.) and then press the **ENTER** key to return to normal operations.

# TIME, DATE AND CONSECUTIVE NUMBER, CONT.

## 24-Hour Clock Format Selected in Setup (TIME=24)

1. With the indicator in normal operations mode, press the **TIME/DATE** key.
2. The display will change to show **TIME=XXXXXX**, where XXXXXX is the current time.
3. If the time displayed is correct, press the **ENTER** key and proceed to step 5.
4. Otherwise, using the numeric keys, enter the correct time (HHMMSS) and then press the **ENTER** key.

**IMPORTANT!** With a 24-hour clock format, AM and PM times are entered differently.

- When entering times before noon, the actual time is entered. For example, 8:30 AM would be entered (and would print on the ticket) as 083000.
  - When entering times after noon, you must add 12 to the time. For example, 8:30 PM would be entered (and would print on the ticket) as 203000.
5. The display will change to show **DATE = XXXXXX**. Note that XXXXXX is the current date displayed in the format selected during Calibration and Setup. See the **USA=** parameter in SETUP MENU #1.
  6. If the date displayed is correct, press the **ENTER** key and proceed to step 8.
  7. Otherwise, using the numeric keys, enter the correct date (in the format selected during Calibration and Setup, MMDDYY or DDMMYY) and then press the **ENTER** key.
  8. The display will change to show **CNC NO=XXXXXX**, where XXXXXX is the current consecutive number.
  9. If the consecutive number displayed is correct, press the **ENTER** key to return to normal operations.
  10. Otherwise, using the numeric keys, enter the new consecutive number (6 digits max.) and then press the **ENTER** key to return to normal operations.

## DISPLAY CONTRAST ADJUSTMENT

The Model 225 indicator uses a combination of the **SHIFT**, **ENTER** and **SPACE** keys to adjust the contrast of the LCD display.

### To Increase the LCD Contrast

1. With the indicator in normal operations mode, press and hold the **SHIFT** key and then press the **ENTER** key.
2. Repeat pressing the **ENTER** key to increase the contrast to the desired level.
3. When the LCD contrast is at the desired level, stop pressing the **ENTER** key and release the **SHIFT** key to save the setting and return to normal operating mode.

### To Reduce the LCD Contrast

1. With the indicator in normal operations mode, press and hold the **SHIFT** key and then press the **SPACE** key.
2. Repeat pressing the **SPACE** key to reduce the contrast to the desired level.
3. When the LCD contrast is at the desired level, stop pressing the **SPACE** key and release the **SHIFT** key to save the setting and return to normal operating mode.

# CALIBRATION AND SETUP

## Security Seals

A Category 1 Audit Trail is provided on the Model 225 with two event counters that increment when a change is made to features that are required by NTEP or OIML to be sealed. One counter is designated for calibration parameters and one is designated for configuration changes as required in NCWM Publication 14, 2007. Each event counter has a capacity to record 999 changes. The data for the counters is maintained in non-volatile memory. Refer to the VIEW AUDIT TRAIL COUNTERS section of this manual for more information.

If your local metrology laws require the use of physical sealing, the Model 225 has been designed with two types of security seals. One seal, a calibration inhibit jumper prevents unauthorized access to the calibration adjustments while the second seal (lead-wire) prevents the rear panel from being removed from the indicator to gain access to the jumper.

**NOTE:** The calibration inhibit jumper (P8) is located on the main printed circuit board and can **only** be accessed by removing the rear panel of the indicator.

The following setup parameters CAN NOT be changed with the calibration inhibit jumper (P8) installed.

### On SETUP/REVIEW MENU

3. CALIBRATE SCALE
--------------------

### On SETUP MENU #1

1. USA	4. OIML
2. NSC	8. NO OF SCALES
3. LFT	9. TOTALIZE

### On Setup Menu #2

5. CALIBRATE
--------------

### On Setup Menu #3

G/N ACCUMS
------------

### On 4. SETUP SCALE MENU #1

1. BASE UNITS	4. Z LIMIT	7. STABLE
2. CNVT UNITS	5. PWR UP Z	8. STBL CNT
3. Z TRACK	6. SAMPLES	9. WT INTERVALS

### On 4. SETUP SCALE MENU #2

1. FILTER	3. FBRK	5. DPP
2. FMAX	4. INTERVAL	6. CAP

**NOTE:** With the calibration inhibit jumper installed, a long error beep with CAL SEAL displayed will occur when attempting to change the above listed parameters.

## CALIBRATION AND SETUP, CONT.

Your 225 indicator has been thoroughly tested and calibrated before being shipped to you. If you received the indicator attached to a scale, calibration is not necessary. If the indicator is being connected to a scale for the first time or recalibration is necessary for other reasons, proceed as indicated.

Calibration and Setup of the indicator is accomplished entirely by the keypad. However, it may require changing the position of the calibration inhibit jumper depending on the method of sealing required by your local metrology laws.

The calibration inhibit jumper (**P8**) is located on the main printed circuit board and can **only** be accessed by removing the rear panel. Refer to Figure No. 15 for the location of jumper P8.

During the calibration and setup process, it is necessary to enter operational parameters and data using the indicator keypad.

- Pressing the **ENTER** key without entering a new value will retain the current setting and return the display to the menu display.
- To change a setting, enter or select a new value and then press the **ENTER** key. The new setting will be saved and the display will return to the menu display.
- Note that pressing the ← /**ESC** key on YES or NO prompts will “backup” to the previous selection. Also note that on prompts requiring a value to be entered, pressing the ← /**ESC** key will clear the value.

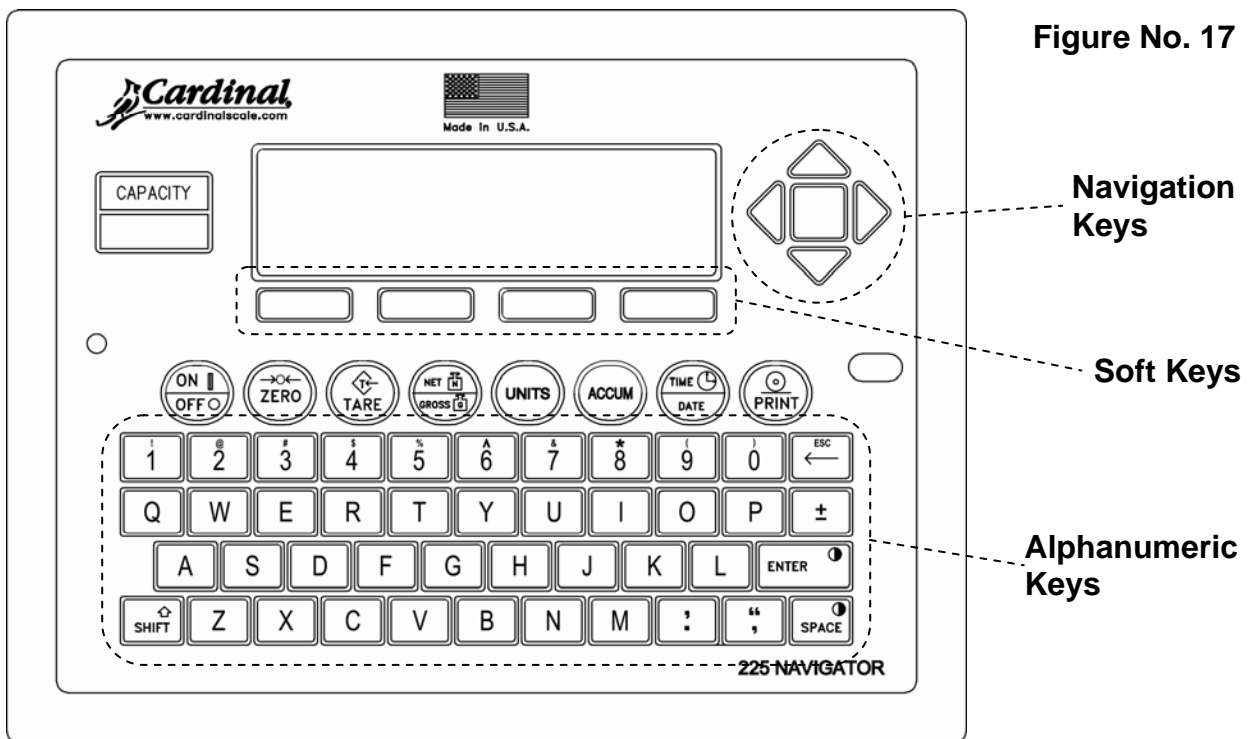

Figure No. 17

Navigation  
Keys

Soft Keys

Alphanumeric  
Keys



**CAUTION!** The membrane keypad is not to be operated with pointed objects (pencils, pens, fingernails, etc). Damage to keypad resulting from this practice will NOT be covered under warranty.

## CALIBRATION AND SETUP, CONT.

With the indicator ON, press the **SHIFT** key and then press the Navigation **ENTER** key (red square key in center of the Navigation arrows). The display will change to show the SETUP/REVIEW MENU.

```
          SETUP/REVIEW MENU
1. ENTER CALIBRATION AND SETUP
2. VIEW AUDIT TRAIL COUNTERS
3. CALIBRATE SCALE 1
                                     9. DEL CUSTOM TICKET
                                     10. PRINT SETUP
Enter Selection: 1  [F4]EXIT
```

### 1. ENTER CALIBRATION AND SETUP

#### SETUP MENU #1

With the SETUP/REVIEW MENU displayed, press the **1** key and then the **ENTER** key. The display will change to show SETUP MENU #1.

```
          SETUP MENU #1
1. USA=XXX          6. CLR TARE=XXX
2. NSC=XXX          7. CLEAR ID=XXX
3. LFT=XXX          8. NO OF SCALES=X
4. N/A              9. TOTALIZE=XXX
5. TIME=XX          10. MODE OF OP=0  NORM
Enter Selection: 0  [F4]NEXT [F5]EXIT
```

#### 1. USA=XXX (DOMESTIC or INTERNATIONAL)

With SETUP MENU #1 displayed the current setting for the USA= parameter will be shown. Note that XXX is the current value. If the setting displayed is acceptable, proceed to the next setup parameter.

Otherwise, press the **1** key, the **ENTER** key, **YES** or **NO** (on the soft keys) and then the **ENTER** key to save the new setting and return to SETUP MENU #1.

USA=YES (Domestic)

DATE = MM/DD/YY

Z LIMIT = NO

CAP + 5% to OC

USA=NO (International)

DATE = DD/MM/YY

Z LIMIT = YES

CAP + 9 grads to OC

ETR able = YES

PT printed with tare. Lamp test on power up. Lorry Weigher Operation (Any MODE OF OP but 1 or 6).

NSC (Australia NSC Requirements) setup parameter selection allowed

## CALIBRATION AND SETUP, CONT.

### 2. NSC=XXX (AUSTRALIA NSC REQUIREMENTS)

**NOTE:** In countries requiring the 225 to meet Australia NSC requirements, the USA= parameter must be set for international use (USA=NO) to allow the 2. NSC=XXX setup parameter selection.

With SETUP MENU #1 displayed the current setting for the NSC= parameter will be shown. Note that XXX is the current value. If the setting displayed is acceptable, proceed to the next setup parameter.

Otherwise, press the **2** key, the **ENTER** key, **YES** or **NO** (on the soft keys) and then the **ENTER** key to save the new setting and return to SETUP MENU #1.

NSC=YES

Australia NSC Requirements  
Enabled

NSC=NO

Australia NSC Requirements  
Disabled

### 3. LFT=XXX (LEGAL FOR TRADE)

With SETUP MENU #1 displayed the current setting for the LFT= parameter will be shown. Note that XXX is the current value. If the setting displayed is acceptable, proceed to the next setup parameter.

Otherwise, press the **3** key, the **ENTER** key, **YES** or **NO** (on the soft keys) and then the **ENTER** key to save the new setting and return to SETUP MENU #1.

LFT=YES

Interval Settings (INTERVAL)  
allowed are 1, 2, 5, 10, 20, 50

LFT=NO

Interval Setting (INTERVAL) is  
selectable from 1 to 99.

**NOTE:** If LFT=YES and USA=YES

Division must be 100 to 10,000  
Z TRACK = .5 or 0 to 3  
Inhibit serial data during input  
DATE = MM/DD/YY  
Z LIMIT = NO  
CAP + 5% to OC

**NOTE:** If LFT=NO

Enables the Converted Units Net  
Weight print feature

**NOTE:** If LFT=YES and USA=NO

STABLE = 1  
DATE = DD/MM/YY  
Z TRACK = 0.5  
Z LIMIT = yes  
CAP + 9 grads to OC  
PT printed with tare  
Lamp test on power up



## CALIBRATION AND SETUP, CONT.

### 4. N/A

### 5. TIME=XX (CLOCK TIME FORMAT)

With SETUP MENU #1 displayed the current setting for the TIME= parameter will be shown. Note that XX is the current value. If the setting displayed is acceptable, proceed to the next setup parameter.

Otherwise, press the **5** key, the **ENTER** key and then using the numeric keys, enter 12 or 24 and then press the **ENTER** key to save the new setting and return to the SETUP MENU #1.

TIME=12

12 hour clock (AM/PM)

(8:30 PM will print as 08:30 PM)

TIME=24

24 hour clock

(8:30 PM will print as 20:30)

### 6. CLR TARE=XXX (CLEAR TARE)

With SETUP MENU #1 displayed the current setting for the CLR TARE= parameter will be shown. Note that XXX is the current value. If the setting displayed is acceptable, proceed to the next setup parameter.

Otherwise, press the **6** key, the **ENTER** key, **YES** or **NO** (on the soft keys) and then the **ENTER** key to save the new setting and return to SETUP MENU #1.

CLR TARE=YES

Automatically clears Stored Tare  
when Net weight goes below zero

CLR TARE=NO

Stored Tare is not cleared when  
Net weight goes below zero

#### The following is a typical example of the Clear Tare feature in use.

1. Place container on scale, then press the **TARE** key.
2. Load container with item to be weighed and perform normal weighing operation.
3. Remove load (item *AND* container) from scale.
4. Scale weight returns to below zero (weight of container) and is then reset to zero.
5. Operator is required to repeat step 1 before next weighing operation.

### 7. CLEAR ID=XXX (CLEAR ID)

With SETUP MENU #1 displayed the current setting for the CLEAR ID= parameter will be shown. Note that XXX is the current value. If the setting displayed is acceptable, proceed to the next setup parameter.

Otherwise, press the **7** key, the **ENTER** key, **YES** or **NO** (on the soft keys) and then the **ENTER** key to save the new setting and return to SETUP MENU #1.

CLR ID=YES

Automatically clears ID after print

CLR ID= NO

ID is not cleared after print

## CALIBRATION AND SETUP, CONT.

### 8. NO OF SCALES=X (NUMBER OF SCALES)

With SETUP MENU #1 displayed the current setting for the NO OF SCALES= parameter will be shown. Note that X is the current value. If the setting displayed is acceptable, proceed to the next setup parameter.

Otherwise, press the **8** key, the **ENTER** key and then using the numeric keys, enter the number of scales and then press the **ENTER** key to save the new setting and return to SETUP MENU #1. Allowable values are 1, 2 or 3.



**NOTE:** Support for more than 1 scale requires the 225-DS (Dual Scale) Card. If 2 or 3 are entered for number of scales, the 225 will check for additional scales. If additional scales are not found, it will display an error message and default back to 1 scale.

### 9. TOTALIZE=XXX (SCALE TOTALIZER)

With the 225-DS (Dual Scale) Card installed and the number of scales set for 2 or 3, the 225 can sum the weights of two or more scales and make the total available to be displayed. The totalizer can be referenced as if it were another scale. **NOTE:** The totalizer's scale number will always be 4 regardless of the actual number of scales attached to the indicator.

With SETUP MENU #1 displayed the current setting for the TOTALIZE= parameter will be shown. Note that XXX is the current value. If the setting displayed is acceptable, proceed to the next setup parameter.

Otherwise, press the **9** key, the **ENTER** key, **YES** or **NO** (on the soft keys) and then the **ENTER** key to save the new setting and return to SETUP MENU #1.

TOTALIZE=YES  
Scale Totalizer Enabled

TOTALIZE=NO  
Scale Totalizer Disabled



**NOTE:** All scales to be included in the totalizer must have identical settings for: BASE UNITS, CNVT UNITS, INTERVAL, DDP, SAMPLES, STABLE and STBL CNT. If these are not the same, an error message will be displayed.

## CALIBRATION AND SETUP, CONT.

### 10. MODE OF OP=X XXXX (MODE OF OPERATION)

With SETUP MENU #1 displayed the current setting for the MODE OF OP= parameter will be shown. Note that X is the current value and XXXX is the mode of operation abbreviation.

If the setting displayed is acceptable, press **NEXT** (Navigation Keys ▾ Down Arrow) to proceed to SETUP MENU #2 or press **EXIT** (Navigation Keys △ UP Arrow) to return to the SETUP/REVIEW MENU.

Otherwise, press the **1** and **0** keys and then the **ENTER** key. The display will change to show the Mode Of Operation Menu.

### 0. Normal Indicator (Normal Indicator = NORM)

Press the **0** key, the **ENTER** key and then press **EXIT** (Navigation Keys △ UP Arrow) to exit and return to SETUP MENU #1. Press **NEXT** (Navigation Keys ▾ Down Arrow) to proceed to the next display, SETUP MENU #2.

### 1. ID Storage (ID Storage = IDS)

Press the **1** key and then the **ENTER** key to proceed to the ID Storage Menu. Refer to the ID STORAGE SETUP, Mode Of Operation = 1 (ID Storage) section of this manual.

### 2. Digital Fill Ctrl (Digital Fill Control = DFC)

Press the **2** key and then the **ENTER** key to proceed to the Digital Fill Control Menu. Refer to the 225 Digital Fill Control manual.

### 3. Preset Weight Comp (Preset Weight Comp = PWC)

Press the **3** key and then the **ENTER** key to proceed to the Preset Weight Comparator Menu. Refer to the PRESET WEIGHT COMPARATORS SETUP, Mode Of Operation = 3 (Preset Weight Comp) section of this manual.

### 4. Check Weigher (Check Weigher = CHW)

Press the **4** key and then the **ENTER** key to proceed to the Check Weigher Menu. Refer to the 225 Check Weigher manual.

### 5. Batcher (Batcher = BATR)

Press the **5** key and then the **ENTER** key to proceed to the Batcher Menu. Refer to the 225 Batcher manual.

### 6. Package Weigher (Package Weigher = PKW)

Press the **6** key and then the **ENTER** key to proceed to the Package Weigher Menu. Refer to the 225 Package Weigher manual.

# CALIBRATION AND SETUP, CONT.

## SETUP MENU #2

### SERIAL INPUT/OUTPUT SETUP

With SETUP MENU #1 displayed, press **NEXT** (Navigation Keys ▾ Down Arrow) to proceed to SETUP MENU #2.

```
SETUP MENU #2
1. SERIAL
2. DIO
3. PRINT TABS
4. SETUP SCALE 1
5. CALIBRATE 1
Enter Selection: 0 [NEXT] [PREV]
```

#### 1. SERIAL (SERIAL INPUT/OUTPUT)

With SETUP MENU #2 displayed, press the **1** key and then the **ENTER** key to proceed to the Serial Menu.

```
Serial Menu
1. COM0
2. COM1
3. COM2
4. COM3
Enter Selection: 0 [EXIT]
```

#### 1. COM0 (COM0)

With the Serial Menu displayed, press the **1** key and then the **ENTER** key to proceed to the COM0 SETUP MENU.

```
COM0 SETUP MENU
1. BAUD=X XXXXXX      6. TYPE=X XXXXXXXXXXXX
2. PARITY=X XXXX      7. SCALE = 0
3. BITS=X             8. Gross Only = NO
4. STOPS=X
5. CONT=XXX
Enter Selection: 0 [EXIT]
```

## CALIBRATION AND SETUP, CONT.

### 1. BAUD=X XXXXXX (COM0 PORT BAUD RATE)

With the COM0 SETUP MENU displayed the current setting for the BAUD= parameter will be shown. Note that X is the current value and XXXXXX is the actual baud rate. If the setting displayed is acceptable, proceed to the next setup parameter.

Otherwise, press the **1** key, the **ENTER** key and then using the numeric keys, enter the value for the COM0 port baud rate and then press the **ENTER** key to save the new setting and return to the COM0 SETUP MENU. Allowable values are 0 through 13.

0 = 300	4 = 4800	8 = 28800	12 = 115200
1 = 600	5 = 9600	9 = 38400	13 = 230400
2 = 1200	6 = 14400	10 = 57600	
3 = 2400	7 = 19200	11 = 76000	

### 2. PARITY=X XXXX (COM0 PARITY RATE)

With the COM0 SETUP MENU displayed the current setting for the PARITY= parameter will be shown. Note that X is the current value and XXXX is the description. If the setting displayed is acceptable, proceed to the next setup parameter.

Otherwise, press the **2** key, the **ENTER** key and then using the numeric keys, enter the value for the COM0 parity rate and then press the **ENTER** key to save the new setting and return to the COM0 SETUP MENU. Allowable values are 0, 1 or 2.

0 = NONE (No Parity)	1 = Odd Parity	2 = Even Parity
----------------------	----------------	-----------------

### 3. BITS=X (COM0 DATA BITS)

With the COM0 SETUP MENU displayed the current setting for the BITS= parameter will be shown. Note that X is the current value. If the setting displayed is acceptable, proceed to the next setup parameter.

Otherwise, press the **3** key, the **ENTER** key and then using the numeric keys, enter the value for the COM0 data bits and then press the **ENTER** key to save the new setting and return to the COM0 SETUP MENU. Allowable values are 7 or 8.

### 4. STOPS=X (COM0 STOP BITS)

With the COM0 SETUP MENU displayed the current setting for the STOPS= parameter will be shown. Note that X is the current value. If the setting displayed is acceptable, proceed to the next setup parameter.

Otherwise, press the **4** key, the **ENTER** key and then using the numeric keys, enter the value for the COM0 stop bits and then press the **ENTER** key to save the new setting and return to the COM0 SETUP MENU. Allowable values are 1 or 2.

## CALIBRATION AND SETUP, CONT.

### 5. CONT=XXX (COM0 CONTINUOUS OUTPUT)

With the COM0 SETUP MENU displayed the current setting for the CONT= parameter will be shown. Note that XXX is the current value. If the setting displayed is acceptable, proceed to the next setup parameter.

Otherwise, press the **5** key, the **ENTER** key, **YES** or **NO** (on the soft keys) and then the **ENTER** key to save the new setting and return to the COM0 SETUP MENU.

CONT=YES

Continuous Output Enabled

CONT=NO

Continuous Output Disabled



**NOTE:** If you selected CONT=NO (Continuous Output Disabled) for the CONT= parameter, the following setup parameters 6. TYPE=, 7. SCALE= and 8. Gross Only= will NOT be shown on the COM0 SETUP MENU.

### 6. TYPE=X XXXXXXXXXXXX (COM0 CONTINUOUS OUTPUT SELECTION)

With the COM0 SETUP MENU displayed the current setting for the TYPE= parameter will be shown. Note that X is the current value and XXXXXXXXXXXX is the description. If the setting displayed is acceptable, proceed to the next setup parameter.

Otherwise, press the **6** key, the **ENTER** key and then using the numeric keys, enter the value for the COM0 continuous output selection and then press the **ENTER** key to save the new setting and return to the COM0 SETUP MENU. Allowable values are 0 through 6 and 10.

0 = SMA

3 = IQ355

6 = SB250/500M

1 = SB400

4 = NUMERIC WT

10 = SB200

2 = TOLEDO (See Note) 5 = SB500

**NOTE:** If you selected 2. TOLEDO for the TYPE= parameter, the following setup menu parameters will be shown after pressing the **ENTER** key:

```
PRINTR CONTINUOUS OUTPUT SELECTION
TOLEDO FORMAT SELECTION MENU
0. 8530 no CKSUM
1. SHORT no CKSUM
2. 8530 with CKSUM
3. SHORT with CKSUM

TOLEDO Format=X
```

## CALIBRATION AND SETUP, CONT.

With the PRINTR CONTINUOUS OUTPUT SELECTION menu displayed the current setting for the TOLEDO Format= parameter will be shown. Note that X is the current value. If the setting displayed is acceptable, press the **ENTER** key to save the new setting and return to the COM0 SETUP MENU.

Otherwise, using the numeric keys, enter the value for the TOLEDO Format and then press the **ENTER** key to save the new setting and return to COM0 SETUP MENU. Allowable values are 0, 1, 2, or 3.

### 7. SCALE=X (SCALE USED FOR COM0 DATA)

With the COM0 SETUP MENU displayed the current setting for the SCALE= parameter will be shown. Note that X is the current value. If the setting displayed is acceptable, proceed to the next setup parameter.

Otherwise, press the **7** key, the **ENTER** key and then using the numeric keys, enter the value for the scale for continuous data output and then press the **ENTER** key to save the new setting and return to the COM0 SETUP MENU. Allowable values are 0 through 5. **NOTE:** Scale 1 is the default setting. Also note, 4 is the Scale Totalizer.

0 = Current Scale	3 = Scale 3
1 = Scale 1	4 = Total
2 = Scale 2	5 = All Scales (TYPE = 5 = SB500 or 6 = SB250/500M)

### 8. Gross Only=XXX (GROSS WEIGHT ONLY OUTPUT TO COM PORTS)

With the COM0 SETUP MENU displayed the current setting for the Gross Only= parameter will be shown. Note that XXX is the current value. If the setting displayed is acceptable, press **EXIT** (Navigation Keys  $\Delta$  UP Arrow) to return to the Serial Menu.

Otherwise, press the **8** key, the **ENTER** key, **YES** or **NO** (on the soft keys) and then the **ENTER** key to save the new setting and return to the COM0 SETUP MENU.

Gross Only=YES	Gross Only=NO
GROSS weight is transmitted on all COM ports.	Displayed weight is transmitted on all COM ports.



**NOTE:** If you selected 5. SB500 or 6. SB250/500M for the TYPE= parameter, the following setup parameters Manual Mode= and Thres Wt = will be shown on the COM0 SETUP MENU.

## CALIBRATION AND SETUP, CONT.

### 9. Manual Mode=XXX (MANUAL LIGHT MODE)

With the COM0 SETUP MENU displayed the current setting for the Manual Mode= parameter will be shown. Note that XXX is the current value. If the setting displayed is acceptable, press **EXIT** (Navigation Keys  $\Delta$  UP Arrow) to return to the Serial Menu.

Otherwise, press the **9** key, the **ENTER** key, **YES** or **NO** (on the soft keys) and then the **ENTER** key to save the new setting and return to the COM0 SETUP MENU.

Manual Mode=YES

Manual Mode is Enabled. Pressing **START/STOP** key will toggle traffic light between Green and Red.

Manual Mode=NO

Manual Mode is Disabled. Threshold weight is used to toggle light between Green and Red.

### 10. Thres Wt=XXXXXXXX (THRESHOLD WEIGHT FOR AUTO MODE)

With the COM0 SETUP MENU displayed the current setting for the Thres Wt= parameter will be shown. Note that XXXXXXXX is the current value. If the setting displayed is acceptable, press **EXIT** (Navigation Keys  $\Delta$  UP Arrow) to return to the Serial Menu.

Otherwise, press the **1** and **0** keys, the **ENTER** key and then using the numeric keys, enter the value for the threshold weight<sup>1</sup> used to control the traffic light auto mode and then press the **ENTER** key to save the new setting and return to the COM0 SETUP MENU. Note that entering 0 disables the traffic light auto mode.

- <sup>1</sup> If scale gross weight is less than or equal to threshold weight, traffic light will be Green. When scale gross weight is greater than threshold weight, traffic light will be Red.



**NOTE:** If manual light mode is disabled (Manual Mode=NO) and 0 is entered for the threshold weight (Thres Wt =0), the traffic light feature will be disabled (turned off).

### COM0 Setup Completed

The COM0 setup has been completed, press **EXIT** (Navigation Keys  $\Delta$  UP Arrow) to return to the Serial Menu and proceed to the COM port (serial port) setup.



# CALIBRATION AND SETUP, CONT.

The following describes the setup for the 225 COM ports (Serial Ports). Although the three (3) COM ports can be configured differently, they have the same setup parameters. In the setup menus shown and parameters described, COM1 (Serial Port 1) is referenced. Substitute the COM port number you are configuring for the number shown.

```
Serial Menu
1. COM0
2. COM1
3. COM2
4. COM3

Enter Selection: 0 [ENTER] EXIT
```

## 2. COM1 (COM1, SERIAL PORT 1)

With the Serial Menu displayed, press the **2** key and then the **ENTER** key to proceed to the COM1 SETUP MENU.

```
COM1 SETUP MENU
1. BAUD=X XXXXXX      6. TYPE=X XXXXXXXXXXXX
2. PARITY=X XXXX     7. SCALE=0
3. BITS=
4. STOPS=X
5. CONT=XXX
Enter Selection: 0 [ENTER] EXIT
```

### 1. BAUD=X XXXXXX (COM1 BAUD RATE)

With the COM1 SETUP MENU displayed the current setting for the **BAUD=** parameter will be shown. Note that X is the current value and XXXXXX is the actual baud rate. If the setting displayed is acceptable, proceed to the next setup parameter.

Otherwise, press the **1** key, the **ENTER** key and then using the numeric keys, enter the value for the COM0 port baud rate and then press the **ENTER** key to save the new setting and return to the COM1 SETUP MENU. Allowable values are 0 through 13.

0 = 300	4 = 4800	8 = 28800	12 = 115200
1 = 600	5 = 9600	9 = 38400	13 = 230400
2 = 1200	6 = 14400	10 = 57600	
3 = 2400	7 = 19200	11 = 76000	

## CALIBRATION AND SETUP, CONT.

### 2. PARITY=X XXXX (COM1 PARITY RATE)

With the COM1 SETUP MENU displayed the current setting for the PARITY= parameter will be shown. Note that X is the current value and XXXX is the description. If the setting displayed is acceptable, proceed to the next setup parameter.

Otherwise, press the **2** key, the **ENTER** key and then using the numeric keys, enter the value for the COM0 parity rate and then press the **ENTER** key to save the new setting and return to the COM1 SETUP MENU. Allowable values are 0, 1 or 2.

0 = NONE (No Parity)      1 = Odd Parity      2 = Even Parity

### 3. BITS=X (COM1 DATA BITS)

With the COM1 SETUP MENU displayed the current setting for the BITS= parameter will be shown. Note that X is the current value. If the setting displayed is acceptable, proceed to the next setup parameter.

Otherwise, press the **3** key, the **ENTER** key and then using the numeric keys, enter the value for the COM0 data bits and then press the **ENTER** key to save the new setting and return to the COM1 SETUP MENU. Allowable values are 7 or 8.

### 4. STOPS=X (COM1 STOP BITS)

With the COM1 SETUP MENU displayed the current setting for the STOPS= parameter will be shown. Note that X is the current value. If the setting displayed is acceptable, proceed to the next setup parameter.

Otherwise, press the **4** key, the **ENTER** key and then using the numeric keys, enter the value for the COM0 stop bits and then press the **ENTER** key to save the new setting and return to the COM1 SETUP MENU. Allowable values are 1 or 2.

### 5. CONT=XXX (COM1 CONTINUOUS OUTPUT)

With the COM1 SETUP MENU displayed the current setting for the CONT= parameter will be shown. Note that XXX is the current value. If the setting displayed is acceptable, proceed to the next setup parameter.

Otherwise, press the **5** key, the **ENTER** key, **YES** or **NO** (on the soft keys) and then the **ENTER** key to save the new setting and return to the COM1 SETUP MENU.

CONT=YES

Continuous Output Enabled

CONT=NO

Continuous Output Disabled

## CALIBRATION AND SETUP, CONT.

### 6. TYPE=X XXXXXXXXXXXX (COM1 CONTINUOUS OUTPUT SELECTION)

With the COM1 SETUP MENU displayed the current setting for the TYPE= parameter will be shown. Note that X is the current value and XXXXXXXXXXXX is the description. If the setting displayed is acceptable, proceed to the next setup parameter.

Otherwise, press the **6** key, the **ENTER** key and then using the numeric keys, enter the value for the COM0 continuous output selection and then press the **ENTER** key to save the new setting and return to the COM1 SETUP MENU. Allowable values are 0 through 7 and 9.

0 = SMA	4 = NUMERIC WT	9 = TALLEY (See Note 2)
1 = SB400	5 = SB500	
2 = TOLEDO (See Note 1)	6 = SB250/500M	
3 = IQ355		

**NOTE 1!** If you selected 2. TOLEDO for the TYPE= parameter, the following setup menu parameters will be shown after pressing the **ENTER** key:

```
COM1 CONTINUOUS OUTPUT SELECTION
0. 8530 no CKSUM
1. SHORT no CKSUM
2. 8530 with CKSUM
3. SHORT with CKSUM

TOLEDO Format=X
```

With the COM1 CONTINUOUS OUTPUT SELECTION menu displayed the current setting for the TOLEDO Format= parameter will be shown. Note that X is the current value. If the setting displayed is acceptable, press the **ENTER** key to save the new setting and return to the COM1 SETUP MENU.

Otherwise, using the numeric keys, enter the value for the TOLEDO Format and then press the **ENTER** key to save the new setting and return to COM1 SETUP MENU. Allowable values are 0, 1, 2, or 3.

**NOTE 2!** 9=TALLEY is displayed only if USA=NO and MODE OF OP=0, 2, 3, 4 or 5. Refer to the ELECTRONIC TALLEY ROLL section of this manual.

## CALIBRATION AND SETUP, CONT.

### 7. SCALE=X (SCALE USED FOR COM1 DATA)

With the COM1 SETUP MENU displayed the current setting for the SCALE= parameter will be shown. Note that X is the current value. If the setting displayed is acceptable, proceed to the next setup parameter.

Otherwise, press the **7** key, the **ENTER** key and then using the numeric keys, enter the value for the scale the COM0 will receive data from and then press the **ENTER** key to save the new setting and return to the COM1 SETUP MENU. Allowable values are 1 through 4. **NOTE:** Scale 1 is the default setting. Also, note, 0 is the current selected scale and 4 is the TOTAL weight in multi-scale applications with totalizer.



**NOTE:** If you selected 5. SB500 for the TYPE= parameter, the following setup parameters Manual Mode= and Thres Wt = will be shown on the COM 1 SETUP MENU.

### 9. Manual Mode=XX (MANUAL LIGHT MODE)

With the COM 1 SETUP MENU displayed the current setting for the Manual Mode= parameter will be shown. Note that XXX is the current value. If the setting displayed is acceptable, press **EXIT** (Navigation Keys  $\Delta$  UP Arrow) to return to the Serial Menu.

Otherwise, press the **9** key, the **ENTER** key, **YES** or **NO** (on the soft keys) and then the **ENTER** key to save the new setting and return to the COM 1 SETUP MENU.

Manual Mode=YES

Manual Mode is Enabled. Pressing **START/STOP** key will toggle traffic light between Green and Red.

Manual Mode=NO

Manual Mode is Disabled. Threshold weight is used to toggle light between Green and Red.

## CALIBRATION AND SETUP, CONT.

### 10. Thres Wt=XXXXXXXX (THRESHOLD WEIGHT FOR AUTO MODE)

With the COM 1 SETUP MENU displayed the current setting for the Thres Wt = parameter will be shown. Note that XXXXXXXX is the current value. If the setting displayed is acceptable, press **EXIT** (Navigation Keys  $\Delta$  UP Arrow) to return to the Serial Menu.

Otherwise, press the **1** and **0** keys, the **ENTER** key and then using the numeric keys, enter the value for the threshold weight<sup>1</sup> used to control the traffic light auto mode and then press the **ENTER** key to save the new setting and return to the COM 1 SETUP MENU. Note that entering 0 disables the traffic light auto mode.

- <sup>1</sup> If scale gross weight is less than or equal to threshold weight, traffic light will be Green. When scale gross weight is greater than threshold weight, traffic light will be Red.



**NOTE:** If manual light mode is disabled (Manual Mode=NO) and 0 is entered for the threshold weight (Thres Wt=0), the traffic light feature will be disabled (turned off).

### COM1 (Serial Port 1) Setup Completed

The COM1 (Serial Port 1) setup has been completed, press **EXIT** (Navigation Keys  $\Delta$  UP Arrow) to return to the Serial Menu and proceed to the COM2 or COM3 port setup.

```
Serial Menu
1. COM0
2. COM1
3. COM2
4. COM3

Enter Selection: 0 EXIT
```

When setup of all of the COM ports has been completed, press **EXIT** (Navigation Keys  $\Delta$  UP Arrow) to exit and return to the SETUP MENU #2.

With the SETUP MENU #2 displayed,

- Proceed to the next setup parameter.
- Press **PREV** (Navigation Keys  $\Delta$  UP Arrow) to return to SETUP MENU #1.
- Press **NEXT** (Navigation Keys  $\nabla$  Down Arrow) to proceed to the SETUP MENU #3.

# CALIBRATION AND SETUP, CONT.

## DIO SETUP (PWC Status)



**IMPORTANT!** The DIO SETUP (PWC Status) cannot be selected if Mode of Operation = 0, Normal Indicator is enabled.

With the SETUP MENU #1 displayed, press **NEXT** (Navigation Keys ▾ Down Arrow) to proceed to SETUP MENU #2.

```
          SETUP MENU #2
1. SERIAL
2. DIO
3. PRINT TABS
4. SETUP SCALE 1
5. CALIBRATE 1
Enter Selection: 0  ▣NEXT  ▣PREV
```

## 2. DIO (TOGGLE PWC STATUS)

With the SETUP MENU #2 displayed, press the **2** key and then the **ENTER** key to proceed to the DIO SETUP MENU.

```
          DIO SETUP MENU
PWC1-OFF  PWC6-OFF  PWC11-OFF  PWC16-OFF
PWC2-OFF  PWC7-OFF  PWC12-OFF  17. ALL OFF
PWC3-OFF  PWC8-OFF  PWC13-OFF  18. ALL ON
PWC4-OFF  PWC9-OFF  PWC14-OFF
PWC5-OFF  PWC10-OFF PWC15-OFF
Enter PWC # to Toggle: 0  ▣EXIT
```

With the DIO SETUP MENU displayed, the current “state before cutoff” status of the 16 Preset Weight Comparators (PWC) will be shown. If the status displayed is acceptable, press **EXIT** (Navigation Keys △ UP Arrow) to exit and return to the SETUP MENU #2.

Otherwise, press the PWC number, 17 or 18 to toggle the status (turn ON, relay closed or OFF, relay open) and then press the **ENTER** key to save the new setting.

**IMPORTANT!** When power to the indicator is lost, the output goes to the OFF state.

## CALIBRATION AND SETUP, CONT.

### DIO Setup Completed

When the status of all Preset Weight Comparators has been set, press **EXIT** (Navigation Keys  $\Delta$  UP Arrow) to exit and return to the SETUP MENU #2.



With the SETUP MENU #2 displayed,

- Proceed to the next setup parameter.
- Press **PREV** (Navigation Keys  $\Delta$  UP Arrow) to return to SETUP MENU #1.
- Press **NEXT** (Navigation Keys  $\nabla$  Down Arrow) to proceed to the SETUP MENU #3.

# CALIBRATION AND SETUP, CONT.

## PRINT TABS SETUP

With SETUP MENU #1 displayed, press **NEXT** (Navigation Keys ▾ Down Arrow) to proceed to SETUP MENU #2.

```
          SETUP MENU #2
1. SERIAL
2. DIO
3. PRINT TABS
4. SETUP SCALE 1
5. CALIBRATE 1
Enter Selection: 0  ▾NEXT ▾PREV
```

## 3. PRINT TABS (PRINT TABS SETTING)

With the SETUP MENU #2 displayed, press the **3** key and then the **ENTER** key to proceed to PRINT TABBING MENU #1.

```
          PRINT TABBING MENU #1
1. PORT=X XXXXXXXX      6. TIME=YY.XX
2. PRT BEG=XXXXXXXXXXXX 7. DATE=YY.XX
3. AUTO LF=XXX          8. CNC NO=YY.XX
4. ENDING LF=XX         9. GROSS=YY.XX
5. PRT END=XXXXXXXXXXXX 10. TARE=YY.XX
Enter Selection: 0  ▾NEXT ▾EXIT
```

## 1. PORT=X XXXXXXXX (SELECT PORT FOR PRINTER)

With PRINT TABBING MENU #1 displayed the current setting for the **PORT=** parameter will be shown. Note that X is the current value and XXXXXXXX is the description. If the setting displayed is acceptable, proceed to the next setup parameter.

Otherwise, press the **1** key, the **ENTER** key and then using the numeric keys, enter the value for the port the printer will be connected to and then press the **ENTER** key to save the new setting and return to PRINT TABBING MENU #1. Allowable values are 0 through 3.

0 = COM0

1 = COM1

2 = COM2

3 = COM3



## CALIBRATION AND SETUP, CONT.

### 2. PRT BEG=XXXXXXXXXXXXX (PRINT BEGINNING)

With PRINT TABBING MENU #1 displayed the current setting for the PRT BEG= parameter will be shown. Note that XXXXXXXXXXXXX is the string of HEX numbers<sup>1</sup> sent to the printer before anything else. If the setting displayed is acceptable, proceed to the next setup parameter.

Otherwise, press the **2** key, the **ENTER** key and then using the alphanumeric keys, enter the new string and then press the **ENTER** key to save the new setting and return to PRINT TABBING MENU #1.

### 3. AUTO LF=XXX (AUTOMATIC LINE FEED "DATA FORMAT TERMINATION")

With PRINT TABBING MENU #1 displayed the current setting for the AUTO LF= parameter will be shown. Note that XXX is the current value. If the setting displayed is acceptable, proceed to the next setup parameter.

Otherwise, press the **3** key, the **ENTER** key, **YES** or **NO** (on the soft keys) and then the **ENTER** key to save the new setting and return to PRINT TABBING MENU #1.

### 4. ENDING LF=XX (NUMBER OF LINEFEEDS PRINTED AFTER LAST LINE)

With PRINT TABBING MENU #1 displayed the current setting for the ENDING LF= parameter will be shown. Note that XX is a pre-selected number of linefeed commands that the indicator can transmit at the end of a data transmission to a printer, to space the paper in the printer to the desired position for withdrawal or for the next print. If the setting displayed is acceptable, proceed to the next setup parameter.

Otherwise, press the **4** key, the **ENTER** key and then using the numeric keys, enter the value for the number of linefeeds to be executed after the last printed line and then press the **ENTER** key to save the new setting and return to PRINT TABBING MENU #1. Allowable values are 0 through 99.

### 5. PRT END=XXXXXXXXXXXXX (PRINT BEGINNING)

With PRINT TABBING MENU #1 displayed the current setting for the PRT END= parameter will be shown. Note that XXXXXXXXXXXXX is the string of HEX numbers<sup>1</sup> sent to the printer after the ENDING LF. If the setting displayed is acceptable, proceed to the next setup parameter.

Otherwise, press the **5** key, the **ENTER** key and then using the alphanumeric keys, enter the new string and then press the **ENTER** key to save the new setting and return to PRINT TABBING MENU #1.

<sup>1</sup> HEX numbers are always 2 digits. For example, 7 is entered as 07. The maximum entry is 6 numbers (12 characters). Valid entries are 01 through FF. Note that 00 is not valid.

# CALIBRATION AND SETUP, CONT.

## TABS SETTING (General Format Information)

The general format for the input is A = YY.XX.

Where:

A is the character identifying the data printed

YY is the number of lines down

XX is the number of spaces to the right.

**NOTE:** Enter 00 in either location, YY or XX, to disable the data from printing.

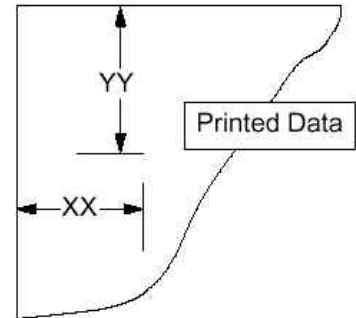

### 6. TIME=YY. XX (TIME PRINT LOCATION)

With PRINT TABBING MENU #1 displayed the current setting for the TIME= parameter will be shown. Note that YY.XX is the current position for printing of the time. If the position displayed is acceptable, proceed to the next setup parameter.

Otherwise, press the **6** key, the **ENTER** key and then using the numeric keys, enter the new print position and then press the **ENTER** key to save the new setting and return to PRINT TABBING MENU #1.

### 7. DATE=YY. XX (DATE PRINT LOCATION)

With PRINT TABBING MENU #1 displayed the current setting for the DATE= parameter will be shown. Note that YY.XX is the current position for printing of the date. If the position displayed is acceptable, proceed to the next setup parameter.

Otherwise, press the **7** key, the **ENTER** key and then using the numeric keys, enter the new print position and then press the **ENTER** key to save the new setting and return to PRINT TABBING MENU #1.

### 8. CNC NO=YY. XX (CONSECUTIVE NUMBER PRINT LOCATION)

With PRINT TABBING MENU #1 displayed the current setting for the CNC NO= parameter will be shown. Note that YY.XX is the current position for printing of the consecutive number. If the position displayed is acceptable, proceed to the next setup parameter.

Otherwise, press the **8** key, the **ENTER** key and then using the numeric keys, enter the new print position and then press the **ENTER** key to save the new setting and return to PRINT TABBING MENU #1.

## CALIBRATION AND SETUP, CONT.

### 9. GROSS=YY.XX (GROSS WEIGHT PRINT LOCATION)

With PRINT TABBING MENU #1 displayed the current setting for the GROSS= parameter will be shown. Note that YY.XX is the current position for printing of the Gross weight. If the position displayed is acceptable, proceed to the next setup parameter.

Otherwise, press the **9** key, the **ENTER** key and then using the numeric keys, enter the new print position and then press the **ENTER** key to save the new setting and return to PRINT TABBING MENU #1.

### 10. TARE=YY.XX (TARE WEIGHT PRINT LOCATION)

With PRINT TABBING MENU #1 displayed the current setting for the TARE= parameter will be shown. Note that YY.XX is the current position for printing of the Tare weight. If the position displayed is acceptable, proceed to the next setup parameter.

Otherwise, press the **1** and **0** keys, the **ENTER** key and then using the numeric keys, enter the new print position and then press the **ENTER** key to save the new setting and return to PRINT TABBING MENU #1.

With PRINT TABBING MENU #1 displayed, press **NEXT** (Navigation Keys ▾ Down Arrow) to proceed to PRINT TABBING MENU #2.

```
PRINT TABBING MENU #2
11. NET=YY.XX          16. TIME=YY.XX
12. G ACCUM=YY.XX     17. DATE=YY.XX
13. N ACCUM=YY.XX
14. COUNT=YY.XX
15. PCS WT=YY.XX
Enter Selection: 0  ▀PREV  ▀EXIT
```

### 11. NET=YY.XX (NET WEIGHT PRINT LOCATION)

With PRINT TABBING MENU #2 displayed the current setting for the NET= parameter will be shown. Note that YY.XX is the current position for printing of the Net weight. If the position displayed is acceptable, proceed to the next setup parameter.

Otherwise, press the **1** key twice, the **ENTER** key and then using the numeric keys, enter the new print position and then press the **ENTER** key to save the new setting and return to PRINT TABBING MENU #2.

## CALIBRATION AND SETUP, CONT.

### 12. G ACCUM=YY.XX (GROSS WEIGHT ACCUMULATOR PRINT LOCATION)

With PRINT TABBING MENU #2 displayed the current setting for the G ACCUM= parameter will be shown. Note that YY.XX is the current position for printing of the Gross weight accumulator. If the position displayed is acceptable, proceed to the next setup parameter.

Otherwise, press the **1** and **2** keys, the **ENTER** key and then using the numeric keys, enter the new print position and then press the **ENTER** key to save the new setting and return to PRINT TABBING MENU #2.

### 13. N ACCUM=YY.XX (NET WEIGHT ACCUMULATOR PRINT LOCATION)

With PRINT TABBING MENU #2 displayed the current setting for the N ACCUM= parameter will be shown. Note that YY.XX is the current position for printing of the Net weight accumulator. If the position displayed is acceptable, proceed to the next setup parameter.

Otherwise, press the **1** and **3** keys, the **ENTER** key and then using the numeric keys, enter the new print position and then press the **ENTER** key to save the new setting and return to PRINT TABBING MENU #2.

### 14. COUNT=YY.XX (COUNT (NUMBER OF PIECES ON SCALE) PRINT LOCATION)

With PRINT TABBING MENU #2 displayed the current setting for the COUNT= parameter will be shown. Note that YY.XX is the current position for printing of the Count (number of pieces on scale). If the position displayed is acceptable, proceed to the next setup parameter.

Otherwise, press the **1** and **4** keys, the **ENTER** key and then using the numeric keys, enter the new print position and then press the **ENTER** key to save the new setting and return to PRINT TABBING MENU #2.

### 15. PCS WT=YY.XX (PIECE WEIGHT PRINT LOCATION)

With PRINT TABBING MENU #2 displayed the current setting for the PCS WT= parameter will be shown. Note that YY.XX is the current position for printing of the Piece weight. If the position displayed is acceptable, proceed to the next setup parameter.

Otherwise, press the **1** and **5** keys, the **ENTER** key and then using the numeric keys, enter the new print position and then press the **ENTER** key to save the new setting and return to PRINT TABBING MENU #2.

## CALIBRATION AND SETUP, CONT.

### 16. CNV NET=YY.XX (CONVERTED UNITS NET WEIGHT PRINT LOCATION)



You must select LFT=NO, during Calibration and Setup to enable the Converted Units Net Weight print feature. **NOTE:** The CNV NET= weight will only print if the converted weight is greater than zero and the 225 in is the Net mode.

With PRINT TABBING MENU #2 displayed the current setting for the CNV NET= parameter will be shown. Note that YY.XX is the current position for printing of the Converted Units Net weight. If the position displayed is acceptable, proceed to the next setup parameter.

Otherwise, press the **1** and **6** keys, the **ENTER** key and then using the numeric keys, enter the new print position and then press the **ENTER** key to save the new setting and return to PRINT TABBING MENU #2.

### 17. ID=YY.XX (ID STORAGE NUMBER PRINT LOCATION)

With PRINT TABBING MENU #2 displayed the current setting for the ID= parameter will be shown. Note that YY.XX is the current position for printing of the ID Storage number. If the position displayed is acceptable, proceed to the next setup parameter.

Otherwise, press the **1** and **7** keys, the **ENTER** key and then using the numeric keys, enter the new print position and then press the **ENTER** key to save the new setting and return to PRINT TABBING MENU #2.

### Print Tabs Setting Completed

With PRINT TABBING MENU #2 displayed, press **PREV** (Navigation Keys  $\Delta$  UP Arrow) to return to PRINT TABBING MENU #1 or press **EXIT** (Navigation Keys  $\nabla$  Down Arrow) to return to SETUP MENU #2.

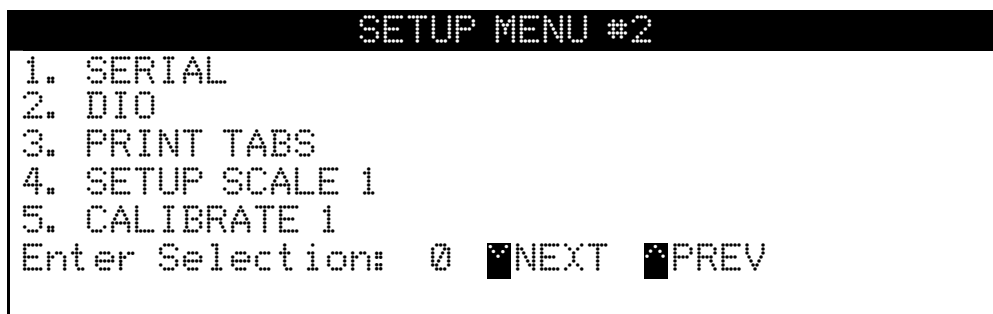

With the SETUP MENU #2 displayed,

- Proceed to the next setup parameter.
- Press **PREV** (Navigation Keys  $\Delta$  UP Arrow) to return to SETUP MENU #1.
- Press **NEXT** (Navigation Keys  $\nabla$  Down Arrow) to proceed to the SETUP MENU #3.

# CALIBRATION AND SETUP, CONT.

The following describes the Scale Setup for the 225. The standard 225 supports one (1) scale. With the optional 225-DS Dual Scale card installed, it can support up to three (3) scales. In the setup menus shown and parameters described, Scale 1 is referenced. Substitute the scale number you are configuring for the number shown.

## SETUP SCALE

With SETUP MENU #1 displayed, press **NEXT** (Navigation Keys ▾ Down Arrow) to proceed to SETUP MENU #2.

```
          SETUP MENU #2
1. SERIAL
2. DIO
3. PRINT TABS
4. SETUP SCALE 1
5. CALIBRATE 1
Enter Selection: 0  ▾NEXT ▾PREV
```

### 4. SETUP SCALE 1

With the SETUP MENU #2 displayed, press the **4** key and then the **ENTER** key to proceed to SCALE 1 SETUP MENU #1.

```
          SCALE 1 SETUP MENU #1
1. BASE UNITS=X XX    6. SAMPLES=XXX
2. CNVT UNITS=X XX   7. STABLE=XX
3. Z TRACK=X.X       8. STBL CNT=XXX
4. Z LIMIT=XXX       9. WT INTERVALS=XX
5. PWR UP Z=XXX     10. TYPE=XXXXXXXXX
Enter Selection: 0  ▾NEXT ▾EXIT
```

#### 1. BASE UNITS=X XX (BASE UNITS)

With SCALE 1 SETUP MENU #1 displayed the current setting for the **BASE UNITS=** parameter will be shown. Note that X is the current value and XX is the description. If the setting displayed is acceptable, proceed to the next setup parameter.

Otherwise, press the **1** key, the **ENTER** key and then using the numeric keys, enter the value for the base units and then press the **ENTER** key to save the new setting and return to SCALE 1 SETUP MENU #1. Allowable values are 0 through 6.

## CALIBRATION AND SETUP, CONT.

### 2. CNVT UNITS=X XX (CONVERTED UNITS)

With SCALE 1 SETUP MENU #1 displayed the current setting for the CNVT UNITS= parameter will be shown. Note that X is the current value and XX is the description. If the setting displayed is acceptable, proceed to the next setup parameter.

Otherwise, press the **2** key, the **ENTER** key and then using the numeric keys, enter the value for the converted units and then press the **ENTER** key to save the new setting and return to SCALE 1 SETUP MENU #1. Allowable values are 0 through 6.

#### BASE and CONVERTED UNITS SELECTIONS

0 = none	3 = lb (pounds)	6 = t (tonnes "metric tons")
1 = tn (tons)	4 = oz (ounces)	
2 = g (grams)	5 = kg (kilograms)	

### 3. Z TRACK=X.X (ZERO TRACKING RANGE)

With SCALE 1 SETUP MENU #1 displayed the current setting for the Z TRACK= parameter will be shown. Note that X.X is the current value. If the setting displayed is acceptable, proceed to the next setup parameter.

Otherwise, press the **3** key, the **ENTER** key and then using the numeric keys, enter the value for the zero tracking range and then press the **ENTER** key to save the new setting and return to SCALE 1 SETUP MENU #1. Allowable values are 0.0 (disables Zero Tracking), 0.5, 1.0, 2.0, 3.0, 4.0, 5.0, 6.0, 7.0, 8.0 and 9.0.

### 4. Z LIMIT=XXX (ZERO LIMIT RANGE)

With SCALE 1 SETUP MENU #1 displayed the current setting for the Z LIMIT= parameter will be shown. Note that XXX is the current value. If the setting displayed is acceptable, proceed to the next setup parameter.

Otherwise, press the **4** key, the **ENTER** key, **YES** or **NO** (on the soft keys) and then the **ENTER** key to save the new setting and return to the

Z LIMIT=YES	Z LIMIT=NO
4% ( $\pm 2\%$ ) of scale capacity	Full capacity (no limit)

### 5. PWR UP Z=XXX (POWER-UP ZERO FEATURE)

With SCALE 1 SETUP MENU #1 displayed the current setting for the PWR UP Z= parameter will be shown. Note that XXX is the current value. If the setting displayed is acceptable, proceed to the next setup parameter.

Otherwise, press the **4** key, the **ENTER** key, **YES** or **NO** (on the soft keys) and then the **ENTER** key to save the new setting and return to the

PUDO = YES	PUDO = NO
Automatic Re-Zero on Power-Up	No Re-Zero on Power-Up

## CALIBRATION AND SETUP, CONT.

### 6. SAMPLES=XXX (SAMPLE RATE)

With SCALE 1 SETUP MENU #1 displayed the current setting for the SAMPLES= parameter will be shown. Note that XXX is the current value. If the setting displayed is acceptable, proceed to the next setup parameter.

Otherwise, press the **6** key, the **ENTER** key and then using the numeric keys, enter the value for the sample rate in samples per second and then press the **ENTER** key to save the new setting and return to SCALE 1 SETUP MENU #1. Allowable values for the sample rate are 1 through 100.

### 7. STABLE=XX (STABLE "MOTION RANGE")

With SCALE 1 SETUP MENU #1 displayed the current setting for the STABLE= parameter will be shown. Note that XXX is the current value for the range of motion detection. If the setting displayed is acceptable, proceed to the next setup parameter.

Otherwise, press the **7** key, the **ENTER** key and then using the numeric keys, enter the value for the new range (the number of divisions of change permitted before indicating unstable) and then press the **ENTER** key to save the new setting and return to SCALE 1 SETUP MENU #1. Allowable values are 0 through 99 divisions.

### 8. STBL CNT=XXX (STABLE COUNT "CONSECUTIVE STABLE READINGS")

With SCALE 1 SETUP MENU #1 displayed the current setting for the STBL CNT= parameter will be shown. Note that XXX is the current number of consecutive stable weight readings before indicating stable weight. If the setting displayed is acceptable, proceed to the next setup parameter.

Otherwise, press the **8** key, the **ENTER** key and then using the numeric keys, enter the value for the stable count and then press the **ENTER** key to save the new setting and return to SCALE 1 SETUP MENU #1. Allowable values are 1 through 255.

### 9. WT INTERVAL=X (WEIGHT INTERVAL "SINGLE OR DUAL")

With SCALE 1 SETUP MENU #1 displayed the current setting for the WT INTERVAL= parameter will be shown. Note that X is the current value. If the setting displayed is acceptable, proceed to the next setup parameter.

Otherwise, press the **9** key, the **ENTER** key and then using the numeric keys, enter the value for the weight interval and then press the **ENTER** key to save the new setting and return to SCALE 1 SETUP MENU #1. Allowable values are 1 or 2.

WT INTERVAL=1

Single Interval (One weight range)

WT INTERVAL=2

Dual Interval (Two weight ranges)



## CALIBRATION AND SETUP, CONT.

### 9. WT INTERVAL=X (WEIGHT INTERVAL “SINGLE OR DUAL”), CONT.



**CAUTION!** When using the dual interval feature of the 225, do not attempt to use a division value in the low range that is too small to provide adequate signal strength for stable operation of the indicator. Most scale installations will allow the smaller division to be 1/2 of the larger division value when the dual interval feature is used.

The inherent sensitivity and capabilities of the 225 will allow you to select combinations that are beyond the practical limits of today’s load cells for dependable, stable performance. The appearance of such a situation will be instability in the lower range, while the higher range will operate, as it should.

### 10. TYPE=XXXXXXXX (SELECT SCALE TYPE)

With SCALE 1 SETUP MENU #1 displayed the current setting for the TYPE= parameter will be shown. Note that XXXXXXXX is the current value (scale type). If the setting displayed is acceptable, press **EXIT** (Navigation Keys  $\Delta$  UP Arrow) to return to the SETUP MENU #2.

Otherwise, press the **1** and **0** keys, the **ENTER** key and then using the numeric keys, enter the value for the scale type and then press the **ENTER** key to save the new setting and return to the SCALE 1 SETUP MENU #1. Allowable values are 0, 1 or 2.

0 = ANALOG

1 = GUARDIAN

2 = SERIAL

**NOTE:** To ensure proper operation, the settings in SCALE SETUP MENU #2 **MUST** match the settings of the local indicator.

With SCALE 1 SETUP MENU #1 displayed, press **NEXT** (Navigation Keys  $\nabla$  Down Arrow) to proceed to SCALE 1 SETUP MENU #2.

```
SCALE 1 SETUP MENU #2
1. FILTER=X          6. CAP=XXXXXXXX
2. FMAX=XXX
3. FBRK=XXX
4. INTERVAL=XX
5. DPP=X
Enter Selection: 0  [NEXT] [EXIT]
```



**NOTE:** Although shown on the scale setup menu, the setup parameters FMAX= and FBRK= can **only** be selected when CUSTOM FILTERING (FILTER=3) has been selected.

# CALIBRATION AND SETUP, CONT.

## 1. FILTER=X (DIGITAL FILTERING)

With SCALE 1 SETUP MENU #2 displayed the current setting for the FILTER= parameter will be shown. Note that X is the current value for the digital filtering. If the setting displayed is acceptable, proceed to the next setup parameter.

Otherwise, press the **1** key, the **ENTER** key and then using the numeric keys, enter the value for the digital filtering and then press the **ENTER** key to save the new setting and return to SCALE 1 SETUP MENU #2. Allowable values are 0, 1, 2, or 3.

- 0      DISABLED (NO Filtering)
- 1      MINIMAL FILTERING (Sample Rate = 2)
- 2      MODERATE FILTERING (Sample Rate = 1)
- 3      CUSTOM FILTERING (additional parameters available)

## 2. FMAX=XXX (MAXIMUM FILTER LEVEL)

With SCALE 1 SETUP MENU #2 displayed the current setting for the FMAX= parameter will be shown. Note that XXX is the current value for the maximum filter level. The filter level is a number from 1 to 255 that corresponds to the level of filtering with 255 being the greatest filtering and 1 the least. If the setting displayed is acceptable, proceed to the next setup parameter.

Otherwise, press the **2** key, the **ENTER** key and then using the numeric keys, enter the value for the new maximum filter level and then press the **ENTER** key to save the new setting and return to SCALE 1 SETUP MENU #2. Allowable values are 1 through 255.

## 3. FBRK=XXX (FILTER BREAK RANGE)

With SCALE 1 SETUP MENU #2 displayed the current setting for the FBRK= parameter will be shown. Note that XXX is the current value for the filter break range. The break range is a number from 1 to 255 that corresponds to the number of division changes to break out of the filtering. If the setting displayed is acceptable, proceed to the next setup parameter.

Otherwise, press the **3** key, the **ENTER** key and then using the numeric keys, enter the value for the new filter break range and then press the **ENTER** key to save the new setting and return to SCALE 1 SETUP MENU #2. Allowable values are 1 through 255.

# CALIBRATION AND SETUP, CONT.

## Filter Setting Recommendations

### Non-Critical Sample Rate

If the sample rate is not critical, as in static weighing, set FILTER= to:

- FILTER=0 (NO Filtering)
- FILTER=1 (FMAX=6, FBRK=12, SAMPLES=2/Sec) or
- FILTER=2 (FMAX=6, FBRK=8, SAMPLES=1/Sec).

### Critical Sample Rate

With a critical sample rate, as in a filling operation, use Custom Filtering (FILTER=3).

1. SAMPLES= SAMPLE RATE (1 to 200 samples/second) determination:

Set the sample rate as close as possible to produce a display graduation change for every graduation of material added to the scale.

$$\frac{\text{Material Flow Rate (lbs/second)}}{\text{Interval}} = \text{SAMPLES}$$

$$\text{EXAMPLE: } \frac{100\text{lbs/sec}}{10\text{lbs}} = 10\text{s/s} = \text{SAMPLES}$$

2. FBRK= FILTER BREAK RANGE (1 to 64 graduations) determination:

Turn the filtering off by setting FILTER=0. Operate the system as it will be normally used and, by observation, determine the number of grads of instability that needs to be filtered out. Set the break range (FBRK=) to that value.

$$\frac{\text{Weight Change}}{\text{Interval}} = \text{FBRK}$$

EXAMPLE: 20,000 x 10lb capacity scale with 800lb variation in the weight display.

$$\frac{800}{10} = \text{FBRK}=80$$

3. FMAX= MAXIMUM FILTER LEVEL (0 to 255) determination: Set to desired results.
4. If stability is unacceptable with any setting of FMAX=, reduce the sample rate and/or increase the break range, FBRK= setting for increased filtering.

## CALIBRATION AND SETUP, CONT.

### 4. INTERVAL=XX (INTERVAL SETTING)

With SCALE 1 SETUP MENU #2 displayed the current setting for the INTERVAL= parameter will be shown. Note that XX is the current value for the interval (division) setting. If the setting displayed is acceptable, proceed to the next setup parameter.

Otherwise, press the **4** key, the **ENTER** key and then using the numeric keys, enter the value for the interval and then press the **ENTER** key to save the new setting and return to SCALE 1 SETUP MENU #2.

If the 225 is used in a Legal For Trade application (LFT=YES), allowable values are 1, 2, 5, 10, 20 or 50.

If the 225 is NOT used in a Legal For Trade application (LFT=NO), allowable values are 1 through 99.

### 5. DPP=X (DECIMAL POINT POSITION)

With SCALE 1 SETUP MENU #2 displayed the current setting for the DPP= parameter will be shown. Note that X is the current value for the decimal point position. If the setting displayed is acceptable, proceed to the next setup parameter.

Otherwise, press the **5** key, the **ENTER** key and then using the numeric keys, enter the value for the decimal point position and then press the **ENTER** key to save the new setting and return to SCALE 1 SETUP MENU #2. Allowable values are 0, 1, 2, or 3.

0 = XXXXXX      1 = XXXX.X      2 = XXXX.XX      3 = XXX.XXX

### 6. CAP=XXXXXXXX (SCALE CAPACITY)

With SCALE 1 SETUP MENU #2 displayed the current setting for the CAP= parameter will be shown. Note that XXXXXXXX is the current value for the scale capacity. If the setting displayed is acceptable, proceed to the next setup parameter.

Otherwise, press the **6** key, the **ENTER** key and then using the numeric keys, enter the value for the scale capacity and then press the **ENTER** key to save the new setting and return to SCALE 1 SETUP MENU #2. Allowable values are 1 through 9,999,999. Note that the capacity cannot exceed 7 digits or 9,999,999.

## CALIBRATION AND SETUP, CONT.

### Scale 1 Setup Completed

The SCALE 1 setup has been completed, press **PREV** (Navigation Keys  $\Delta$  UP Arrow) to return to SCALE 1 SETUP MENU #1 or press **EXIT** (Navigation Keys  $\nabla$  Down Arrow) to return to the SETUP MENU #2.

```
          SETUP MENU #2
1. SERIAL
2. DIO
3. PRINT TABS
4. SETUP SCALE 1
5. CALIBRATE 1
Enter Selection: 0  █ NEXT  █ PREV
```

With the SETUP MENU #2 displayed,

- Proceed to the next setup parameter.
- Press **PREV** (Navigation Keys  $\Delta$  UP Arrow) to return to SETUP MENU #1.
- Press **NEXT** (Navigation Keys  $\nabla$  Down Arrow) to proceed to the SETUP MENU #3.

# CALIBRATION AND SETUP, CONT.

## CALIBRATE

With the SETUP MENU #1 displayed, press **NEXT** (Navigation Keys ▾ Down Arrow) to proceed to SETUP MENU #2.

```
SETUP MENU #2
1. SERIAL
2. DIO
3. PRINT TABS
4. SETUP SCALE 1
5. CALIBRATE 1
Enter Selection: 0  ▣PREV  ▣EXIT
```

### 5. CALIBRATE 1

With the SETUP MENU #2 displayed, press the **5** key and then the **ENTER** key to proceed to SCALE 1 CALIBRATION MENU.

```
SCALE 1 CALIBRATION MENU
1. Swt=XXXXXXXX      6. C1=XXX
2. Sct=XXXXXXXX      7. C2=XXX
3. Zct=XXXXXXXX      8. C3=XXX
4. FINE SPAN         9. C4=XXX
5. HI RES           10. CALIBRATE
Enter Selection: 0  ▣EXIT
```

- 1. Swt=XXXXXXXX (SPAN WEIGHT)
  - 2. Sct=XXXXXXXX (SPAN COUNT)
  - 3. Zct=XXXXXXXX (ZERO COUNT)
- } CALIBRATION PARAMETERS

The calibration parameters (Swt , Sct and Zct ) represent the test load (weight) and the analog to digital readings at zero and test load. These values are established when the scale is calibrated. By recording the parameter values, the indicator can be returned to its present calibration settings without using test weights simply by entering the values.

- 6. C1=XXX
  - 7. C2=XXX
  - 8. C3=XXX
  - 9. C4=XXX
- } CALIBRATION "C" NUMBERS

The calibration "C" numbers (C1 , C2, C3 and C4) represent the present calibration settings. Each number may be up to three digits in length. The "C" numbers are established when the scale is calibrated. By recording these numbers, the indicator can be returned to its present calibration settings without using test weights simply by entering the "C" numbers.

# CALIBRATION AND SETUP, CONT.

## CALIBRATION METHODS

The 225 has two methods to enter the calibration procedure. One method is selected from the SETUP/REVIEW MENU and the other method selected from SETUP MENU #2.

### From SETUP/REVIEW MENU:

With the SETUP/REVIEW MENU displayed, press the **3** key and then the **ENTER** key. This method proceeds directly to a display showing the settings for the capacity, interval, decimal point position and the first calibration parameter, CAL 1=0.0.

### From SETUP MENU #2:

With the SETUP MENU #2 displayed, press the **5** key and then the **ENTER** key to proceed to SCALE 1 CALIBRATION MENU. With the SCALE 1 CALIBRATION MENU displayed, press the **1** and **0** keys and then the **ENTER** key. This method will change the SCALE 1 CALIBRATION MENU to show the settings for the capacity, interval, decimal point position and the first calibration parameter, CAL 1=0.0.

## CALIBRATION MODES

The 225 indicator has seven modes that can be used to perform calibration. Four of the modes require a test load (weight), one requires the scale to be empty (and at zero) and the last two use parameter values or the calibration “C” numbers from a previous calibration. The calibration modes are as follows:

### 1. Multi-Point

This method requires two weights, an empty scale and has two conversion factors. It uses three calibration points, CAL 1=, CAL 2= and CAL 3=. The three points correspond to zero weight, mid-point weight and test load (weight) and can be applied in any order.

### 2. Dual-Point with Zero (First Zero)

This is a standard calibration method requiring one weight, an empty scale and has one conversion factor. This method uses two calibration points (CAL 1= and CAL 2=) to establish a zero (no load) calibration value and to span the indicator. The two points correspond to zero weight and test load (weight) and can be applied in any order. This method should be used for first-time calibration and complete recalibration.

### 3. Dual-Point without Zero (False Zero)

This calibration method requires one test weight and establishes a new conversion factor only. It is used to establish a false (temporary zero) zero without affecting the zero calibration value stored during the last calibration. This is particularly useful in tank weighing applications, where it may be impractical or impossible to completely empty the tank. This method uses two calibration points, CAL 1= and CAL 2=. The value of the test load (weight) is entered when CAL 1= is displayed and then the **NET/GROSS** key pressed when CAL 2= is displayed.

## CALIBRATION AND SETUP, CONT.

### 4. Single-Point for Span Only (Last Zero)

This calibration method requires one test weight, the scale at zero and establishes a new conversion factor (span) without affecting the zero calibration value stored during the last calibration. This minimizes placing and removing test loads (weights) and is especially useful when checking high capacity scales. This method uses two calibration points, CAL 1= and CAL 2=. The value of the test load (weight) is entered when CAL 1= is displayed and then the **ZERO** key pressed when CAL 2= is displayed.

### 5. Single-Point for Zero Only (Only Zero)

This calibration method requires no test weight, an empty scale and establishes a new zero without affecting the conversion factor (span). This is useful to regain the full range of zero limit when the dead load of the scale has changed. This would occur for example, if a guardrail has been added to the scale platform. This method uses two calibration points, CAL 1= and CAL 2=. The **ENTER** key is pressed when CAL 1= is displayed and then the **ZERO** key pressed when CAL 2= is displayed.

### 6. Calibration Parameters (Swt, Zct and Sct)

The calibration parameters represent the test load weight Swt = (Span Weight) and the analog to digital readings at zero Zct = (Zero Count) and test load Sct = (Span Count). These values are established when the scale is calibrated. They are useful when replacing an indicator (or if the need arises to re-calibrate the scale) and a test load (weights) are not available. By entering the previously recorded parameter values, the indicator can be returned to its present calibration setting without using test load (weights).

### 7. Calibration "C" Numbers

The calibration "C" numbers (C1=, C2=, C3= and C4=) are displayed on the SCALE 1 CALIBRATION MENU during the calibration and setup procedure. These numbers correspond to the calibration setting of the indicator. They can be used when replacing an indicator (or if the need arises to recalibrate the scale) and test load (weights) are not available. By entering the previously recorded numbers, the indicator can be returned to its present calibration settings without using test load (weights).



# CALIBRATION AND SETUP, CONT.

## Multi-Point Calibration

### CAL 1= (FIRST CALIBRATION WEIGHT)

With the SCALE 1 CALIBRATION MENU displayed, press the **1** and **0** keys and then the **ENTER** key. The display will change to show the settings for capacity, interval, decimal point position and CAL 1=0.0. This is the first of three calibration weights. It could be ZERO (no load), the MID-POINT weight or the TEST load (weight).

1. If the first calibration weight is to be ZERO (no load), press the **ENTER** key. The display will flash CALIBRATING. . . for a few seconds and then change to show CAL 2=.
2. If the first calibration weight is to be the MID-POINT weight or the TEST load (weight), place the weights on the scale.
3. Using the numeric keys, enter the value of the TEST load (weight) and then press the **ENTER** key.
4. The display will flash CALIBRATING. . . for a few seconds and then change to show CAL 2=.

### CAL 2= (SECOND CALIBRATION WEIGHT)

The display will show CAL 2=XXXXXXXX. This is the second of three calibration weights. It could be ZERO (no load), the MID-POINT weight or the TEST load (weight).

1. If the second calibration weight is to be ZERO (no load), press the **0** key and then the **ENTER** key. The display will flash CALIBRATING. . . for a few seconds and then change to show CAL 3=.
2. If the second calibration weight is to be the MID-POINT weight or the TEST load (weight), place the weights on the scale.
3. Using the numeric keys, enter the value of the test load (weight) and then press the **ENTER** key.
4. The display will flash CALIBRATING. . . for a few seconds and then change to show CAL 3=.

### CAL 3= (LAST CALIBRATION WEIGHT)

The display will show CAL 3=XXXXXXXX. This is the last of three calibration weights. It could be ZERO (no load), the MID-POINT weight or the TEST load (weight).

1. If using 3 point calibration and the last calibration weight is to be ZERO (no load), press the **0** key and then the **ENTER** key. The display will change to show the SCALE 1 CALIBRATION MENU.
2. If using 3-point calibration and the last calibration weight is to be the MID-POINT weight or the TEST load (weight), place the weights on the scale.
3. Using the numeric keys, enter the value of the test load (weight) and then press the **ENTER** key.
4. The display will flash CALIBRATING. . . for a few seconds and then change to show the SCALE 1 CALIBRATION MENU. **NOTE:** If Span Adjustment is required, proceed to the FINE SPAN ADJUSTMENT on page 70.

# CALIBRATION AND SETUP, CONT.

## Dual-Point with Zero (First Zero) Calibration

### CAL 1= (FIRST CALIBRATION WEIGHT)

With the SCALE 1 CALIBRATION MENU displayed, press the **1** and **0** keys and then the **ENTER** key. The display will change to show the settings for capacity, interval, decimal point position and CAL 1=0.0. This is the first of two calibration weights. It could be ZERO (no load) or the TEST load (weight).

1. If the first calibration weight is to be ZERO (no load), press the **ENTER** key. The display will flash CALIBRATING. . . for a few seconds and then change to show CAL 2=.
2. If the first calibration weight is to be the TEST load (weight), place the weights on the scale.
3. Using the numeric keys, enter the value of the TEST load (weight) and then press the **ENTER** key.
4. The display will flash CALIBRATING. . . for a few seconds and then change to show CAL 2=.

### CAL 2= (SECOND CALIBRATION WEIGHT)

The display will show CAL 2=XXXXXXXX. This is the second of two calibration weights. It could be ZERO (no load) or the TEST load (weight).

1. If the second calibration weight is to be ZERO (no load), press the **0** key and then the **ENTER** key. The display will flash CALIBRATING. . . for a few seconds and then change to show CAL 3=.
2. If the second calibration weight is to be the TEST load (weight), place the weights on the scale.
3. Using the numeric keys, enter the value of the test load (weight) and then press the **ENTER** key.
4. The display will flash CALIBRATING. . . for a few seconds and then change to show CAL 3=.

### CAL 3= (LAST CALIBRATION WEIGHT)

The display will show CAL 3=. This weight is not used. Press the **ENTER** key to skip CAL 3=. The display will change to show the SCALE 1 CALIBRATION MENU. **NOTE:** If Span Adjustment is required, proceed to the FINE SPAN ADJUSTMENT on page 70.

# CALIBRATION AND SETUP, CONT.

## Dual-Point without Zero (False Zero) Calibration

### CAL 1= (FIRST CALIBRATION WEIGHT)

With the SCALE 1 CALIBRATION MENU displayed, press the **1** and **0** keys and then the **ENTER** key. The display will change to show the settings for capacity, interval, decimal point position and CAL 1=0.0. This is the first of two calibration steps. This weight is the TEST load (weight).

1. Place the weights on the scale.
2. Using the numeric keys, enter the value of the TEST load (weight) and then press the **ENTER** key.
3. The display will flash CALIBRATING. . . for a few seconds and then change to show CAL 2=.

### CAL 2= (SECOND CALIBRATION WEIGHT)

The display will show CAL 2=XXXXXXXX. This is the second of two calibration steps.

1. Remove the weights on the scale, and then press the **NET/GROSS** key.
2. The display will change to show the SCALE 1 CALIBRATION MENU. **NOTE:** If Span Adjustment is required, proceed to the FINE SPAN ADJUSTMENT on page 70.

## Single-Point for Span Only (Last Zero) Calibration

### CAL 1= (FIRST CALIBRATION WEIGHT)

With the SCALE 1 CALIBRATION MENU displayed, press the **1** and **0** keys and then the **ENTER** key. The display will change to show the settings for capacity, interval, decimal point position and CAL 1=0.0. This is the first of two calibration steps. This weight is the TEST load (weight).

1. Zero the scale, and then place the weights on the scale.
2. Using the numeric keys, enter the value of the TEST load (weight) and then press the **ENTER** key.
3. The display will flash CALIBRATING. . . for a few seconds and then change to show CAL 2=.

### CAL 2= (SECOND CALIBRATION WEIGHT)

The display will show CAL 2=XXXXXXXX. This is the second of two calibration steps.

1. Remove the weights on the scale, and then press the **NET/GROSS** key.
2. The display will change to show the SCALE 1 CALIBRATION MENU. **NOTE:** If Span Adjustment is required, proceed to the FINE SPAN ADJUSTMENT on page 70.

## CALIBRATION AND SETUP, CONT.

### Single-Point for Zero Only (Only Zero) Calibration

#### CAL 1= (FIRST CALIBRATION WEIGHT)

With the SCALE 1 CALIBRATION MENU displayed, press the **1** and **0** keys and then the **ENTER** key. The display will change to show the settings for capacity, interval, decimal point position and CAL 1=0.0. This is the first of two calibration steps.

1. Insure the scale is empty and then press the **ENTER** key.
2. The display will flash CALIBRATING. . . for a few seconds and then change to show CAL 2=.

#### CAL 2= (SECOND CALIBRATION WEIGHT)

The display will show CAL 2=XXXXXXXX. This is the second of two calibration steps.

1. Press the **ZERO** key.
2. The display will change to show the SCALE 1 CALIBRATION MENU. **NOTE:** If Span Adjustment is required, proceed to the FINE SPAN ADJUSTMENT on page 70.

# CALIBRATION AND SETUP, CONT.

## Fine Span Adjustment

### 4. FINE SPAN (FINE SPAN ADJUSTMENT)

If Fine Span Adjustment is desired, place a calibrated test weight on the scale and with the SCALE 1 CALIBRATION MENU displayed, press the **4** key and then the **ENTER** key. The display will change to show SCALE 1 FINE SPAN ADJUST. Note that **ADJ = XXXXXXXX** is the current displayed weight.



- Press **UP** (Navigation Keys ▲ UP Arrow) to increase the span.
- Press **DOWN** (Navigation Keys ▼ Down Arrow) to decrease the span.
- Press **EXIT** (Navigation Keys ◀ Left Arrow) to save the new setting and return to the SCALE 1 CALIBRATION MENU.

### 5. HI RES (HIGH RESOLUTION ADJUSTMENT)

If High Resolution Weight adjustment is desired, place a calibrated test weight on the scale and with the SCALE 1 CALIBRATION MENU displayed, press the **5** key and then the **ENTER** key. The display will change to show SCALE 1 HIRES ADJUSTMENT. Note that **HIRES=XXXXXX** is the active weight in “high resolution” mode (in 1/10 interval).

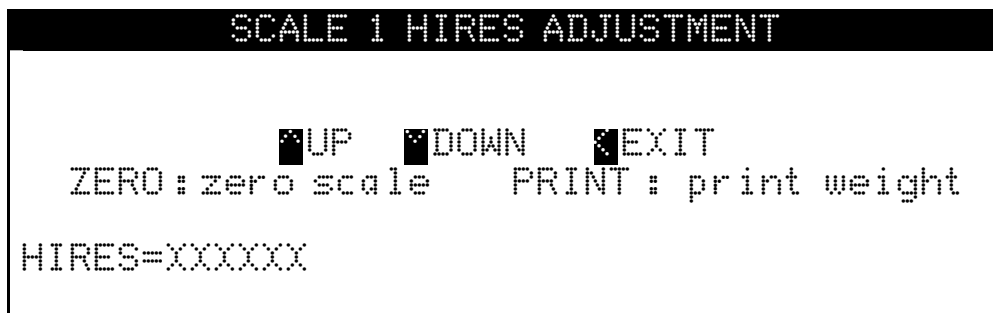

- Press **UP** (Navigation Keys ▲ UP Arrow) to increase the span.
- Press **DOWN** (Navigation Keys ▼ Down Arrow) to decrease the span.
- Press **EXIT** (Navigation Keys ◀ Left Arrow) to save the new setting and return to the SCALE 1 CALIBRATION MENU.
- Press the **ZERO** key to zero the scale.
- Press the **PRINT** key to print the weight (followed by the text TEST).

# CALIBRATION AND SETUP, CONT.

## Calibration Parameters

The calibration parameters (`Swt`, `Sct` and `Zct`) represent the test load (weight) and the analog to digital readings at zero and test load. These values are established when the scale is calibrated. To return the indicator to its present calibration settings (without using test weights) enter the calibration parameters values.

### 1. `Swt=XXXXXXXX` (SPAN WEIGHT)

With the SCALE 1 CALIBRATION MENU displayed the current setting for the `Swt` parameter will be shown. Note that `XXXXXXXX` is the current value for the calibrated test load Span weight. If the setting displayed is acceptable, proceed to the next setup parameter.

Otherwise, press the **1** key, the **ENTER** key and then using the numeric keys, enter the value for the calibrated test load Span weight and then press the **ENTER** key to save the new setting and return to the SCALE 1 CALIBRATION MENU. Allowable values are 1 through 9,999,999. Note that the capacity cannot exceed 7 digits or 9,999,999.

### 2. `Sct=XXXXXXXX` (SPAN COUNT)

With the SCALE 1 CALIBRATION MENU displayed the current setting for the `Sct` parameter will be shown. Note that `XXXXXXXX` is the current value for the analog to digital reading at test load Span count. If the setting displayed is acceptable, proceed to the next setup parameter.

Otherwise, press the **2** key, the **ENTER** key and then using the numeric keys, enter the value for the test load Span count and then press the **ENTER** key to save the new setting and return to the SCALE 1 CALIBRATION MENU. Allowable values are 1 through 9,999,999. Note that the capacity cannot exceed 7 digits or 9,999,999.

### 3. `Zct=XXXXXXXX` (ZERO COUNT)

With the SCALE 1 CALIBRATION MENU displayed the current setting for the `Zct` parameter will be shown. Note that `XXXXXXXX` is the current value for the analog to digital reading at zero, the Zero count. If the setting displayed is acceptable, proceed to the next setup parameter.

Otherwise, press the **3** key, the **ENTER** key and then using the numeric keys, enter the value for the zero load Zero count and then press the **ENTER** key to save the new setting and return to the SCALE 1 CALIBRATION MENU. Allowable values are 1 through 9,999,999. Note that the capacity cannot exceed 7 digits or 9,999,999.

# CALIBRATION AND SETUP, CONT.

## Calibration “C” Numbers

The calibration “C” numbers (C1, C2, C3 and C4) represent the present calibration settings. Each number may be up to three (3) digits in length. These values are established when the scale is calibrated. To return the indicator to its present calibration settings (without using test weights) enter the calibration “C” numbers.

```
6. C1=XXX
7. C2=XXX
8. C3=XXX
9. C4=XXX
```

    } CALIBRATION “C” NUMBERS

With the SCALE 1 CALIBRATION MENU displayed the current setting for the C1=, C2=, C3= and C4= parameters will be shown. Note that XXX is the current value for the calibration “C” number. If the settings displayed match the numbers recorded previously, proceed to the next setup parameter.

Otherwise, press the **6**, **7**, **8** or **9** key, (for the “C” number to be changed), the **ENTER** key and then using the numeric keys, enter the value for the “C” number and then press the **ENTER** key to save the new setting and return to the SCALE 1 CALIBRATION MENU. Allowable values are 1 through 255.



**If any components have been changed that affect calibration and/or the scale is used in a commercial application and must be "Legal for Trade", calibration parameters or the “C” numbers cannot be use to re-calibrate.**

## Scale 1 Calibration Completed

The SCALE 1 calibration has been completed, press **EXIT** (Navigation Keys  $\Delta$  UP Arrow) to return to SETUP MENU #2.

```
SETUP MENU #2
1. SERIAL
2. DIO
3. PRINT TABS
4. SETUP SCALE 1
5. CALIBRATE 1
Enter Selection: 0  ▾NEXT  ▸PREV
```

With the SETUP MENU #2 displayed,

- Press **PREV** (Navigation Keys  $\Delta$  UP Arrow) to return to SETUP MENU #1.
- Press **NEXT** (Navigation Keys  $\nabla$  Down Arrow) to proceed to the SETUP MENU #3.

# CALIBRATION AND SETUP, CONT.

## SETUP MENU #3

With SETUP MENU #2 displayed, press **NEXT** (Navigation Keys ▾ Down Arrow) to proceed to SETUP MENU #3.

```
SETUP MENU #3
1. G/N ACCUMS=XXX      6. KEY LOCKOUT
2. BACK LITE= X        7. LRPort=COM3
3. PASSWORD
4. 2XX-
5. BADGE RDR
Enter Selection: 0  ▣PREV  ▣EXIT
```

## ACCUMULATORS

### 1. G/N ACCUMS (GROSS/NET ACCUMULATORS)

With the SETUP MENU #3 displayed the current setting for the G/N ACCUMS= parameter will be shown. Note that XXX is the current value. If the setting displayed is acceptable, proceed to the next setup parameter.

Otherwise, press the **1** key, the **ENTER** key, **YES** or **NO** (on the soft keys) and then the **ENTER** key to save the new setting and return to the SETUP MENU #3.

```
G/N ACCUMS=YES
Gross and Net Accumulators
are Enabled
```

```
G/N ACCUMS=NO
Gross and Net Accumulators
are Disabled
```

## BACK LIGHT

### 2. BACK LITE (BACKLIGHT TURN-ON LEVEL)

With the SETUP MENU #3 displayed the current setting for the BACK LITE= parameter will be shown. Note that XX is the current value. If the setting displayed is acceptable, proceed to the next setup parameter.

Otherwise, press the **2** key and then the **ENTER** key. The display will change to show the current light level (Lights= XX).

```
SETUP MENU #3

Lights= XX

BACK LITE = XX
```



## CALIBRATION AND SETUP, CONT.

Using the numeric keys, enter the value for the new backlight turn-on level and then press the **ENTER** key to save the new setting and return to SETUP MENU #3. Allowable values are 0 through 99.

**NOTE:** The value selected must be less than the Light  $\leq$  value to activate.

BACK LITE=0

Backlight always ON

BACK LITE=99

Backlight always OFF

BACK LITE=XX

Level that backlight  
turns ON at

### PASSWORD

#### 3. PASSWORD (PASSWORD)

The password setup parameter determines whether a password is required to enter Calibration and Setup on indicators programmed for international use (USA=NO). If the indicator is programmed for domestic use (USA=YES) the password parameter WILL NOT be displayed on SETUP MENU #3.

With the SETUP MENU #3 displayed press the **3** key and then the **ENTER** key. The display will change to show PASSWORD=XXXXXXXXXXXX. Note that XXXXXXXXXXXX is the current password if a password was previously entered, otherwise only PASSWORD= will be displayed.

If the setting displayed is acceptable, proceed to the next setup parameter. Otherwise, using the alphanumeric keys, enter up to 12 characters for the password and then press the **ENTER** key to save the new setting and return to the SETUP MENU #3.

### PASSWORD OPERATION

With a **PASSWORD** set, anytime the operator tries to enter Calibration and Setup, the display will show the PASSWORD= prompt requiring the operator to enter the correct password. If the wrong password is entered, the indicator displays **ERROR** momentarily and returns to the weight mode. Note that the password is not shown on the display when the operator is entering it.



**NOTE:** It is recommended to write the password down and store it in a secure location. If the password is forgotten or lost and a change to the indicator setup is required, the indicator must be reprogrammed. **WARNING!** Reprogramming the indicator will **ERASE ALL** the contents of the Nov-Ram and memory.

### 2XX- OPTION CARDS

#### 4. 2XX- (2XX OPTION CARD)

This prompt will ONLY be displayed when a 2XX Option Card is installed in the indicator. Refer to the manual for the 2XX option card installed for setup instructions.

# CALIBRATION AND SETUP, CONT.

## BADGE READER

### 5. BADGE RDR (BADGE READER)

The badge reader setup parameter determines the port used by the badge reader, the type of badge reader used and the weight needed on the scale (threshold weight) before the badge reader will work.

With the SETUP MENU #3 displayed press the **5** key and then the **ENTER** key. The display will change to show the **BADGE READER SETUP Menu**.

```
BADGE READER SETUP Menu
1. PORT=2      COM2
2. TYPE=1      AWID
3. THRES WT = 1500
4. SITE ID = XXX (Only displayed if Type=1, AWID)

Enter Selection: 0      [F4]EXIT
```

#### 1. Port= (BADGE READER PORT)

With the BADGE READER SETUP Menu displayed the current setting for the Port = parameter will be shown. This is the serial port the indicator will use for the Badge Reader. If the setting displayed is acceptable, proceed to the next setup parameter.

Otherwise, press the **1** key, the **ENTER** key and then using the numeric keys, enter the value for the serial port the indicator will use for the Badge Reader and then press the **ENTER** key to save the new setting and return to the BADGE READER SETUP Menu. Allowable values are 1, 2 or 3.

1 = COM1                      2 = COM2                      3=COM3

#### 2. TYPE=X XXXXXXXXXXXX (TYPE OF BADGE READER)

With the BADGE READER SETUP Menu displayed the current setting for the TYPE= parameter will be shown. Note that X is the current value and XXXXXXXXXXXX is the description. If the setting displayed is acceptable, proceed to the next setup parameter.

Otherwise, press the **2** key, the **ENTER** key and then using the numeric keys, enter the value for the type of badge reader and then press the **ENTER** key to save the new setting and return to the BADGE READER SETUP Menu. Allowable values are 0 through 5.

0 = NONE                      2 = SMARTPASS                      4 = MAGS (MAGSTRIP)  
1 = AWID (See Note)                      3 = HID                      5 = FLEXPASS

**NOTE:** If you selected 1 = AWID for the TYPE= parameter, the setup parameter 4. SITE ID= will be shown on the BADGE READER SETUP Menu.

## CALIBRATION AND SETUP, CONT.

### 3. Thres Wt =XXXXXXXX (THRESHOLD WEIGHT FOR BADGE READER)

With the BADGE READER SETUP Menu displayed the current setting for the Thres Wt = parameter will be shown. Note that XXXXXXXX is the current value. If the setting displayed is acceptable, press **EXIT** (Navigation Keys  $\Delta$  UP Arrow) to return to the Serial Menu.

Otherwise, press the **3** key, the **ENTER** key and then using the numeric keys, enter the value for the threshold weight used to allow the badge reader to work and then press the **ENTER** key to save the new setting and return to the BADGE READER SETUP Menu.

**If you selected 1 = AWID for the TYPE= parameter on the BADGE READER SETUP Menu, the following setup parameter will be shown.**

### 4. SITE ID= (SITE ID REQUIRED)

With the BADGE READER SETUP Menu displayed (and TYPE=1 (AWID) set) the current setting for the SITE ID= parameter will be shown. Note that XXX is the current value. If the setting displayed is acceptable, proceed to the next setup parameter.

Otherwise, press the **1** key, the **ENTER** key, **YES** or **NO** (on the soft keys) and then the **ENTER** key to save the new setting and return to the BADGE READER SETUP Menu.

SITE ID=YES

Badges must have 3-digit Site ID to be valid

SITE ID=NO

Badge Reader will work without Site ID on badges

# CALIBRATION AND SETUP, CONT.

## KEY LOCKOUT

### 6. KEY LOCKOUT (KEY LOCKOUT)

The key lockout parameter determines which keys are locked during normal operation. Pressing a locked key during normal operation will result in a warning beep, a 1/2 second display of `-LOCKED-` and the key will be ignored.

With the SETUP MENU #3 displayed press the **6** key and then the **ENTER** key. The display will change to show the Key LOCKOUT Menu.

```
Key LOCKOUT Menu
1. ZERO=NO      6. UNITS=NO    11. GREEN=NO
2. TARE=NO      7. ACCUM=NO
3. NET=NO       8. KEYPAD=NO
4. PRINT=NO     9. ID=NO
4. TIME=NO     10. COUNT=NO
Enter Selection: 0
```

1. The display will change to show the 11 keys that can be locked and the current status for each key.
2. If the status of each key displayed is acceptable, press the **ENTER** key to exit and return to SETUP MENU #3.
3. Otherwise, to change the lockout status of a key, use the numeric keys to select the key to change and then press the **ENTER** key.
4. The display will change to show Lockout `XXXXXX? XXX` and turn on the **YES** and **NO** soft keys. Note that `XXXXXX` is the key and `XXX` is the current lockout status.

```
Key LOCKOUT Menu
1. ZERO=NO      6. UNITS=NO    11. GREEN=NO
2. TARE=NO      7. ACCUM=NO
3. NET=NO       8. KEYPAD=NO
4. PRINT=NO     9. ID=NO
4. TIME=NO     10. COUNT=NO
Lockout XXXXXX? XXX
YES                                                    NO
```

5. Press the **YES** or **NO** (on the soft keys) and then the **ENTER** key to save the new setting and return to the Key LOCKOUT Menu.
6. Continue with this procedure until the status of each key has been entered.
7. After the last key lockout status has been entered, press the **ENTER** key to exit and return to SETUP MENU #3.

# CALIBRATION AND SETUP, CONT.

## LOCAL REMOTE PORT



**NOTE:** Although shown on this example of SETUP MENU #3, the setup parameter LRPort = will **only** be displayed when TYPE=SERIAL has been selected in SCALE 1 SETUP MENU #1.

```
SETUP MENU #3
1. G/N ACCUMS=XXX      6. KEY LOCKOUT
2. BACK LITE= X       7. LRPort=COM3
3. PASSWORD
4. 2XX-
5. BADGE RDR
Enter Selection: 0  ▀PREV  ▀EXIT
```

### 7. LRPort = (LOCAL REMOTE PORT)

With the SETUP MENU #3 displayed the current setting for the LRPort = parameter will be shown. This is the serial port the indicator will use for the Local/Remote connection. Note that COM3 is the current port shown. This is the system default port. If the setting displayed is acceptable, press **EXIT** (Navigation Keys ▾ Down Arrow) to return to the SETUP/REVIEW MENU.

Otherwise, press the **7** key, the **ENTER** key and then using the numeric keys, enter the value for the serial port the indicator will use for the Local/Remote port and then press the **ENTER** key to save the new setting and return to the SETUP MENU #3. Allowable values are 1, 2 or 3. **NOTE:** 3=COM3 is the default setting.

```
SETUP MENU #3
Select Local-Remote Port
1=COM1   2=COM2   3=COM3

LR Port=3
```

With the SETUP MENU #3 displayed,

- Press **PREV** (Navigation Keys △ UP Arrow) to return to SETUP MENU #2.
- Press **EXIT** (Navigation Keys ▾ Down Arrow) to return to the SETUP/REVIEW MENU.

# ID STORAGE SETUP

## Mode of Operation = 1 (ID Storage)

With SETUP MENU #1 displayed the current setting for the 10. MODE OF OP= parameter will be shown. Press the **1** and **0** keys and then the **ENTER** key. The display will change to show the Mode Of Operation Menu. Press the **1** key and then the **ENTER** key to select ID Storage. The display will change to show the ID Storage Menu below.

```

ID Storage Menu
1. WT ALARM=XXX      3. PROMPT 1=XXXXXXXXXXXXX
2. ID COUNT=X       4. PROMPT 2=XXXXXXXXXXXXX
                    5. PROMPT 3=XXXXXXXXXXXXX
Enter Selection: 0  [ ]EXIT

```

\*

### 1. WT ALARM (WEIGHT ALARM)

With the ID Storage Menu displayed the current setting for the WT ALARM= parameter will be shown. Note that XXX is the current value. The WT ALARM will energize relay #1 for a selected time when the weight on the scale exceeds a threshold weight. If the setting displayed is acceptable, proceed to the next setup parameter.

Otherwise, press the **1** key, the **ENTER** key, **YES** or **NO** (on the soft keys) and then the **ENTER** key to save the new setting and return to the ID Storage Menu.

WT ALARM = YES  
Weight Alarm is ON

WT ALARM = NO  
Weight Alarm is OFF

### 2. ID COUNT (NUMBER OF ID PROMPTS, Categories)

With the ID Storage Menu displayed the current setting for the ID COUNT= parameter will be shown. Note that X is the current value. These categories will be displayed when the ID key is pressed. For example, in order to track the truck and trailer, two prompts (categories) would be needed. If the setting displayed is acceptable, proceed to the next setup parameter.

Otherwise, press the **2** key, the **ENTER** key and then using the numeric keys, enter the value for the printer parity rate and then press the **ENTER** key to save the new setting and return to the ID Storage Menu. Allowable values are 1, 2 or 3.

ID COUNT=1  
One Prompt

ID COUNT=2  
Two Prompts

ID COUNT=3  
Three Prompts

\* The value selected for ID COUNT will determine the number of additional prompts (PROMPT X=) displayed on the ID Storage Menu.

## ID STORAGE SETUP, CONT.

### 3. PROMPT 1= (PROMPT 1 NAME)

With the ID Storage Menu displayed the current setting for the PROMPT 1= parameter will be shown. Note that XXXXXXXXXXXXX is the current name. If the setting displayed is acceptable, proceed to the next setup parameter.

Otherwise, press the **3** key, the **ENTER** key and then using the alphanumeric keys, enter up to 12 characters to refer to the first prompt and then press the **ENTER** key to save the new setting and return to the ID Storage Menu.

### 4. PROMPT 2= (PROMPT 2 NAME)

With the ID Storage Menu displayed the current setting for the PROMPT 2= parameter will be shown. Note that XXXXXXXXXXXXX is the current name. If the setting displayed is acceptable, proceed to the next setup parameter.

Otherwise, press the **4** key, the **ENTER** key and then using the alphanumeric keys, enter up to 12 characters to refer to the second prompt and then press the **ENTER** key to save the new setting and return to the ID Storage Menu.

### 5. PROMPT 3= (PROMPT 3 NAME)

With the ID Storage Menu displayed the current setting for the PROMPT 3= parameter will be shown. Note that XXXXXXXXXXXXX is the current name. If the setting displayed is acceptable, proceed to the next setup parameter.

Otherwise, press the **5** key, the **ENTER** key and then using the alphanumeric keys, enter up to 12 characters to refer to the third prompt and then press the **ENTER** key to save the new setting and return to the ID Storage Menu.

## ID Storage Setup Completed

1. With the ID Storage Menu displayed, press **EXIT** (Navigation Keys  $\Delta$  UP Arrow) to return to the Mode Of Operation Menu.
2. With the Mode Of Operation Menu displayed, press **EXIT** (Navigation Keys  $\Delta$  UP Arrow) to return to the SETUP MENU #1.
3. Press **NEXT** (Navigation Keys  $\nabla$  Down Arrow) to proceed to the SETUP MENU #2.
4. Press **EXIT** (Navigation Keys  $\Delta$  UP Arrow) to return to the SETUP/REVIEW MENU.
5. Press **EXIT** (Navigation Keys  $\Delta$  UP Arrow) to reset the indicator and return to normal operations.

# PRESET WEIGHT COMPARATORS SETUP

## Mode of Operation = 3 (Preset Weight Comp)

With SETUP MENU #1 displayed the current setting for the 10. MODE OF OP= parameter will be shown. Press the **1** and **0** keys and then the **ENTER** key. The display will change to show the Mode Of Operation Menu. Press the **3** key and then the **ENTER** key to select Preset Weight Comp. The display will change to show the Preset Weight Comparator Menu below.

```
          Preset Weight Comparator Menu
1. OUTPUTS=XX
2. BAL PRNT=XXX

Enter Selection: 0  █EXIT
```

### 1. OUTPUTS (NUMBER OF PRESET WEIGHT COMPARATORS “PWC”)

With the Preset Weight Comparator Menu displayed the current setting for the OUTPUTS= parameter will be shown. Note that XX is the current value. If the setting displayed is acceptable, proceed to the next setup parameter.

Otherwise, press the **1** key, the **ENTER** key and then using the numeric keys, enter the value for the number of PWC outputs and then press the **ENTER** key to save the new setting and return to the Preset Weight Comparator Menu. Allowable values are 1 through 16.

The output state of each PWC before reaching the preset weight is set in the DIO SETUP MENU. Refer to the DIO SETUP (PWC Status) section of the CALIBRATION AND SETUP section of this manual.



The relay state is based on using Cardinal Scale relays (p/n 6850-1013). If using relays other than those supplied by Cardinal Scale, refer to the relay manufacturers specifications.

**NOTE:** When power to the 225 is lost, the output returns to a Low State condition.



## PRESET WEIGHT COMPARATORS SETUP, CONT.

### 2. BAL PRNT (AUTOMATIC PRINT ON BALANCE)

With the Preset Weight Comparator Menu displayed the current setting for the BAL PRNT= parameter will be shown. Note that XXX is the current value.



**NOTE:** The automatic print on balance feature may be enabled only when one PWC is selected (OUTPUTS=1). If more than one PWC has been selected, this feature is disabled.

If the Automatic Print on Balance is enabled, when the weight equals the preset value and all motion on the scale stops, the weight will be printed (if a printer is attached). Note that the weight must go below 50% of the preset value before another print operation can be performed.

If the setting displayed is acceptable, proceed to the next setup parameter. Otherwise, press the **2** key, the **ENTER** key, **YES** or **NO** (on the soft keys) and then the **ENTER** key to save the new setting and return to the Preset Weight Comparator Menu.

BAL PRNT=YES

Automatic Print Enabled

BAL PRNT=NO

Automatic Print Disabled

### Preset Weight Comparators Setup Completed

1. With the Preset Weight Comparator Menu displayed, press **EXIT** (Navigation Keys  $\Delta$  UP Arrow) to return to the Mode Of Operation Menu.
2. With the Mode Of Operation Menu displayed, press **EXIT** (Navigation Keys  $\Delta$  UP Arrow) to return to the SETUP MENU #1.
3. Press **NEXT** (Navigation Keys  $\nabla$  Down Arrow) to proceed to the SETUP MENU #2.
4. Press **EXIT** (Navigation Keys  $\Delta$  UP Arrow) to return to the SETUP/REVIEW MENU.
5. Press **EXIT** (Navigation Keys  $\Delta$  UP Arrow) to reset the indicator and return to normal operations.

# COUNT OPERATION

## Counting



You must select **LFT=NO**, during Setup and Calibration to enable the **COUNT** key and Counting functions.

## Sampling and Counting

1. With the indicator in the Gross Weight mode (G on the display), press the **COUNT** key. The display will show **ADD 5 PCS** if no previous sample has been taken or **COUNT=** if a sample has previously been taken.
2. If **ADD 5 PCS** is displayed, proceed to step 4.
3. If **COUNT=** is displayed, press the **COUNT** key again to change the display to show **ADD 5 PCS** then continue to step 4.
4. If needed, press the **COUNT** key again to step to the next sample quantity. Continue pressing the **COUNT** key until the desired value is displayed.

Note, that pressing the **COUNT/SAMPLE** key repeatedly will cause the sample quantity to step in the following sequence: 5, 10, 25, 50, 75, 5, 10, etc.

5. When the displayed value (for the sample size) is acceptable, press the **ENTER** key.
6. Otherwise, use the numeric keys to enter a new value (for the sample size) and then press the **ENTER** key to save it and proceed with the counting operation.
7. Add the indicated sample quantity and press the **ENTER** key.
8. Add the pieces to be counted and read total the count
9. Press the **NET/GROSS** key to complete the counting operation and return to normal operation.

## Counting Out From a Container

1. Place the filled container on the scale platform and press the **TARE** key.
2. The display will show zero weight and **NET** to indicate the weight is Net weight.
3. Press the **COUNT** key.
4. Remove a sample piece from the container and press the **ENTER** key.
5. Remove the pieces from the container and read the total number removed.
6. Press the **NET/GROSS** key to complete the counting operation and return to normal operation.

## NOTES

- As the need for counting accuracy increases, the size of the sample must also increase.
- As individual uniformity of the parts decrease, the sample size must increase.
- Manual counting errors may occur if samples larger than necessary are used.
- Because of variation of individual container weights, be certain to "tare off" each container by placing the empty container on the scale and pressing the **ZERO** key before proceeding with the count operation.

# ID STORAGE OPERATION

The ID Storage feature has been designed to control three different types of transactions and weighing operations. The first type of transaction assigns a permanent ID string, has a stored tare weight, and accumulates net weight totals for the ID. The second type assigns a permanent ID string and accumulates net weight totals for the ID, but does not have a permanent stored weight. The third type temporarily assigns an ID string (while weighing in) and does not accumulate any net weight totals for the ID.

## PERMANENT

### Single Pass Transaction (One-Step Operation)

The first type of permanent transaction is a "single pass" transaction and is used to weigh loaded containers with a permanent ID string and a previously stored tare weight. The stored tare weight requires weighing the empty container in advance or if the weight of the empty container is known, by entering that value as a manual tare weight. The single pass transaction completes a ticket and accumulates the net weight for the ID associated with the container with a "one-step" weighing operation.

### Two Pass Transaction (Two Step Operation)

The second type of permanent transaction is a "two pass" transaction and is used to weigh the loaded container once when it is empty and once when it is loaded. A permanent ID string and a previously stored zero (0) tare weight is required. In the two pass transaction, the zero tare weight is replaced by the new tare weight after the first pass and returned to zero after the second pass when the transaction has been completed. The two pass transaction requires a "two-step" weighing operation. On the first step, the incoming weight will be stored and an interim ticket will be printed. On the second step, during the outgoing transaction, a complete ticket will be printed and the net weight for the ID associated with the container will be added to the accumulator.

## TEMPORARY

### Two Pass Transaction (Two Step Operation)

The third type is a temporary "two pass" transaction that also requires a "two-step" operation. However, the ID string is only in memory while the container is weighed in and out and the net weight will not be accumulated. In this type of transaction, on the first pass, the container will be placed on the scale and an ID will be selected either by the operator entering an ID string or by the indicator automatically assigning the ID string. The weight will be stored and an interim ticket will be printed. On the second pass, the ID string is entered and the stored weight is recalled for printing the complete ticket. After the ticket has printed, the ID number and the stored weight will be removed from memory.

## ID STORAGE OPERATION, CONT.

### Gross Weight Alarm

If `WT ALARM = YES` was selected in the ID Storage Menu setup, the indicator will display and activate a **PRESET** soft key. By using the **PRESET** key, a gross weight can be programmed to turn on the PWC1 control output for a programmed time (1-99 seconds) when the gross weight exceeds the programmed weight.

`ALARM WT (PWC 1) =XXXXXX`

To program the alarm gross weight and alarm on time, press the **PRESET** key. The display will show `ALARM WT (PWC 1) =XXXXXX`. Using the numeric keys, enter the desired alarm gross weight and press the **ENTER** key. The preset weight will be stored and the display will change to show the alarm `TIME ON=X` parameter.



**IMPORTANT! The gross weight must fall below 1/2 the preset weight before the alarm is re-armed.**

`TIME ON=X`

Using the numeric keys, enter the desired alarm `TIME ON=X` value (1-99 seconds) and press the **ENTER** key. The on time will be stored and the display will return to normal mode. Note that setting `TIME ON=0` disables the alarm.

## ID STORAGE OPERATION, CONT.

The following describes the ID Storage operation for the 225 with the ID Count set for one prompt. Therefore, only one prompt name is referenced. Substitute the prompt name entered during ID Storage Setup for the prompt name shown. Note that with the ID Count set for more than one prompt, additional steps will be displayed.

### Permanent Identification (ID) Strings

#### To Add A Permanent ID String

1. With the indicator in normal operations mode, press the **MEM** key. The display will change to show **Id=**.
2. Enter up to a 12-digit alphanumeric ID string and press the **ENTER** key.
3. The display will show **Ref =**.
4. Using the alphanumeric keys enter up to 12 characters for the name and then press the **ENTER** key.
5. The display will change to show a zero tare weight value stored.
6. If a zero tare weight is correct, press the **ENTER** key and proceed to the next step. Otherwise, using the numeric keys, enter the tare weight and then press the **ENTER** key or to use the current scale weight for the tare, press the **GROSS** key and then the **ENTER** key.
7. The display will change to show a zero value for the accumulator associated with the ID string.
8. If a zero value is correct, press the **ENTER** key to save it. Otherwise, using the numeric keys, enter the accumulator value and then press the **ENTER** key to save it.
9. The indicator will return to normal operation.

#### To Edit or View A Permanent ID String

1. With the indicator in normal operations mode, press the **MEM** key. The display will change to show **Id=**.
2. Enter the ID string and press the **ENTER** key.
3. The display will show **Ref =XXXXXXXXXXXX**. Note that XXXXXXXXXXXXXXX is the name associated with the ID.
4. If the name displayed is acceptable, press the **ENTER** key to save it. Otherwise, using the alphanumeric keys enter up to 12 characters for the name and then press the **ENTER** key.
5. The display will change to show the current tare weight stored.
6. If the displayed tare weight is correct, press the **ENTER** key and proceed to the next step. Otherwise, using the numeric keys, enter the correct tare weight and then press the **ENTER** key or to use the current scale weight for the tare, press the **GROSS** key and then the **ENTER** key.
7. The display will change to show the accumulator value of the ID entered. **NOTE:** If the accumulator value is greater than (>) 999,999,999, **OVERFLOW** will be displayed
8. If the displayed value is correct, press the **ENTER** key to save it. Otherwise, using the numeric keys, enter the correct value and then press the **ENTER** key to save it.
9. The indicator will return to normal operation.

# ID STORAGE OPERATION, CONT.

## Permanent Identification (ID) Strings, Cont.

### To Delete A Permanent ID String

1. With the indicator in normal operations mode, press the **MEM** key. The display will change to show `Id=`.
2. Enter the ID string to be deleted and then press the **DELETE** key.
3. The display will show `Id deleted` momentarily.
4. The ID string entered along with its associated accumulator will be deleted.
5. The indicator will return to normal operation.

### To Print A Permanent ID String

1. With the indicator in normal operations mode, press the **MEM** key. The display will change to show `Id=`.
2. Enter the ID string and then press the **PRINT** key.
3. A ticket containing the stored weight, the accumulated weight along with the ID string will be printed and the indicator will return to normal operation.
4. If the ID string entered does not exist, the display will show `ID NOT FOUND` and then indicator will return to normal operation.

### To Delete All Permanent ID Strings

1. With the indicator in normal operations mode, press the **MEM** key. The display will change to show `Id=`.
2. Press the **DELETE** key. The display will show `Del All?NO`, which asks if all ID strings are to be deleted.
3. To delete all ID strings, press the **YES** key (display will change to `Del All?YES`) and then press the **ENTER** key.
4. All ID strings and the associated accumulators will be deleted.
5. The indicator will return to normal operation.

### To Print All ID Strings:

1. With the indicator in normal operations mode, press the **MEM** key. The display will change to show `Id=`.
2. Press the **PRINT** key. The display will show `Printing` while all currently stored ID strings are printed.
3. The indicator will return to normal operation.

# ID STORAGE OPERATION, CONT.

## PERMANENT ID

### Single Pass Transaction (One-Step Operation)

The single pass transaction (one-step operation) is used to weigh LOADED containers with a permanent ID string and a *previously stored tare weight* associated with that ID string. This requires weighing the empty container in advance or if the empty weight is known, by entering that value as a manual tare weight when adding the permanent ID.

### Single ID (Loaded Container With One ID Prompt)

1. With the indicator in normal operations mode, place the loaded container on the scale
2. Press the **ID** key. The display will change to show **ID1=** (the Prompt 1 name entered in ID Storage Setup).
3. Enter up to a 12-digit alphanumeric ID string and press the **ENTER** key.
4. The display will momentarily show **Ref=** (and the name associated with the ID) then change to **Print Pass 2** before returning to the Gross weight display.
5. The Net weight will be added to the accumulator of the entered ID string and the ticket printed will show the TIME, DATE, ID, TIME/DATE of Stored Tare weight, the Gross, Tare, and Net weights.

### Multiple IDs (Loaded Container With Two ID Prompts)

1. With the indicator in normal operations mode, place the loaded container on the scale
2. Press the **ID** key. The display will change to show **ID1=** (the Prompt 1 name entered in ID Storage Setup).
3. Enter up to a 12-digit alphanumeric ID string and press the **ENTER** key.
4. The display will momentarily show **Ref=** (and the name associated with the ID) then change to **ID2=** (the Prompt 2 name entered in ID Storage Setup).
  - If only one ID prompt is needed, press the **PRINT** key to store the weight and print the ticket. Proceed to Step 7.
5. If two ID prompts are required, enter up to a 12-digit alphanumeric string for the second ID prompt.
6. Press the **PRINT** or **ENTER** key to store the tare weight and print the ticket.
7. The indicator will print a ticket; display **Print Pass 2** before returning to the Gross weight display.
8. The Net weight will be added to the accumulator of the entered ID string and the ticket printed will show the TIME, DATE, ID, TIME/DATE of Stored Tare weight, the Gross, Tare, and Net weights.

# ID STORAGE OPERATION, CONT.

## PERMANENT ID

### Single Pass Transaction (One-Step Operation)

#### Multiple IDs (Loaded Container With Three ID Prompts)

1. With the indicator in normal operations mode, place the loaded container on the scale
2. Press the **ID** key. The display will change to show **ID1=** (the Prompt 1 name entered in ID Storage Setup).
3. Enter up to a 12-digit alphanumeric ID string and press the **ENTER** key.
4. The display will momentarily show **Ref =** (and the name associated with the ID) then change to **ID2=** (the Prompt 2 name entered in ID Storage Setup).
  - If only one ID prompt is needed, press the **PRINT** key to store the weight and print the ticket. Proceed to Step 9.
5. If two ID prompts are required, enter up to a 12-digit alphanumeric string for the second ID prompt.
  - If only two ID prompts are needed, press the **PRINT** key to store the weight and print the ticket. Proceed to Step 9.
  - If three ID prompts are required press the **ENTER** key to proceed to the third prompt.
6. The display will show **ID3=** (the Prompt 3 name entered in ID Storage Setup).
7. Enter up to a 12-digit alphanumeric string for the third ID prompt.
8. Press the **PRINT** or **ENTER** key to store the tare weight and print the ticket.
9. The indicator will print a ticket; display **Print Pass 2** before returning to the Gross weight display.
10. The Net weight will be added to the accumulator of the entered ID string and the ticket printed will show the TIME, DATE, ID, TIME/DATE of Stored Tare weight, the Gross, Tare, and Net weights.



# ID STORAGE OPERATION, CONT.

## PERMANENT ID

### Two Pass Transaction (Two-Step Operation)

The two pass transaction is a two-step operation used to weigh the container once when it is empty and once when it is loaded. A permanent ID string and a *previously stored zero tare* weight associated with that ID string is required.

In the two pass transaction, the zero tare weight will be replaced by the new tare weight after the first pass and the stored weight will return to zero after the second pass.

On the first step, the incoming weight will be stored and an interim ticket will be printed. On the second step, during the outgoing transaction, a complete ticket will be generated and the net weight will be added to the permanent ID string accumulator.

### Single ID (Empty or Loaded Container With One ID Prompt)

#### Step 1

1. With the indicator in normal operations mode, place the loaded container on the scale
2. Press the **ID** key. The display will change to show `ID1=` (the Prompt 1 name entered in ID Storage Setup).
3. Enter up to a 12-digit alphanumeric ID string and press the **ENTER** key.
  - If a ticket is desired, press the **PRINT** key to store the weight and print the ticket. The display will show `Print Pass 1`. Proceed to Step 4.
  - If a ticket is NOT desired, press the **ENTER** key to store the weight. Proceed to Step 4.
4. The display will momentarily show `Ref =` (and the name associated with the ID) then return to the Gross weight display.

#### Step 2

1. With the indicator in normal operations mode, place the loaded container on the scale
2. Press the **ID** key. The display will change to show `ID1=` (the Prompt 1 name entered in ID Storage Setup).
3. Enter up to a 12-digit alphanumeric ID string and press the **PRINT** key.
4. The indicator will print a ticket; display `Print Pass 2` before returning to the Gross weight display.
5. The Net weight will be added to the accumulator of the entered ID string and the ticket printed will show the TIME, DATE, ID, TIME/DATE of Stored Tare weight, the Gross, Tare, and Net weights.

# ID STORAGE OPERATION, CONT.

## PERMANENT ID

### Two Pass Transaction (Two-Step Operation), Cont.

#### MULTIPLE IDs (Empty or Loaded Container With Two ID Prompts)

##### Step 1

1. With the indicator in normal operations mode, place the loaded container on the scale
2. Press the **ID** key. The display will change to show `ID1=` (the Prompt 1 name entered in ID Storage Setup).
3. Enter up to a 12-digit alphanumeric ID string and press the **ENTER** key.
4. The display will momentarily show `Ref =` (and the name associated with the ID) then change to `ID2=` (the Prompt 2 name entered in ID Storage Setup).
  - If only one ID prompt is needed AND a ticket is desired, press the **PRINT** key to store the weight and print the ticket. The display will show `Print Pass 1`. Proceed to Step 6.
5. If two ID prompts are required, enter up to a 12-digit alphanumeric string for the second ID prompt.
  - If only two ID prompts are needed AND a ticket is desired, press the **PRINT** key to store the weight and print the ticket. The display will show `Print Pass 1`. Proceed to Step 6.
  - If a ticket is NOT desired, press the **ENTER** key to store the weight. Proceed to Step 6.
6. The indicator will return to the Gross weight display.

##### Step 2

1. With the indicator in normal operations mode, place the loaded container on the scale
2. Press the **ID** key. The display will change to show `ID1=` (the Prompt 1 name entered in ID Storage Setup).
3. Enter up to a 12-digit alphanumeric ID string and press the **PRINT** key.
4. The indicator will print a ticket; display `Print Pass 2` before returning to the Gross weight display.
5. The Net weight will be added to the accumulator of the entered ID string and the ticket printed will show the TIME, DATE, ID, TIME/DATE of Stored Tare weight, the Gross, Tare, and Net weights.

# ID STORAGE OPERATION, CONT.

## PERMANENT ID

### Two Pass Transaction (Two-Step Operation), Cont.

### MULTIPLE IDs (Empty or Loaded Container With Three ID Prompts)

#### Step 1

1. With the indicator in normal operations mode, place the loaded container on the scale
2. Press the **ID** key. The display will change to show `ID1=` (the Prompt 1 name entered in ID Storage Setup).
3. Enter up to a 12-digit alphanumeric ID string and press the **ENTER** key.
4. The display will momentarily show `Ref =` (and the name associated with the ID) then change to `ID2=` (the Prompt 2 name entered in ID Storage Setup).
  - If only one ID prompt is needed AND a ticket is desired, press the **PRINT** key to store the weight and print the ticket. The display will show `Print Pass 1`. Proceed to Step 8.
5. If two ID prompts are required, enter up to a 12-digit alphanumeric string for the second ID prompt.
  - If only two ID prompts are needed AND a ticket is desired, press the **PRINT** key to store the weight and print the ticket. The display will show `Print Pass 1`. Proceed to Step 8.
  - If three ID prompts are required press the **ENTER** key to proceed to the third prompt.
6. The display will show `ID3=` (the Prompt 3 name entered in ID Storage Setup).
7. Enter up to a 12-digit alphanumeric string for the third ID prompt.
  - If a ticket is desired, press the **PRINT** key to store the weight and print the ticket. The display will show `Print Pass 1`. Proceed to Step 8.
  - If a ticket is NOT desired, press the **ENTER** key to store the weight. Proceed to Step 8.
8. The indicator will return to the Gross weight display.

#### Step 2 - Empty or Loaded Container

1. With the indicator in normal operations mode, place the loaded container on the scale
2. Press the **ID** key. The display will change to show `ID1=` (the Prompt 1 name entered in ID Storage Setup).
3. Enter up to a 12-digit alphanumeric ID string and press the **PRINT** key.
4. The indicator will print a ticket; display `Print Pass 2` before returning to the Gross weight display.
5. The Net weight will be added to the accumulator of the entered ID string and the ticket printed will show the TIME, DATE, ID, TIME/DATE of Stored Tare weight, the Gross, Tare, and Net weights.

# ID STORAGE OPERATION, CONT.

## TEMPORARY ID

### Two Pass Transaction (Two-Step Operation)



**NOTE:** If the ID string entered already exists, the display will show `ID IN USE` momentarily and the indicator will return to normal operation.

### Single ID (Store A Temporary ID String and Print A Ticket with One ID Prompt)

#### First Pass

1. With the indicator in normal operations mode, press the **ID** key.
2. The display will change to show `ID1=`.
3. Enter up to a 12-digit alphanumeric ID string and press the **PRINT** key. *If a ticket is NOT desired, press the **ENTER** key instead.*
4. The indicator will store the current scale weight under this ID string, print a ticket and display `Print Pass 1`.

#### Second Pass

1. With the indicator in normal operations mode, press the **ID** key.
2. The display will change to show `ID1=`.
3. Enter up to a 12-digit alphanumeric ID string and press the **PRINT** key.
4. The indicator will print a ticket, display `Print Pass 2`, and delete the ID string.

### Multiple IDs (Store A Temporary ID String and Print A Ticket with Two ID Prompts)

#### First Pass

1. With the indicator in normal operations mode, press the **ID** key.
2. The display will change to show `ID1=`.
3. Enter up to a 12-digit alphanumeric ID string and press the **ENTER** key.
4. The display will change to show `ID2=`.
5. Enter up to a 12-digit alphanumeric ID string and press the **PRINT** key. *If a ticket is NOT desired, press the **ENTER** key instead.*
6. The indicator will store the current scale weight under this ID string, print a ticket and display `Print Pass 1`.

#### Second Pass

1. With the indicator in normal operations mode, press the **ID** key.
2. The display will change to show `ID1=`.
3. Enter up to a 12-digit alphanumeric ID string and press the **PRINT** key.
4. The indicator will print a ticket, display `Print Pass 2`, and delete the ID string.

# ID STORAGE OPERATION, CONT.

## TEMPORARY ID

### Multiple IDs (Store A Temporary ID String and Print A Ticket with Three ID Prompts)

#### First Pass

1. With the indicator in normal operations mode, press the **ID** key.
2. The display will change to show `ID1=`.
3. Enter up to a 12-digit alphanumeric ID string and press the **ENTER** key.
4. The display will change to show `ID2=`.
5. Enter up to a 12-digit alphanumeric ID string and press the **ENTER** key.
6. The display will change to show `ID3=`.
7. Enter up to a 12-digit alphanumeric ID string and press the **PRINT** key. *If a ticket is NOT desired, press the **ENTER** key instead.*
8. The indicator will store the current scale weight under this ID string, print a ticket and display `Print Pass 1`.

#### Second Pass

1. With the indicator in normal operations mode, press the **ID** key.
2. The display will change to show `ID1=`.
3. Enter up to a 12-digit alphanumeric ID string and press the **PRINT** key.
4. The indicator will print a ticket, display `Print Pass 2`, and delete the ID string.

# ID STORAGE OPERATION, CONT.

## TEMPORARY ID

### Automatically Assign A Temporary ID String (One ID Prompt)

#### First Pass

1. With the indicator in normal operations mode, press the **ID** key.
2. The display will change to show ID1=.
3. Press the **PRINT** key. *If a ticket is NOT desired, press the **ENTER** key instead.*
4. A temporary ID string will be assigned and the weight stored.
5. A temporary ticket showing the ID string and weight will be printed and the display will show Print Pass 1.

#### Second Pass

1. With the indicator in normal operations mode, press the **ID** key.
2. The display will change to show ID1=.
3. Enter the ID string printed on the ticket and then press the **PRINT** key.
4. The indicator will print a ticket, display Print Pass 2, and delete the ID string.

### Multiple IDs (Temporary ID String with Two ID Prompts)

#### First ID Automatically Assigned, Second ID Manually Entered

#### First Pass

1. With the indicator in normal operations mode, press the **ID** key.
2. The display will change to show ID1=.
3. Press the **ENTER** key.
4. The display will change to show ID2=.
5. Enter up to a 12-digit alphanumeric ID string and press the **PRINT** key. *If a ticket is NOT desired, press the **ENTER** key instead.*
6. The automatically assigned temporary ID string, the manually entered ID, and the weight will be stored.
7. A temporary ticket showing the ID strings and weight will be printed and the display will show Print Pass 1.

#### Second Pass

1. With the indicator in normal operations mode, press the **ID** key.
2. The display will change to show ID1=.
3. Enter the ID string printed on the ticket and then press the **PRINT** key.
4. The indicator will print a ticket, display Print Pass 2, and delete the ID string.

# ID STORAGE OPERATION, CONT.

## TEMPORARY ID

### Multiple IDs (Temporary ID String with Three ID Prompts)

#### First ID Automatically Assigned, Second and Third IDs Manually Entered

##### First Pass

1. With the indicator in normal operations mode, press the **ID** key.
2. The display will change to show `ID1=`.
3. Press the **ENTER** key.
4. The display will change to show `ID2=`.
5. Enter up to a 12-digit alphanumeric ID string and press the **ENTER** key.
6. The display will change to show `ID3=`.
7. Enter up to a 12-digit alphanumeric ID string and press the **PRINT** key. *If a ticket is NOT desired, press the **ENTER** key instead.*
8. Temporary ID strings will be assigned and the weight stored.
9. A temporary ticket showing the ID strings and weight will be printed and the display will show `Print Pass 1`.

##### Second Pass

1. With the indicator in normal operations mode, press the **ID** key.
2. The display will change to show `ID1=`.
3. Enter the ID string printed on the ticket and then press the **PRINT** key.
4. The indicator will print a ticket, display `Print Pass 2`, and delete the ID string.

# PRESET WEIGHT COMPARATORS OPERATION

The Model 225 indicator has sixteen (16) outputs, which can be configured during the setup of the weight indicator to perform as Preset Weight Comparators “PWC”. If the PWC feature was selected during setup, the indicator will compare each enabled preset weight value with the displayed weight and then output a signal for each preset based on the comparison results.

## Enter Preset Values

With the indicator in normal operations mode, press the **PRESET** key.

1. P=XXXXXX	7. P=XXXXXX	13. P=XXXXXX
2. P=XXXXXX	8. P=XXXXXX	14. P=XXXXXX
3. P=XXXXXX	9. P=XXXXXX	15. P=XXXXXX
4. P=XXXXXX	10. P=XXXXXX	16. P=XXXXXX
5. P=XXXXXX	11. P=XXXXXX	17. SET TRIM
6. P=XXXXXX	12. P=XXXXXX	18. SET SCALE
ENTER PWC# TO CHANGE: 0		
PRESET	TRIM	SCALE
		EXIT

### 1. P=XXXXXX (PRESET 1 WEIGHT VALUE)

through

### 16. P=XXXXXX (PRESET 16 WEIGHT VALUE)

1. The display will change to show the values for the enabled PWCs. Note that XXXXXX is the current value for each preset.

**NOTE:** In the example shown above, all 16 preset values are shown enabled.

2. If the values displayed for each preset are acceptable, press the **ENTER** key to exit and return to normal operation.
3. Otherwise, to change a preset weight value, use the numeric keys to select the PWC# (1 to 16) to change and then press the **ENTER** key. The display will change to show the current value (PWC #= XXXXXX) of the preset selected.
4. Using the numeric keys, enter the new value for the preset and then press the **ENTER** key to save the new setting.
5. Continue with this procedure until a value for each preset to be used has been entered.
6. After the last preset value has been entered, press the **TRIM** soft key to enter the preset trim weight values or press the **ENTER** key to exit and return to normal operation.

**NOTE:** Enter a zero (0) then press the **ENTER** key if the preset weight comparator is not to be used.



# PRESET WEIGHT COMPARATORS OPERATION

## 17. SET TRIM (SET TRIM WEIGHT)

1. With the display showing the values of the enabled PWCs, press the **1** and **7** keys and then the **ENTER** key.

1. T=	0	7. T=	0	13. T=	0
2. T=	0	8. T=	0	14. T=	0
3. T=	0	9. T=	0	15. T=	0
4. T=	0	10. T=	0	16. T=	0
5. T=	0	11. T=	0	17. SET WGT	
6. T=	0	12. T=	0	18. SET SCALE	
ENTER PWC# TO CHANGE: 0					
PRESET		TRIM		SCALE	EXIT

2. The display will change to show the values of the enabled PWCs preset trim weights. Note that 0 is the factory default value for each preset.
3. If the values displayed for each preset trim weight are acceptable, press the **ENTER** key to exit and return to normal operation.
4. Otherwise, use the numeric key to select the PWC# (1 to 16) trim weight to change and then press the **ENTER** key. The display will change to show the current trim weight value (TRM #= X) of the preset selected.
5. Using the numeric keys, enter the new value for the preset trim weight and then press the **ENTER** key to save the new setting.
6. Continue with this procedure until a value for each preset trim weight to be used has been entered.
7. After the last preset trim value has been entered, press the **1** and **8** keys and then the **ENTER** key to enter the preset scale values or press the **ENTER** key to exit and return to normal operation.

Remember that the trim weight is to compensate for material in transit and causes the preset to turn on when the displayed weight equals or exceeds the Preset weight value LESS its associated Trim weight value. Also, remember that the preset is based on the displayed weight, which can be either gross or net weight.

# PRESET WEIGHT COMPARATORS OPERATION

## 18. SET SCALE (SET SCALE)

1. With the display showing the values of the enabled PWCs presets or trim weights, press the **SCALE** soft key.

```
1. S=X      7. S=X      13. S=X
2. S=X      8. S=X      14. S=X
3. S=X      9. S=X      15. S=X
4. S=X     10. S=X      16. S=X
5. S=X     11. S=X      17. SET TRIM
6. S=X     12. S=X      18. SET SCALE
ENTER PWC# TO CHANGE: 0
PRESET      TRIM      SCALE      EXIT
```

2. The display will change to show the scale that each enabled PWC is associated with. Note that X is the current value for each preset.
3. If the values displayed for each preset are acceptable, press the **ENTER** key to exit and return to normal operation.
4. Otherwise, use the numeric key to select the PWC# (1 to 16) scale association to change and then press the **ENTER** key. The display will change to show the current scale association (SCL # = X) of the preset selected.
5. Using the numeric keys, enter the new value for the preset scale association and then press the **ENTER** key to save the new setting.
6. Continue with this procedure until a value for each preset scale association to be used has been entered.
7. After the last preset scale associated has been entered, press the **ENTER** key to exit and return to normal operation.

**NOTE:** To select the TOTAL scale, enter a 4 at the SCL # = prompt.

## Enter Preset Values Completed

After entry of the presets, trim weight and scale associations are complete, operation may begin. Press the **ENTER** key to exit and return to normal operation. Note that the Preset Weight Comparators are always active unless a zero preset value was entered for the preset.



**IMPORTANT!** Remember that the preset weight comparators function operates on the absolute value of the weight ignoring the polarity.

# ACCUMULATORS

## Net Weight Accumulator

### To VIEW and PRINT the Net Weight accumulator:

1. With the indicator in normal operations mode, press the **ACCUM** key. The display will change to show `ACCUMULATOR=.`
2. Press the **NET/GROSS** key. The display will change to show the Net Weight accumulator value.
3. Press the **PRINT** key. The value for the Net Weight accumulator will be printed.
4. Press the **ENTER** key or **ESC** (press **SHIFT** and then `←`) key to exit and return to normal operation.

### To ZERO the Net Weight accumulator:

1. With the indicator in normal operations mode, press the **ACCUM** key. The display will change to show `ACCUMULATOR=.`
2. Press the **NET/GROSS** key. The display will change to show the Net Weight accumulator value.
3. Press the **ZERO** or `←` (**BACKSPACE**) key.
4. The value for the Net Weight accumulator will be reset to zero.
5. Press the **ENTER** key or **ESC** (press **SHIFT** and then `←`) key to exit and return to normal operation.

## Gross Weight Accumulator

### To VIEW and PRINT the Gross Weight accumulator:

1. With the indicator in normal operations mode, press the **ACCUM** key. The display will change to show `ACCUMULATOR=.`
2. Press the **NET/GROSS** key twice. The display will change to show the Gross Weight accumulator value.
3. Press the **PRINT** key. The value for the Gross Weight accumulator will be printed.
4. Press the **NET/GROSS** key, **ENTER** key or **ESC** (press **SHIFT** and then `←`) key to exit and return to normal operation.

### To ZERO the Gross Weight accumulator:

1. With the indicator in normal operations mode, press the **ACCUM** key. The display will change to show `ACCUMULATOR=.`
2. Press the **NET/GROSS** key twice. The display will change to show the Gross Weight accumulator value.
3. Press the **ZERO** or `←` (**BACKSPACE**) key.
4. The Gross Weight accumulator will be reset to zero.
5. Press the **NET/GROSS** key, **ENTER** key or **ESC** (press **SHIFT** and then `←`) key to exit and return to normal operation.

# ACCUMULATORS, CONT.

## Count Accumulators

### To view the **COUNT** accumulator:

1. Press the **ACCUM** key. The display will change to show `ACCUMULATOR=`.
2. Press the **COUNT** key.
3. The display will change to show the Piece Count Accumulator value.
4. Press the **ENTER** key to return to normal operation.

### To print the **COUNT** accumulator:

1. Press the **ACCUM** key. The display will change to show `ACCUMULATOR=`.
2. Press the **COUNT** key.
3. The display will change to show the Piece Count Accumulator value.
4. Press the **PRINT** key.
5. The value for the Piece Count accumulator will be printed.
6. Press the **ENTER** key.
7. The indicator will return to normal operation when printing has been completed.

### To zero the **COUNT** accumulator:

1. Press the **ACCUM** key. The display will change to show `ACCUMULATOR=`.
2. Press the **COUNT** key.
3. The display will change to show the Piece Count Accumulator value.
4. Press the **ZERO** key.
5. The value for the Piece Weight accumulator will be reset to zero.
5. Press the **ENTER** key to return to normal operation.

# ACCUMULATORS, CONT.

## ID Accumulators

### To View An ID Accumulator:

1. With the indicator in normal operations mode, press the **ACCUM** key. The display will change to show `ACCUMULATOR=`.
2. Press the **ID** key. The display will change to show `Id=`.
3. Enter the ID string and press the **ENTER** key.
4. The display will show `Ref =XXXXXXXXXXXXXX`. Note that `XXXXXXXXXXXXXX` is the name associated with the ID.
5. Press the **ENTER** key.
6. The display will change to show the current tare weight stored.
7. Press the **ENTER** key.
8. The display will change to show the accumulator value of the ID entered or if the accumulator value is greater than (>) 999,999,999, `OVERFLOW` will be displayed.
9. Press the **ENTER** key to return to normal operation.

### To Print A Single ID Accumulator:

1. With the indicator in normal operations mode, press the **ACCUM** key. The display will change to show `ACCUMULATOR=`.
2. Press the **ID** key. The display will change to show `Id=`.
3. Enter the ID string and press the **ENTER** key.
4. The display will show `Ref =XXXXXXXXXXXXXX`. Note that `XXXXXXXXXXXXXX` is the name associated with the ID.
5. Press the **ENTER** key.
6. The display will change to show the current tare weight stored.
7. Press the **ENTER** key.
8. The display will change to show the accumulator value of the ID entered or if the accumulator value is greater than (>) 999,999,999, `OVERFLOW` will be displayed.
9. Press the **PRINT** key. The accumulator value for the ID entered will be printed.
10. The indicator will return to normal operation when printing has been completed.

### To Print All Active ID Accumulators:

1. With the indicator in normal operations mode, press the **ACCUM** key. The display will change to show `ACCUMULATOR=`.
2. Press the **ID** key. The display will change to show `Id=`.
3. Press the **PRINT** key.
4. The display will show `Printing`.
5. The accumulator values for ALL active IDs will be printed.
6. The indicator will return to normal operation when printing has been completed.

## ACCUMULATORS, CONT.

### To Zero A Single ID Accumulator:

1. With the indicator in normal operations mode, press the **ACCUM** key. The display will change to show `ACCUMULATOR=`.
2. Press the **ID** key. The display will change to show `Id=`.
3. Enter the ID string and press the **ENTER** key.
4. The display will show `Ref =XXXXXXXXXXXXXX`. Note that `XXXXXXXXXXXXXX` is the name associated with the ID.
5. Press the **ENTER** key.
6. The display will change to show the current tare weight stored.
7. Press the **ENTER** key.
8. The display will change to show the accumulator value of the ID entered or if the accumulator value is greater than (>) 999,999,999, `OVERFLOW` will be displayed.
9. Press the **ZERO** key.
10. The accumulator value for the ID entered will be reset to zero.
11. Press the **ENTER** key to return to normal operation.

### To Zero All Active ID Accumulators:

1. With the indicator in normal operations mode, press the **ACCUM** key. The display will change to show `ACCUMULATOR=`.
2. Press the **ID** key. The display will change to show `Id=`.
3. Press the **DELETE** key.
4. The display will show `Del All?NO`, which asks if all active ID accumulators are to be deleted.
5. To delete all active ID accumulators, press the **YES** key.
6. The display will change to `Del All?YES`.
7. Press the **ENTER** key.
8. The accumulator values for ALL active IDs will be reset to zero.
9. The indicator will return to normal operation when all active IDs have been zeroed.

# CONTINUOUS OUTPUT FORMATS

## SMA – (Type=0)

<lf><s><r><n><m><f><xxxxxx.xxx><uuu><cr>

Where:

lf =	Line Feed	
s =	Flags	Z= center of Zero, O = Over cap, E = zero Error, e = weight not currently being displayed
r =	Range	1, 2, 3, ...
n =	Mode	G = Gross, T = Tare, N = Net
m =	Motion	M = Motion, " " ( <i>blank</i> ) = no motion
f =	Custom	Custom flag
xxxxxx.xxx =	Weight	Six digits with decimal point
uuu =	Units	ton, lb, oz, t, kg, g
cr =	Carriage Return	(hex 0D)

## SB-400 – (Type=1)

<s><xxxxxx><d><uu><m><cc><cr>

Where:

s =	Sign	"-" = negative, " " ( <i>blank</i> ) = positive
xxxxxx.xxx =	Weight	Six digits
d =	Decimal point	Added to string if enabled in setup
uu =	Units	tn, lb, oz, t, kg, g
m =	Mode	G = Gross, N = Net
cc =	Weight Status	OC = over capacity CZ = center of zero MO = motion ee = weight not currently being displayed
cr =	Carriage Return	(hex 0D)

# CONTINUOUS OUTPUT FORMATS, CONT.

## TOLEDO – (Type=2)

### Format 0 – 8530 no CKSUM

<stx><swa><swb><swc>xxxxxx>yyyyyy<cr>

Where:

stx =	Start of TeXt (hex 02)
swa =, swb=, swc=	Status Bytes
xxxxxx=	Displayed Weight, Gross or Net Weight (Six Digits)
yyyyyy=	Tare Weight (Six Digits)
cr =	Carriage Return (hex 0D)

### Format 1 – SHORT no CKSUM

<stx><swa><swb><swc>xxxxxx<cr>

Where:

stx =	Start of TeXt (hex 02)
swa =, swb=, swc=	Status Bytes
xxxxxx=	Displayed Weight, Gross or Net Weight (Six Digits)
cr =	Carriage Return (hex 0D)

### Format 2 – 8530 with CKSUM

<stx><swa><swb><swc>xxxxxx>yyyyyy<cr><sum>

Where:

stx =	Start of TeXt (hex 02)
swa =, swb=, swc=	Status Bytes
xxxxxx=	Displayed Weight, Gross or Net Weight (Six Digits)
yyyyyy=	Tare Weight (Six Digits)
cr =	Carriage Return (hex 0D)
sum=	Checksum Character

### Format 3 – SHORT with CKSUM

<stx><swa><swb><swc>xxxxxx<cr><sum>

Where:

stx =	Start of TeXt (hex 02)
swa =, swb=, swc=	Status Bytes
xxxxxx=	Displayed Weight, Gross or Net Weight (Six Digits)
cr =	Carriage Return (hex 0D)
sum=	Checksum Character



## CONTINUOUS OUTPUT FORMATS, CONT.

### IQ355 – (Type=3)

<stx><polarity><wwwwwww><units><g/n><status><crLf>

Where:

stx =	Start of TeXt	(hex 02)
polarity =	Sign	"-" = negative, " " ( <i>blank</i> ) = positive
wwwwwww =	Weight	Seven digits
units =	Units	" " ( <i>blank</i> ) = none, L = lb, K = kg, T = tons, G = grams, O = ounces
g/n	Mode	G = Gross, N = Net
status	status	" " ( <i>blank</i> ) = valid I = invalid M = motion O = over cap
CRLF =	Carriage Return with Line Feed	(hex 0D) with (hex 0A)

### SB500 (with Traffic Light) – (Type = 5)

%NDDDDDDDDDT<CR>

Where:

N = Panel number for a daisy chain configuration

D = Byte of data to display at respective location on the scoreboard

T = Control character for the traffic light. Valid characters for T are:

G = Turn on Green light

R = Turn on Red light

" " (*space*) = no lights on

<CR> = Carriage Return

### SB250/500M – (Type= 6)

%NDDDDDDDDDD<CR>

Where:

N = Panel number for a daisy chain configuration

D = Byte of data to display at respective location on the scoreboard

<CR> = Carriage Return

## CONTINUOUS OUTPUT FORMATS, CONT.

### SB-200 – (Type= 10)

<cr><s><xxxxxx><d><c><uu><m><etx>

Where:

cr =	Carriage Return	(hex 0D)
s =	Sign	"-" = negative, " " ( <i>blank</i> ) = positive
Xxxxxx =	Weight	Six digits
d =	Decimal point	Always in data string
c =	Weight Status	O = over capacity M = motion e = weight not currently being displayed
uu =	Units	tn, lb, oz, t, kg, g
m =	Mode	G = Gross, N = Net
etx=	End Text	(hex 03)

## CONTINUOUS OUTPUT FORMATS, CONT.

### Weight on Demand Format

If continuous output has not been selected for the COM Ports (CONT=NO), the 225 indicator will respond to a weight request (ENQ) as follows.

The host device (computer) sends:

ENQ - (hex 05)

The 225 will respond:

<s><xxxxxx><d><uu><m><cc><cr>

Where:

s =	Sign	"-" = negative, " " ( <i>blank</i> ) = positive
xxxxxx.xxx =	Weight	Six digits
d =	Decimal point	Added to string if enabled in setup
uu =	Units	tn, lb, oz, t, kg, g
m =	Mode	G = Gross, N = Net
cc =	Weight Status	OC = over capacity CZ = center of zero MO = motion ee = weight not currently being displayed
cr =	Carriage Return	(hex 0D)

# CONTINUOUS OUTPUT FORMATS, CONT.

## SMA Weight on Demand Format

If continuous output has not been selected for the COM Ports (CONT=NO), the 225 indicator will respond to a SMA weight request as follows.

The host device (computer) sends:

```
<lf> W <cr>
```

The 225 will respond:

```
<lf><s><r><n><m><f><xxxxxx.xxx><uuu><cr>
```

Where:

lf =	Line Feed	
s =	Flags	Z= center of Zero, O = Over cap, E = zero Error, e = weight not currently being displayed
r =	Range	1, 2, 3, ...
n =	Mode	G = Gross, T = Tare, N = Net
m =	Motion	M = Motion, " "(blank) = no motion
f =	Custom	Custom flag
xxxxxx.xxx =	Weight	Six digits with decimal point
uuu =	Units	ton, lb, oz, t, kg, g
cr =	Carriage Return	(hex 0D)

# ASCII COMMANDS

The Model 225 indicator will respond to ASCII coded serial data, in the format below, when input to the RXD serial input.

- The commands are ASCII strings, without spaces, followed by a carriage return <cr> and can be upper or lower case, or any combination.
- Data inside parenthesis is the parameter item designator (e.g. "PWC (1) <cr>" requests the value of PWC number 1 preset to be transmitted from the indicator).
- A command followed by the equal sign "=" is a set command and must be followed by the data desired to be stored for that parameter.
- Any command without an equal sign requests data to be transmitted from the indicator (a query command).
- Commands that set more than one value use commas between the values.
- To verify data has been stored correctly in the indicator, send the command to request the same data to be transmitted from the indicator.

## Commands

<u>Command</u>	<u>Response</u>	<u>Description</u>
Gross<cr>	1000lb G	Transmit Gross Weight
Tare<cr>	100lb T	Transmit Current Tare
Tare=123<cr>	OK	Set Tare To Value
Net<cr>	900lb N	Transmit Net Weight
PWC (1)<cr>	100lb PWC1	Transmit PWC Value
PWC (1)=123<cr>	OK	Set PWC To Value
Fast<cr>	100lb F	Transmit 2 Speed DFC Fast Value
Fast=123<cr>	OK	Set 2 Speed DFC Fast Value
Slow<cr>	100lb F	Transmit 2 Speed DFC Slow Value
Slow=123<cr>	OK	Set 2 Speed DFC Slow Value
Fill<cr>	100lb F	Transmit 1 Speed DFC Value
Fill=123<cr>	OK	Set 1 Speed DFC Value
Trim<cr>	100lb TRM	Transmit DFC Trim Value
Trim=123<cr>	OK	Set DFC Trim Value
Accum(g)<cr>	1000lb	Transmit Accumulator Valid Selections G/N/C/1-7
Accum(n)=100<cr>	OK	Set Accumulator
Ing(1)<cr>	1 100lb 1200lb	Transmit Ingredient (Bin, Fast, Slow)
Ing(1)=1,100,150<cr>	OK	Set Ing (Bin, Fast, Slow)
Trim(1)<cr>	100lb TRM1	Transmit Batcher Trim For Ing X
Trim(1)=100<cr>	OK	Set Batcher Trim
ID(<cr>	id(x)=r,1,2	List ALL IDs ID(ID)=Ref, Tare, Accum
ID(1)<cr>	id(1)=r,1,2	List A Single ID
ID(1)=ref,100,0<cr>	OK	Add Or Replace An ID
Key(x)<cr>	Results of (x) function.	Performs function of (x) as if key was pressed. See Valid Key Names.

<cr> = carriage return

## ASCII COMMANDS, CONT.

### Valid Key Names

The following is a list of valid key names for the ASCII COMMAND Key(x).

<u>Key Name</u>	<u>Comments</u>
asterisk or *	Use either the word "asterisk" or the symbol "*"
0 to 9	Numeric characters
A to Z	Uppercase alpha characters
a to z	Lower case alpha characters
enter	
time	
net	Toggles between Gross and Net weight modes
preset	
count	
tare	Stores the current gross weight as the new tare weight. (The same function as the diamond "T" key).
tarewt	Displays the current tare weight for three seconds. (The same function as the weight "T" key).
print	
off	Turns the indicator off. ( <b>NOTE:</b> The <b>ON/OFF</b> key on the keypad must be pressed to turn the indicator back on).
zero	
units	Toggles between the base units and converted units selected during Setup and Calibration.
start	
stop	
mem	
id	
accum	
delete	
dump	
gross	Selects Gross weight only, DOES NOT toggle between Gross and Net weight modes. (See Net, above).

### Error Responses

<u>Response</u>	<u>Description</u>
?	Did not understand the command.
MODE	This command not supported by the mode of operation. For example: no lng() if not batcher.

# TROUBLESHOOTING

## Error Codes

The Model 225 indicator is equipped with software that indicates when an error in the operation takes place. The following lists the error codes displayed by the 225 along with their meaning. Should you encounter an error code, please refer to this list for the cause.

### ANALOG HIGH



1. The load cell input is above the allowed range of the indicator.

CORRECTIVE ACTION: Check for improper load cell wiring, excessive load, and for output of 1 to 40mV.

2. Load cell or circuit failure.

CORRECTIVE ACTION: Consult your scale service provider.

### ANALOG LOW



1. The load cell input is below the allowed range of the indicator.

CORRECTIVE ACTION: Check for improper load cell wiring and for output of 1 to 40mV.

2. Load cell or circuit failure.

CORRECTIVE ACTION: Consult your scale service provider.

### OVERCAP



The load on the scale exceeds the scale capacity (105% of capacity if USA=YES or plus 9 divisions if USA=NO). May indicate miscalibration.

CORRECTIVE ACTION: Remove the over capacity load from the scale platform. Consult your scale service provider regarding recalibration.

### CHECK MATL

In a Digital Fill Control or Batcher operation configured for decumulative operation (ACCUMLATE=YES) there is not enough material to start the operation.

CORRECTIVE ACTION: Determine the reason for the error display and take the appropriate corrective action.

### CHECK ZERO

In a Digital Fill Control or Batcher operation with DUMP GATE=YES and AUTO TARE=NO the weight is above the zero tolerance value.

CORRECTIVE ACTION: Determine the reason for the error display and take the appropriate corrective action.

# TROUBLESHOOTING, CONT.

## COLD RAM

The external ram has failed to retain memory.

CORRECTIVE ACTION: Consult your scale service provider.

## CAL LOST CONFIG REQUIRED SCALE X

EEPROM checksum failure. Indicates improper stored calibration data, calibration is necessary. Note that X is the scale number (1, 2 or 3).

CORRECTIVE ACTION: Recalibrate with calibrated test weight.

## ERROR

An invalid keypad entry was attempted:

- A. **PRINT** key pressed with a negative weight.
- B. **TARE** key pressed to enter a push button tare value of a negative value.
- C. **ENTER** key pressed to enter a tare weight value that exceeds the scale capacity.
- D. **ENTER** key pressed to enter a tare weight value that is inconsistent with the scale division value (i.e. attempt to enter a tare of 123 with scale divisions of 5).
- E. **ZERO** key pressed when the gross weight is outside the scale zero weight range.
- F. **lb/kg** key pressed to change to kilograms when the kilogram tare weight value exceeds 4 digits in length.

CORRECTIVE ACTION: Determine which of the reasons for the error display is applicable and take the appropriate corrective action.

## A2D ERROR

■■■■ ■■■■ ■■■■ ■■■■ ■■■■ ■■■■ ■■■■ ■■■■

The Analog to Digital converter chip has stopped producing weight.

CORRECTIVE ACTION: Consult your scale service provider.

## DRDY ERROR

■■■■ ■■■■ ■■■■ ■■■■ ■■■■ ■■■■ ■■■■ ■■■■

The Analog to Digital converter chip is not responding.

CORRECTIVE ACTION: Consult your scale service provider.

## FILE FULL

The operator is attempting to add an ID when the ID file is full.

CORRECTIVE ACTION: Determine the reason for the error display and take the appropriate corrective action.



## TROUBLESHOOTING, CONT.

### HUH?

**UNITS** key pressed in an attempt to perform a “unit” conversion that is not allowed.

CORRECTIVE ACTION: Determine the reason for the error display and take the appropriate corrective action.

### ID IN USE

The operator is attempting to add an ID that already exists.

CORRECTIVE ACTION: Chose another number for the ID.

### ID NOT FOUND

The operator is attempting to use an ID that does not exist.

CORRECTIVE ACTION: Determine the reason for the error display and take the appropriate corrective action.

### NO TARE

**NET** key pressed with no stored tare weight value.

CORRECTIVE ACTION: Determine the reason for the error display and take the appropriate corrective action.

### OVERFLOW



The indicator is attempting to display a positive number greater than seven (7) digits in length or a negative number of more than six (6) digits.

CORRECTIVE ACTION: Return to Gross Weight mode and review Tare value. May indicate miscalibration.

### TOO BIG

**UNITS** key pressed in an attempt to perform a “unit” conversion where the interval would have been greater than 50.

CORRECTIVE ACTION: Determine the reason for the error display and take the appropriate corrective action.

### TOO SMALL

**UNITS** key pressed in an attempt to perform a “unit” conversion where the interval would have been less than .0001.

CORRECTIVE ACTION: Determine the reason for the error display and take the appropriate corrective action.

# TROUBLESHOOTING, CONT.

## UNSTABLE

Motion is present when trying to power up, print, zero or perform a push button tare function.

CORRECTIVE ACTION: Wait for a stable weight display (*STABLE* symbol on) before performing any of these operations.

## WRONG RAM

During memory access to the external ram, an error has occurred.

CORRECTIVE ACTION: Consult your scale service provider.

## XRAM FAILURE

The power up test of external ram (the big chip in a socket) has failed.

CORRECTIVE ACTION: Consult your scale service provider.

## Before You Call Service

The Model 225 indicator has been designed to provide you with years of trouble-free operation. In spite of this, troubles sometimes happen. Before calling for service assistance, you should make some initial checks to verify that a problem does exist. The following describes several types of symptoms along with suggested remedies.

<u>PROBLEM</u>	<u>POSSIBLE SOLUTIONS</u>
Display does not turn on	Is the AC power cord fully inserted into the wall receptacle? Check wall receptacle for proper AC power. Try another electrical appliance in the same receptacle. Does it work? Check the circuit breaker. Has there been power failure?
Incorrect weight displayed	Has the indicator been calibrated? Insure that the scale platform is not touching an adjacent object. Check the load cell connector wiring. If using four (4) wire load cells, insure the sense lead jumper (J9) is installed. Have proper operation procedures been followed?
Indicator will not display weight	Refer to Error Codes section and make certain that the <b>OVERCAP</b> message is not displayed. If so, and scale is not loaded, perform the calibration procedure.

# TEST MODE AND DIAGNOSTIC DISPLAY

## Test Mode

The Test mode is used to display the software revision number, the calibration “C” numbers, and conduct a test of all display elements. The test consists of 6 cycles:

1. With the indicator in normal operations mode, press the **SHIFT** and then **←/ESC** key.
2. The display will change to show the **FUNCTION=** prompt.
3. Press the **UNITS** key.
4. The display will show the model number and the software revision.
5. Next, a graphics display test will be performed.
6. After the display test, the 225 will display the calibration “C” numbers (C1 to C4) for approximately 5 seconds.
7. After displaying the “C” numbers, the display will return to normal operation.

## Diagnostic Display

The 225 can provide a diagnostic display to help determine how the load cells and weight measuring circuitry are functioning.

1. With the indicator in normal operations mode, press the **SHIFT** key and then the Navigation **ENTER** key (red square key).
2. The display will change to show the **SETUP/REVIEW MENU**.
3. Using the numeric keys, enter 225 and then press the **ENTER** key.
4. The display will change to show the diagnostic display:

SCALE* NUMBER	RAW ADC* COUNT	SCALE mV* INPUT	SCALE* WEIGHT	SCALE* UNITS
S1	XXXXXXXXXX	XX. X mV	XXXXXXX	1b G
S2	XXXXXXXXXX	XX. X mV	XXXXXXX	1b G
S3	XXXXXXXXXX	XX. X mV	XXXXXXX	1b G
TESTONLYTESTONLYTESTONLYTESTONLYTESTONLY				

**\* NOTE: Labels are for reference only and are not shown on 225 display.**



# ERASING MEMORY

## Erase Ram Memory



**WARNING!** This procedure will **ERASE ALL** of the internal RAM memory! This includes the ID file, batcher info, dealer string, mode of operation, visual tickets).

If a 225 does not display properly after a program update or otherwise becomes corrupt, perform the following:

1. With the indicator in normal operations mode, press the **SHIFT** key and then the Navigation **ENTER** key (red square key).
2. The display will change to show the SETUP/REVIEW MENU.
3. Using the numeric keys, enter 130 and then press the **ENTER** key.
4. The display will change to show a warning message.
5. To ERASE ALL the memory, press **YES** (on the soft keys) and then the **ENTER** key.
6. Otherwise, press **NO** (on the soft keys) and then the **ENTER** key to return the SETUP/REVIEW MENU.

## Erasing EEPROM Memory



**WARNING!** This procedure will **ERASE** the EEPROM calibration data. All EEPROM memory will be erased and the settings for the scales, Serial ports, etc. will be set to their default values.

1. With the indicator in normal operations mode, press the **SHIFT** key and then the Navigation **ENTER** key (red square key).
2. The display will change to show the SETUP/REVIEW MENU.
3. Using the numeric keys, enter 160 and then press the **ENTER** key.
4. The display will change to show a warning message.
5. To ERASE the calibration data, press **YES** (on the soft keys) and then the **ENTER** key.
6. Otherwise, press **NO** (on the soft keys) and then the **ENTER** key to return the SETUP/REVIEW MENU.



# FINE SPAN ADJUSTMENT

If after performing linearization testing, an error in the overall weight (span setting of the scale) or an error in a specific range of weight is found, adjustments can be made using the procedures described below.

With the indicator ON, press the **SHIFT** key and then press the Navigation **ENTER** key (red square key in center of the Navigation arrows). The display will change to show the SETUP/REVIEW MENU.

With the SETUP/REVIEW MENU displayed,

1. Press the **1** key and then the **ENTER** key to proceed to SETUP MENU #1.
2. Press **NEXT** (Navigation Keys  $\nabla$  Down Arrow) to proceed to SETUP MENU #2.
3. Press the **5** key and then the **ENTER** key to proceed to SCALE 1 CALIBRATION MENU.

## 4. FINE SPAN (FINE SPAN ADJUSTMENT)

If Fine Span Adjustment is desired, place a calibrated test weight on the scale and with the SCALE 1 CALIBRATION MENU displayed, press the **4** key and then the **ENTER** key. The display will change to show SCALE 1 FINE SPAN ADJUST. Note that **ADJ = XXXXXXXX** is the current displayed weight.

- Press **UP** (Navigation Keys  $\triangle$  UP Arrow) to increase the span.
- Press **DOWN** (Navigation Keys  $\nabla$  Down Arrow) to decrease the span.
- Press **EXIT** (Navigation Keys  $\triangleleft$  Left Arrow) to save the new setting and return to the SCALE 1 CALIBRATION MENU.
- Press the Navigation Keys  $\triangle$  UP Arrow four (4) times to reset the indicator and return to normal operations.

## 5. HI RES (HIGH RESOLUTION ADJUSTMENT)

If High Resolution Weight adjustment is desired, place a calibrated test weight on the scale and with the SCALE 1 CALIBRATION MENU displayed, press the **5** key and then the **ENTER** key. The display will change to show SCALE 1 HIRES ADJUSTMENT. Note that **HIRES=XXXXXX** is the active weight in “high resolution” mode (in 1/10 interval).

- Press **UP** (Navigation Keys  $\triangle$  UP Arrow) to increase the span.
- Press **DOWN** (Navigation Keys  $\nabla$  Down Arrow) to decrease the span.
- Press the **ZERO** key to zero the scale.
- Press the **PRINT** key to print the weight (followed by the text TEST).
- Press **EXIT** (Navigation Keys  $\triangleleft$  Left Arrow) to save the new setting and return to the SCALE 1 CALIBRATION MENU.
- Press the Navigation Keys  $\triangle$  UP Arrow four (4) times to reset the indicator and return to normal operations.

# VIEW AUDIT TRAIL COUNTERS

A Category 1 Audit Trail is provided on the Model 225 with two event counters that increment when a change is made to features that are required by NTEP or OIML to be sealed. One counter is designated for calibration parameters and one is designated for configuration changes as required in NCWM Publication 14, 2007. Each event counter has a capacity to record 999 changes. The data for the counters is maintained in non-volatile memory and can be viewed or printed by a weights and measures inspector. When selected, the display will show a 3-digit number representing the Calibration and Configuration counters.

## To View the Audit Trail Counters

With the indicator ON, press the **SHIFT** key and then press the Navigation **ENTER** key (red square key in center of the Navigation arrows). The display will change to show the SETUP/REVIEW MENU.

```
          SETUP/REVIEW MENU
1. ENTER CALIBRATION AND SETUP
2. VIEW AUDIT TRAIL COUNTERS
3. CALIBRATE SCALE 1
                                     9. DEL CUSTOM TICKET
                                     10. PRINT SETUP
Enter Selection: 1  █ EXIT
```

## 2. VIEW AUDIT TRAIL COUNTERS

With the SETUP/REVIEW MENU displayed, press the **2** key and then the **ENTER** key. The display will change to show COUNTER MENU.

```
          COUNTER MENU
CALIBRATION COUNTER      : XXX
CONFIGURATION COUNTER   : XXX
Press PRINT key to print counters.
Press any other key to EXIT
```

### CALIBRATION COUNTER (CALIBRATION COUNTER)

The CALIBRATION COUNTER : XXX is the current value for the number of times the 225 has been calibrated.

### CONFIGURATION COUNTER (CONFIGURATION COUNTER)

The CONFIGURATION COUNTER: XXX is the current value for the number of times the 225 has had a configuration change.

Press the **PRINT** key to print the counters using the selected printer port enabled during Calibration and Setup. Otherwise, press any key (alphanumeric, soft or the navigation keys) on the keypad to exit and return to the SETUP/REVIEW MENU.



# ELECTRONIC TALLEY ROLL (ETR) FILE

The 225 is equipped with an Electronic Talley Roll (ETR) feature that stores the weight and a consecutive transaction number each time the indicator receives a Talley command from the computing peripheral. The data is maintained in non-volatile memory and is available for use by a weights and measures inspector.

When enabled, each time the indicator receives an ETR request (SMA XT command), the gross weight and an internal consecutive transaction number (that cannot be modified) will be stored in memory. The 225 has sufficient memory to create an ETR file that will store up to 7000 transactions. The ETR file is structured such that when its capacity is reached, the newest transaction will replace the oldest. The ETR file can only be displayed and cannot be manually cleared or printed.

## Enabling the Electronic Talley Roll (ETR)

To enable the Electronic Talley Roll (ETR) feature, the following parameters must be set:

In SETUP MENU #1

- USA=NO
- MODE OF OP= (0, 2, 3, 4 or 5)

In SETUP MENU #2, 1. SERIAL, 2. COMX (Note that X is the COM port the indicator receives a Talley command from the computing peripheral)

- 5. CONT=NO
- 6. TYPE=9 TALLEY

## Viewing the Electronic Talley Roll (ETR) File

1. With the indicator in normal operations mode, press the **SHIFT** and then **← /ESC** key.
2. The display will change to show the **FUNCTION=** prompt.
3. Press the **ZERO** key.
4. The display will show **FIND ETR=0**.
5. Using the numeric keys, enter the transaction number to find and then press the **ENTER** key.
6. The indicator will display **ETR=XXXXXXYY** for 3 seconds. Note that **XXXXXX** is the weight and **YY** is the units of measurement.
7. After displaying the record, the display will return to normal operation.

# ELECTRONIC TALLEY ROLL (ETR) FILE, CONT.

## Recording a Electronic Tally Roll Transaction Record

To record an ETR transaction record, the computing peripheral (host device) transmits the SMA XT command (also called TALLEY ON STABLE) to the weight indicator.

### Electronic Talley Roll (ETR) Format

The host device (computing peripheral) sends:

```
<0Ah><XT><ODh>
```

The 225 weight indicator will respond by transmitting the following to the host device:

```
<s><xxxxxx><d><uu><m><cc>#nnnnnn<cr>
```

Where:

s =	Sign	"-" = negative, " " ( <i>blank</i> ) = positive
xxxxxx =	Weight	Six digits
d =	Decimal point	Added to string if enabled in setup
uu =	Units	tn, lb, l/o, oz, t, kg, g
m =	Mode	G = Gross, N = Net
cc =	Weight Status	OC = over capacity BZ = below zero MO = motion ee = weight not currently being displayed
#nnnnnn	Consecutive Number	
cr =	Carriage Return	(hex 0D)



**NOTE:** The weight and consecutive number data is only stored in the indicator's non-volatile memory and transmitted to the host device when the weight is stable (no motion).

## DELETING CUSTOM TICKETS

With the indicator ON, press the **SHIFT** key and then press the Navigation **ENTER** key (red square key in center of the Navigation arrows). The display will change to show the SETUP/REVIEW MENU.

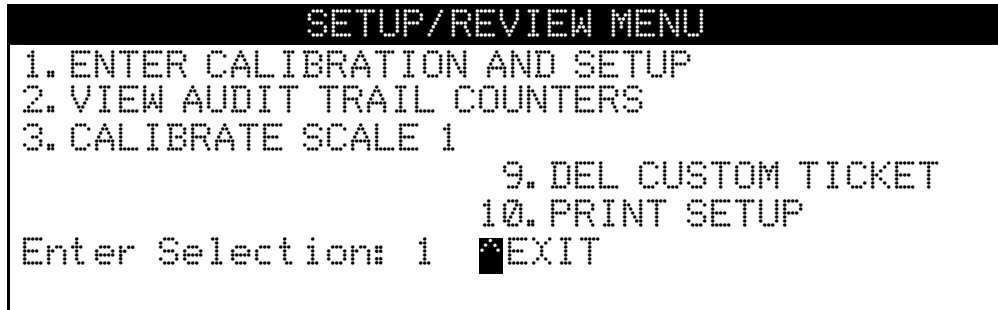

### 9. DEL CUSTOM TICKET (Delete Custom Ticket)

With the SETUP/REVIEW MENU displayed, press the **9** key and then the **ENTER** key. The display will change to show the Delete Custom Ticket prompt.

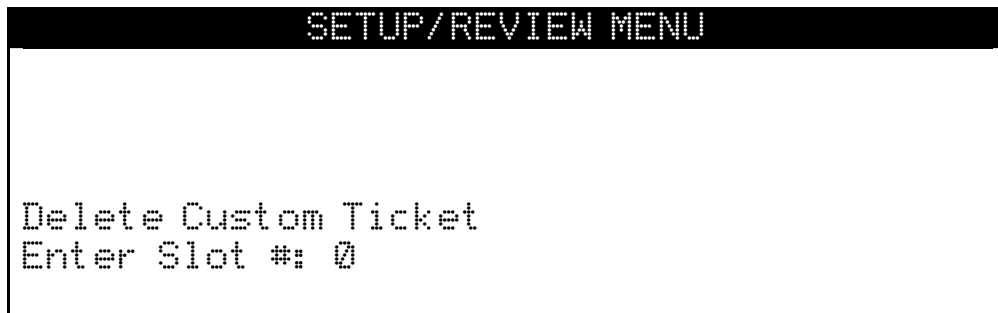

1. With the Delete Custom Ticket prompt displayed, use the numeric keys to enter the slot number (1 to 6) of the custom ticket to be deleted.
2. Press the **ENTER** key to delete the ticket and return to the SETUP/REVIEW MENU.
3. Repeat the procedure for each custom ticket to be deleted.
4. After the last custom ticket has been deleted, press the **ENTER** key to return to the SETUP/REVIEW MENU.

Press **EXIT** (Navigation Keys  $\Delta$  UP Arrow) to reset the indicator and return to normal operations.

# PRINT SETUP

With the indicator ON, press the **SHIFT** key and then press the Navigation **ENTER** key (red square key in center of the Navigation arrows). The display will change to show the SETUP/REVIEW MENU.

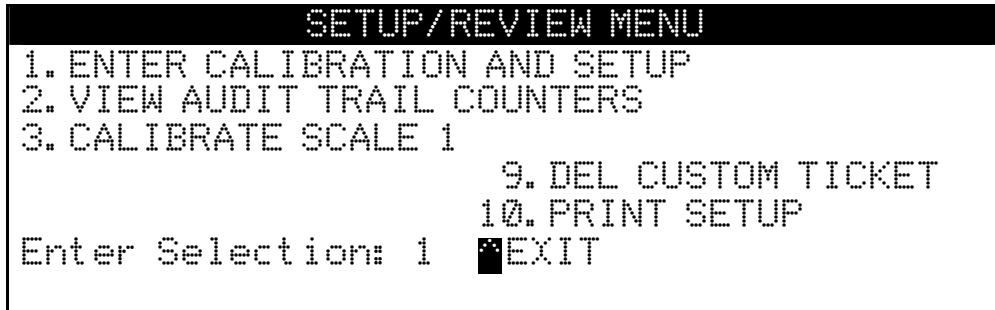

## 10. PRINT SETUP (Print Setup)

With the SETUP/REVIEW MENU displayed, press the **1** and **0** keys and then the **ENTER** key to print a hard copy of the 225 SETUP PARAMETERS.

**NOTE:** The hard copy will print using the PRINTER SERIAL port with the parameters selected during Calibration and Setup and return to the SETUP/REVIEW MENU.

Press **EXIT** (Navigation Keys  $\Delta$  UP Arrow) to reset the indicator and return to normal operations.

# LEAD AND WIRE SECURITY SEAL INSTALLATION

If your Model 225 indicator is used in a commercial application and your local metrology laws require the use of physical sealing, a lead and wire security seal can be installed to prevent the rear panel from being removed from the indicator to gain access to the calibration jumper (P8) thereby preventing unauthorized access to the calibration adjustments. Refer to the Figure No. 18 for a suggested location and details on the installation of the security seal.

**NOTE:** In order to install the lead and wire security seal, two (2) acorn nuts on the rear panel **MUST** be replaced with drilled acorn nuts. They are available from the Cardinal Scale Mfg. Parts Department. The part number is 8200-B026-08 (NUT HEX #10-32 ACORN SS DRILLED).

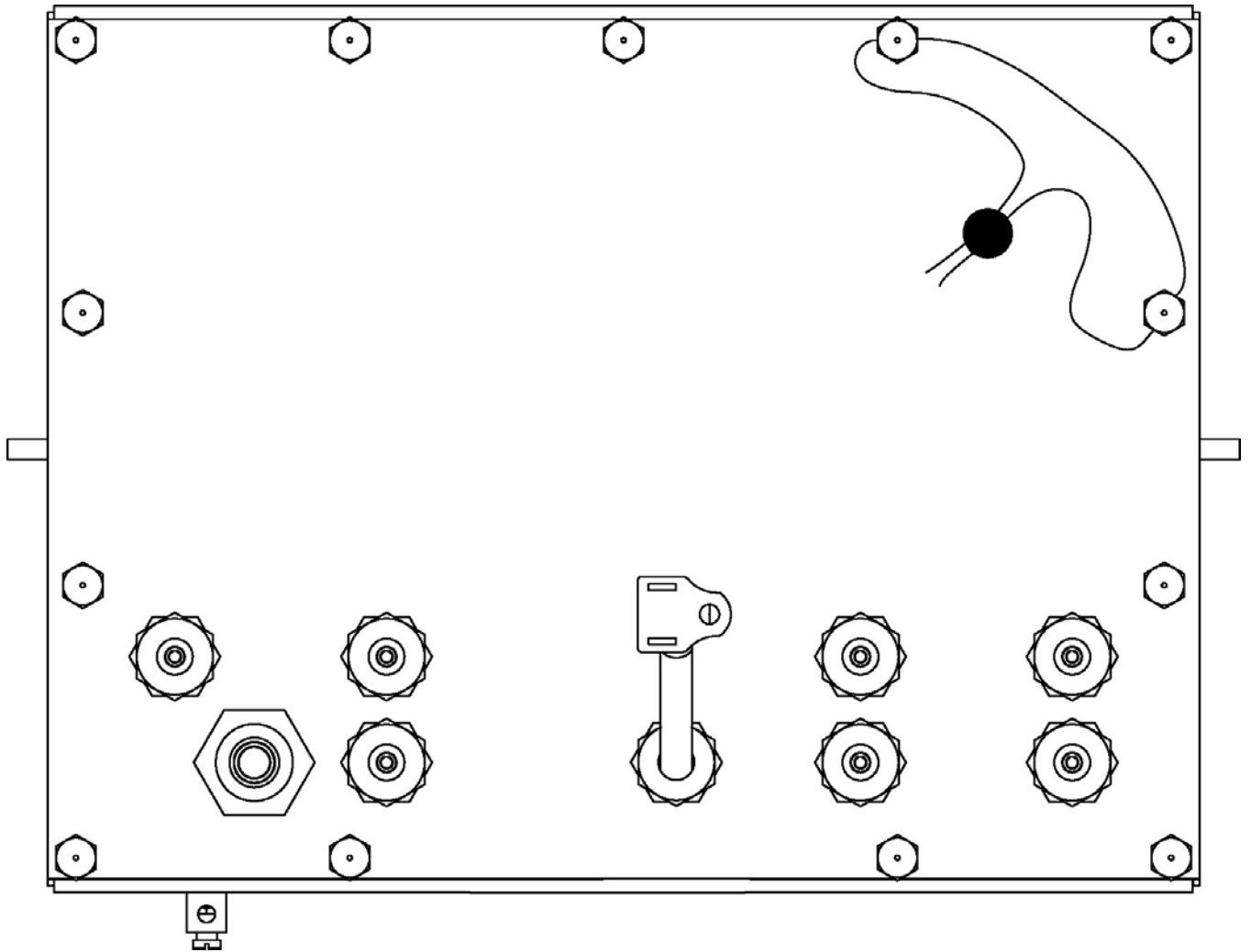
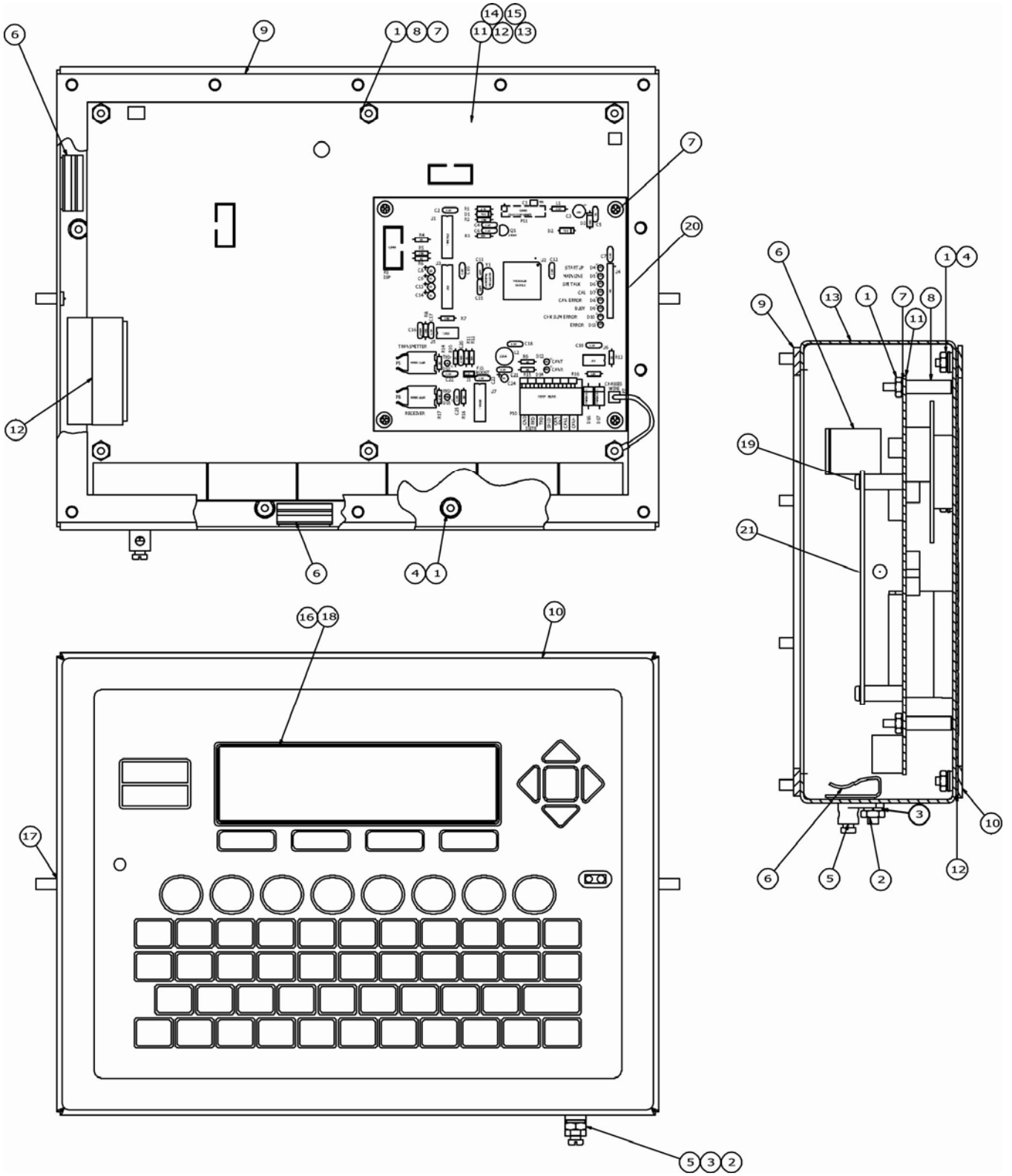

Figure No. 18

## PART IDENTIFICATION (Front Assembly)

ITEM #	QTY.	PART NUMBER	DESCRIPTION
1	18	6013-0039	NUT HEX # 6-32
2	1	6013-0297	NUT # 10-32 HEX
3	1	6024-0037	WASHER LOCK HELICAL SP # 10 REG SS
4	12	6024-1078	WASHER FLAT # 6 NEOPRENE BACKING SS
5	1	6610-5002	GROUND LUG L-35
6	2	6610-5007	CABLE CLIP, 1" x 1" GREY
7	6	6680-0004	WASHER LOCK INT TOOTH # 6 TYPE A Z-PL
8	6	6680-0219	SPACER # 6 X .813 NYLON
9	1	8200-B309-08	GASKET FOR 220 ENCLOSURE
10	1	8200-C312-0A	WELDMENT: BEZEL FOR 220
11	1	8200-D358-0A	PCB ASS'Y 225-USA CONTROLLER
12	1	8200-D358-1A	PCB ASS'Y 225-NWS CONTROLLER
13	1	8200-D358-4A	PCB ASS'Y 225-INTL CONTROLLER
14	1	8200-D358-6A	PCB ASS'Y 225-USA-ICAN CONTROLLER
15	1	8200-D358-7A	PCB ASS'Y 225-INTL-ICAN CONTROLLER
16	1	8200-D360-08	KEYPAD: 225 DWI
17	1	8200-D365-0A	WELDMENT: ENCLOSURE, FRONT
18	1	8200-D379-08	KEYPAD: 225 AU
19	4	6021-0661	SCW PAN-HEAD..MACHINE-SCW 06-32X.250
20	1	8200-C384-0A	PCB ASS'Y 225CANP CAN INTERFACE
21	1	8200-C384-1A	PCB ASS'Y 225CANG CAN INTERFACE

# PART IDENTIFICATION (Front Assembly)



## PART IDENTIFICATION

### (Rear Assembly)

ITEM #	QTY.	PART NUMBER	DESCRIPTION
1	4	6013-0315	NUT # 6-32 HEX SMALL PATTERN Z/P
2	7	6540-1104	PLUG, HOLE 0.343" X 0.187" X 1" LG, SILICONE RUBBER
3	1	6610-1506	CONN GLAND .160-.310 GRIP .60 MTG NICKEL
4	1	6610-2081	CONN GLAND .170-.470 GRIP .875 MTG BLK
5	7	6610-2248	CONN GLAND .187-.312 GRIP .599 MTG BLK
6	4	6680-0004	WASHER LOCK INT TOOTH # 6 TYPE A Z-PL
7	4	6680-0138	SPACER # 6 x .187 NYLON
8	4	6680-1107	SPACER # 4-40 x .750 3/16 HEX ALU. Z/P
9	2	6680-2105	SPACER # 4-40 x .750 NYLON
10	1	6800-1032	POWER SUPPLY 15VDC/1.4AMP (UNIVERSAL IN)
11	1	6910-0171	NUT CONDUIT 1/2 LOCK
12	1	6980-0014	CABLE TIE 4" WHITE
13	1	6980-0250	POWER CORD H05VV-F3G 1mm, 10A/250V, BLACK
14	1	6980-1030	POWER CORD 18/3 SVT CEE 6.3 FT
15	1	6980-1062	POWER CORD 10A/250V AUSTRALIA AS31121990
16	1	8200-B104-08	LABEL: 205/210 TERM. BLOCK
17	1	8200-B212-0A	CABLE: GROUND 205/210
18	1	8200-B237-0A	CABLE: AC POWER W/FILTER 205/210 DWI
19	1	8200-B238-0A	CABLE 210-FE POWER SUPPLY OUTPUT
20	1	8200-B392-0A	CABLE: AC POWER W/FILTER 205/210 DWI
21	1	8200-C363-08	POWER SUPPLY COVER
22	1	8200-C366-0A	WELDMENT: ENCLOSURE, REAR
23	1	8510-C346-0I	LABEL CAUTION HIGH VOLTAGE
24	1	6560-0311	PLUG, HOLE 0.361" – 0.427" RED LDPE



# PART IDENTIFICATION (Rear Assembly)

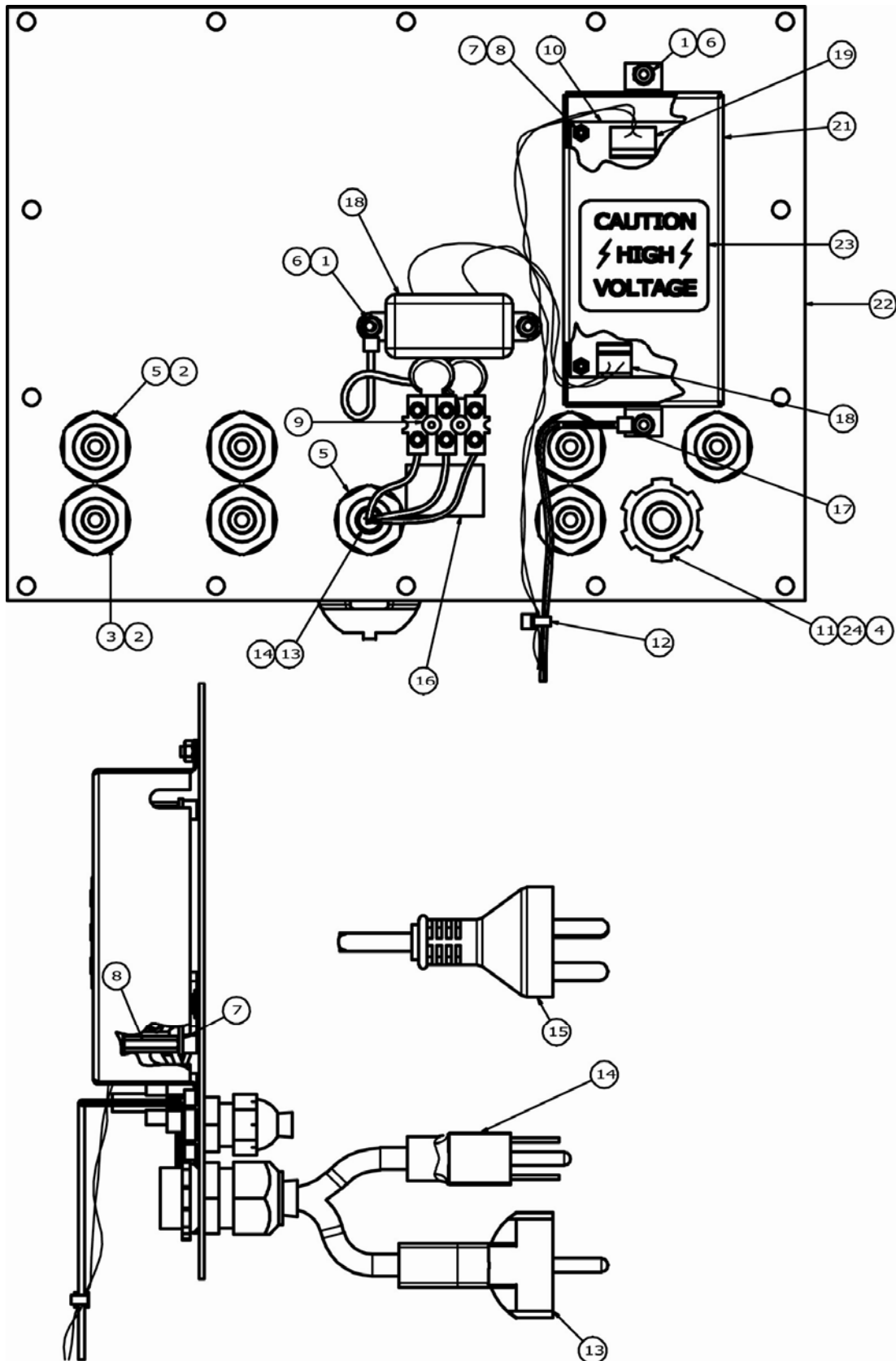

## PART IDENTIFICATION (Final Assembly)

ITEM #	QTY.	PART NUMBER	DESCRIPTION
1	1	593GR986	SERIAL TAG ASSEMBLY
2	12	6013-0433	NUT HEX #10-32 ACORN SS
3	1	6600-0059	LABEL "WEEE" .4" x .5" (WHITE ON BLACK)
4	-	-	-
5	1	8200-D371-0A	SUB-ASSEMBLY: REAR ENCLOSURE
6	1	8200-D371-1A	SUB-ASSEMBLY: REAR ENCL W/EURO PWR CORD
7	1	8200-D373-0A	SUB ASSEMBLY: FRONT ENCLOSURE
8	1	8200-D371-2A	SUB-ASSEMBLY: REAR ENCL W/AUSTRALIA PWR CORD
9	1	8200-D373-1A	SUB ASSEMBLY: FRONT ENCLOSURE AUSTRALIA
10	2	8200-B026-08	NUT HEX #10-32 ACORN, DRILLED, SS
11	1	5930-B125-08	LABEL: ETL FOR 205/210/215/225
12	1	8200-D373-3A	SUB ASSEMBLY: FRONT ENCLOSURE EURO
13	1	8200-D373-4A	SUB ASSEMBLY: FRONT ENCLOSURE ICANG
14	1	8200-D373-5A	SUB ASSEMBLY: FRONT ENCLOSURE ICANP
15	1	8200-D373-6A	SUB ASSEMBLY: FRONT ENCLOSURE ICANGEU
16	1	8200-D373-7A	SUB ASSEMBLY: FRONT ENCLOSURE ICANPEU

# PART IDENTIFICATION

(Final Assembly)

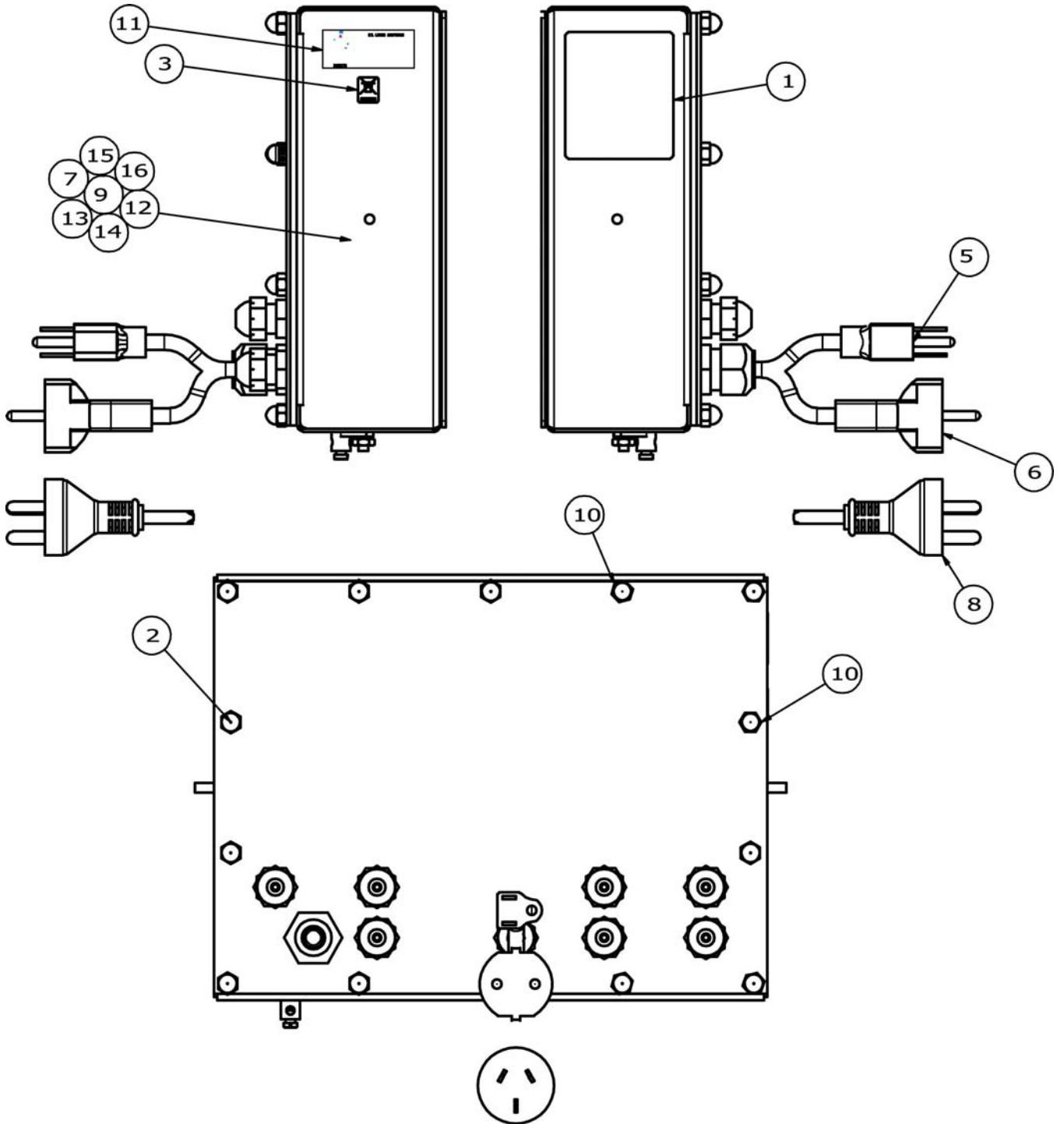

# STATEMENT OF LIMITED WARRANTY

## WARRANTY TERMS

Cardinal Scale Manufacturing Company warrants the equipment we manufacture against defects in material and workmanship. The length and terms and conditions of these warranties vary with the type of product and are summarized below:

PRODUCT TYPE	TERM	MATERIAL AND WORKMANSHIP	LIGHTNING DAMAGE See note 9	WATER DAMAGE See note 7	CORROSION See note 4	ON-SITE LABOR	LIMITATIONS AND REQUIREMENTS
<b>WEIGHT INDICATORS</b>	90 DAY REPLACEMENT ----- 1 YEAR PARTS	YES	YES	YES	YES	NO	1, 2, 3, 5, 6 A, B, C, D
<b>LOAD CELLS</b> (Excluding Hydraulic)	1 YEAR	YES	YES	YES	YES	NO	1, 2, 3, 5, 6 A, B, C, D
<b>HYDRAULIC LOAD CELLS</b> (When purchased with Guardian Vehicle Scale)	LIFE	YES	YES	YES	YES	90 DAYS	1, 5, 6, 8 A, B, C, D
<b>HYDRAULIC LOAD CELLS</b> (When purchased separately)	10 YEARS	YES	YES	YES	YES	NO	1, 5, 6, 8, 9 A, B, C, D
<b>VEHICLE SCALE</b> (Deck and Below Excl. PSC Series)	5 YEARS	YES	YES	YES	YES	90 DAYS	1, 2, 3, 5, 6 A, B, C, D, E
<b>PSC and LSC SCALE STRUCTURES</b> (Deck and Below)	3 YEARS	YES	YES	YES	YES	90 DAYS	1, 2, 3, 5, 6, 11 A, B, C, D
<b>GUARDIAN FLOOR SCALES</b>	10 YEARS	YES	YES	YES	YES	NO	1, 2, 3, 5, 6, 9, 10 A, B, C, D
<b>ALL OTHER CARDINAL PRODUCTS</b>	1 YEAR	YES	YES	YES	YES	NO	1, 2, 5, 6 A, B, C, D, E
<b>REPLACEMENT PARTS</b>	90 DAYS	YES	YES	YES	YES	NO	1, 2, 4, 5, 6 A, B, C, D
<b>IN-MOTION VEHICLE SCALES</b>	1 YEAR	YES	YES	YES	YES	90 DAYS	1, 2, 5, 6 A, B, C, D
<b>SOFTWARE</b>	90 DAYS	YES	N/A	N/A	N/A	NO	1, 6 B, C, D



Ph. (800) 441-4237  
 E-mail: cardinal@cardet.com  
 203 E. Daugherty  
 Webb City, MO 64870

06/13  
 Printed in USA  
 315-WARRANTY-CAR-K

## APPLICABLE LIMITATIONS AND REQUIREMENTS

1. This warranty applies only to the original purchaser. The warranty does not apply to equipment that has been tampered with, defaced, damaged, or had repairs or modifications not authorized by Cardinal or has had the serial number altered, defaced or removed.
2. This warranty is not applicable to equipment that has not been grounded in accordance with Cardinal's recommendations.
3. This equipment must be installed and continuously maintained by an authorized Cardinal dealer.
4. Applies only to components constructed from stainless steel.
5. This warranty does not apply to equipment damaged in transit. Claims for such damage must be made with the responsible freight carrier in accordance with freight carrier regulations.
6. Warranty term begins with date of shipment from Cardinal.
7. Only if device is rated NEMA 4 or better or IP equivalent.
8. Lifetime warranty applies to damages resulting from water, lightning, and voltage transients and applies only to the hydraulic load cell structure itself (does not include pressure transducers, rubber seals, o-rings, and associated wiring).
9. 10 Year prorated warranty on hydraulic load cells.
10. 1 Year warranty for scale structure.
11. PSC models' warranty coverage applies only to agricultural installations on farms up to 3,000 acres (LSC models not limited in this manner).
12. Load cell kits MUST be installed in accordance with Cardinal Scale instructions. Failure to follow these instructions will void the warranty.

## EXCLUSIONS

- A.) This warranty does not include replacement of consumable or expendable parts. The warranty does not apply to any item that has been damaged due to unusual wear, abuse, improper line voltage, overloading, theft, fire, water, prolonged storage or exposure while in purchaser's possession or acts of God unless otherwise stated herein.
- B.) This warranty does not apply to peripheral equipment not manufactured by Cardinal. This equipment will normally be covered by the equipment manufacturer's warranty.
- C.) This warranty sets forth the extent of our liability for breach of any warranty or deficiency in connection with the sale or use of our product. Cardinal will not be liable for consequential damages of any nature, including but not limited to loss of profit, delays or expenses, whether based on tort or contract. Cardinal reserves the right to incorporate improvements in material and design without notice and is not obligated to incorporate said improvements in equipment previously manufactured.
- D.) This warranty is in lieu of all other warranties expressed or implied including any warranty that extends beyond the description of the product including any warranty of merchantability or fitness for a particular purpose. This warranty covers only those Cardinal products installed in the forty-eight contiguous United States and Canada.
- E.) This warranty does not cover paint coatings due to the variety of environmental conditions.
- F.) Do not cut load cell cables on load cells returned for credit or warranty replacement. Cutting the cable will void the warranty.
- G.) Software is warranted only for performance of the functions listed in the software manual and/or the Cardinal proposal.
- H.) The software warranty does not cover hardware. Warranties on hardware are provided from the hardware vendor only.
- I.) The software warranty does not cover interfacing issues to non-Cardinal supplied hardware.
- J.) The software warranty does not include automatic software upgrades unless purchased separately.



Ph. (800) 441-4237  
E-mail: cardinal@cardet.com  
203 E. Daugherty  
Webb City, MO 64870

06/13  
Printed in USA  
315-WARRANTY-CAR-K

