



Model 4300



Digital Scale

INSTRUCTION MANUAL

DORAN SCALES, INC.
1315 PARAMOUNT PKWY.
BATAVIA, IL. 60510
1-800-262-6844
FAX: (630) 879-0073
<http://www.doranscales.com>
MANUAL REVISION: 4.0
MAN0166 12/26/2002

Made in USA

Table of Contents

Table of Contents	1
Introduction	3
Unpacking Your Scale	3
Quick Start User's Guide	4
Fig. 1: Model 4300 Front Panel Layout	4
Installation	4
Electrical Connections	4
Power Up	4
Model 4300	5
Front Panel Button Operations	5
ZERO	5
UNITS	5
PRINT	6
OVER	6
UNDER	6
Basic Checkweighing Reference Guide	7
Fig. 1: Model 4300 Front Panel Layout	7
Basic Over, Under, and Accept Checkweighing Operation	7
Digital Entry of Over and Under Limits	7
Push-button Entry of Over and Under Limits	7
Five Band Checkweighing Operation	8
Digital Entry of High and Low Limits	8
Push-button Entry of High and Low Limits	8
Entering Passwords	8
Quick Setup Guide	9
Load Cell and Power Connections	9
Fig. 2: Load Cell and Power Connections	9
Option Connections	9
Fig. 3: Option Connections	10
Capacity	10
Calibration	11
Analog Setup	12
Table 1: Minimum Span Requirements	12
Detailed Parameter Setup	13
Entering and Exiting the Configuration Setup Menu	13
Entering and Exiting the Calibration Setup Menu	13
Stepping Through the Menu Parameters	14
Changing a Parameter	14
Quick Review of Setup Parameters	14
Legal for Trade Restrictions	14
Sealing the Scale Calibration Cover and Backplate	14
Setup Menus Explained (In Order of Occurrence)	15
Capacity Setup Menu	15
Calibration Menu	16
Digital Filter Setup Menu	17
Automatic Zero Tracking Setup Menu	17

Motion Aperture Setup Menu	18
Start Up Zero Setup Menu	18
Latching Zero Request Setup Menu	18
Latching Print Request Setup Menu	18
Printer Data Output Setup Menu	19
Output Formats Setup Menu	19
Baud Rate Setup Menu	19
Print Buffer Activation Menu	20
Print Buffer Address Menu 1	20
Print Buffer Address Menu 2	20
Serial Data Handshaking Setup Menu	20
Units Conversion Setup Menu	21
Start Up Units Selection Menu	21
Push-Button Function Setup Menu	21
Remote Push-Button Configuration Menu	22
Password Protection Activation Menu	22
Checklimit Entry Mode Menu	22
Checkweighing Operation Menu	22
Legal for Trade Setup Menu	23
Scale Resolution Setup Menu	23
Password Entry Menu	23
Raw Counts Display Mode	24
Configuration Mode Exit Menu	24
Data Communications	25
Introduction to Data Communications	25
RS485	26
Printer Modes	27
Data Output Format	28
Table 2: Doran Serial Protocol	29
Specifications and Interconnect Data	30
Specifications	30
Interconnect Data	30
Table 3: Load Cell Connections (TB1)	30
Table 4: Options Connections (P3)	31
Table 5: Power Connections (J4)	31
Table 6: Keyboard Connections (P4)	31
Table 7: Serial Cable Assembly with Software Handshaking	32
Table 8: Serial Cable Assembly with Hardware Handshaking	32
Fig. 4: Installation of EMI / RFI / ESD Protection Devices	33
Troubleshooting	34
General Problem Resolution	34
Resetting the Scale Parameters	35
Resetting the Scale	35
Scale and Error Messages	36
Limited Warranty Statement	38

Introduction

Introducing the Doran Scales, Inc. Model 4300 Digital Scale. This scale uses state of the art technology to provide you with a low cost solution to the most demanding weighing applications. With ease of use and setup in mind, the scale is simple to set up and ready to use. The Model 4300 offers many features. A few of these features are listed below:

- NTEP certification for Class III installations to 5,000d.
- A six digit, 0.56" red LED display for easy reading.
- lb, kg, oz, g, lb-oz display units supported.
- Fully configurable duplex printer port with RS232 support.
- Optional RS485 support
- Microprocessor monitoring system to prevent scale failure under severe fault conditions.
- Support for up to 4 350 ohm load cells
- 115/230 VAC 50/60 Hz (jumper selectable) operation.
- Field selectable digital filtering.
- Software configurable remote push-button support (Optional).
- Non NTEP parameters are user configurable.

Please be sure to read the entire manual to maximize the benefits of the Model 4300. If any questions arise, please feel free to contact the Doran Scales Technical Support Department at 1-800-262-6844.

Unpacking Your Scale

Before unpacking your Doran scale, please read the instructions in this section. Your new scale is a durable industrial product, but it is also a sensitive weighing instrument. Normal care should be taken when handling and using this product. Improper handling or abuse can damage the scale and result in costly repairs that will not be covered by the warranty. If you notice any shipping damage, notify the shipper immediately. Please observe the following precautions to insure years of trouble free service from your new scale.

- DO NOT drop the scale.
- DO NOT immerse the scale.
- DO NOT drop objects on the platform.
- DO NOT pick up the scale by the "spider."

Carefully remove the scale from the shipping carton. Be sure to retain all shipping materials in case the scale must be shipped elsewhere.

Quick Start User's Guide

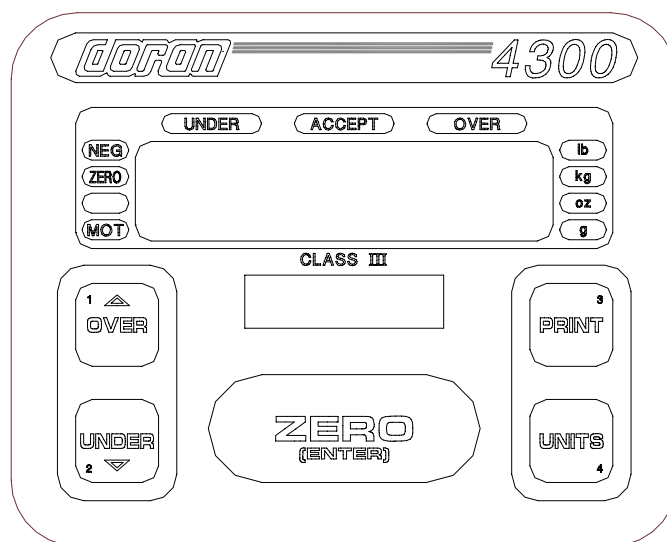

Fig. 1: Model 4300 Front Panel Layout

INSTALLATION:

The desired scale location should be flat, level and free of any obstructions, which might interfere with the operation of the scale platter. Remove the platter and locate the bubble level inside the base. Adjust the four scale feet so the bubble is centered and the platform is stable so it does not rock.

When installing your scale, make sure that the power connection is close to the scale and easily accessible.

ELECTRICAL CONNECTIONS:

Prior to connecting your Model 4300 to power, check the serial number tag on the scale for the correct operating voltage. Verify that the power matches the rated voltage.

Be sure the AC power is not excessively noisy - this can occur if large inductive loads, such as solenoids or motors, are on the same power line. The Model 4300 has a filtered power supply to reduce the effects of normal line noise, but they cannot limit severe fluctuations. If problems occur, noise-producing devices may have to be suppressed to minimize their effect.

POWER UP:

Connect the Model 4300 to a compatible power source.

Model 4300:

The Doran 4300 has a main display and ten indicator lights. These indicators provide the operator with information about the scale and the current weight operation. The main display shows the current weight or scale status. Units indicators, located on the right side of the display, show the current measurement units. Center of Zero (ZERO) and motion (MOT) indicators, located on the left side of the display, inform the operator when the scale is at Zero and when the scale is in Motion. The negative (NEG) indicator informs the operator whether the item being weighed is below or above Zero. Checkweigh information is provided by the OVER, ACCEPT and UNDER lights above the main display.

Front Panel Buttons and Operation:

Five pressure sensitive switches are located under the main display. These switches provide the operator with the ability to zero the scale, change the current units, print weight, or enter the weight limits for checkweighing.

ZERO Button:

The ZERO push button is used to zero the scale prior to making a reading. The zero button can function over the full range of the scale or it can be limited to a zero band equal to 4% of scale capacity for Canadian Legal for Trade applications.

To zero the scale, wait until the scale is stable and press the ZERO button. The scale will zero immediately. The 4300 will not "zero" if the scale is in motion. The 4300 is equipped with an optional "Zero on Demand" feature which holds "zero" requests until motion stops. This option may be activated during the scale setup procedure. Refer to the Parameter Setup section or your authorized Doran Scales dealer for details.

UNITS button:

The UNITS button allows the operator to change the scale units by pressing a button. After pressing UNITS, the units indicator will immediately display the new units. The next display update will indicate the correct weight in the new units.

The UNITS button has several configuration parameters which can disable the UNITS button or limit the display units available. Refer to the Parameter Setup section or your authorized Doran Scales dealer for details.

PRINT button:

The PRINT button allows the operator to print the current weight by pressing a button. Like the ZERO button, the user must wait for motion to stop before pressing the PRINT button. The current weight will then be transmitted to a printer or computer.

The 4300 is equipped with an optional "Print on Demand" feature which holds "print" requests until motion stops. Once stable, the scale transmits the current weight to a printer or computer. The 4300 also has several automatic print options which may be used to simplify printer operation. These options may be activated during the scale setup procedure. Refer to the Parameter Setup section or your authorized Doran Scales dealer for details.

OVER / UNDER button:

The over and under buttons are used to enter the weight values needed for checkweighing applications.

The default entry mode uses the OVER and UNDER buttons to take the current weight and scroll it up or down (arrows on the button indicate the scroll direction) until the desired "check" weight is reached. Once the desired value is reached, pressing ZERO (ENTER) will enter the desired value in the scale.

In the simplest configuration, these buttons will enter the "check" weight either by pressing the OVER or UNDER button. When in this mode, the current weight is entered as the checkweighing limits.

The 4300 also offers five band check weighing and password protection of the checkweigh limits. Refer to the Basic Checkweighing Reference Guide and the Parameter Setup section, or contact your authorized Doran Scales dealer for details.

Basic Checkweighing Reference Guide

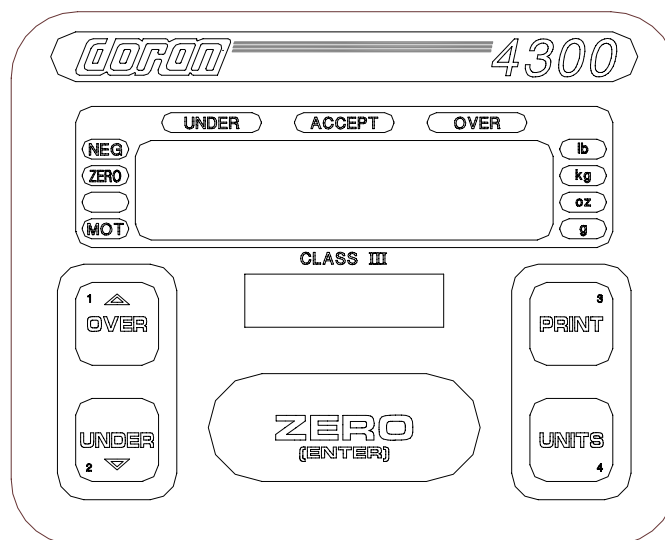

Fig. 1: Model 4300 Front Panel Layout

Basic OVER, UNDER and ACCEPT Checkweighing Operation:

- 1) Remove all items from the scale platter. (If checkweighing to zero, place the target weight on the scale.)
- 2) Press ZERO to zero the scale. The weight indication should now be zero.
- 3) Place an item on scale platter and wait for the motion (MOT) indicator to turn off, indicating a stable weight.
- 4) If the item is heavier than the over limit, the OVER light will light, If the item is lighter than the under limit, the UNDER light will light. If the weight is between the limits, the ACCEPT light will light.

Digital Entry of OVER and UNDER Limits: (default configuration)²

- 1) Zero the scale.
- 2) If available, place an item with the desired weight on the scale.
- 3) Press and release the OVER button. The over and ACCEPT lights will light followed by the lights on each side of the display. If "Ent. Cd" appears, enter the password (Refer to the "Password Entry" section.) and press ZERO.
- 4) The scale is in the scroll mode. Press either the OVER or UNDER button to increase or decrease the limit value. Holding the button longer will cause the count to accelerate. Press UNITS or PRINT to cancel.
- 5) Once the desired limit is reached, press ZERO to save the limit. The display will read "donE."
- 6) To enter the "UNDER" limit, press and release the UNDER button. Then follow step 4 and 5.

Push-button Entry of OVER and UNDER Limits: (optional configuration)^{1 2 3}

- 1) Zero the scale and place an item with the desired "OVER" weight on the scale.
- 3) Press and release the OVER button. The OVER and ACCEPT lights will light followed by "donE." The limit has been saved.
- 4) Remove the "OVER" item and place an item with the desired "UNDER" weight on the scale.
- 5) Press and release the UNDER button. The UNDER and ACCEPT lights will light followed by "donE." The limit has been saved.

Five Band Checkweighing Operation: (optional configuration)1

- 1) Remove all items from the scale platter. (If checkweighing to zero, place the target weight on the scale.)
- 2) Press ZERO to zero the scale. The weight display should now be zero.
- 3) Place an item on scale platter and wait for the motion (MOT) indicator to turn off, indicating a stable weight.
- 4) If the item is heavier than the "high" limit, the OVER light will flash. If the item is heavier than the "over" limit but lighter than the "high" limit, the OVER light will turn on. If the item is lighter than the "low" limit, the UNDER light will flash. If the item is heavier than the "low" limit but lighter than the "under" limit, the UNDER light will turn on. If the weight is heavier than the "under" limit but lighter than the "over" limit, the ACCEPT light will light.

Digital Entry of "HIGH and "LOW" Limits: (optional configuration)1 2

- 1) Zero the scale.
- 2) If available, place an item with the desired weight on the scale.
- 3) Press and hold the OVER button until the lights on each side of the display turn on and the OVER and ACCEPT lights flash. If "Ent. Cd" appears, enter the password (Refer to the "Password Entry" section.) and press ZERO.
- 4) The scale is in the scroll mode. Press either the OVER or UNDER button to increase or decrease the limit value. Holding the button longer will cause the count to accelerate. Press UNITS or PRINT to cancel.
- 5) Once the desired limit is reached, press ZERO to save the limit. The display will read "donE."
- 6) To enter the "UNDER" limit, press and release the UNDER button. Then follow step 4 and 5.

Push-button Entry of "HIGH" and "LOW" Limits: (optional configuration)2 3

- 1) Zero the scale and place an item with the desired "HIGH" weight on the scale.
- 3) Press and hold the OVER button until the scale displays "donE." The limit has been saved.
- 4) Remove the "OVER" item and place an item with the desired "UNDER" weight on the scale.
- 5) Press and hold the UNDER button until the scale displays "donE." The limit has been saved.

Entering passwords: (optional configuration)

- 1) The password on the 4300 consists of up to four digits with values from one to four.
Note: The OVER, UNDER, PRINT, and UNITS buttons are numbered from 1 to 4.
Pressing these buttons will enter the associated number.
- 2) Press the numbered keys in the correct sequence to enter the password (less than four digits are OK). The password will be displayed on the display as it is entered. If an incorrect number is pressed, start the number over and the incorrect numbers will shift off the display. The default password is ZERO (do not press and digits).
- 3) Press ZERO to accept the password displayed on the scale. If the password is incorrect, the scale cancels the operation and displays "Abort." Normal weighing then resumes. If the password is correct, the scale continues the requested activity.

1. The 4300 is shipped from the factory as an "over-accept-under" Checkweigher. The 4300 may be configured for "low-under-accept-over-high" (5 band) operation. Consult your Doran Authorized Dealer for more details.
2. The 4300 is factory configured for digital limit entry. The 4300 may be configured for push-button limit entry. Consult your Doran Authorized Dealer for more details.
3. Passwords do not work with push-button limit entry.

Quick Setup Guide

Load Cell and Power Connections:

Load cell connections are made through a connector (TB1) located at the bottom of the main PC Board (See Fig. 2). The power cord connects to a connector (J4) adjacent to the transformer. These connections are accessible by removing the rear cover. See the "Specifications and Interconnect Data" section (starting at page 30) for wiring.

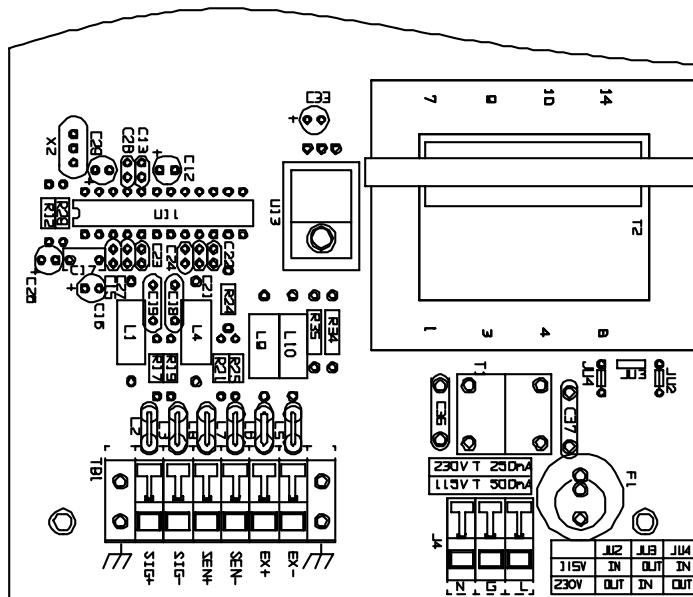

Fig. 2: Load Cell / Power connections

The Calibration push button (S1) is located behind the Calibration Access Cover. Location of the cover is on the back of the tower or bottom of the meter and is held on with just two bolts for easy access. There are no zero jumpers, span jumpers, switches or pots to adjust. The calibration push button can be accessed by removing the Calibration access cover.

Option Connections:

The Remote Switch and Serial Communications connector is found on the left side of the main PC. board. This connection (P3) is accessed by removing the rear cover. Newer 4300's will have a 4 screw contact connector (Fig. 3). Like the load cell cable and power cord, the option cables are passed through watertight fittings mounted on the bottom of the indicator.

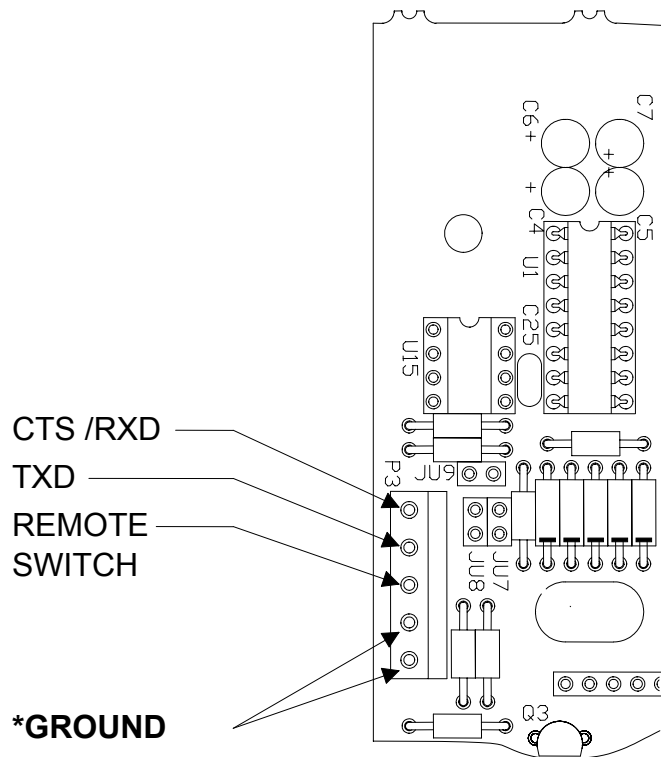

Fig. 3: Serial Communications and Remote Push Button Connections
 *NOTE: Some 4300s have one less digital ground connection off the bottom

Capacity:

Capacity selection is performed by pressing and release the Calibration button (S1) to enter the calibrate mode. Press and release **UNITS** until "**CAP 50**" appears on the display (where "50" can be any valid capacity). Once the **CAP** prompt appears, press and release **ZERO** until the desired capacity is displayed. When finished, press and release the Calibration button (S1) to exit the Cal menu, the change will automatically be saved.

Once the desired capacity has been selected, place the correct capacity label behind the capacity window located on the front panel. Secure the label with tape.

NOTE: On scales with factory installed platforms, the capacity is set at the factory. It will not be necessary to set the scale capacity.

Calibration:

- 1) The Calibration push button (S1) is located behind the Calibration Access Cover. Location of the cover is on the back of the tower or bottom of the meter and is held on with just two bolts for easy access. There are no zero jumpers, span jumpers, switches or pots to adjust. The calibration push button can be accessed by removing the Calibration access cover.
- 2) Momentarily press the Calibration button to enter the CAL menu. Press and release the **UNITS** button until "**CAL 0**" appears on the display.
- 3) Remove any unnecessary weight from the scale platter. Press **ZERO**. The display will count down from 7 to 0 and then show "**CAL FS**".

NOTE: If "rg Err" appears on the display, the calibration zero is out of range. Press zero to clear error. Refer to the analog setup section for additional information.

- 4) Press and release the **UNITS** button to scroll through the calibration capacities. Select one of the following:

CAL FS: Full load calibration.

CAL .50: Half load calibration. (50% of full load)

CAL .25: Quarter load calibration. (25% of full load)

CAL .10: 1/10th load calibration. (10% of full load)

If you want to use a weight between 10% and 100% of capacity, but not exactly 25% or 50%, select the capacity closest to the desired weight (do not use *CAL FS*). Then scroll to the exact weight on the display by pressing the **OVER** button to go higher or the **UNDER** button to go lower.

Place the correct weight on the platter. Press **ZERO** and the display will count down from 7 to 0. The display will briefly show "**donE**" and then return to the weigh mode.

NOTE: If "**SPAN E**" appears on the display, the calibration span is out of range. Press zero to clear the error and retry calibration. Refer to the analog setup section for additional information.

NOTE: Calibration at 10% of capacity has been provided as a convenience to customers with high capacity scales in remote or inaccessible locations. Scales calibrated at 10% of capacity are more likely to have significant errors at full capacity than are scales calibrated at 25% or 50%. Doran Scales recommends that all scales be calibrated at full capacity whenever possible. 10% calibration should not be used when calibrating scales for legal for trade applications.

NOTE: On scales with factory installed platforms, the calibration is performed at the factory. It will not be necessary to calibrate the scale.

Analog Setup:

NOTE: Use this section only if you are curious about the load cell output. On scales with factory installed platforms, the zero and span will lie within permissible limits. There are no jumpers, pots, or switches to adjust. Raw counts are used to verify if a load cell will operate within specified limits.

1) Momentarily press the Calibration button (S1) to enter the CAL menu. Press and release the **UNITS** button until CAP 50 (where 50 can be any valid capacity) appears on the display. Follow the procedure to select the desired scale capacity.

2) Once the correct capacity has been selected, press and release **UNITS** until in the raw counts mode. (See setup menu on page 25.)

3) Remove all weight from the scale platform.

4) Record the "no load" counts.

5) Place "Full Load" on the platform and record the "Full Load" counts. Subtract the "No Load" counts from the "Full Load" counts to calculate span. Refer to Table 1 and verify that the span falls within the limits specified for the amount of dead load present. If the readings, are outside of the limits specified, change dead load or span until the requirements are met.

6) When using 50%, 25% or 10% of full load to calibrate, calculate the span for the calibration weight in use. Divide the resulting span by .5, .25 or .1 respectively before comparing the span to the table. The "Full Load" raw counts (span + dead load) should not exceed 70.0000 counts.

Dead Load	Minimum Span
2.0000 to 17.5000 counts	5.3000 counts
17.5000 to 28.0000 counts	11.5000 counts

Table 1. Minimum Span Requirements

Detailed Parameter Setup

The Model 4300 has 26 setup and calibration parameters, which can be accessed through two setup modes. The Configuration mode will allow the user to change the scale configuration without accessing the scale calibration parameters or breaking the Weights and Measure seal. This feature makes the 4300 a versatile weighing instrument capable of meeting most common weighing needs. The Calibration mode gives access to all parameters.

Entering and Exiting the Configuration Setup Menu:

To enter the Configuration Setup Menu, unplug the scale. Hold the **PRINT** button and plug in the scale. The scale will display several startup messages and then the first menu parameter, "**Avg A6**", where "**A6**" can be any valid setting. Press the **UNITS** button to access the next menu item. If the password protection mode is on, the scale will prompt you to enter the password ("**Ent Cd**") before allowing parameter access.

To exit the Configuration Setup Menu, scroll through the menu options by pressing the **UNITS** button until "**donE n**" appears. Press **ZERO** until "**donE Y**" appears and then press the **UNITS** button. The indicator will return to the normal weighing mode. All menu sections will be saved at that time.

NOTE: No setup information is saved until scale returns to the RUN mode. In the event of a power failure while in the Configuration Setup Menu, any changes that have been made will be lost.

Entering and Exiting the Calibration Setup Menu:

To enter the Calibration Setup Menu. Remove the two screws mounting the access cover. Once opened, momentarily press the Calibration button (S1), located on the main PC board, to enter the Calibration menu. The indicator will display the first menu parameter, "**CAP 50**" (Where 50 can be any valid capacity).

To exit the Calibration Setup Menu, simply press the calibration button (S1) to exit the menus. The indicator will return to the normal weighing mode. All modified parameter selections will be saved.

NOTE: No setup information is saved until the scale returns to the RUN mode. In the event of a power failure while in the Calibration Setup Menu, any changes that have been made will be lost.

Stepping Through the Menu Parameters:

Once the Calibration Setup Menu has been entered, you may step through the menus by pressing and releasing **UNITS**. A different display prompt will appear for each parameter in the menu.

The parameter list on the following pages corresponds to the parameters available in the Calibration Setup Menu. Items available in both the configuration menu and the calibration menu will be indicated by a ‡ after the item description. Items available only in the configuration menu are indicated by ‡‡.

Some of the menu parameters, when changed affect settings of other parameters. The scale will limit these parameters or automatically set the parameters to meet the new limits.

Changing a Parameter:

After finding the desired menu item, the parameters for that item may be changed. Press and release **ZERO** to step through the parameter list for that item. The list of choices will repeat if you keep pressing and releasing **ZERO**. When you have found the desired setting, press **UNITS** to go to the next menu item.

Quick Review of Setup Parameters:

Setup parameters for the 4300 may be quickly reviewed without opening the scale. Remove power and press and hold the **ZERO** button while you apply power. Hold the button until the scale begins to scroll through the setup parameters. The button may be released anytime after the review has begun. After the parameters are displayed, the scale will return to the normal weighing mode automatically.

Legal for Trade Restrictions:

When the Legal for Trade mode is enabled, it automatically disables some menus and parameter options. This is done to comply with NTEP requirements. The menus and parameter sections are shown on the following pages. Those menus and/or parameters, not available when in the Legal for Trade mode, are marked by an asterisk *.

Sealing the Scale Calibration Cover and Backplate:

After all setup changes are finished and the indicator is in the normal weighing mode, re-install the access cover. Make sure the access cover and all the screws are re-installed in their original locations.

CALIBRATION COVER: Even pressure is applied to 2 bolts. It will prevent any gaps between the backplate, the gasket, and the case, thereby preventing debris and moisture from getting into the scale. The factory recommended torque specification is 6in-lbs.

TOWERS: Even pressure is applied to all 22 bolts. It will prevent any gaps between the backplate, the gasket, and the case, thereby preventing debris and moisture from getting into the scale. The factory recommended torque specification is 6in-lbs.

METERS: Completely tighten the four backplate screws. The meter has a built in design that will prevent crushing the gasket from overtightened bolts. The average factory torque setting is between 25 to 30in-lbs.

Setup Menu Explained (In order of occurrence)

Capacity Setup Menu

CAP	Capacity Select Menu Allows the selection of scale capacity.
5	5 pounds
6	6 pounds
10	10 pounds
15	15 pounds ^{2, 3}
20	20 pounds ³
25	25 pounds ³
30	30 pounds ³
50	50 pounds
60	60 pounds
100	100 pounds
150	150 pounds ^{2, 3}
200	200 pounds ³
250	250 pounds ³
300	300 pounds ^{3, 4}
500	500 pounds ^{1, 2, 3, 4}
600	600 pounds ^{1, 2, 3, 4}
1.	1000 pounds ^{1, 2, 3, 4}
1.5	1500 pounds ^{1, 2, 3, 4}
2.	2000 pounds ^{1, 2, 3, 4}
2.5	2500 pounds ^{1, 2, 3, 4}
3.	3000 pounds ^{1, 2, 3, 4}
5.	5000 pounds ^{1, 2, 3, 4}
6.	6000 pounds ^{1, 2, 3, 4}
10.	10,000 pounds ⁵
15.	15,000 pounds ⁵
20.	20,000 pounds ⁵
25.	25,000 pounds ⁵
30.	30,000 pounds ⁵
50.	50,000 pounds ⁵
60.	60,000 pounds ⁵
100.	100,000 pounds ⁵

1) No lb-oz display for this capacity in standard resolution.

2) No lb-oz display for this capacity in precision resolution.

3) No lb-oz display for this capacity in super precision resolution.

4) No grams display for this capacity.

5) Pound - kilograms display only at this capacity

Calibration Menu

CAL	Zero Calibration Mode.
0	Calibration Zero Press ZERO to perform calibration of the scale zero. Successful calibration is indicated by " donE "

NOTE: The scale will automatically adjust the offset and gain to compensate for dead load and span. When making these adjustments, the scale may ask you to repeat zero calibration immediately after performing a zero calibration or after a span calibration. Successful calibration is indicated by "**donE**"

CAL	Span Calibration Mode. (Does not appear if CAL 0 is not activated.)
FS	Full load calibration.
0.5	Half capacity calibration.
0.25	Quarter capacity calibration.
0.1	1/10th of capacity calibration.
XXXXXX	By pressing the UNITS button first and then the OVER or UNDER buttons, any weight value can be dialed in for calibration. NOTE: "XXXXXX" will be the dialed in weight value.

* **NOTE:** For maximum accuracy, Doran Scales recommends that all scales be calibrated at full capacity. When location or installation make it difficult to bring full capacity weights to the scale, calibration with as little 10% of capacity is possible.

Digital Filter Setup Menu

Avg	Averaging mode Determines the number of samples to average
A0	Stabil-izer © auto averaging. All readings are averaged. Display updates 10 times a second.
A9	Stabil-izer © auto averaging. All readings are averaged. Display updates 9 times a second.
A7	Stabil-izer © auto averaging. All readings are averaged. Display updates 7 times a second.
A6	Stabil-izer © auto averaging. All readings are averaged. Display updates 6 times a second.
A5	Stabil-izer © auto averaging. All readings are averaged. Display updates 5 times a second.
A4	Stabil-izer © auto averaging. All readings are averaged. Display updates 4 times a second.
A3	Stabil-izer © auto averaging. All readings are averaged. Display updates 3 times a second.
2	Fixed averaging 2 readings are averaged. Display updates 20 times a second.
4	Fixed averaging 4 readings are averaged. Display updates 10 times a second.
8	Fixed averaging 8 readings are averaged. Display updates 5 times a second.
16	Fixed averaging 16 readings are averaged. Display updates 3 times a second.
32	Fixed averaging 32 readings are averaged. Display updates 1½ times a second.

Automatic Zero Tracking Setup Menu

AZt	Automatic Zero Tracking Range Small weights within the specified number of divisions are automatically zeroed.
oFF	Zero tracking is off. No automatic zeroing.
0.5	Zero tracking to within 0.5 division.
1 *	Zero tracking to within 1.0 division.
3 *	Zero tracking to within 3.0 divisions.

* **NOTE:** The Legal for Trade mode disables some options and selections listed above. These items have been indicated by an asterisk.

Motion Aperture Setup Menu

m.A. *	Motion aperture * Determines how many divisions consecutive readings must change before the scale is considered to be in motion.
1	1 division change must be seen to enter motion.
3	3 division change must be seen to enter motion.
5	5 division change must be seen to enter motion.

Start Up Zero Setup Menu

SU0 *	Start Up Zero Controls the start up zero status.
on	Zeros on the first stable reading on power up.
oFF	Loads the calibration zero for zero reference

* **NOTE:** The Legal for Trade mode disables some options and selections listed above. These items have been indicated by an asterisk.

Latching Zero Request Setup Menu

Zod	Zero on Demand Enables or disable zero latching.
on	If ZERO is pressed, it is saved until the scale becomes stable.
oFF	If the scale is in motion, the zero request is discarded.

Latching Print Request Setup Menu ‡

Pod	Print on Demand Enables or disables print latching.
on	If PRINT is pressed, the print request is saved until the scale becomes stable.
oFF	If the scale is in motion, the print request is discarded.

Printer Data Output Setup Menu ‡

d.o.	Data Output Mode Determines when serial data will be sent.
t.o.d.	Transmit on demand. Print when the PRINT button is pressed.
C.P.	Continuous Print. Print when display is updated.
A.P.1	Auto Print 1. Print once only when scale goes stable.
A.P.2	Auto Print 2. Print once only when scale goes stable. Scale must return to zero before it can print again.

Output Formats Setup Menu ‡

For.	Data Input / Output Format Defines the appearance of the serial data sent.
F0	Basic output format. (See the Data Communication section for details)
F1	Enhanced Output includes Checkweigh status.
d0	Basic Dual Print Format. Includes Kilogram weight.
d1	Basic Dual Print Format. Includes Kilogram weight and Checkweigh status.
SS0	Basic Output for Doran Model SSP printer.
SS1	Enhanced Output for Doran Model SSP printer.

Baud Rate Setup Menu ‡

br.	Baud Rate Setup Determines baud rate for serial data.
12	1200 baud (bits per second)
24	2400 baud (bits per second)
48	4800 baud (bits per second)
96	9600 baud (bits per second)
14.4	14,400 baud (bits per second)

Print Buffer Activation Menu ‡

bUF ****	Buffer Status Enable or disable print buffer. (RS232 commands change when active.) (RAM needed)
on	Buffer is on. Printer data is printed to memory. Buffer is dumped with the dump command
off	Buffer is off.

Print Buffer Address Menu 1 ‡

Adr.**	Buffer Address Input Print Buffer / RS485 command address.
X	ZERO button scrolls through least significant digit of address.

Print Buffer Address Menu 2 ‡

Adr.**	Buffer Address Input Print Buffer / RS485 command address.
XX	ZERO button scrolls through most significant digit of address.

Serial Data Handshaking Setup Menu ‡

HS***	Serial Data Output Handshaking Selects the type of serial data handshaking used. (See the Data Communication section for details)
oFF	No handshaking is used. Data is sent when ready, receiving device (printer) must be fast enough to keep up with the data.
SF	Software handshaking. Data is sent when ready. Transmission can be controlled by the receiving device. The software handshaking option activates Bi-directional RS232 communications. Refer to the communications section for details. (See Table 2 for Serial Commands)
CtS	CTS Handshaking (Hardware). Data is sent only when CTS is active.

NOTE: Activating the print buffer causes some of the options in the 4300 calibration menu to appear. These items have been indicated by **. Other menu items disappear when the buffer is activated. These items have been indicated by ***. RAM option is needed to activate the Print Buffer, ****.

Units Conversion Setup Menu ‡

CSL	Convert Select Modes Determines which unit selections will be active.
CA *	Convert All. lb, kg, g, oz and lb-oz are active.
Lgo	lb, kg, g and oz are active.
Lh	lb and kg are active.
Lo	lb and oz are active.
go	g and oz are active.

* **NOTE:** The Legal for Trade mode disables some options and selections listed above. These items have been indicated by an asterisk.

Start Up Units Selection Menu ‡

Units	Start Up Units Select Mode Configures selection of start up units.
	Press ZERO to scroll through the units activated in the CSL parameter. The selected units will be displayed on the units indicators to the right of the display.

NOTE: If an invalid start up unit is selected for a given capacity, the scale will automatically change the unit setting to a valid unit when exiting the setup menu.

TIP: Start up units may be set without using the setup menu. While in the weighing mode, select the desired start up units. Switch the scale into the setup/calibration mode by pressing S1. Press S1 again to return to the weighing mode. The scale will now power up in the desired units.

Push-button Function Setup Menu ‡

P.b.	Push Button Configures the active push button functions.
CPt	UNITS, PRINT, OVER, and UNDER enabled
Pt	PRINT, OVER, and UNDER enabled
oUC	UNITS, OVER, and UNDER enabled
oU	OVER and UNDER enabled
CP	UNITS and PRINT enabled
P	PRINT enabled only
C	UNITS enabled only
non	UNITS, PRINT, OVER, and UNDER disabled

NOTE: ZERO button is always enabled.

Remote Push-button Configuration Menu ‡

r.P.b.	Remote Push Button Configures the remote switch to perform one of the three front panel functions.
off	The remote switch is disabled.
P	The remote switch functions as a PRINT button.
C	The remote switch functions as a UNITS button.
0	The remote switch functions as a ZERO button.

Password Protection Activation Menu

P.uu.	Password Enable or disable password protection for limit entry and configuration menu.
off	Password is off.
on	Password is on. Password must be entered before data entry is permitted.

NOTE: Activating password protection causes some of the options in the 4300 calibration menu to appear. These items have been indicated by ‡ ‡ ‡.

Checklimit Entry Mode Menu ‡

C.E.	Checklimit Entry Selects the limit entry mode for check limits
SCR	Value entered via scrolling with OVER or UNDER buttons. (starts scrolling at previously entered value)
SCS	Value entered via scrolling with OVER or UNDER buttons. (starts scrolling at current weight on the platform)
Pb	Value entered by single press of OVER or UNDER button. (current weight on the platform)

Checkweighing Operation Menu ‡

C.o.	Operating mode Activates the Legal for Trade mode.
oUA	Over, under, and accept check weighing.
off	Check weighing is off.
5 b	High, over, accept, under, and low check weighing.

Legal For Trade Setup Menu

oP *	Operating mode Activates the Legal for Trade mode.
Std	Standard operation
44	Legal for Trade, Handbook 44 compliant.
Can	Legal for Trade, Canadian W&M compliant.

* **NOTE:** The Legal for Trade mode disables some options and selections listed above. These items have been indicated by an asterisk.

Scale Resolution Setup Menu

CtS	Counts select
3	Standard precision mode (3000d typ.)
P	Precision mode (5000d typ.)
SP	Super precision mode (10,000d typ.)

NOTE: For maximum accuracy, Doran Scales recommends that all scales be calibrated at full capacity. When location or installation make it difficult to bring full capacity weights to the scale, calibration with as little as 10% of capacity is possible.

Password Entry Menu **###**

E.P	Enter new password
no	Password entry is not activated when UNITS is pressed.
YES	When the UNITS button is pressed, the ENT. Cd. prompt appears. Enter the password and press ZERO to accept. Pressing ZERO without pressing and numbers clears the code. The factory default password is zero.

Raw Counts Display Mode

Raw Counts	Displays the raw Analog to Digital converter data.
	Press ZERO to exit Raw Counts. The raw counts utilizes the filter selected in the AVG set up menu.

Configuration Mode Exit Menu ‡‡

donE	Exit Configuration Menu.
n	Do not exit menu. Start over at the top of the parameter list.
Y	Exit Configuration menu. Save all parameter changes. The 4300 will return to normal weighing when UNITS is pressed.

Data Communications

Introduction to Data Communications:

In the Model 4300 data is sent to a printer or computer by using "asynchronous serial data communications." Data is broken up and sent one piece at a time to the printer or computer. In spite of this apparent simplicity, a basic understanding of serial data communications is needed when setting up the scale.

The scale transmits letters and numbers to a printer or computer by replacing the letter (or number) with an eight bit ASCII code. This code is then transmitted, one bit at a time, to a printer or a computer. A bit is the smallest unit of data and can have a value of "1" or "0". By combining eight bits into a byte, it is possible to get 256 unique bit patterns. These patterns are used to create the ASCII codes used by the scale to represent letters and numbers.

When setting up a serial communications system, there are several concerns that affect the configuration of that system. These are:

- Transmission rate
- Knowing when data starts and stops
- The ability of the receiving equipment to digest the data sent

The transmission rate determines how fast the data is sent from the scale to the printer (or computer) and is measured in Baud or bits per second. (For applications such as the Model 4300, Baud and bits per second are interchangeable.) The transmission rate controls how many bits can be sent in a given time. It is important that the sending and receiving units are set to the same Baud settings. Typical values are 1200, 2400, 4800 and 9600 baud.

The term "asynchronous serial data communications" implies that the sending unit has no way of telling the receiving unit when a data bit has been sent or when to expect the next bit. To correct this problem, both the sending and receiving units use the baud rate setting to determine how fast data should be sent. If the baud rates at the sending and receiving units differ, the receiving unit will expect data to arrive at a different time than when the transmitting unit sent it. When this happens, data will be lost. When the baud rates match, the receiving unit has no problem with the data arriving early or late. The only problem is knowing when the data transmission started.

The scale and the equipment connected to it resolve this dilemma by sending a "start bit" at the beginning of each data byte. This bit tells the printer or computer that a new data byte is on the way. When the start bit is received, the bit timer starts running and runs until it has received the correct number of bits.

The number of bits sent by the scale is controlled by the data bits, parity and stop bit configuration. The scale is factory set for eight bits, no parity and one stop bit. This means that the eight bits following the start bit will be data, followed by a stop bit. The

stop bit signals the end of the data and permits the bit timer a chance to reset itself before the next data byte is sent. No parity bits are sent.

In many cases, the receiving unit is a slow printer with limited memory. In these cases, more data may be sent than the printer can use. Again, data may become lost or scrambled. To prevent this from happening, "Handshaking" is used. When the receiving unit is busy or incapable of receiving further data, it activates the handshaking; telling the sending unit to stop transmission. Then, whenever the receiving unit is ready for more data, it deactivates the handshaking and data transmission continues.

The scale offers hardware and software handshaking. Hardware handshaking makes use of the CTS (clear to send) input on the unit. When this signal is active, the scale is permitted to send data. When the receiving unit is busy, the CTS line is deactivated and the scale stops sending data. When the receiving unit is ready for more data, the CTS is reactivated and the scale will finish sending the data string it was sending when transmission was interrupted. All readings created while transmission is halted are discarded.

Software handshaking relies on bi-directional communications to send the XON (Ctrl-Q) and XOFF (Ctrl-S) flow control characters. The scale has limited bi-directional serial communications to support software handshaking. When a "Ctrl-S" is received, the transmission of data is halted until a "Ctrl-Q" is received. To use this mode, the RTX line of the scale is tied to the TXD line of the receiving unit.

RS485

The 4300 offers an RS485 data communications option. RS485 communications are similar to RS232 except the RS485 provides better noise immunity and it will allow multiple scales to be attached to the same serial cable.

RS485 achieves its performance advantage over RS232 by utilizing a different input and output. In other words, the RS485 device sends two copies of its own data; one in positive logic and in negative logic. The receiving device looks at the two outputs and takes the difference between them. If the difference is positive the bit is "1" if it is negative, it is a "0".

The ability of RS485 to have multiple devices attached to the same line complicates the serial communications solution. Because of the multiple device capability, each device must have a unique dedicated address. Also, no device is permitted to talk unless it has been specifically requested to talk by the master serial bus controller.

Since the 4300 with RS485 may not speak unless spoken to, a print buffer is needed to store scale data until it is requested. This buffer is included as part of the RS485 option. When in the RS485 operation mode, all print requests are redirected to the print buffer rather than the printer port. All scale readings accumulate in the buffer until a buffer print command is received, the scale takes control of the serial bus and transmits the stored scale readings. When the buffer is empty, the scale releases the bus and becomes a listener again.

To activate the RS485 option in the 4300, the scale must have the optional RS485 bus driver and optional Print Buffer RAM installed. Once these are installed, activate the print buffer from the setup menu and then assign a bus address to the scale.

NOTE: When installing a 4300 on a RS485 system, it may be necessary to use termination resistors. The 4300 has three termination resistors built in the main board. Consult your authorized Doran Scales dealer or the factory for more details.

Printer Modes:

The Model 4300 offers four different print control modes. These modes dictate when printer data is sent.

Transmit on demand (tod):

In this mode, scale data is transmitted whenever the print button is pressed, the remote print button is pressed, or a print request is received from the serial port. The scale must be stable and the scale value must be valid before the data is printed.

Continuous print (CP):

In continuous print, data is transmitted each time the scale has a reading ready. Readings which occur when the scale is in motion are called out by the abbreviation "MOT." following the data.

Auto Print 1 (AP1):

Auto Print 1 transmits the first scale reading after the scale leaves motion. The reading must be stable and must be a valid reading before it can be sent.

Auto Print 2 (AP2):

Like Auto Print 1, Auto Print 2 transmits the first scale reading following the scale leaving motion. In Auto Print 2, no further readings will be sent until the scale returns to displayed zero. The reading must be stable and must be a valid reading before it can be sent.

Data Output Format:

In order for the serial data sent from the scale to be useful, the data must be organized so that it is easy to read. To accomplish this, the scale arranges the displayed data with additional text to indicate the active units and to indicate the presence of motion during the reading.

"F0" Format: The basic data format sent by the scale is illustrated in Table 2. Each line of data begins with an STX character (start of text) followed by a polarity sign, which indicates the reading polarity. Next, the displayed data is sent. Six digits are used with a decimal point inserted in the correct position. After the weight data is sent, a space followed by the units are added to the string. When motion is present, another space is inserted followed by "MOT." The string is then finished by adding a carriage return and a line feed.

In the case of lb-oz data, the pounds value is placed after the polarity sign. A space followed by "lb" and another space follows the pounds data. Ounce data is then sent with a decimal point inserted where needed. Once again a space is inserted after the weight data followed by "oz." Only six digits are sent in the lb-oz mode so the allocation of these digits depends on the ounces resolution.

"F1" Format: The "F1" format is a more advanced version of the "FO" format. In this format, the OVER, UNDER, or ACCEPT status is included.

"d0" Format: In the "DUAL PRINT" format, the current weight is first printed using the "F0" format. Then the weight is recalculated in kilograms and is sent as a second line of text. The kilogram data follows the "F0" data format except where parentheses are placed after the STX character and before the carriage return, line feed. Refer to Table 2 for details.

"d1" Format: The "d1" format is a more advanced version of the "dO" format. In this format, the OVER, UNDER, or ACCEPT status is included.

"SS0" format: The data string produced by the SSP format allows the scale to communicate with the Doran Model SSP Label Printer. This printer allows the creation of custom labels containing weight information, bar codes and graphics. Refer to Table 2 and Fig. 9 for details.

"SS1" format: The "SS1" format is a more advanced version of the "SSO" format. In this format, the OVER, UNDER, or ACCEPT status is included. Refer to Table 2 for details.

NOTE: Dual print format: The dual print modes provide the 4300 with the ability to print the current scale reading followed by the equivalent value in Kilograms.

Command (RXD)	Scale output Response (TXD)	Description
W (hex 57)	<p><STX><xxxx.xx><SP><uu><SP><MOT><LF><CR> or <STX><xxxx.xx><SP><uu><SP><AUO><SP><MOT><LF><CR> or <STX><xxxx.xx><SP><uu><SP><MOT><LF><CR> < (><xxxx.xx><SP>< kg)><LF><CR> or <STX><xxxx.xx><SP><uu><SP><AUO><SP><MOT><LF><CR> < (><xxxx.xx><SP>< kg)><LF><CR> or <LF><FR"43SS0"><LF><?><LF><xxxx.xx><LF><uu><LF><P1><LF><00h><00H> or <LF><FR"43SS1"><LF><?><LF><xxxx.xx><LF><uu><LF><AUO><LF><xxxx.xx><LF><KG><LF><P1><LF><00h><00H></p>	<p>"<u>FD</u>" standard format, Prints current weight and units. "<u>F</u>" enhanced format, Prints current weight and units with Accept, Under, Over status. "<u>FD</u>" dual print format, Prints current and kg weight resolution. "<u>FD</u>" dual print format, Prints current and kg weight resolution with Accept, Under, Over status. "<u>5D</u>" Basic Label printer format, for Eltron printers "<u>5S</u>" Enhanced Label printer format, for Eltron printers. dual print format, Prints current and kg weight resolution with Accept, Under, Over status.</p> <p><xxxx.xx> weight data (fixed field of 6 digits plus decimal and polarity "-" or " ", or "-----" for overload, underload, gross underload, or gross overload. Displayed weight. Kilogram weight. <uu> current units. <AUO> Accept, Under, Over status. <SP> line space (hex 20h) <MOT> motion status ("MOT." or " ") (hex 83h) <STX> Start of text (hex 02h) <LF> line feed (hex 0Ah) (control-J) <CR> carriage return (control-M) (hex 0Dh) <?> Prints a "?" <P1> Prints a "P1" <FR"43SS0"> Prints a "FR"43SS0" <FR"43SS1"> Prints a "FR"43SS1" <00h and 00H> Does not print < (> Prints " ("
 < kg> Prints " kg)"</p>
U (hex 55)		<u>Scale changes units</u>
Z (hex 5A)		<u>Zeros scale</u>
XON (hex 11, ctrl-Q)		<u>Turns on serial handshaking</u> scale output disabled
XOFF (hex 13, ctrl-S)		<u>Turns off serial handshaking</u> scale output enabled

Table 2: Doran serial protocol

Specifications and Interconnect Data

Specifications:

Model 4300	
Resolution:	10,000d in super precision mode
Sensitivity:	0.5 μ V min.
Load Cell Capacity:	0.5 mV/V to 3.5mV/V
Power Supply:	115/230 VAC 50/60 Hz
Display:	6 digit LED. 0.56" high
Displayed units:	lb, kg, oz, g, and lb-oz
Capacities:	5lb to 100,000lb
Printer Interface:	Bi-directional RS-232 standard RS485 optional
Calibration	Unit may simply be calibrated with 10%, 25%, 50%, or 100% of capacity. An advanced feature will allows the ability to dial in any weight within capacity.
Controls:	Rugged Polycarbonate touch panel with built in ZERO, PRINT, UNITS, OVER, and UNDER switches.
Construction:	Rugged stainless steel NEMA 4/4x construction.
Options:	Dual Print permits weight printing in current units and kilograms. User configurable remote switch. Optional print buffer.

Interconnect Data:

PIN #	TITLE	DORAN COLOR CODES
1	Chassis Ground (not on connector)	NA
2	+ Load Cell Signal	Red
3	- Load Cell Signal	White
4	+ Sense Signal	Blue
5	- Sense Signal	Brown
6	+ Load Cell Excitation	Green
7	- Load Cell Excitation	Black
8	Chassis Ground (not on connector)	NA

Table 3: Load Cell Connections (TB1)

NOTE: When connecting the load cell, be sure to install the ESD and EMI protection inductor. Refer to Fig. 4 for details.

4 wire load cell: Place a jumper between pins 4 & 6 and a jumper between pins 5 & 7.

PIN #	TITLE
1	CTS for Hardware Handshaking RTX for Software Handshaking
2	TXD
3	Remote Switch High
4	Remote Switch & RS232 Ground

Table 4: Options Connections (P3)

PIN #	TITLE
1	(L) Hot
2	(G) Ground
3	(N) Neutral

Table 5: Power Connections (J4)

PIN #	TITLE
1	Zero Switch Ground
2	Zero Switch High
3	Units Switch
4	Print Switch
5	Over Switch
6	Keyboard Scan
7	Under Switch

Table 6: Keyboard Connections (P4)

Serial Cable Assembly		
DB25 Female connector w/ Software Handshaking		
Function	Pin	Wire Color
TXD	3	Red
RXD	2	White
Signal GND	7	Black
DB9 Female Connector w/ Software Handshaking		
TXD	2	Red
RXD	3	White
Signal GND	5	Black

Table 7: Serial Cable assembly with Software Handshaking

Serial Cable Assembly		
DB25 Female connector w/ hardware handshaking		
Function	Pin	Wire Color
TXD	3	Red
CTS	5	White
Signal GND	7	Black
DB9 Female Connector w/ Hardware Handshaking		
TXD	2	Red
CTS	8	White
Signal GND	5	Black

Table 8: Serial Cable assembly with Hardware Handshaking

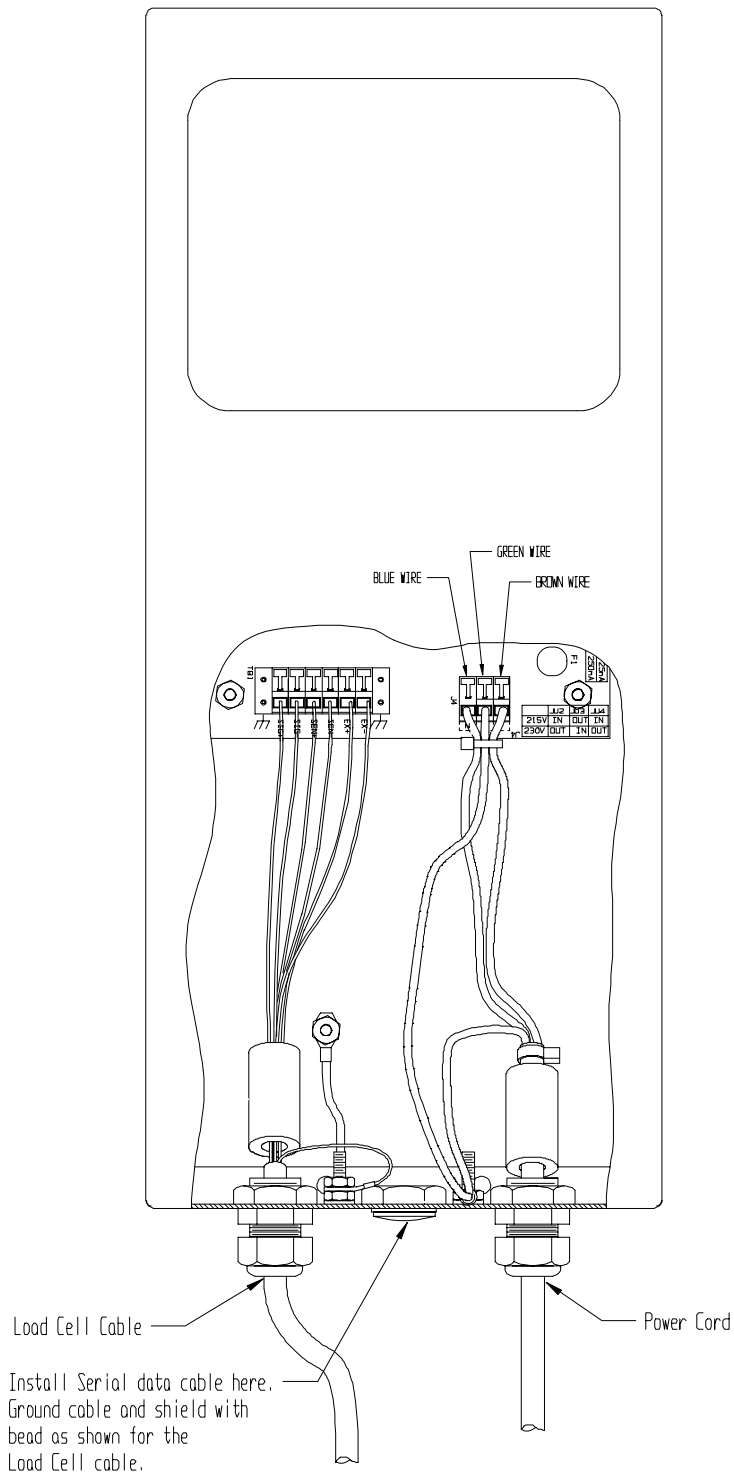

Fig. 4: Installation of EMI / RFI / ESD protection devices.

Troubleshooting

General Problem Resolution:

Problem:	What to Do or Check:
Weight reading will not repeat or scale does not return to zero when weight is removed.	Make sure that there is nothing caught in the platform under or around the load cell or spider interfering with its movement.
Scale overloads early.	Make sure all four corner overload stops are properly set, if present. Take the platter off the scale, invert it and place it back on the spider. With 1/2 of the scale's capacity in test weights concentrated over a corner of the platform, there should be approximately 1/32" of clearance between the stop and the bottom of the spider. Check all four corners then recalibrate the scale. If the problem persists, it is possible that the scale is being shock-loaded causing the load cell to be shifted.
Scale will not indicate full capacity or go into overload.	Make sure that there is nothing caught in the scale under or around the load cell or spider, which would interfere with their movement. If not, check the overload stops using the above procedure.
Scale will not come to zero when the ZERO button is pressed.	Make sure that the scale is stable ("MOT" enunciator is off) when ZERO is pressed. If excessive motion is a problem, then it may be necessary to activate the latching zero feature (ZOd) or lengthen the filter time (Av A32). If the scale is stable, the scale may be set to the Canadian Legal for Trade (4% zero bandwidth). An attempt is being made to zero more than 4% of capacity (see Section "Setup Menus Explained). There may be a problem with the touch-panel or main board. Verify that the ZERO button functions while in the setup mode.
Weight readings don't seem to be correct.	Check the scale's accuracy with a test weight. Recalibrate if necessary.
Scale drifts off of zero.	Check for air currents and/or vibration around the scale. If that is the cause it may be necessary to set the AZT aperture to a wider setting to compensate (see Section "Setup Menus Explained).
Scale reading is bouncing or "flighty".	Check for air currents and/or vibration around the scale. If that is the cause it may be necessary to set the Digital Averaging to a higher setting to stabilize the reading (see Section "Setup Menus Explained).

If you are still experiencing a problem with your scale, or if the problem you are having is not covered in the above list, please contact your Doran Scales authorized dealer.

Resetting the Scale Parameters:

- If at some point the Model 4300, user wishes to return the setup parameters to factory default, follow these steps.

WARNING: Defaulting the scale will require recalibration.

- Remove power.
- Press and hold CAL button (S1) while power is restored.
- The indicator will display "init" until the CAL button is released. After the "init" message is displayed the scale then performs its normal power up routine and enters the Calibration mode. At this time, all the parameters will have been reset to their factory default settings. See Setup Menus Explained section for details on setting up the individual scale parameters.
- Return to the normal weighing mode by momentarily pressing CAL button. The scale will save the revised parameters and will enter the normal weighing mode.

Resetting the Scale:

- In the event that a power problem has disabled the scale, remove power, wait 15 seconds and restore power. The scale should restart and function properly.

Scale Messages:

Message	Meaning
"donE" Function complete.	The scale has successfully completed the requested action.
"Abort" Aborted Function.	The requested action has been canceled prior to completion.
"SAVEd" Parameter value saved.	The scale has successfully store and verified parameter value in nonvolatile memory.
"Ent. Cd." Enter Password	Indicates password mode has been activated and the scale is prompting user for password.

Error Messages:

Error Message	What to Do or Check:
"ovr-Ld" Scale overload	Input from load cell to electronics is outside calibrated limits. Verify platform stops are set correctly and no foreign objects are caught, restraining load cell movement. Remove all weight from the scale and recalibrate.
"udr-Ld" Scale underload	The scale is in underload. The load on the scale is less then the minimum scale capacity by more than -20%. Recalibrate scale or add additional dead load.
"grs-oL" Gross overload	Input into the electronics from the load cell is either too high or too low. Remove all weight from scale. If problem persists, check load cell connections to the scale electronics. Recalibration will not remove this error. This is a hardware error. The load cell may have been damaged. Check all overload stops. Verify that foreign objects are not caught inside the platform. Check for cut or damaged load cell cables.
"grs-uL" Gross underload	The scale is in gross underload. The load exceeds the minimum scale ratings and might result in damage to the scale. Loadcell connections might be wired in reverse. Ignore this message for the first five seconds after power up. See "grs-oL".
"SU 0 E" Startup zero error	The scale was not stable during power up. <u>This error will only occur in Legal for Trade applications.</u> The scale will zero once it becomes stable.

"Er Ad" A/D failure	The scale has detected a failure in A/D circuit. Have scale serviced by a qualified scale repair technician.
"Err EP" EEPROM error	Calibration data and parameter data are corrupted. Reset parameters and recalibrate.
"Er CAL" Calibration error	Calibration data is corrupted. Have scale recalibrated by a qualified scale repair technician.
"Err 1" Program ROM error	The program memory in the scale has become corrupted. Have scale serviced by a qualified scale repair technician.
"Err 2" Buffer memory error.	The memory used for the print buffer has failed self check. Have scale serviced by a qualified scale repair technician.
"Er Cd" Check Limit Error	Check limit values are corrupted. Reset OVER and UNDER limits.
"Ldg 0" Loading zero.	The scale is attempting to load power up zero. This message will remain until scale is stable.
"SPAN Er" Span Error	(During Calibration) Check capacity of load cell. If scale is set to a low % of the load cell capacity there may not be enough signal from the load cell to calibrate the meter. Set capacity of meter to match load cell capacity and recalibrate. Set meter resolution to designated weighing resolution.
"rg. Err" Range Error	(During Calibration) Check capacity of load cell. If scale is set to a low % of the load cell capacity there may not be enough signal from the load cell to calibrate the meter. Set capacity of meter to match load cell capacity and recalibrate. Set meter resolution to designated weighing resolution.



Model 4300

LIMITED WARRANTY STATEMENT

DORAN SCALES, INC. warrants its products to be free from defects in material and workmanship for a period of two (2) years from date of shipment. Any product found to be defective within this time period may be returned to DORAN's factory, freight prepaid, with prior return authorization for repair or replacement at no charge.

DORAN's liability under this warranty is limited to the repair or replacement of the defective product and in no event shall DORAN be liable for consequential or indirect damages to equipment or personnel. Nor shall DORAN be liable for damages to equipment or for personal injury caused by misuse, overload, accidental damage, alteration, improper installation, or unauthorized opening of the equipment. Under no circumstances will DORAN be responsible for any indirect or consequential damages due to errors in weighing or failure of a DORAN product to perform properly.

THIS WARRANTY IS IN LIEU OF ALL OTHER WARRANTIES, EXPRESS OR IMPLIED. THIS WARRANTY CONSTITUTES DORAN'S EXCLUSIVE WARRANTY. THERE ARE NO OTHER WARRANTIES, EXPRESS OR IMPLIED, INCLUDING ANY WARRANTY OF MERCHANTABILITY OR FITNESS FOR A PARTICULAR PURPOSE.

DORAN SCALES, INC.
1315 PARAMOUNT PARKWAY
BATAVIA, ILLINOIS 60510
(630) 879-1200