

# PENNSYLVANIA



Pennsylvania Scale Co.  
1042 New Holland Ave.  
Lancaster PA 17601  
800-233-0473  
[www.pascale.com](http://www.pascale.com)

## INSTRUCTION & SERVICE MANUAL

### 7600E Digital Indicator



## TABLE OF CONTENTS

<b>SPECIFICATIONS.....</b>	<b>3</b>
<b>INSTALLATION.....</b>	<b>4</b>
<b>SETUP ACCESS.....</b>	<b>5</b>
<b>MENU LAYOUT.....</b>	<b>6</b>
<b>CONFIGURATION.....</b>	<b>7</b>
<b>REMOTE SERIAL DISPLAY.....</b>	<b>8</b>
<b>CALIBRATION.....</b>	<b>9</b>
<b>SERIAL PORTS.....</b>	<b>10</b>
<b>SERIAL COMMUNICATIONS.....</b>	<b>11</b>
<b>ANALOG OUTPUT.....</b>	<b>13</b>
<b>DIGITAL INPUT/OUTPUT.....</b>	<b>15</b>
<b>SETPOINTS.....</b>	<b>16</b>
<b>OVER/UNDER.....</b>	<b>17</b>
<b>BATCH MODE.....</b>	<b>18</b>
<b>SERIAL COM. SETPOINT/ACC.....</b>	<b>19</b>
<b>TIME &amp; DATE.....</b>	<b>20</b>
<b>WEIGH IN/OUT.....</b>	<b>21</b>
<b>SMART SERIAL.....</b>	<b>23</b>
<b>ASCII CHART.....</b>	<b>28</b>
<b>DISPLAY MESSAGES.....</b>	<b>32</b>
<b>115/220 VAC.....</b>	<b>33</b>
<b>SPARE PARTS.....</b>	<b>34</b>

## **SPECIFICATIONS**

**Smart Serial Setup:** 8 custom print files plus 8 macro files, 30 characters each.

**Batch Start/Stop:** Control from front panel or remote input.

**Setpoint Operation:** 4 output relays configurable for normal setpoints, over/under or manual/auto batch modes.

## **LOAD CELL A/D CONVERTER**

TYPE: 24 bit delta sigma  
EXCITATION: 5 VDC, 120 mA max.  
SIGNAL INPUT: 16 mv  
SENSITIVITY: 0.1 uV/grad  
UPDATE RATE: 30 update/second

**DISPLAY:** Six (6) Decades, 0.6 inch LED

**KEYPAD:** Full numeric plus controls

**POWER INPUT:** 117/217 VAC, 50-60 HZ, 20 watts, fuse 0.25 A Slo-Blow.

## **SERIAL PORTS:**

**Port 1:** RS232C or 20ma  
**Port 2:** RS485, RS232C or 20mA.

**ENCLOSURE:** Stainless Steel, NEMA 4x, Tilt - Stand Base, 7lbs.

**CASE:** 9" (w) x 6.44" (h) x 4" (d) Tilt or panel mount.

## **OPTIONS:**

**TIME & DATE:** 12/24 hr, battery backed.

**ANALOG OUTPUT:** 0-10v, 4-20ma (16 bit D/A).

**DIO:** 4 AC/DC – inputs, 4 AC outputs (SS Relays, 0.5 amp)

**Optional Case:** 10" (w) x 6.5" (h) x 4" (d) Tilt only.

**Panel Mount:** Kit (replaces tilt stand).

## INSTALLATION

**POWER WIRING:** The indicator is designed to be operated from 117/217 VAC, 50-60 Hz. The unit power cord must be plugged into a grounded 3 - wire polarized AC wall socket. All normal wiring and grounding precautions should be observed, including use of a "clean" AC power line.

**SCALE WIRING:** The unit is equipped with cable gland entry for load cell cable insertion and internal (pluggable) terminal strip for 4 / 6 wire connection. Remove sense jumpers P11-8/7, P11-6/5 for six wire.

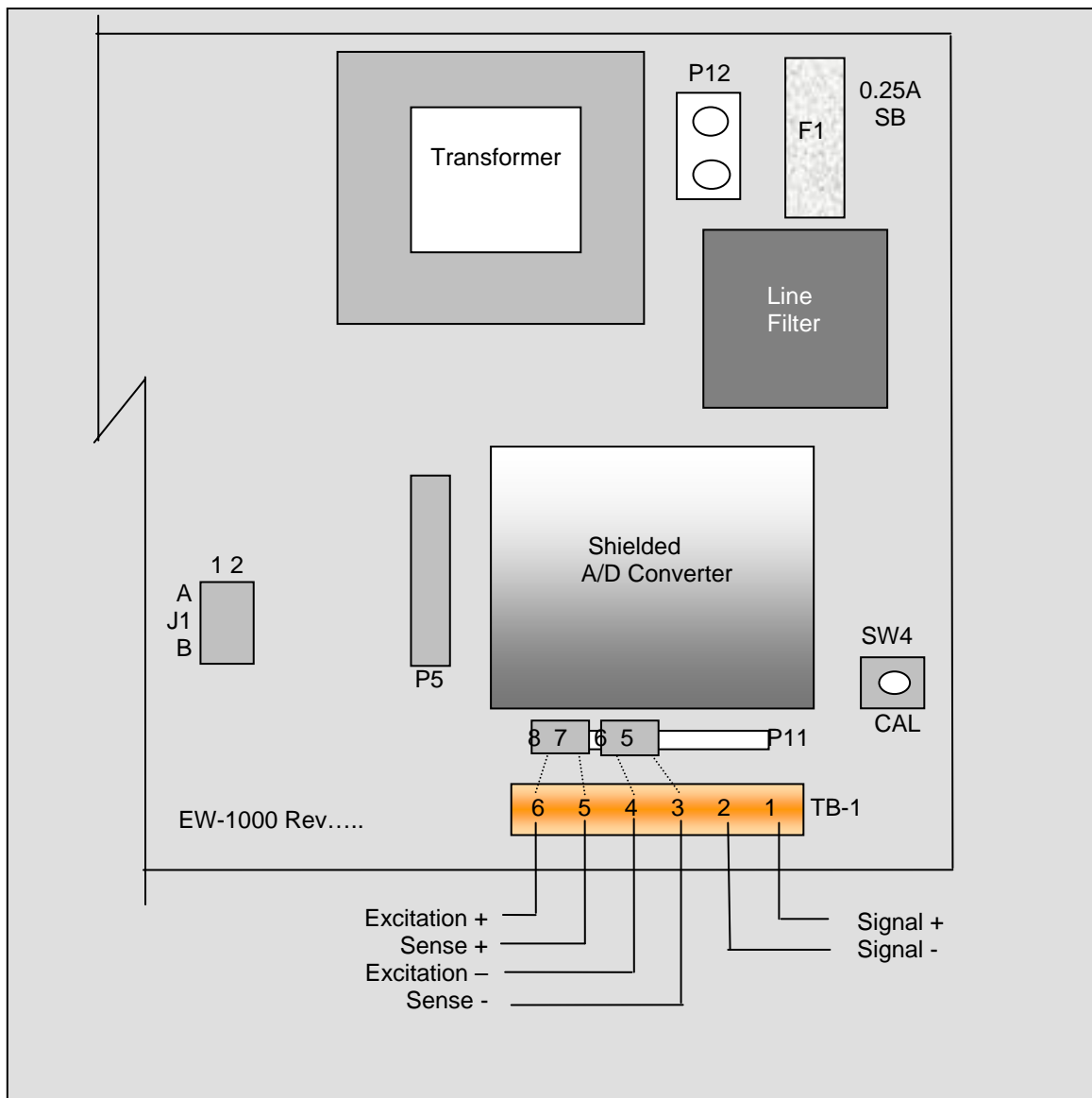



## SETUP ACCESS

To access instrument configuration, calibration or to enable options, depress the “Zero” key for five seconds.

The Audit Trail counters (“Pxxxx” and “Cxxxx”) are displayed first followed by access code request (“AC?”). The initial factory setting is “0000” which can be entered with four steps of the “Gross/Net” key (“AC0000”) and “Print”. If no entry is made, instrument returns to operate mode.

The access code can be changed to any four digit combination during setup exit when display again shows “AC?”.

The “Check” key provides the software version “V 1.XX” followed by the display test routine. Use the “ENT” key to advance to the keyboard test and to exit tests.

After entry, use the “Tare Recall” key to select a main menu; configuration (“SEL.CFG”), calibration (“SEL.CAL”), or options (“SEL.OPX”) and “Start/Stop” to back step.

The “Gross/Net” key enters selected menu and is used to step through sub categories. Individual parameter selection is made with the “Tare/Recall” key, which then steps through the parameter choices (“Zero” key back steps within the menu).

The “ENT” key is used at any point to “back” up from categories to menus and to “save?” and “AC?” and exit.

During the exit steps, if changes were made, the display is “save?” with alternate “no”. To save changes, use the “Units” key to select “yes” and “ENT” to exit. Calibration numeric entries are entered directly followed with the “ENT” key.

**Front panel access is inhibited if conventional “sealing” is applied by setting jumper J1-1 in the B position. The board mounted “CAL” button is then used for access.**

# Menu Layout

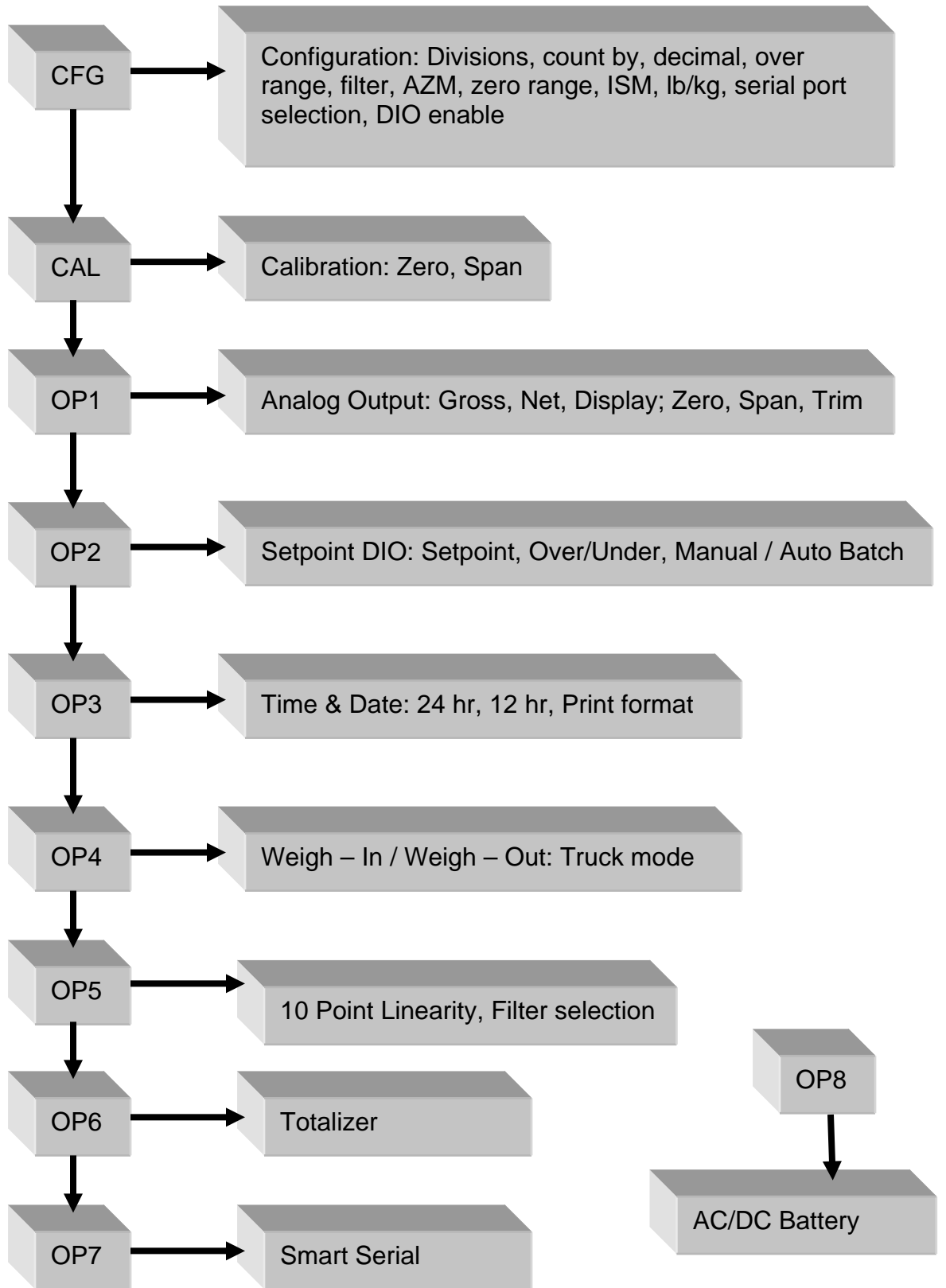

**CONFIGURATION: “SEL.CFG”** Use Gross/Net to enter the menu and step to each category, Tare Recall to select parameters. ENT to return to menu selection.

Capacity is the combination of “1”, “2” and “3”.

Example: 1\_\_100, 2\_\_2 and 3\_\_0.0 = 2,000 x 0.2 lb

Step	Parameters	Definition
1	5, 10, 15, 20...100, 120...1000	<b>Number of divisions x100</b> 100 = 10,000 divisions
2	1, 2, 5, 10, 20, 50, and 100.	<b>Count by selection</b> 10,000 divisions, count by 2 = 20,000
3	0, 0.0, 0.00, 0.000, and 0.0000	<b>Decimal point selection</b>
4	105P, 9 d (105% or 9 divisions)	<b>Overrange selection</b>
5	1, 2, 3, 4, 5, 6, 8, 10, 12, 15.....90	<b>Digital filter selection (averaging)</b>
6	off, 0.5, 1, 3, 5, 10 (divisions)	<b>Auto Zero Maintenance (AZM)</b>
7	1.9, 5, 10, 20, FS (% of capacity)	<b>Zero range selection</b> 1.9% of 2,000 x 0.2 = 38.0 lb
7.1	off, on (ISM)	<b>Zero's scale on power-up</b>
8	off, 1, 3, 5,10 (divisions)	<b>Motion Band selection</b>
9	lb, kg, con	<b>Units selection and convert</b>
10	nt, Gtn, n.nt, n.Gtn.	<b>Port 1 serial output selection</b> nt display only, Gtn is Gross Tare Net and n.nt/n.Gtn inhibit negative gross printing
11	off, co, de	<b>Off, Continuous, or Demand</b>
12	7o, 7E, 8n	<b>7- odd, 7- even or 8- none</b>
13	12, 24, 48, 96	<b>Baud rate selection</b>
14	off, 1, 2, 3, 5, 10, 15 (seconds)	<b>Delay between lines or continuous output.</b>
19	A, b	<b>A : adds “STX” in continuous</b> <b>b : No “STX” in continuous</b>
20	nt, Gtn, n.nt, n.Gtn	<b>Port 2 serial output selection</b>
21	off, co, de, Ln	<b>Off, Continuous, Demand, Network</b>
22	7o, 7E, 8n	<b>7- odd, 7- even or 8- none</b>
23	12, 24, 48, 96	<b>Baud rate selection</b>
24	off, 1, 2, 3, 5, 10, 15 (seconds)	<b>Delay between lines or continuous output.</b>
25	1 – 16 (RS485/RS422)	<b>Network address selection</b>
30	off, on	<b>DIO Inputs</b>

## Remote Serial Display (RSD) Option

In RSD mode the instrument can be set to work with another unit as a “remote” either as the main or the slave unit. Communication is pre-set for channel two only on both units.  
(RS232, 9600, 8, none)

When in remote mode, re-access to the following selections requires using the internal “cal” switch.

Remote unit can have full or partial control of the main unit. Devices are available to replace the cable for wireless communication.

40	rd.OF, rd.En, rd.re	rd.En : Selects Indicator as Remote Display (RSD) rd.re : Allows indicator to operate w/RSD
41	En.On	Allow remote keypad operation
42	Zr.On	Enable/Disable zero key
43	tr.On	Enable/Disable tare key
44	Un.On	Enable/Disable unit key
45		Print function with parameter “11” see below
46	Fn.On	Enable/Disable all other functions

11.P1.xx	45.Pr.xx	RSD Serial Port 1	RSD Print Key
off	off	Disabled	Disabled
off	on	Disabled	Sends print cmd to weigh meter
co	off	Sends co serial	Disabled
co	on	Sends co serial	Sends print cmd to weigh meter
dE	off	Disabled	Disabled
dE	on	See right.....	Outputs demand format from RSD serial port 1



**CALIBRATION: “SEL.CAL”** Use Gross/Net to enter the menu indicated by a flashing “C” on the left and live weight is displayed. Scale zero (dead load) or adjusting span (single or multi-point) are independent. Therefore either can be done and repeated as necessary before exciting calibration. If an error has been made, exit without “storing” will return to prior setup.

KEY (FUNCTION)	DISPLAY	Definition
(Live weight 123 lb)	“C”__123	Cal mode scale reading
Zero (acquire dead load)	“-----“ to “C__0.0”	acquires new dead load
(live weight 5000 lb)	“C”__4995	Scale reading with load

**Enter numeric value directly:**

(Adjustment complete)	005000	adjusted value
-----------------------	--------	----------------

**Then ENT:**

(adjust span)	“-----“ to “C” 5000	displays new span
---------------	---------------------	-------------------

**Repeat as required then ENT to exit CAL**

“Save ?” “No” or “Save ?” “Yes” use Units to select and ENT to store “yes” with changes or “no” to exit without changes.

Continue with ENT to “Ent AC” which allows access code change by entering a new four digit code and ENT or ENT with no entry to maintain current password.

**Option 5** Ten point calibration: Allows up to 10 span points (pt1.....pt10). Zeroing the scale clears the existing values. Points are assigned incrementally with error indication if the addition is not above the prior point or exceeding scale capacity.  
Filter selection included for rolling or box averaging.

5.1	OFF, On	Enable 10 point span
5.2	A, b	A : Rolling average B : Box average

## SERIAL PORTS

Port 1: RS232 duplex (Rx,Tx), 20ma (Tx).

Port 2: RS232 duplex (Rx,Tx), 20ma (Rx,Tx), RS485, or RS422.

Note: Position jumper on J2 for Port 2 receive selection.

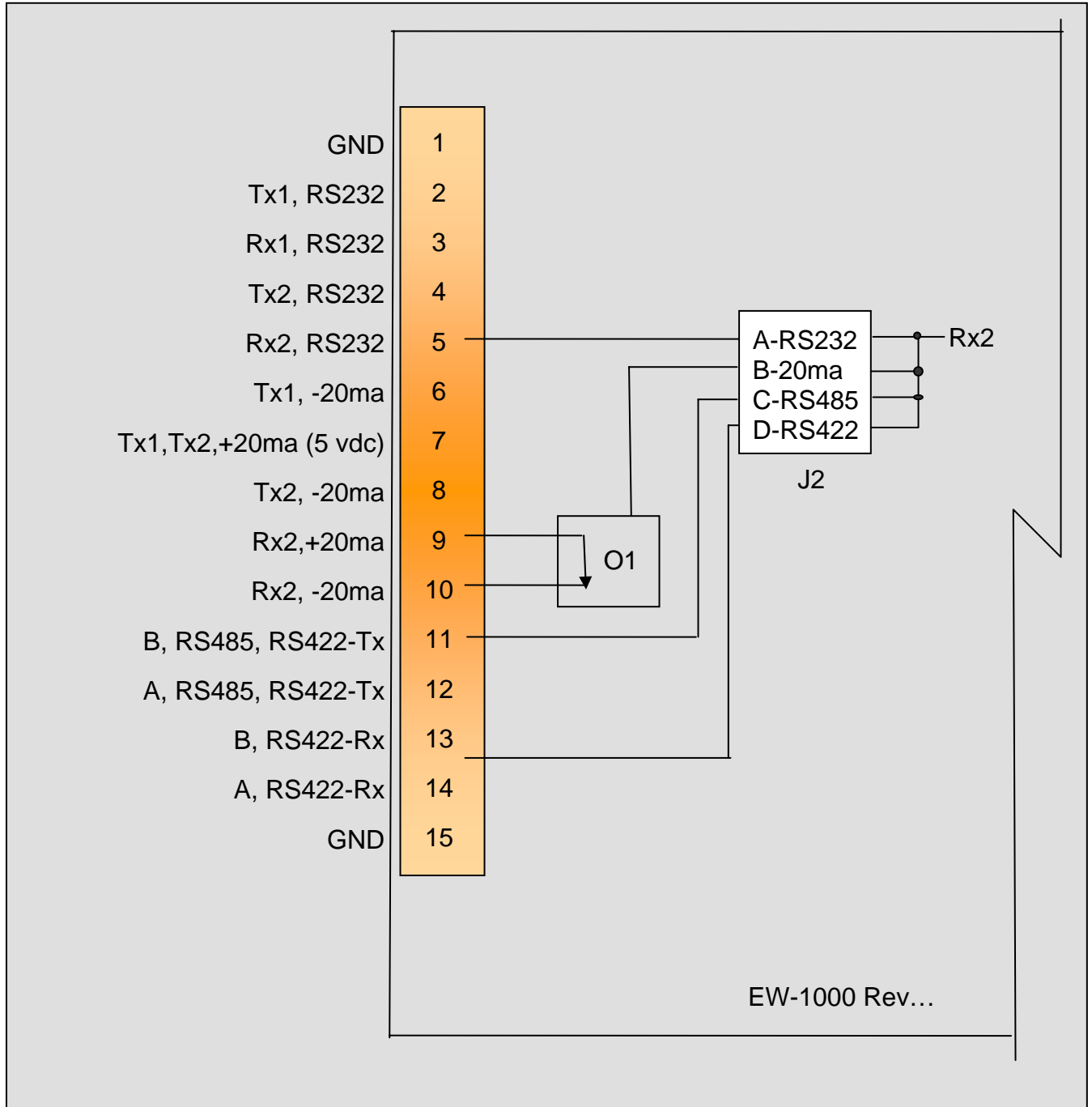

## Serial Communications

### Remote Commands

<Z><cr>	Zero Scale	“Gross” mode, no motion, inside zero range.
<N><cr>	Switch to Net	“Gross” mode with Tare stored.
<G><cr>	Switch to Gross	“Net” mode.
<T><cr>	Auto Tare	Switch to Net, no motion, not at “Gross” zero.
<P><cr>	Print	Valid display, No motion
<U><cr>	Units	Change units

### Data Formats

Demand Mode: <stx><pol><DATA><sp><lb/kg><sp><GR/NT><cr/lf>

Continuous Mode: <stx><pol><DATA><L/K><G/N><status><cr/lf>

Brackets “<>” are not sent

stx: “Start of Text” character (ASCII 002) (can be removed in continuous: config 19)

pol: Polarity sign, “SPACE” (ASCII 032) for positive or (-) sign (ASCII 045) for negative

sp: Space character (ASCII 032)

DATA: Seven (7) digit data field including decimal point or fixed (dummy) zero if selected.  
“Leading Zero Suppression” with leading zeros transmitted as “space” characters.

lb/kg: Two (2) character field data identification for weight units, in demand (printer) mode.

Weight in lb = “lb” (ASCII 108,098), weight in kg = “kg” (ASCII 107,103)

L/K: One (1) character field data identification for weight units in continuous (computer) mode.

Weight in lb = “L” (ASCII 076), weight in kg = “K” (ASCII 075)

GR/NT: Two (2) character field data identification for weighing mode in demand (printer) mode.

Gross Mode = “GR” (ASCII 071,082), Net Mode = “NT” (ASCII 078,084)

G/N: One (1) character field data identification for weighing mode in continuous (computer) mode.

Gross Mode = "G" (ASCII 071), Net Mode = "N" (ASCII 078)

status: One (1) character data identification used in the continuous (computer) output mode to identify the status of the indicator. Characters are listed below in order of priority.

Calibration/configuration	<D> (ASCII 068)
Over/Under Range	<O> (ASCII 079)
Motion	<M> (ASCII 077)
Center of Zero	<C> (ASCII 067)
None of the above	<sp>(ASCII 032)

cr/lf: Two (2) character field, "Carriage Return" (ASCII 013), "Line Feed" (ASCII 010)

### **Guidelines for Serial Output:**

Demand format will inhibit "print" when scale is in "motion" or with negative "Gross" weight, even in "Net" mode (based on setting "CFG 10").

Local Network Protocol:

Command to the indicator:

<\*><DD><00><cmd><data entry><CR>

Response from indicator:

<:><00><DD><cmd echoed><data resp><CR>

Where: (<,> brackets not sent)

*	= Message from master (2AH)
DD	= Indicators address
00	= Master address (fixed at 00)
CR	= Message terminator (ODH)
:	= Response from indicator (3AH)
cmd	= Command to indicator
cmd ech	= Command echoed from indicator
data ent	= Data entered into indicator
data resp	= Data response from indicator

# OPTION 1: Analog Output

0 – 10 Vdc or 4 – 20 ma, select with jumpers J1 and J2

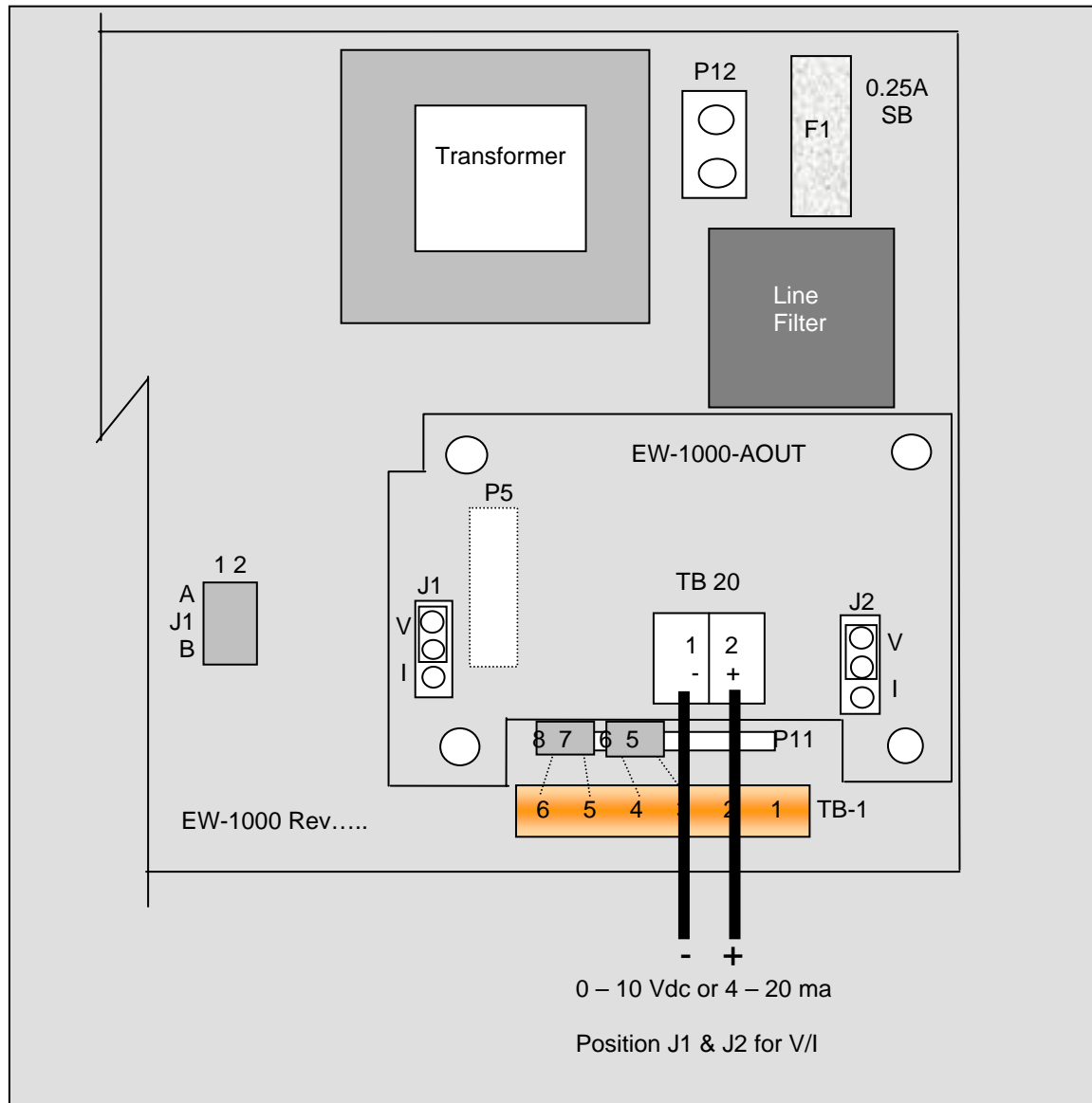

**Option 1 Analog Output:** “SEL.OP1” Use Gross/Net to enter the menu and step to each category, Tare Recall to select parameters. ENT to return to menu selection.

<b>DISPLAY</b>	<b>Parameters</b>	<b>Definition</b>
1.1__Gr	Gr, Net, DSP	Analog tracks gross, net or display

“1.5\_\_Zr” “000” (flashes current analog starting point)

**Adjust value and ENT to adjust starting point.**

“1.6\_\_FS” “500” (flashes current analog span point)

**Adjust value and ENT to adjust full scale.**

1.7\_\_ZrA While monitoring the output, use Start/Stop to decrease, Tare Recall to increase the analog reading (Zero trim digi-pot).

1.8\_\_FSA While monitoring the output, use Start/Stop to decrease, Tare Recall to increase the analog reading (Span Trim digi-pot).

**ENT to exit OP1.**

## OPTIONS 2: DIO

AC Inputs; D1, D2 are not installed, J1 = short (underside), J2 = open, R1 – R4 = 18k (3w, 5%, flame proof).

DC Inputs; D1, D2 are installed, J1 = open (cut trace), J2 = short, R1 – R4 = 1.5k (1/2w, 5%, carbon film). AC Outputs; Solid State Relays, 120VAC, 0.5A.

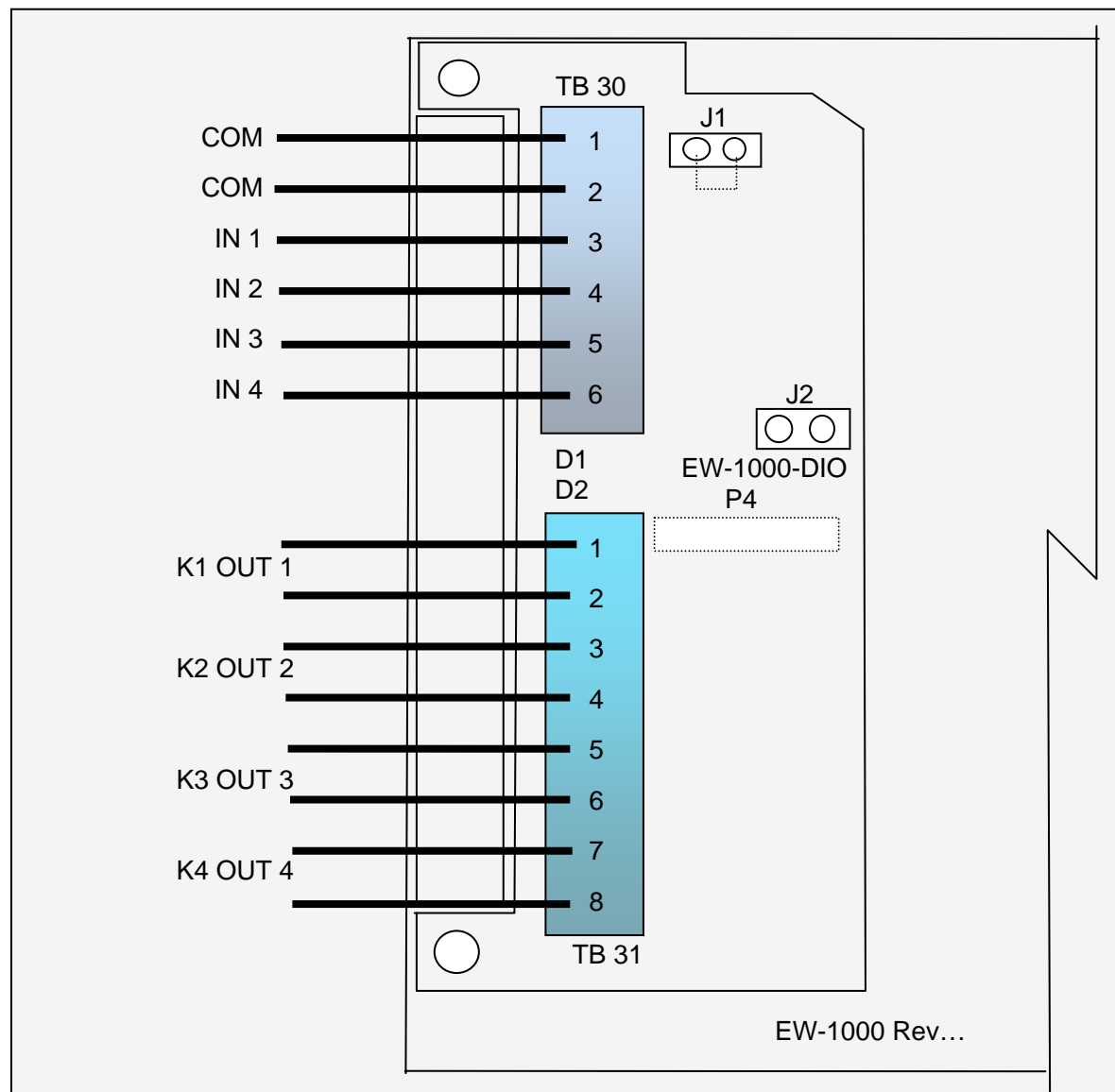

**Option 2 DIO: "SEL.OP2"** First select the operating mode for "Setpoint", "Over/Under", "Manual or Auto Batch". After setup, the parameters for the selection are entered from

the weighing mode.

Use Gross/Net to enter the menu and step to each category, Tare Recall to select parameters. ENT to return to menu selection.

Note: external Inputs are enabled in Configuration with “CFG 30”.  
DIO Inputs can be configured for 120vac, 5vdc or dry contact.

	Normal	Batch	CFG 30 off Batch
IN 1	Gross/Net	Stop	n/a
IN 2	Tare	Start	n/a
IN 3	Zero	Zero	Bypass Ing 1
IN 4	Print	Print	Bypass Ing 2

DIO Outputs are 120vac (0.5 amp) or optional 24 vdc, based on operating mode:

	Dual	Setpt 1	Setpt 2	Ov/Un	Man B	Auto B
Out 1	Setpt1-A	Main 1	Main 1	Low	Main 1	Main 1
Out 2	Setpt1-B	Fast F1	Fast F1	Accept	Fast F1	Fast F1
Out 3	Setpt2-A	Tol	Main 2	High	Main 2	Main 2
Out 4	Setpt2-B	Zero B	Fast F2	Zero	Zero	Fast F2

Checkweigher “Bar” graph legends:

Ck1-3	Out Low	Low	Accept	High	Out High
-------	---------	-----	--------	------	----------

Setpoint values are entered from “Weighing Mode” by the SET key and direct numeric entry.

Weight errors of any kind (e.g., ol, ul, etc) will de-energize all relay outputs and abort a batch if one is in progress.

Four outputs are available to use as two setpoints with main and fast feed, single setpoint main and fast feed plus tolerance and zero band. Also Pre-Act can be applied to the main, for material in-flight compensation.

Step	Parameter	Definition
------	-----------	------------



<b>2.0</b>	<b>OFF, SP, OU.UN, bAt1, bAt2</b>	Mode select: setpoint, over/under (check weighing), Manual Batch, Auto Batch
<b>2.0</b>	<b>SP</b>	Setpoint
<b>2.2</b>	Off, s1, s1.p, s1.d, s.p.d, Dual	Setpoint. 1 + pre-act, + drib, + both, Set1-A&B.
<b>2.3</b>	Gr, nt, dSP, Count	Setpoint 1 tracks Gross, Net, Display, Count
<b>2.4</b>	POS, ZER	Output on below reading (POS), inverted (ZER)
<b>2.6</b>	Off, s2, s2.p, s2.d, s2.p.d, tOL, Dual	Setpoint. 2 + pre-act, + dribble, + both, Tolerance, Set2-A&B.
<b>2.7</b>	Gr, nt, dSP, Count	Setpoint. 2 + pre-act, + dribble, + both
<b>2.8</b>	POS, ZER	Output on below reading (POS), inverted (ZER)
<b>2.10</b>	ZbO	Zero band output (input weight value)
<b>2.11</b>	Off, On	Hysteresis, provides 3 grads to prevent relay chatter
<b>s.p.d</b> example	SP1.trG (Target) = 1000 SP1.PrE (Pre-act) = 5 SP1.drb (Dribble) = 10	Main and Fast Feed are on until reading reaches 990, then Fast Feed turns off and Main continues until Pre-act at 995

<b>2.0</b>	<b>OU.UN</b>	Over/Under – check weighing
<b>2.2</b>	Off, HL, tGt, Ck1, Ck2, Ck3	High/Low band, Target and +/- band, Check Weigher 1-3.
<b>2.3</b>	Gr, net, dSP	Outputs track Gross, Net, Display
<b>2.4</b>	POS, ZER	Invert low
<b>2.5</b>	POS, ZER	Invert accept
<b>2.6</b>	POS, ZER	Invert high
<b>2.10</b>	ZbO	Zero band output (input weight value)
<b>2.11</b>	Off, On	Hysteresis, provides 3 grads to prevent relay chatter
<b>2.12</b>	Off, On	Enables “Bar” graph legends
<b>HL</b> example	Low = 950 High = 1050	Then low is on until 950, then accept is on until 1050 and high is on above 1050.
<b>tGt</b> example	Target = 1000 Low = 50 High = 50	Outputs match above example for HL

Note:	Batch printouts are from Port 1 only	
-------	--------------------------------------	--

<b>2.0</b>	<b>Bat 1</b>	Manual Batch mode, pauses between setpoints
<b>2.1</b>	Prn, tAr, dIn	7400 uses print, tare or external (DIO) for start. Pressing any key other than “start” will pause and a second push will abort. 7600E uses Start/Stop panel switch
<b>2.2</b>	Off, s1, s1.p, s1.d, s.p.d	Setpoint. 1 + pre-act, + dribble, + both
<b>2.3</b>	Gr, nt, dSP, Count	Setpoint 1 tracks Gross, Net, Display, Count
<b>2.4</b>	POS, ZER	Output on below reading (POS), inverted (ZER)
<b>2.6</b>	Off, s2, s2.p, s2.d, s2.p.d	Setpoint. 2 + pre-act, + dribble, + both
<b>2.7</b>	Gr, nt, dSP, Count	Setpoint. 2 + pre-act, + dribble, + both
<b>2.8</b>	POS, ZER	Output on below reading (POS), inverted (ZER)
<b>2.10</b>	ZbO	Zero band output (input weight value), available if S2 dribble not used

<b>2.0</b>	<b>Bat 2</b>	Auto Batch mode, continues without pause
<b>2.1</b>	Prn, tAr, dIn	7400 uses print, tare or external (DIO) for start. Pressing any key other than “start” will pause and a second push will abort. 7600E uses Start/Stop panel switch
<b>2.2</b>	Off, s1, s1.p, s1.d, s.p.d	Setpoint. 1 + pre-act, + dribble, + both
<b>2.3</b>	Gr, nt, dSP, Count	Setpoint 1 tracks Gross, Net, Display, Count
<b>2.4</b>	POS, ZER	Output on below reading (POS), inverted (ZER)
<b>2.5</b>	Off, 1, 2, 3, ....., 10	Time Delay (settling) before print
<b>2.6</b>	Off, s2, s2.p, s2.d, s2.p.d	Setpoint. 2 + pre-act, + dribble, + both
<b>2.7</b>	Gr, nt, dSP, Count	Setpoint. 2 + pre-act, + dribble, + both
<b>2.8</b>	POS, ZER	Output on below reading (POS), inverted (ZER)
<b>2.9</b>	Off, 1, 2, 3, ....., 10	Time Delay (settling) before print
<b>2.10</b>	ZbO	Zero band output (input weight value), available if S2 dribble not used

Relay override command: <RLY> K(1-4) State (0=off, 1=on)  
 <RLY><0> Reset, restore to normal operation.  
 <RLY><3><1> Turn K3 on  
 <RLY><4><0> turn K4 off

**Additional Serial Commands: Setpoint/Accumulator**

Totalizer/Accumulator reset command. Send TC<CR> to reset the totalizer, and the meter responds with a TC+<CR><LF> string.

### Ten/Nine-digit Accumulator Printing/Serial Format Output

COMMAND	Output	Description
TR1<CR>	" 57.85 lb"	10/9-digit w/ printable units (e.g., lb or kg)
TR2<CR>	" 57.85LA"	10/9-digit w/ computer units (e.g., L or K) & A for accumulator.
TR3<CR>	" 57.85"	10/9-digit only
TR4<CR>	"0000057.85"	10/9-digit w/ leading zeros

All transmissions are terminated by a CR & LF.

If there is a decimal-point in the accumulator, nine digits are transmitted.

#### Setpoint Recall:

<S><R><1><CR> Requests value of setpoint 1

<S><R<I><CR><LF> Response if Setpoint 1 is off

<S><R><1><( ><SP><SP><1><0><0><0>< )><CR><LF> if setpoint = 1000

#### Setpoint Entry:

<S><E><1><( ><1><0><0><0>< )><CR>

#### Full-Duplex Setpoint Parameter Entry/Recall

	1	2	3	4	5	6
Setpoint	SP-1			SP-2		
Setpt-Preact	SP-1	Pr-1			Pr-2	
Setpt-Drib	SP-1		Dr-1			Dr-2
Stpt-pr-dr	SP-1	Pr-1	Dr-1		Pr-2	Dr-2
Stpt-dual	SP-1-A		SP-1-B	SP-2-A		SP-2-B
Output	K1		K2	K3		K4

OP3	Time & Date	
3.1	---, 24H, 12A, 12P	Skip time, 24 hour, 12 hour am, 12 hour pm

<b>3.2</b>	T1	Set time: hh mm ss
<b>3.3</b>	dA	Set date: mm dd yy
<b>3.4</b>	S.no, no, Let	Month print selection, short numerical (mm/dd/yy), number 01 thru 12, month spelled out
<b>3.5</b>	Off, Un, Ab, On	Print under, above or on the same line

<b>OP4</b>	Weigh – In / Weigh - Out	See page 19
<b>OP5</b>	10 Point Linearity	On, Off see page 9
<b>OP6</b>	Totalizer	
<b>6.1</b>	Off, On, AU	Enable Totalizer (operates with Batch or Print) AU: Auto accumulates/prints stable weight
<b>6.2</b>	Off, 1.....50	Totalizer reset band

**Option 6 Totalizer:** Operates with “print” function in normal mode or batch mode.

In normal mode, current value is added to the totalizer with each “Print” command. The reset band is used to inhibit a double add when not in Batch Mode.

View the Total with the “2” key and during the display (AC..XXXX), the “Print” key is used to print the total, the “Ent” key returns to weigh mode.

The “Clear” key is used to clear the totalizer by first changing the message from “Clr.ACC...no” to “Clr.ACC...yes” with the “Units” key and “Ent” to complete. A “Cleared” message is provided for conformation.

Note: Totalizer works with port 1 only and the “Print” key is disabled when Batch Mode and Totalizer are both enabled.

#### **OPTION 4: Weigh – In / Weigh – Out**

Truck Scale Application: Provides six digit Identification.

Operates in “Gross” only.

This mode provides a system for single scale applications to determine net weight by storing incoming weight and completing the transaction with out going weight.



4.1	Off, On	Turn on Weigh-in / Weigh-out
4.4	1, 2	Select print port 1 or 2
4.5	8n1, 7e1, 7o1	Data setup, 8 bit no parity one stop, 7 bit even one stop, 7 bit odd one stop
4.6	1200.....9600	BAUD rate selection
4.7	Off, 1, 2, 3	Line feed delay

Note: Print format based on smart serial setup or unlabeled default. Truck ID cannot be accessed unless there are (min) five grads of weight on the scale.

### Full Truck IN

Truck enters scale full, scale indicates “Stable”.

Operator inserts ticket and pushes "Print" key.  
Display responds with "Id no" prompt.  
Operator enters truck "ID Number", up to 6 – digits.  
Operator pushes "Ent" key.

Printer prints:       Time/Date (optional)  
                          (xxxxxx) ID. NO.  
                          (xxxxxx) lb GR

Truck goes to empty load.  
Empty truck returns to scale, scale indicates "Stable".  
Operator pushes "Print" key and "Id no" prompt appears.  
Operator enters same ID Number as previously printed.  
Operator pushes "Ent" key.

Printer prints:       Time/Date (optional)  
                          (xxxxxx) ID. NO.  
                          (xxxxxx) lb GR Recalled  
                          (xxxxxx) lb TR  
                          (xxxxxx) lb NT

### **Empty Truck IN**

Truck enters scale empty, scale indicates "Stable".  
Operator inserts ticket and pushes "Print" key.  
Display responds with "Id no" prompt.  
Operator enters truck "ID Number", up to 6 – digits.  
Operator pushes "Ent" key.

Printer prints:       Time/Date (optional)  
                          (xxxxxx) ID. NO.  
                          (xxxxxx) lb GR

Truck goes to fill load.  
Full truck returns to scale, scale indicates "Stable".  
Operator pushes "Print" key and "Id no" prompt appears.  
Operator enters same ID Number as previously printed.  
Operator pushes "Ent" key.

Printer prints:       Time/Date (optional)  
                          (xxxxxx) ID. NO.  
                          (xxxxxx) lb GR  
                          (xxxxxx) lb TR Recalled  
                          (xxxxxx) lb NT

**Transaction Buffer: Select / Print / Clear / Clear All**

Select ID:	With "ID" displayed, user can select a stored ID by pressing "Set" (up) or "Start/Stop" (down) to scroll through the buffer.
Print Buffer:	Pushing Gross/Net with ID displayed will cause output of the complete buffer ( ID with Tare).
Clear ID:	Pushing clear with ID displayed will clear that ID and step to the next.
Clear ALL:	With "ID", holding the clear switch will prompt "Rec.Clr" and using unit to switch to "yes" and enter will clear entire buffer.

### Option 7: SMART SERIAL I/O

The SMART SERIAL I/O option now offers a wide degree of flexibility for an operator to customize the serial output format for individual system requirements. The custom print currently supports:

- Specifying starting and terminating characters (**stx**, **cr**, **lf**, etc.).
- Adding printer control characters.
- Custom **headers**, **titles**, etc..
- Customized parameters such as "**GROSS WEIGHT**" instead of "**GR**".
- Custom insertion of special parameters such as **time/date** and **identification no.**
- Truck mode custom printing.
- Custom continuous serial protocol.
- Custom '**P**' print out in duplex mode.

### FEATURES:

- \* Eight (8) custom print files automatically assigned.
- \* Eight (8) macro files for easy setup of headers, titles, etc. .
- \* Capability to upload and download the custom print files to a host computer.
- \* Maximum file length is 30 characters and/or parameters. Maximum number of characters in an output string is (250).

**Note!** Custom print does **not** support RS485 protocol

### STANDARD SERIAL CONFIGURATION:

The SMART SERIAL I/O Option allows standard serial output ports to be modified and

imported into the serial output data stream.

**CUSTOM PROTOCOL FILE SELECTION:**

The selection of the associated custom print file is performed automatically by serial port and the data mode (GROSS, NET, TOTAL RECALL, or SPECIAL) that the instrument is currently in at the time of a print. In other words, if Ports 1 & 2 were selected for demand print (dE) and the instrument was in the "GROSS" mode at the time of a print request of the data, the serial output for Port 1 would use the contents of file 1 (7.1) and the contents of file 5 (7.5) for Port 2.

The selections under Option 7 may be divided into three main functional groups; the first 8 files (7.1 to 7.8), each of which can store up to 30 ASCII and/or parameter codes, are files pertaining to the actual customization of serial output data and are themselves further subdivided into Port 1 files (7.1 to 7.4) and Port 2 files (7.5 to 7.8), the second functional group pertains to the 8 MACRO files (7.9 to 7.16) that may be entered into the primary files (7.1 to 7.8) by their associated parameter codes 600 to 607 (7.9 = parameter code 600 etc.), each of these files can also store up to 30 ASCII and/or parameter codes.

		CUSTOMIZING			
	FILE	NORMAL MODE	TRUCK MODE	MACROS (8)	MACRO Parameter codes
PORT 1	7.1	Gross data	Truck Mode Output Port is selected under option 4, Port 1 selection mirrors Port 2 below.	7.9	600
	7.2	Net data		7.10	601
	7.3	Total data		7.11	602
	7.4	Special (for future use)		7.12	603
PORT 2	7.5	Gross data	Truck Entry	7.13	604
	7.6	Net data	Truck Out Empty	7.14	605
	7.7	Total data	Truck Out Full	7.15	606
	7.8	Special (for future use)	Truck Fixed Tare	7.16	607

**Notes:**

If Option 7 is enabled ("**on**") but a designated file is set to **off** then that print mode will print



its default format (eg. file 7.1 **off** - the GROSS data from Port 1 is sent out in its default format).

### MACRO FILES (7.9 TO 7.16):

There are eight (8) macro files that can be accessed in any of the prime Print Files 1 - 8 (7.1 to 7.8) using the "600" series codes. Each macro file holds up to 30 ASCII characters and/or parameter codes.

**example:** A header stating the company's name **Scrap inc.** is desired when Port 1 outputs GROSS mode weight data.

Printout = Scrap inc.  
30000 LB GR 05/13/2005 12:30am

PRINT FILE 1 (7.1 - Port 1 "GROSS" mode data)

LINE #	CODE	CODE definition
01	002	STX (start of text)
02	600	* macro file #1 (7.9)
03	200	gross wt. with "LB/KG GR"
04	032	SP (space)
05	601	*macro file #2 (7.10)
06	013	CR (carriage return)
07	010	LF (line feed)
08	999	END OF FILE

#### CODE 600 (MACRO FILE 7.9)

LINE #	CODE	CODE definition
01	083	S character
02	099	c character
03	114	r character
04	097	a character
05	112	p character
06	032	SP (space)
07	105	i character
08	110	n character
09	099	c character
10	046	. (period)
11	013	CR (carriage return)
12	010	LF (line feed)
13	999	END OF FILE

#### CODE 601 (MACRO FILE 7.10)

LINE #	CODE	Defininition
01	402	Date
02	032	SP
03	401	Time
04	999	END

### CREATING AND EDITING FILES: OPTION 7 CONFIGURATION

<b>7.0</b>	Off, On	Enables smart serial
<b>7.X</b>	Off, On	Enables each print buffer 7.1.....7.16
	Key	Description
<b>7.1</b>	SET	Access buffer 7.1 and exit when done
	0-9	Use numeric keys to enter code 0-999
	ENT	Enter code
	CLEAR	Clear the code
	START/STOP	Insert code
	TARE RECALL	Clear entire (current) buffer
	GROSS/NET	Steps to next buffer position
	TARE	Go to first buffer position
	ZERO	Go to last buffer position

**IMPORTANT!** All files **must** be terminated with code 999

**CUSTOM PRINT FILES REMOTE READ AND WRITE**

**SSC** (Smart Serial Codes) command is provided to read or write buffer data 7.1...7.16.

Example:

Read

SSC<CR>

```
SSC 1 2 600 200 32 601 13 10 999
SSC 9 83 99 114 97 112 32 105 110 99 46 13 10 999
SSC 10 402 32 401 999
```

Write

SSC<sp><X><yyy><yyy><cr>    Where X = buffer 1...16 (7.1...7.16), yyy = code

With a txt editor (such as Windows Notepad) and the serial loader program, buffers can be created and edited.

Text strings can also be entered directly surrounded by quotes:

SSC 9 "Scrap inc." 702 999

Note: the 702 command CR/LF (13 10).

## ASCII CONTROL CODE CHART 1

CONTROL	CONTROL	SYMBOLS	NUMBERS
---------	---------	---------	---------

CHAR	CODE	CHAR	CODE	CHAR	CODE	CHAR	CODE
<b>NUL</b>	000	<b>DLE</b>	016	<b>SP</b>	032	<b>0</b>	048
<b>SOH</b>	001	<b>DC1</b>	017	<b>!</b>	033	<b>1</b>	049
<b>STX</b>	002	<b>DC2</b>	018	<b>"</b>	034	<b>2</b>	050
<b>ETX</b>	003	<b>DC3</b>	019	<b>#</b>	035	<b>3</b>	051
<b>EOT</b>	004	<b>DC4</b>	020	<b>\$</b>	036	<b>4</b>	052
<b>ENQ</b>	005	<b>NAK</b>	021	<b>%</b>	037	<b>5</b>	053
<b>ACK</b>	006	<b>SYN</b>	022	<b>&amp;</b>	038	<b>6</b>	054
<b>BEL</b>	007	<b>ETB</b>	023	<b>'</b>	039	<b>7</b>	055
<b>BS</b>	008	<b>CAN</b>	024	<b>(</b>	040	<b>8</b>	056
<b>HT</b>	009	<b>EM</b>	025	<b>)</b>	041	<b>9</b>	057
<b>LF</b>	010	<b>SUB</b>	026	<b>*</b>	042	<b>:</b>	058
<b>VT</b>	011	<b>ESC</b>	027	<b>+</b>	043	<b>;</b>	059
<b>FF</b>	012	<b>FS</b>	028	<b>,</b>	044	<b>&lt;</b>	060
<b>CR</b>	013	<b>GS</b>	029	<b>-</b>	045	<b>=</b>	061
<b>SO</b>	014	<b>RS</b>	030	<b>.</b>	046	<b>&gt;</b>	062
<b>SI</b>	015	<b>US</b>	031	<b>/</b>	047	<b>?</b>	063

## ASCII CONTROL CODE CHART 2

--	--	--	--

UPPER CASE		UPPER CASE		LOWER CASE		LOWER CASE	
CHAR	CODE	CHAR	CODE	CHAR	CODE	CHAR	CODE
@	064	P	080	`	096	p	112
A	065	Q	081	a	097	q	113
B	066	R	082	b	098	r	114
C	067	S	083	c	099	s	115
D	068	T	084	d	100	t	116
E	069	U	085	e	101	u	117
F	070	V	086	f	102	v	118
G	071	W	087	g	103	w	119
H	072	X	088	h	104	x	120
I	073	Y	089	i	105	y	121
J	074	Z	090	j	106	z	122
K	075	[	091	k	107	{	123
L	076	\	092	l	108		124
M	077	]	093	m	109	}	125
N	078	^	094	n	110	~	126
O	079	_	095	o	111		

**PARAMETER CONTROL CODE CHART**

--	--	--	--

CODE	DESCRIPTION	CODE	DESCRIPTION
200	GROSS WT & 'LB/KG GR'	240	TRUCK GROSS 'LB/KG GR'
201	GROSS WT & 'LG/KG'	241	TRUCK GROSS ONLY
202	GROSS WT	242	TRUCK TARE 'LB/KG TR'
203	GROSS WT(no 0 blanking)	243	TRUCK TARE ONLY
		244	TRUCK NET 'LB/KG NT'
210	NET WT & 'LB/KG NT'	245	TRUCK NET ONLY
211	NET WT & 'LN/KN'		
212	NET WT	300	STATUS CHARACTER
213	NET WT (no 0 blanking)	400	TIME & DATE PER SETUP
		401	TIME PER SETUP
220	TARE WT & 'LB/KG TR'	402	DATE PER SETUP
221	TARE WT & 'LT/KT'	500	IDENT NO. & 'ID. NO.'
222	TARE WT	501	IDENT NO. ONLY
223	TARE WT(no 0 blanking)		
230	TOTAL WT & lb/kg		
231	TOTAL WT & LA/KA	510	TICKET NO & COUNT
232	TOTAL WT ONLY	511	COUNT ONLY
233	TATAL WT (no "0" blanking)	702	CR/LF

## CUSTOM SERIAL ENTRY WORKSHEET

LINE	COD E	DESCRIPTION	LINE	COD E	DESCRIPTION
1			16		
2			17		
3			18		
4			19		
5			20		
6			21		
7			22		
8			23		
9			24		
10			25		
11			26		
12			27		
13			28		
14			29		
15			30		

**Option 8: AC/DC operation**

<b>8.1</b>	Off, On	Enables battery charger
<b>8.2</b>	Off, 5, 15, 30, 90, 120	Auto shutoff in minutes, timer resets with motion

**DISPLAY MESSAGES**

<b>MESSAGE</b>	<b>DESCRIPTION</b>
<b>DAC</b>	D/A card detected - Displayed under the check function.
<b>IIC.ERR</b>	IIC short - Power-up hardware failure indication.
<b>RST</b>	EEPROM is reset by EER command - Power-up message
<b>ON</b>	Displayed on power-up when the DC power push-button is pressed.
<b>AUTO</b>	EEPROM is reset - Power-up message
<b>ERR6.x</b>	Key-pad key is stuck.
<b>-232-</b>	Serial calibration/setup is active.
<b>UPDATE</b>	Enhancement calculation in progress.
<b>LO.BATT</b>	Low battery
<b>D BATT</b>	Dead battery
<b>ULULUL</b>	Under-load (-400 graduations under dead-zero)
<b>OLOLOL</b>	Over-load (+9 graduations or 105% from dead-zero reference)
<b>-----</b>	A/D acquisition is in progress.
<b>7x00</b>	Instrument mode selection.
<b>Err 10</b>	Number > 999999
<b>Err 13</b>	Number < -99999
<b>ADC.Err</b>	A/D hardware failure (channel one only).
<b>CHECK</b>	Check mode accessed.
<b>rC.xxxx</b>	Lower four-digits of the ROM check-sum.
<b>Err.80</b>	Serial command data error.
<b>Err.81</b>	Unknown serial command.
<b>-CAL-</b>	Remote calibration
<b>Err.OFF</b>	Hardware failure of the D.C. power on/off circuitry.
<b>RTC.RST</b>	The clock is reset to 01:01:04 12:00:00am.
<b>RST ID</b>	The ID EEPROM has been reset since it was detected as corrupt.
<b>AC OK</b>	Access code entered has been accepted.
<b>E-1234</b>	EEPROM set 1,2,3, and/or 4 have been fixed.
<b>Err 40</b>	Positive or negative signal overload (check sense connections).
<b>Err 31</b>	Bad tare entry
<b>Err 30</b>	Push to Zero out of range
<b>PC Err</b>	Piece Weight Entry is out of range



**115 to 220 VAC Conversion : EW1000 Bottom Side**

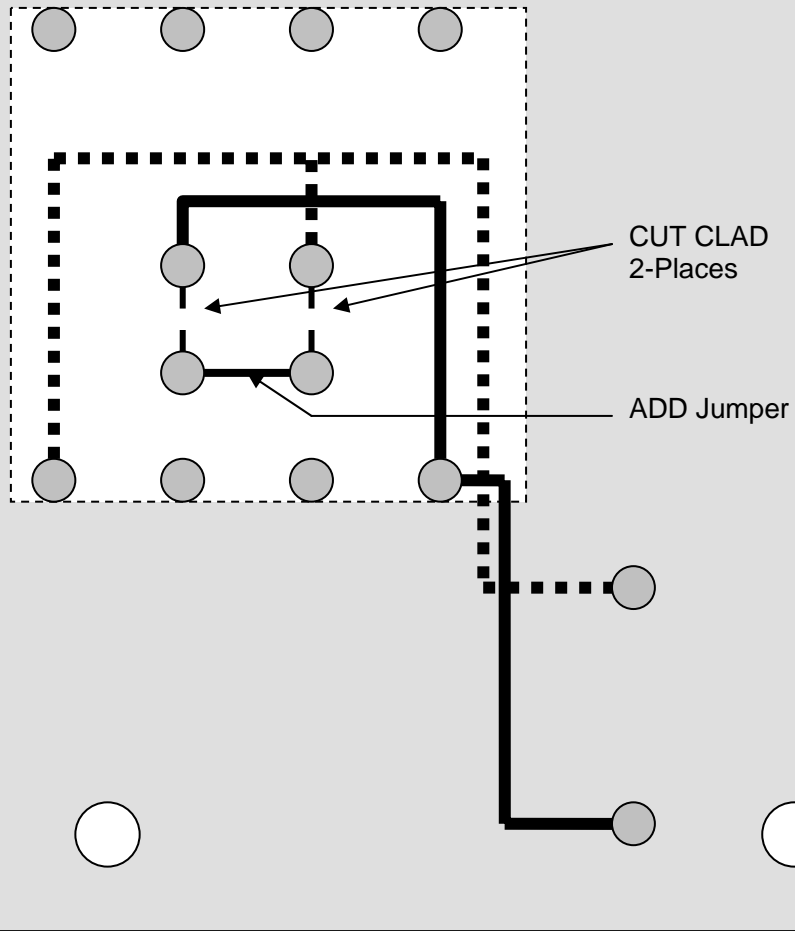

Spare Parts	
Part No.	Description
57819	Main Board
57512	Display Board
57860	Keypad Overlay
57675	Display Cable
56734	Load Cell T-Strip Conn.
	U-Bkt
56734	U-Bkt Knobs
	Enclosure
57811	Analog Output
TBD	Setpoint AC input
TBD	Setpoint DC input
	Second Channel