

AD-4322A Mark II (MK II)

Weighing Indicator

Instruction Manual

v.1.a 92.6.22

AND
A&D WEIGHING
...Clearly a Better Value

1555 McCandless Drive, Milpitas, CA 95035
Tel: (800) 726-3364 / (408) 263-5333 * Fax: (408) 263-0119
Fax-on-Demand: (800) 726-7099, Press 2 * Website: www.andweighing.com
Email: scales@andweighing.com



Contents

FCC Rules	Page	v
<i>Introduction</i>		
Welcome!.....	Page	2
Features.....	Page	3
Front Panel Description	Page	4
Rear Panel Description.....	Page	10
Specifications	Page	11
<i>Installation</i>		
General Rules.....	Page	17
Load Cell Connection	Page	18
Load Cell and Input Sensitivity.....	Page	18
Quick Installation.....	Page	19
<i>Basic Operation</i>		
'lb' or 'kg' Weighing.....	Page	25
Simple Weighing.....	Page	25
Simple Weighing with TARE.....	Page	26
TARE Clear.....	Page	27
Digital TARE.....	Page	28
<i>The Main Memory TOTAL Function</i>		
M+, M- and TOTAL keys.....	Page	30
Viewing All of the Code Set Values.....	Page	31
To Clear Code Set Values.....	Page	34
Adding/Subtracting to the Main Memory Total.....	Page	36
Main Memory Total Overflow.....	Page	36
Viewing the Main Memory Total	Page	37
To Clear the Main Memory Total	Page	38
To Set Auto Main Memory Total Add Mode.....	Page	39
<i>The Comparator Function</i>		
The Comparator Function.....	Page	41
To Store Comparator Setpoints.....	Page	42
Turning the Comparator On or Off.....	Page	45
<i>The ID/TARE Function</i>		
The I.D./Tare Function.....	Page	47
To Store ID/Tare	Page	47
Weighing Using Stored ID/Tare (RECALLing an ID/Tare).....	Page	49
To Exit from an ID/Tare.....	Page	49
Viewing All of the Stored ID/Tare's	Page	50
Clearing a Stored ID/Tare.....	Page	52
To Clear All of the Stored ID/Tare's	Page	52

The Code Function

Code Function Introduction.....	Page	54
Code Setting Flowchart	Page	55
To Enter Code Set Values.....	Page	56
Editing a Code Set.....	Page	60
Viewing All of the Code Set Values.....	Page	61
To Clear Code Set Values.....	Page	64
Using The Code Function.....	Page	66
Cancel of Code Setting.....	Page	67
Using the Code Total Memory.....	Page	69
Adding/Subtracting to the Code Total	Page	69
Code Total Overflow	Page	69
Viewing a Code Total	Page	71
Viewing All of the Code Total's.....	Page	72
To Clear a Code Total	Page	74
To Clear All of the Code Total's.....	Page	76

Printout

Simple Printing	Page	78
Simple Printing Examples	Page	78
Printing Main Memory Total	Page	80
To Print a Code Total.....	Page	81
To Print all of the Code Total's.....	Page	82
Auto Print	Page	83
To Select Auto Print Mode.....	Page	83
The M+ Print Mode.....	Page	85
To Select M+ Print Mode.....	Page	85
Using the M+ Print Mode.....	Page	87
Using the M+ Print Mode with Code	Page	88
Auto M+ Print Mode	Page	89
To Select Auto M+ Print Mode	Page	89
Using the Auto M+ Print Mode	Page	92
Using the Auto M+ Print Mode with Code	Page	93
Printing Items from the Memory.....	Page	94
I.D./Tare Settings Printout.....	Page	94
Code Settings Printout	Page	95
Printing the Time (with Option OP-09).....	Page	96
F-Function Settings Printout.....	Page	96
Printout Examples	Page	97

Truck Scale Mode

Track Scale Mode.....	Page	99
Track Scale	Page	100
To Clear Zero and Tare.....	Page	103
To Clear all of the Stored ID/TARE'S.....	Page	103
To Clear all of the CODE TOTAL'S.....	Page	104

Backup Data Initialization	Page	104
ID/TARE Data Initialization.....	Page	105
Clearing all CodeMemory Set	Page	105
Clearing all Backup Data, ID/TARE Data and Code Memory.....	Page	106
Calibration Data Initialization.....	Page	106
F-Function Data Initialization.....	Page	107
Calibration Data and F-Function Data Initialization.....	Page	107
All Data Clear and Initalization	Page	108
 <i>Calibration</i>		
About Calibration Terms.....	Page	110
If You Want To Perform:.....	Page	111
Calibration Flowchart	Page	112
Gravity Compensation Flowchart	Page	113
Digital Linearlization Flowchart	Page	114
Full Calibration Procedure	Page	115
Calibration Procedual Notes.....	Page	118
Calibration Errors	Page	119
Digital Linearlization.....	Page	120
Digital Linearlization Errors.....	Page	123
Gravity Compensation Function.....	Page	124
Using the Gravity Compensation Function.....	Page	126
Gravity Compensation Function Errors	Page	128
Gravity Values at Various Locations.....	Page	129
Acceleration due to Gravity.....	Page	129
World Latitude Map.....	Page	130
 <i>F-Functions</i>		
The F-Functions.....	Page	132
F-Function Setting Flowchart.....	Page	133
Changing the F-Functions	Page	134
F-Function Errors.....	Page	135
F-Functions And Their Settings.....	Page	136
 <i>I/O Interfaces & Operations</i>		
Standard Serial Output.....	Page	147
Parallel BCD Output Option OP-01.....	Page	149
External I/O Interface Option OP-02.....	Page	151
RS-232C Interface Option OP-04.....	Page	152
Analog Output Option OP-07	Page	170
Built-In Printer option OP-08	Page	172
Changing the Printer Paper.....	Page	173
The Digital Clock Option OP-09	Page	174
To Set the Clock	Page	174
Connection To An External Printer	Page	177
Panel Mounting Kit Option OP-10.....	Page	181

Wall Mounting Kit Option OP-11.....	Page	182
Dimensions	Page	183



Compliance with FCC Rules

Please note that this equipment generates, uses and can radiate radio frequency energy. This equipment has been tested and has been found to comply with the limits of a Class A computing device pursuant to Subpart J of Part 15 of FCC rules. These rules are designed to provide reasonable protection against interference when equipment is operated in a commercial environment. If this unit is operated in a residential area it might cause some interference and under these circumstances the user would be required to take, at his own expense, whatever measures are necessary to eliminate the interference.

(FCC = Federal Communications Commission in the U.S.A.)

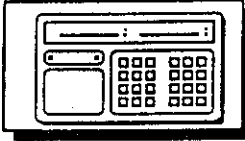

AD-4322AMKII Weighing Indicator

Introduction



Welcome!

Thank You for Your **AND** Purchase!

This is an INSTRUCTION MANUAL for the AD-4322AMarkII Weighing Indicator. The AD-4322AMarkII is the product of years of design, development, and in-field testing. It is designed to withstand harsh environmental conditions – and each indicator is subjected to several levels of quality control before it leaves the factory. Every care has been taken during the manufacturing process of this indicator to ensure that it will perform accurately and reliably for many years.

During a weighing event, the AD-4322AMarkII Indicator detects stress generated by Load Cells - producing an analog output signal. This signal is amplified and used as the input signal for an analog to digital converter. The final digital signal is used to calculate the weight for the display. The AD-4322AMarkII is screened against Radio Frequency Interference (RFI), employs Full Digital Calibration (FDC) and contains WATCHDOG circuitry which constantly monitors the central processing unit and which will instantly reset the CPU if a software crash starts to develop.



Features

- M+, M- function.
- ID/Tare function.
- Code function.
- Comparator function.
- Standard Serial Output.
- Optional built-in printer.
- Optional Time/Date function.
- Waterproof (without optional printer).
- Four levels of digital filter.
- Digital Linearization function.
- Gravity Compensation function.
- Can be used on a desktop, wall or panel mounted.
- Simple calibration via FDC (Full Digital Calibration) function.
- Watchdog circuitry virtually eliminates malfunctions commonly associated with computerized equipment.
- Screened against RFI (Radio Frequency Interference).
- Convenient optional interfaces: parallel BCD (Binary-Coded-Decimal); External I/O, Analog Output; and Serial RS-232C/Current Loop (Passive).
- High A/D resolution and accuracy.
- Eight digits I.D. number and CORD number can be entered.
- Weighing data including I.D. number and CORD number can be printed using the built-in printer (OP-08) or an external printer.
- Setting, changing, readout and clearing the ID/TARE data and code data are possible through the RS-232C interface (OP-04).



Front Panel Description

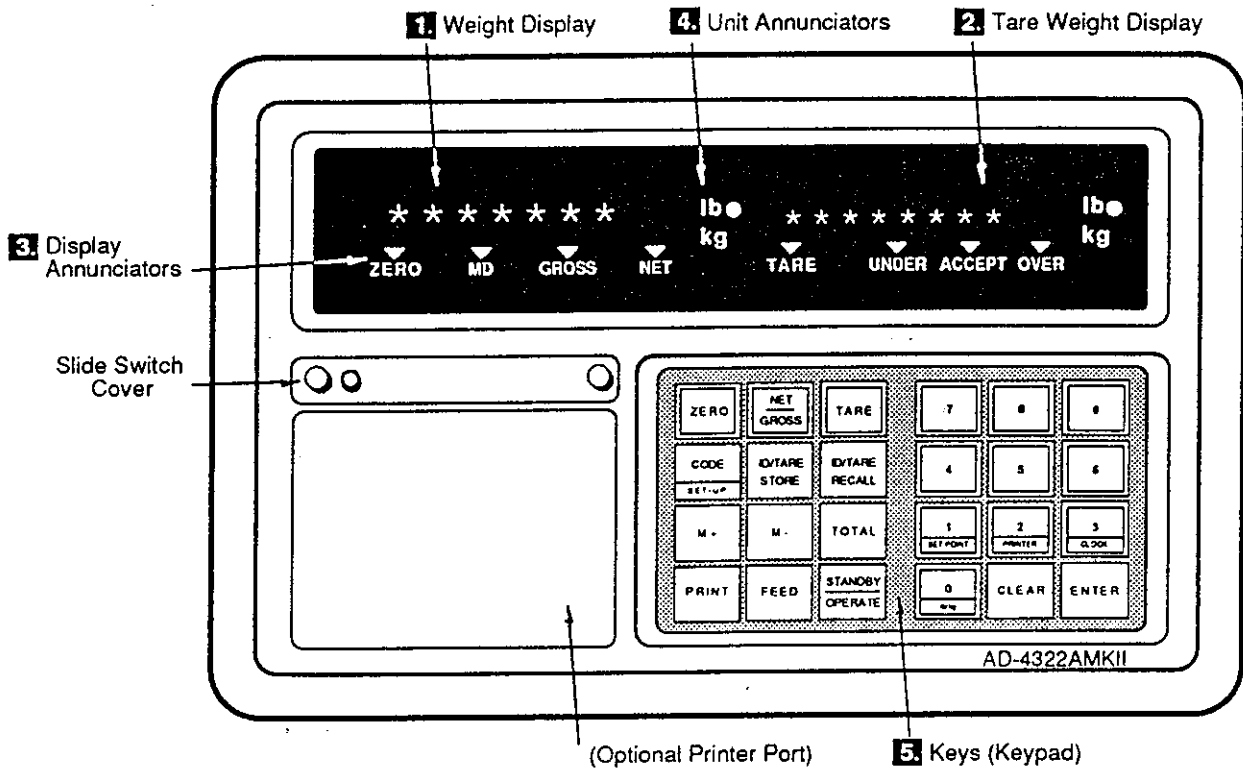

1. Weight Data Display

A seven digit display that shows the weight acting on the weighing device.



2. Tare Weight Display

An eight digit display that shows the TARE weight being used (if any).



3. Display Annunciators

▼
ZERO

The **ZERO** Annunciator triangle will appear when the display is showing the center of ZERO.

▼
MD

The **MD** (Motion Detection) Annunciator triangle will appear when the display is unstable due to weighing device motion.

▼
GROSS

The **GROSS** Annunciator triangle will appear when the display is in the GROSS mode, the display showing the GROSS weight.

▼
NET

The **NET** Annunciator triangle will appear when the display is in the NET mode, the display showing the NET weight.

▼
TARE

The **TARE** Annunciator triangle will appear when a TARE weight has been entered.

▼
UNDER

The **UNDER** Annunciator triangle will appear when the weight value is under the set Lower Limit.

▼
ACCEPT

The **ACCEPT** Annunciator triangle will appear when the weight is over the set Lower Limit, and under the set Upper Limit.

▼
OVER

The **OVER** Annunciator triangle will appear when the weight value is over the set Upper Limit.

4. Unit Annunciators

lb 
USA version only

The **lb** Annunciator light will appear when the AD-4322AMKII is in the pound weighing mode - the displayed weight is in pounds. *note: lb/kg version only (USA).*

kg 

The **kg** Annunciator light will appear when the AD-4322AMKII is in the kilogram weighing mode - the displayed weight is in kilograms.

t 
International version only

The **t** Annunciator light will appear when the AD-4322AMKII is in the tonne weighing mode - the displayed weight is in tonne. *note: International version only.*

5. Keys



The ZERO Key

The **ZERO** key returns the display to the center of ZERO when the weighing device is empty (user selected within $\pm 2\%$ or 10% of the maximum capacity), and motion is not detected (**▼MD** annunciator is not ON). It should not be confused with the **TARE** key which re-ZERO's the display and switches to NET mode.

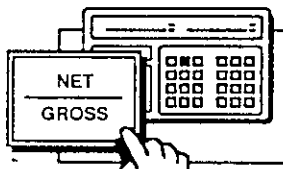

The NET/GROSS Key

The **NET/GROSS** key switches between the two modes. The **▼** annunciators and display will alternate between NET and GROSS.

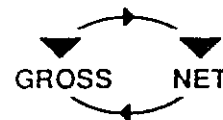

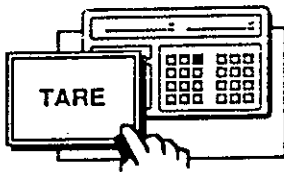

The TARE Key

The **TARE** key switches to NET mode; ZERO's the weight display, shows the TARE weight on the TARE display (if motion is not detected), and the ▼TARE Annunciator will come ON. TARE weight that is greater than one division, to full capacity, can be entered (see p. 26).

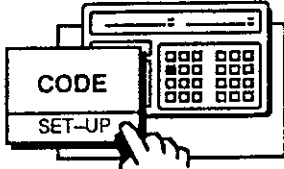

The CODE (SET-UP) Key

The **CODE** key is most often used to activate the code number input mode. It is also used in conjunction with other keys to find code totals, etc.

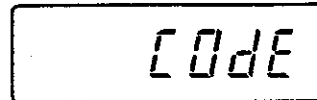

When the **CODE SET-UP** key is held down for 5 seconds, the display will go to the SET-UP mode for the Comparator, Printer, Digital Clock, etc.

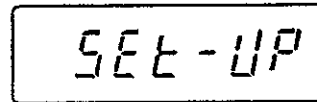

The ID/TARE STORE Key

The **ID/TARE STORE** key activates the TARE weight store mode. A TARE weight with corresponding I.D. number is stored (see p. 47).



The ID/TARE RECALL Key

The **ID/TARE RECALL** key activates the TARE recall mode. A TARE is recalled after entering its I.D. number (see p. 49).

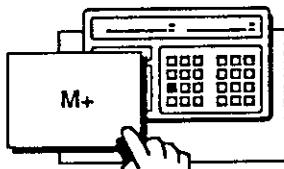

The M+ Key

If the **M+** key is pressed, the displayed weight will be added to the main memory TOTAL and 1 will be added to the 'In' count (inputs, the number of times the **M+** key was pressed to add to the main memory TOTAL), (see p. 36). It will also be added to the CODE TOTAL if a code set is active, (see p. 69).

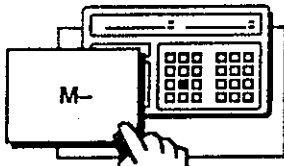

The M- Key

When you press the **M-** key, the displayed weight will be subtracted from the main memory TOTAL and 1 will be subtracted from the count of 'In' (inputs, the number of times the **M-** key was pressed to subtract from the main memory TOTAL), (see p.36). It will also be subtracted from the CODE TOTAL if a code set is active, (see p. 69).

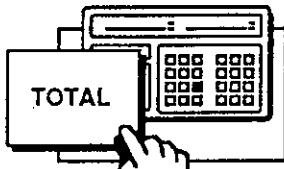

The TOTAL Key

When the **TOTAL** key is pressed, the stored main memory total will be displayed (see p. 37,71, 80-82).

total

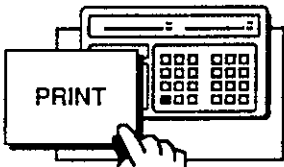

The PRINT Key

- When the **PRINT** key is pressed, the displayed weight will be printed by the optional (OP-08) built-in printer. If a code number is active, it is also printed (see p. 172).
- If you are displaying main memory TOTAL (or CODE TOTAL) weight, then the total will be printed when the **PRINT** key is pressed (see p. 80→82).
- Depending on how output F-Function's are set, the **PRINT** key also transmits to a printer via Option OP-01 (BCD output), or Option OP-04 (RS-232C interface) and Standard (Current Loop).

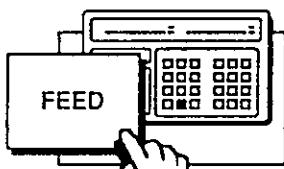

The FEED Key

The **FEED** key feeds the optional built-in printer's paper.

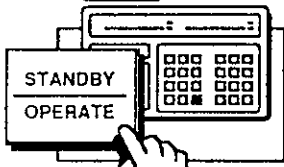

The STANDBY/OPERATE Key

The **STANDBY/OPERATE** key switches between the STANDBY mode and the OPERATE mode. In the STANDBY mode, the display and data outputs are Off, but not the power supply. The power cord must be removed to disconnect power to the AD-4322AMKII.

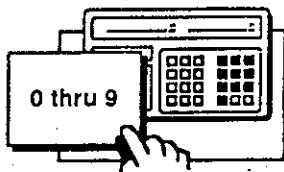

The 10-KEY Keys

The numerical keys are used when inputting digital data such as known TARE weights, I.D. numbers, comparator limits, etc.

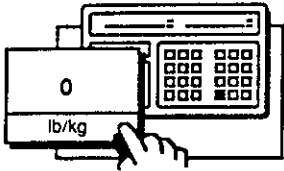

The 0/Lb/Kg Key *USA Version ONLY*

The lb^0/kg key (w/ENTER, see p. 25) switches the display between pound and kilogram weighing. The weighing unit annunciators will alternate between 'lb' and 'kg' (this can also be done via F-Function F-2)

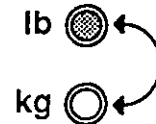

⚠ If you want to convert a displayed lb weight to kg, calibration must be done in the lb mode. (see p. 25)

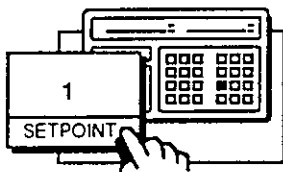

The 1/SETPOINT Key

The SETPOINT^1 key is used to turn the comparator On or Off (see p. 45), and to set the comparator limits (see p. 42).

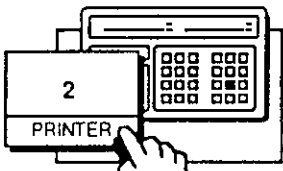
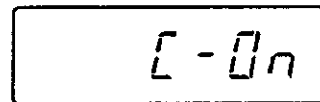

The 2/PRINTER Key

The PRINTER^2 key is used to turn option OP-08 auto printer functions On or Off (see p. 83).

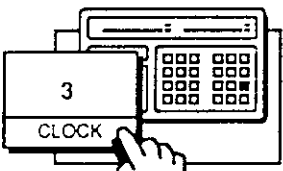
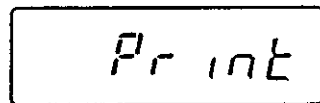

The 3/CLOCK Key

The clock^3 key is used in setting the optional OP-09 clock (see p. 174).

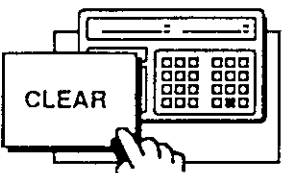

The CLEAR Key

The CLEAR key clears the TARE weight, or clears the display if a number has been incorrectly entered (see p. 27).



The ENTER Key

The **ENTER** key will enter a number from the display (via the 10-keys) and then move to the next step. **¶**



Rear Panel Description

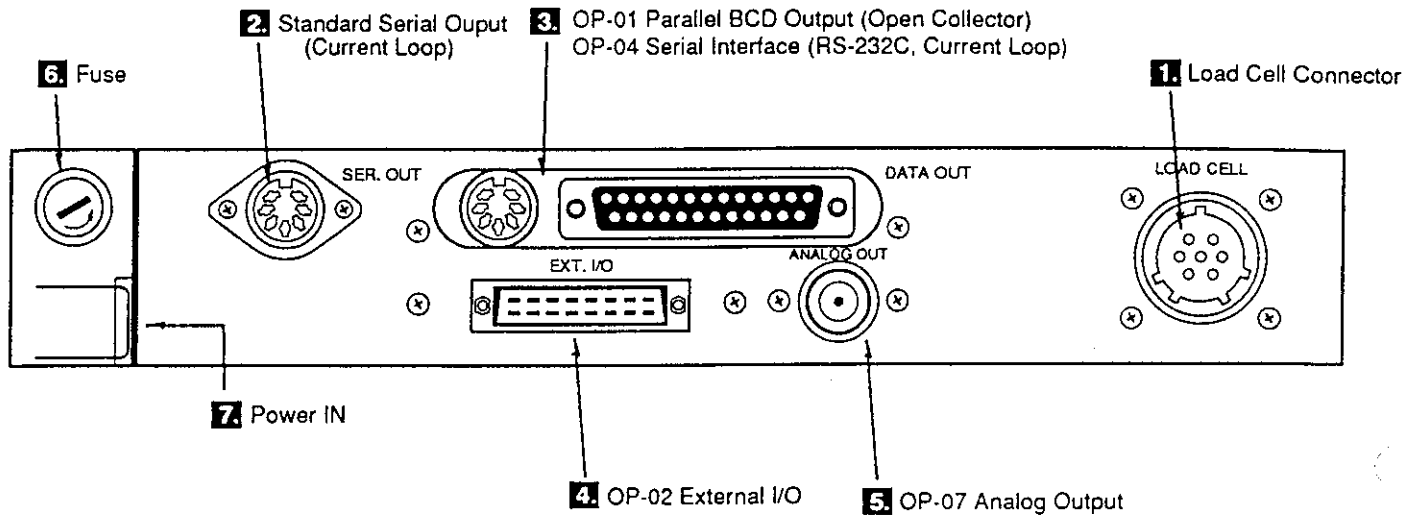

1.

Load Cell Connector (see page 18).



2.

Standard Serial Output (Current Loop) connector for external printer or display (see page 147).



3.

Option (only one may be installed):

OP-01 Parallel BCD Output (open collector) connector (see p. 149).

OP-04 Serial Interface (RS-232C, Current Loop) connector (see p. 152).



4.

Option OP-02 External I/O (6 inputs, 3 outputs) connector (see p. 151).



5.

OP-07 Analog Output (4 → 20mA) connector (see page 170).



6.

Fuse: 0.5A 100 → 120V (slow blow)
0.3A 200 → 240V (slow blow)



7.

Power IN.



Specifications

■ ANALOG INPUT and A/D CONVERSION

Input Sensitivity	0.6 μ V/D (D="min. division" or "graduation")
ZERO Adjustment Range	-6mV \rightarrow 30mV
Load Cell Excitation	12V DC \pm 5% 280mA max. (up to 8, 350 Ω load cells)
ZERO Temperature Comp.	\pm (0.2 μ V + 0.0008% of Dead Load)/ $^{\circ}$ C TYP
Span Temperature Comp.	\pm 0.0008% / $^{\circ}$ C TYP
Non-Linearity	0.01% F.S.
Input Noise	\pm 0.3 μ V _{p-p}
Input Impedance	10 M Ω (minimum)
A/D Conversion Method	3 phase, true integrating dual-slope type
A/D Resolution	330,000 Counts Max.
A/D Conversion Rate	approx. 16 times/second (63 m sec/conversion)

■ DIGITAL SECTION

Weighing Display	High intensity 7-segment, 13 mm(h) blue fluorescent
Tare Display	High intensity 8-segment, 11 mm(h) blue fluorescent
Display Resolution	20,000 counts (maximum)
Minimum Division	times 1, x2, x5, x10, x20, x50
Maximum Display	"+999950"
Under ZERO Indication	"-" minus sign
"ZERO" ∇ Annunciator	Center of ZERO (0 \pm 0.25D)
"MD" ∇ Annunciator	Motion Detection
"GROSS" ∇ Annunciator	GROSS Mode
"NET" ∇ Annunciator	NET Mode
"TARE" ∇ Annunciator	Tare is currently displayed
"UNDER" ∇ Annunciator	Weight value is under set Lower Limit
"ACCEPT" ∇ Annunciator	Weight is over set Lower Limit, under set Upper Limit
"OVER" ∇ Annunciator	Weight value is over set Upper Limit
"lb" \bullet Annunciator	Pounds Displayed (lb or kg version)
"kg" \bullet Annunciator	Kilograms Displayed
"t" \bullet Annunciator	Tonne Displayed (kg or t version)
STANDBY / OPERATE KEY	Activates display and functions.
ZERO Key	ZERO's the Display when stable.
TARE Key	Tare when stable - in NET mode, display ZERO.

GROSS / NET Key	Changes from "GROSS" to "NET" and vice versa.
PRINT Key	Prints, or initiates printing via current loop OP-01 or OP-04.
CODE Key	"STORE" mode: stores CODE information into memory. "RECALL" mode: Recalls stored CODE information from memory.
ID / TARE Key	"STORE" mode: Stores TARE weight into memory. "RECALL" mode: Recalls stored TARE weight from memory.
CLEAR Key	CLEAR's the stored TARE or CODE info.
ENTER Key	ENTERS the Display/moves to next level.
M+ Key	Adds displayed weight into memory.
M- Key	Subtracts displayed weight from memory.
TOTAL Key	Displays the TOTAL weight in memory.
FEED Key	Paper feed (optional built-in printer, OP-08).

GENERAL

Power Requirements	100,117,220,240V AC +10%,-15% 50/60Hz
NET Weight	Approx. 3.5kg (7.8lb)
Operating Temperature	-5°C to 40°C (23°F to 104°F)
Maximum Humidity	85% (non-condensing)
Physical Dimensions	310mm (W) x 149mm (D) x 192mm (H) 12.2" x 5.9" x 7.6"
Memory Battery Back-up	Lithium, 6 years or more without AC power.

ACCESSORIES

Instruction Manual
Fuse: 0.5A Time Lag (100 → 120V) slow blow or 0.3A Time Lag (200 → 240V) slow blow.
Load Cell Connector
Standard Serial Output Connector
Power Cable
Capacity Sticker

OPTIONS

Option OP-01	Parallel BCD (Binary-Coded-Decimal) output (DATA OUT). Output data: weight, NET/GROSS, MD Decimal point, lb, kg, (t), print trigger, overload.
Option OP-02	External I/O. Output of Comparator signals. Input of ZERO, TARE, TARE CLEAR, NET/GROSS, PRINT, STANDBY/OPERATE.
Option OP-04	Serial Interface. Two types of serial interface are available with this option: 1) EIA-RS-232C. 2) 20mA current loop (passive). Baud Rate & Format are identical to RS-232C.
Option OP-07	Analog output (4-20mA).
Option OP-08	Built-in printer with feed. 24 digits/line.
Option OP-10	Panel Mounting Kit.
Option OP-11	Wall Mounting Kit.

WEIGHT CONVERSION TABLE

One kg = 2.204 62 lb(avoir) approximately.
One lb = 0.453 59kg.
One t = tonne 1,000kg (Metric Ton) or 2,204.62 lb approximately.
= ton, long: (20 cwt) 2,240 lb or 1,016.05kg approximately.
= ton, short: 2,000 lb or 907.18kg approximately.
= ton 216 imp. gal. (ale), 252 imp. gal. (wine). "weight"=volume x density. One imp. gal. of distilled water at 62°F=10 lb=4.536kg but also equals about 4.546 liters/dm ³ /kg at 4°C. One liter of water at 4°C equals 1kg. One US gal. is about 5/6 of an imp. gal. or about 3.785 liters.

■ F-FUNCTIONS and SETTINGS

□ General (pages 136-138)

F 01	Decimal Point Adjustment	Displays to 1,2,3 or 4 decimal places.
F 02	Weighing Unit Selection	"lb"↔"kg" (USA version only) "kg"↔"t" (International version only)
F 03	Display Update Rate	Selectable:16 times/sec. → Display Hold
F 04	Digital Filter	Selectable: Week → Strong.
F 05	Set ZERO Range	2% or 10% of Maximum Capacity.
F 06	Motion Detection Condition	Selectable: 0.5 sec, 1 cnt → 1 sec, 9 cnt
F 07	Auto. ZERO Track. Comp.	Selectable:1 sec, 5 div. → 2 sec, 4.5 div.
F 08	Hertz Selection	50Hz↔60Hz

□ For Control I/O Interface Option OP-02 (page 139)

F 11	Key Inhibit	Front Key & EXT Input available, EXT Input only.
F 12	Comparator Mode	Always available, Stable, More than 5D, Stable & more than 5D.

□ For Standard Serial Out (page 139-140)

F 21	Baud Rate	600, 2400 Baud.
F 22	Output Data	Display, GROSS, NET, Tare or Gross+Net+Tare Data.
F 23	Output Mode	Stream, Auto Print, PRINT key.
F 24	Output Availability	Always Available, or Stable Only

□ For Parallel BCD Output Option OP-01 (page 141)

F 31	Output Data	Display, GROSS, NET, or Tare Data.
F 32	Output Mode	Stream, Auto Print, PRINT Key.
F 33	Output Logic	Positive Logic, Negative Logic.
F 34	Output Format	Normal, Special.

□ For Serial Interface Option OP-04 (pages 141-142)

F 41	Baud Rate	600, 1200, 2400, 4800, 9600.
F 42	Output Data	Display, GROSS, NET, Tare or Gross+Net+Tare Data.
F 43	Output Mode	Stream, Auto Print, Print Key, Command.
F 44	Output Availability	Always Available, Only when Stable

□ For Analog Output Option OP-07 (page 143)

F 51	Analog Output Data	Display, Gross, or Net Data.
F 52	Analog Output at Zero	Selectable from 0.0mA to 99.9mA.
F 53	Analog Output at Full Scale	Selectable from 0.0mA to 99.9mA.

For Built-In Printer Option **OP-08** (pages 144-145)

F 61	Printer Output Format	Various Selectable.
F 62	Paper Feed after Printing	0, 1, 2, or 4 lines.
F 63	Auto Clear after Printing TOTAL	No, Main Total Only, Main & Code Total
F 64	Hour Mode	24 hour, or 12 hour.

Printouts with Digital Clock Option **OP-09** (page 145)

F 71	Date Format	DD/MM/YYYY or MM/DD/YYYY.
-------------	-------------	---------------------------

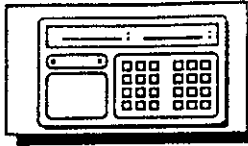

AD-4322AMKII Weighing Indicator

Installation



General Rules

- Don't install the AD-4322AMarkII in direct sunshine. Avoid sudden temperature changes, vibration, or wind (with the built-in printer, also avoid water or excessive dirt).
- Best temperature is about 20°C/68°F at about 50% Relative Humidity.
- Ground the AD-4322AMarkII via the power cable to the rear terminal. Ensure a good ground connection. Do not ground directly to other equipment.
- Analog input/output signals are sensitive to electrical noise. Do not bind these cables together as it could result in cross-talk interference. Please also keep them well away from AC power cables. Keep all cable/coax as short as possible.
- If the local AC electrical supply fluctuates by more than $\pm 10\%$ an AC regulator must be used to stabilize the power supply (This includes power spikes).



Load Cell Connection

- Use a six wire cable with shield. If the AD-4322AMKII is located near the Load Cells (within a few yards or meters) you may use a 4 wire cable with shield, but first connect pins 1 to 2 and 3 to 4 with independent jumper leads.



- The analogue output from the Load Cell and the RS-232C input/output signals are sensitive to electrical noise. Do not bind these cables together as it could result in cross-talk interference. Please also keep them well away from AC power cables.

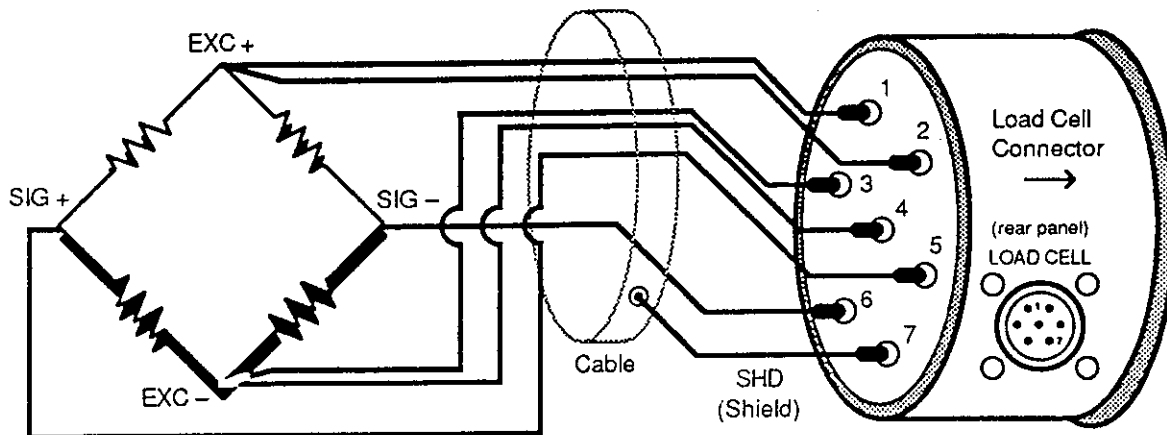

Load Cell Connections			
Pin	Signal	Pin	Signal
1	Positive Excitation Voltage (EXC+)	5	Positive Signal Voltage (SIG+)
2	Positive Sense Voltage (SEN+)	6	Negative Signal Voltage (SIG-)
3	Negative Sense Voltage (SEN-)	7	Shield (SHD)
4	Negative Excitation Voltage (EXC-)		



Load Cell and Input Sensitivity

The relationship between Load Cell and Input Sensitivity (X) for the AD-4322AMKII is as follows:

<input type="checkbox"/> Example	Load Cell Capacity	100kg	"A"
	Rated Output	3mV/V	"B"
	Min. Division of Display	0.01kg	"D"

- When a single Load Cell without a lever is used, the following formula should apply:

$$"X" = \frac{12000 \times B \times D}{A}$$

- System design will be satisfactory if "X" is greater than 0.6µV. In the example above "X" = 3.6µV.



Quick Installation



This section is for those users who wish to simply get the AD-4322AMKII up and working for simple use or testing; it is just intended for the initial installation. If you are going to be using the AD-4322AMKII in a more complicated system, or unusual environment, you may want to study the F-Function or Calibration sections before installation or testing. If you are unfamiliar with any of the terms below, you will find explanations in the Calibration Terms section, page 110, Calibration section.

■ **Unpack the AD-4322AMKII:**

Remove the AD-4322AMKII unit from its packaging - please check that all items on the packing list are included before discarding packaging.

■ **Connect to Load Cell(s):**

Connect the AD-4322AMKII to the Weighing Device Load Cell(s) via the back panel Load Cell connector. See the Load Cell Connection section on the previous page.

■ **Connect to Power:**

Connect the AD-4322AMKII to power. Verify that the unit is grounded correctly.



lb/kg display conversion requires calibration done in pounds! Otherwise, the displayed weight will not be converted (see page 25).

For USA Users

■ **Set Minimum Division:**

For reference, please see page 110

Step 1.

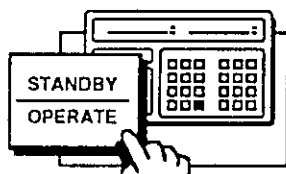

Press the **STANDBY OPERATE** key to turn the display On (if needed), and have nothing acting on the weighing device.

Step 2.

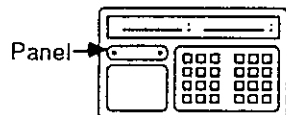

Open the panel cover on the front of the AD-4322AMKII unit by unscrewing the knobs - to expose the slide-switches.

Step 3.



Slide the middle CAL slide-switch ON⇒.

Display

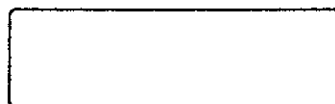
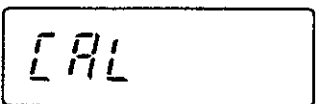

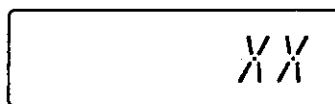

"CAL" will appear briefly followed by:

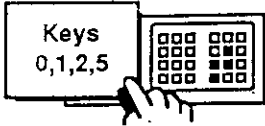

"xx" here is any previously entered minimum division.

- Step 4.
- A) If you do not want to change the Min. Division, go to Step 5.
 - B) If you wish to change the minimum divisions - please use the key pad now to display the new division. 
 - You are limited to one of the following Minimum Divisions: 1, 2, 5, 10, 20, or 50 (see MIN. DIV. explanation, p. 110 for more information).

- Step 5.
- A) If there is no change, or B) When the correct new setting is displayed, press the **ENTER** key. 

Display   "." will appear briefly, followed by:

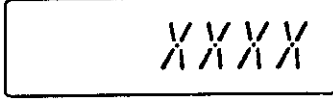

■ Set Maximum Capacity:

For reference, please see page 110.

  "XXXX" here is any previously entered maximum capacity.

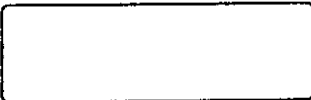

- Step 6.
- A) If you don't want to change the Max. Capacity, go to Step 7.
 - B) If you wish to change the maximum capacity - please use the key pad now to display the new Max. Capacity. 

- Step 7.
- A) If there is no change, or B) When the correct new setting is displayed, press the **ENTER** key. 

Display   "." will appear briefly, followed by:

■ Perform ZERO Calibration:

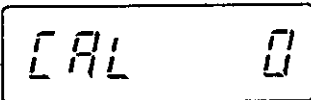
For reference, please see page 111.

  "CAL 0" for ZERO CALIBRATION will be displayed.

Note: If ZERO Calibration is not needed, press the **TARE** key and go to SPAN Calibration.



Step 8.  Wait until the "MD" (motion detection)  indicator disappears.

Step 9.  Press the **ENTER** key.

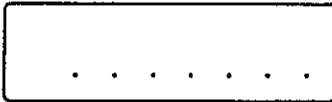
Display   "." will appear briefly, followed by:

Perform SPAN Calibration:

For reference, please see page 111.

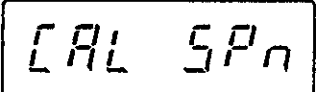
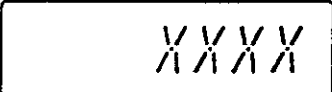
  "XXXX" here is any previously entered Maximum Capacity.



Note: If SPAN Calibration is not needed, press the **TARE** key and go to Step 13.



Step 10. If your calibration mass is the same as the Maximum Capacity, place the calibration mass on the weighing device - continue to Step 11.

If you are not using Max. Capacity as your SPAN weight, or the exact weight of the Cal. Mass is known - please enter in the weight of the calibration mass by using the key pad.

○ Place the calibration mass on the weighing device.

Step 11.  Wait until the "MD" (motion detection)  indicator disappears.

Step 12.  Press the **ENTER** key.

Display   "." will appear briefly, followed by:

 "CAL End" will be displayed.

Note: You may now remove the calibration mass from the weighing device.

Step 13.  Slide the middle CAL slide-switch OFF←, replace the panel cover. 

■ ***Setting the Decimal Place:***

To set the decimal place - please follow the example given in the CHANGING THE F-FUNCTIONS procedure (page 134) in the F-FUNCTION section (The example given is how to set the decimal place).

■ ***Problems:***

If you have any problems such as error messages, please see: CALIBRATION ERRORS (page 119); CALIBRATION TERMS (page 110); and THE FULL CALIBRATION PROCEDURE (page 115) in the CALIBRATION section. Other than that, please study the reference sections, and possibly THE F-FUNCTIONS AND THEIR SETTINGS section for specific problems.

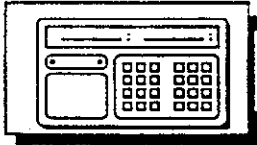

AD-4322AMKII Weighing Indicator

Basic Operation



'lb' or 'kg' Weighing

For
USA Users



The display can be alternated between pound and kilogram weighing using the following operation.

Step 1.

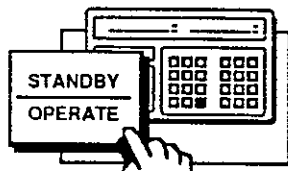

Press the **STANDBY OPERATE** key to turn the display On (if needed).

Step 2.

Press and hold the **ENTER** key, then press the number **0** key - release the keys.

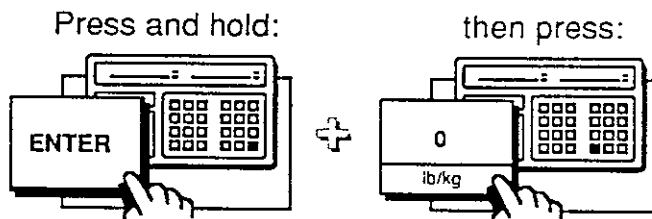

Display

The annunciators will alternate between 'lb' and 'kg'.

The unit is convertible if calibration is made in pounds.

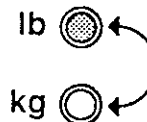

Simple Weighing

Step 1.

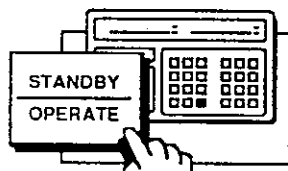

Press the **STANDBY OPERATE** key to turn the display On (if needed) and Zero the display (if needed).

Step 2.

Place the object(s) to be weighed on the weighing device (example: a 50kg component).

Display

After the Motion Detection (**▼MD**) annunciator goes Off, the weight will be displayed on the left display panel.

Example:

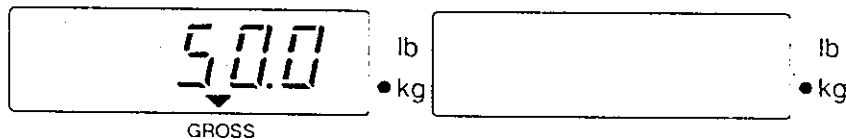



Simple Weighing with TARE

Step 1.

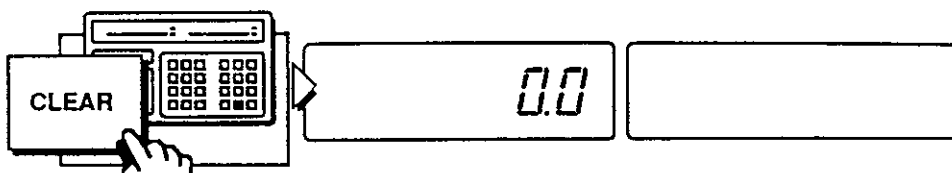

- ▶ Press the **CLEAR** key to clear the TARE display (if needed).

Step 2.

Place the empty tare container on the weighing device (example: a 10kg container).

Step 3.

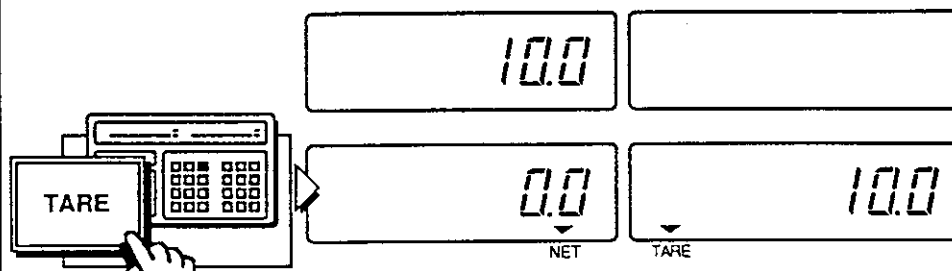

Display Examples

- ▶ After the Motion Detection (**▼MD**) annunciator goes Off - Press the **TARE** key.
- The TARE weight will be displayed on the right display panel. The **▼TARE** annunciator will come On, and the display will switch to NET mode (**▼NET**).

Step 4.

Place the object(s) to be weighed into the tare container (example: a 5kg component).

Display

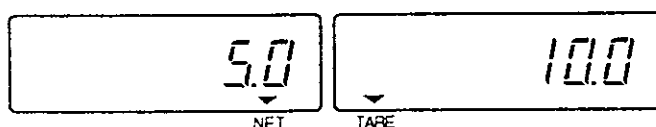

Display Example

- After the Motion Detection (**▼MD**) annunciator goes Off - the object weight will be displayed on the left display panel, the TARE weight will continue to be displayed on the right. **▼**



TARE Clear



While in the weighing mode, TARE can be cleared by pressing the **CLEAR** key. TARE can also be cleared by pressing the **TARE** key when the GROSS weight is "zero".

Either:

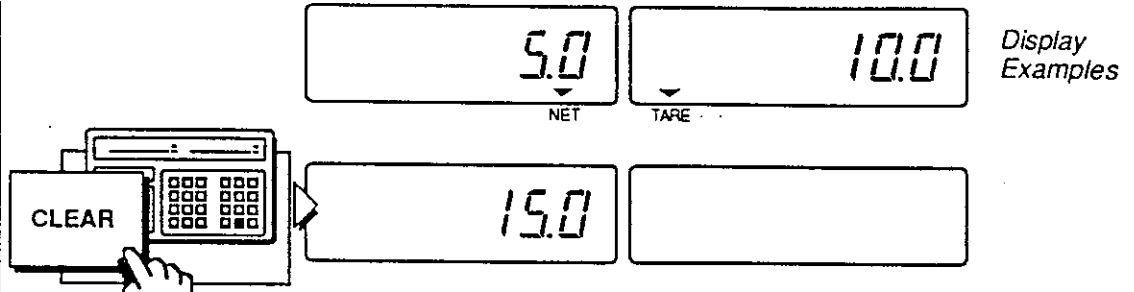

- While in the weighing mode, TARE can be cleared by pressing the **CLEAR** key.

Or:

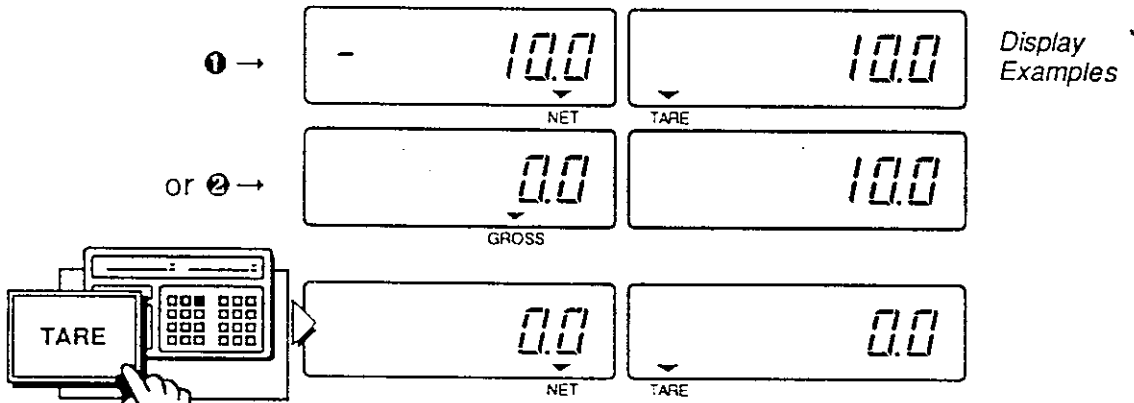

- TARE can also be cleared by pressing the **TARE** key when
 - the NET weight display is negative the TARE weight, or
 - the GROSS weight display is "zero".



Please note that when using the **TARE** key to clear TARE, it does not move you from NET to GROSS mode. You will have to press the **NET/GROSS** key.





Digital TARE



Instead of placing a tare container on the weighing device and pressing the **TARE** key, you can enter the weight of the tare container via the 10-key pad.

Step 1.

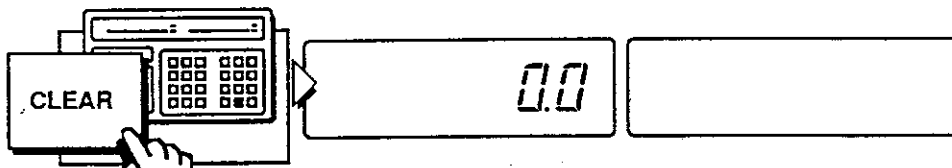

▶ Press the **CLEAR** key to clear the TARE display (if needed).

Step 2.

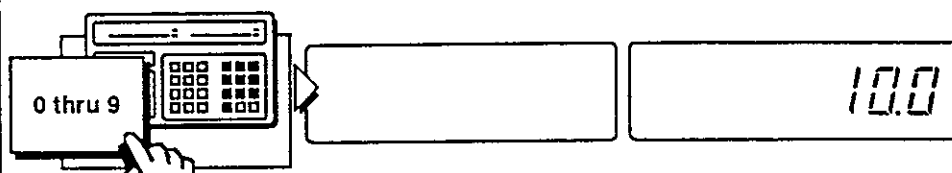

Display Example

▶ Use the 10-key pad to enter in the TARE weight, for example, 10kg.

Step 3.

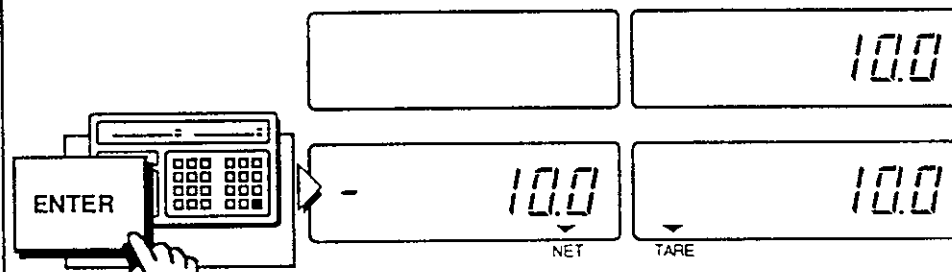

Display Example

- ▶ Press the **ENTER** key.
- The TARE weight will be displayed on the right display panel, and the TARE value will show as a negative number on the left display. The ▼TARE annunciator will come On and the display will switch to NET mode (▼NET).

Step 4.

Place the tare container with the object(s) to be weighed (example: the 10kg container and a 5kg component) on the weighing device.

Display

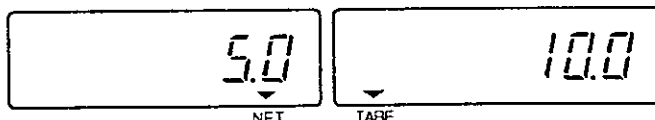

Display Examples

- After the Motion Detection (▼MD) annunciator goes Off - the object weight will be displayed on the left display panel, the TARE weight will continue to be displayed on the right. ▼

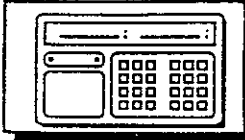

AD-4322AMKII Weighing Indicator

The Main Memory TOTAL Function



M+, M- and TOTAL Keys



The AD-4322AMKII has the ability to keep a running memory total and the number of times, 'In' (inputs), the memory has been added/subtracted to. The total is called the 'Main Memory TOTAL' to differentiate it from the CODE TOTAL that can also be used with the CODE function.

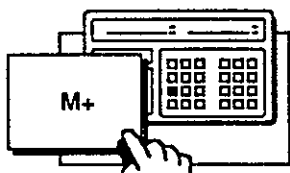

- When you press the **M+** key, the displayed weight will be added to the main memory TOTAL and 1 will be added to the 'In' count (inputs, the number of times the **M+** key was pressed to add to the main memory TOTAL). •If a code memory set is active, then the weight will also be added to its CODE TOTAL.

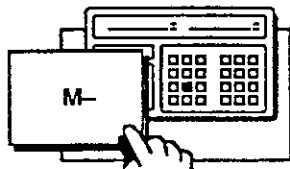

- When you press the **M-** key, the displayed weight will be subtracted from the main memory TOTAL and 1 will be subtracted from the count of 'In' (inputs, the number of times the **M-** key was pressed to subtract from the main memory TOTAL). •If a code memory set is active, then the weight will also be subtracted from its CODE TOTAL.

When the **M+** or **M-** key is pressed repeatedly, key operations can be selected for valid or invalid by pressing the F-16 key.

When repeated operation is selected, weighing data is added to or subtracted from the memory by each pressing the **M+** or **M-** key.

When non-repeated operation is selected, weighing data is added or subtracted one time, the AD-4322AMKII holds non-repeated status until unloading the item to measured. The AD-4322AMKII detects the unloaded status when weighing value is below the low limit set by the F-15 key.

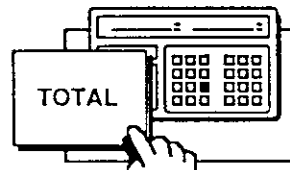

- When you press the **TOTAL** key, the main memory TOTAL is displayed. Then, pressing the **ENTER** key will display the number of 'In' (inputs) count. Press the **ENTER** key again to exit..

Viewing All of the Code Set Values

Step 1.

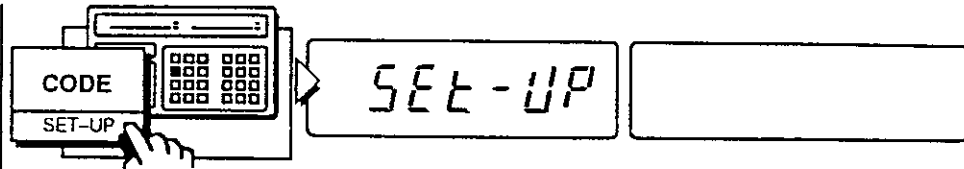

- From the weighing mode, press and hold the  key for five seconds until "SET-UP" appears.

Step 2.

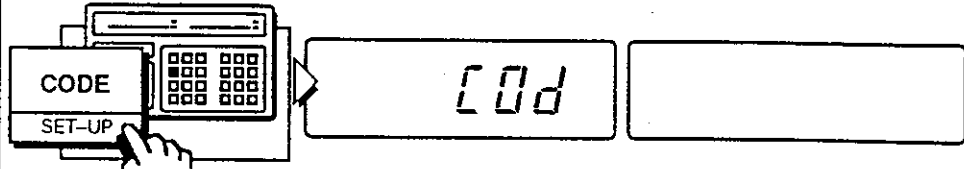

- Press the  key again.
- "COdE" (code) will be displayed.

Step 3.

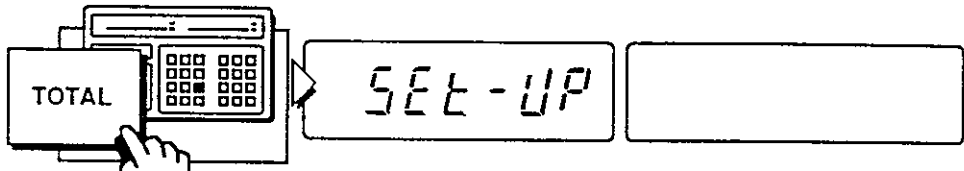

- Press the  key.
- "SET-UP ALL" will be displayed..

When the optional printer is installed or an external printer is connected, press the  key at this step to printout code setting value and mode setting status.

Step 4.

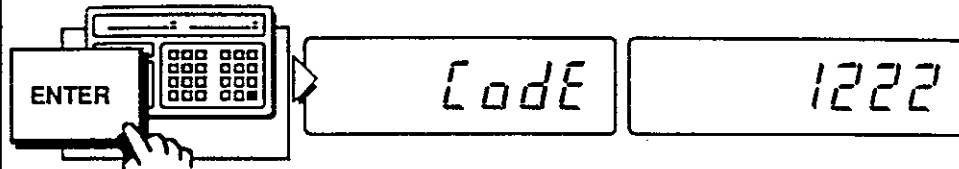

- ▶ Press the **ENTER** key.
- The first code number that has a Code Tare, Low limit Setpoint, High limit Setpoint, or Code Total will be displayed. (for example, code set number 1222)

Step 5.

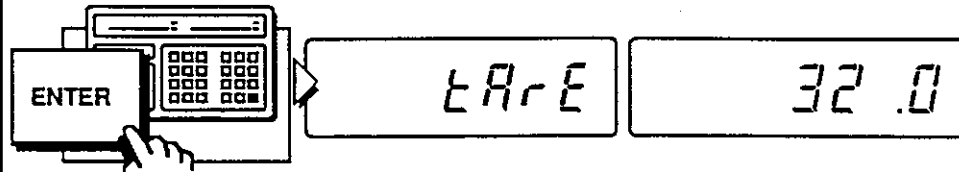

- ▶ Press the **ENTER** key.
- The Code Tare weight for that code number will appear on the right display. (for example 32.0kg is the Code Tare weight of code set 1222)

Step 6.

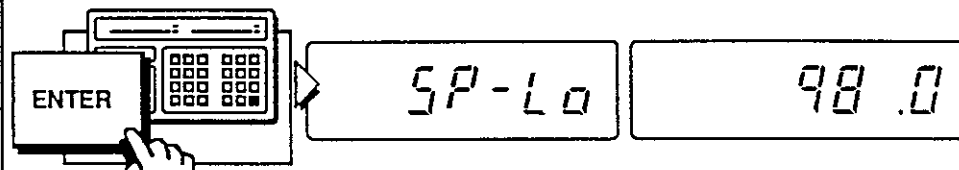

- ▶ Press the **ENTER** key.
- The Code Low limit Setpoint for that code number will appear on the right display. (for example 98.0kg is the Code Low limit Setpoint of code set 1222)

Step 7.

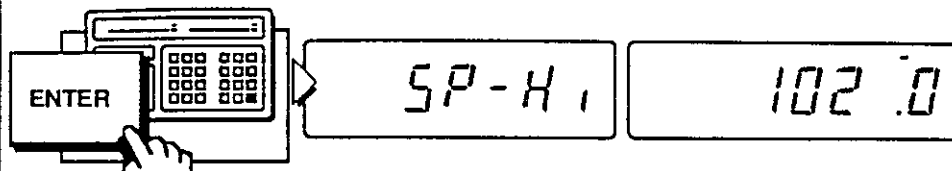

▶ Press the **ENTER** key.

○ The code High limit Setpoint for that code number will appear on the right display. (for example 102.0kg is the Code High limit Setpoint of code set 1222)

Step 8.

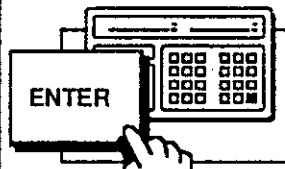

▶ Continue to press the **ENTER** key until you have viewed all the Code Set Values desired.

Step 9.

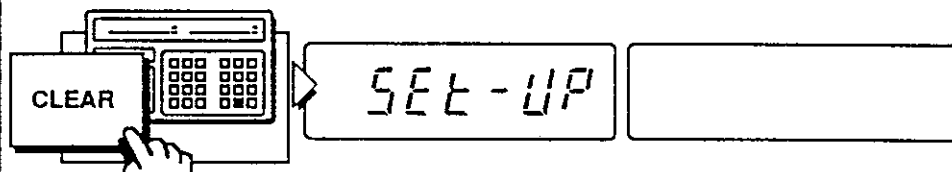

▶ Press the **CLEAR** key to escape to the Set-up mode when finished.

Step 10.

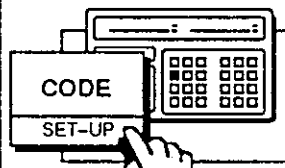

▶ Press and hold the **M+** key for five seconds until the display returns to the weighing mode.

To Clear Code Set Values

Step 1.

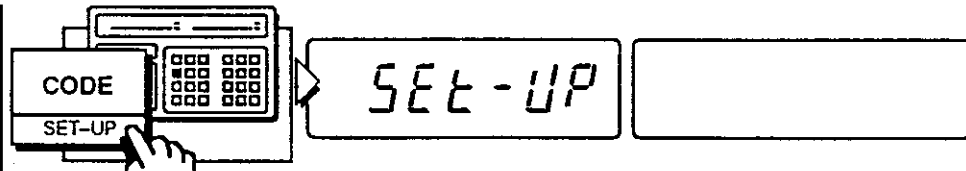

- From the weighing mode. Press and hold the **ENTER** key for five seconds until "Set-UP" appear.

Step 2.

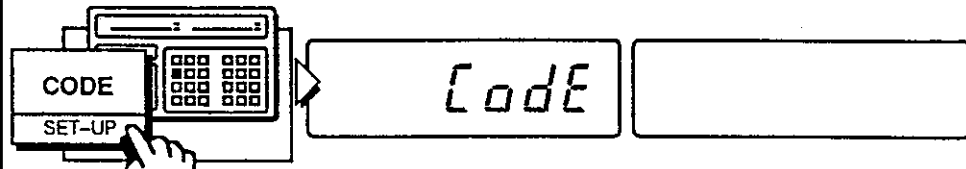

- Press the **ENTER** key again.
- "COdE" (Code) will be displayed.

Step 3.

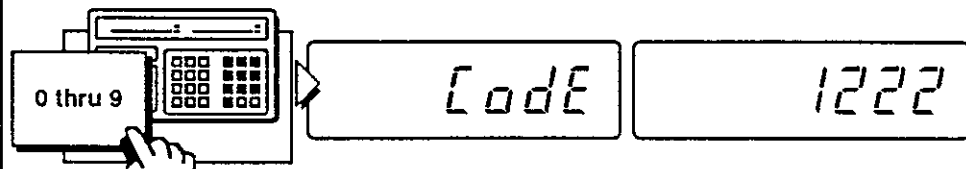

- Input code number to be clear using ten-key pad. (example: 1222).

Press and hold the **ENTER** key, then press the **CLEAR** key.

By using these keys, Tare, Low Limit Setpoint, High Limit Setpoint, Code Total or number of CodeTotal Inputs data will be cleared.

Step 4.

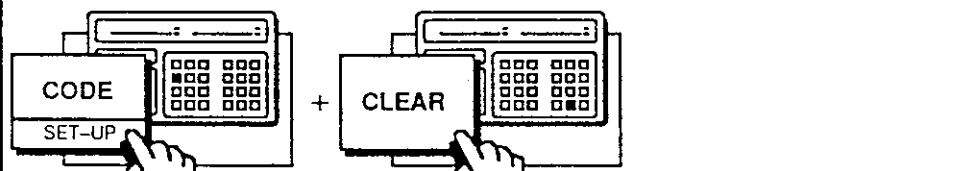

- "COdE CLEAR" (Code Clear) will be displayed briefly.

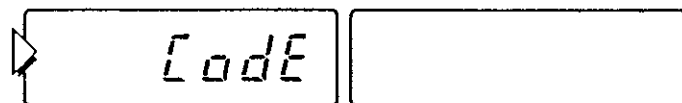

If you wish to clear more code sets at this time, repeat from step 2.

Step 5.

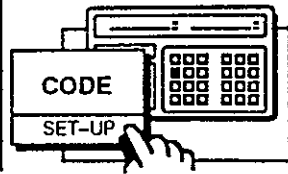

Press and hold the **ENTER** key for five seconds until the display returns to the weighing mode.

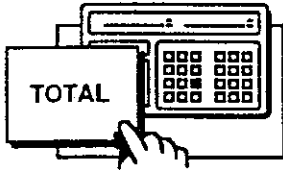

- When you press the **TOTAL** key, the main memory TOTAL is displayed. Then, pressing the **ENTER** key will display the number of 'In' (inputs) count. Press the **ENTER** key again to exit.

Adding/Subtracting to the Main Memory TOTAL

Step 1.



Display Examples

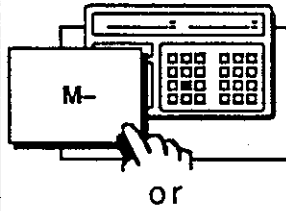

▶ While an object's weight is being displayed, press the **M+** key to add it to the main memory TOTAL, or the **M-** key to subtracted it from the main memory TOTAL. You will also be adding, or subtracting one to the 'In' inputs count.

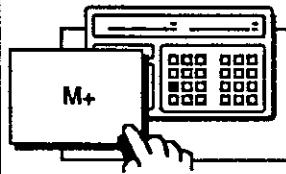

- The main memory TOTAL weight will be displayed on the right display panel briefly.

Step 2.

You will return to the weighing mode.

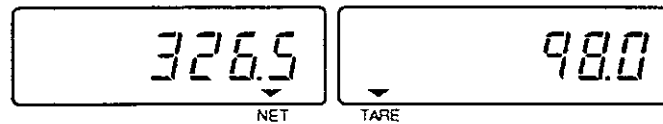

Display Example

Main Memory TOTAL OVERFLOW



The main memory TOTAL does have limits. For weight: -9999999 → 99999999, weighing events: -9999 → 99999.

Display



- When a main memory TOTAL overflow does occur, you will see the above display and will not be allowed to add further to the TOTAL. The last total remains in the memory.

Display

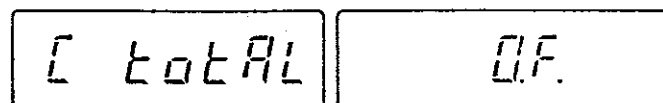

- If you are using the code function and a CODE TOTAL overflow occurs, you will see the above display and will not be allowed to add further to the CODE TOTAL. The last total remains in the memory. **☑**

Viewing the Main Memory TOTAL

Step 1.



Display Example

- ▶ Press the **TOTAL** key.
- The main memory TOTAL will appear on the right display.

 When the optional printer is installed or an external printer in the Print Mode is connected, press the **PRINT** key at this step to print the main memory TOTAL (See page 80).

Step 2.



Display Example

- ▶ Press the **ENTER** key.
- The main memory TOTAL "in" (inputs, the number of times the **M+** (or **M-**) key was pressed to add/subtract to the main memory TOTAL) will appear on the right display.

Step 3.

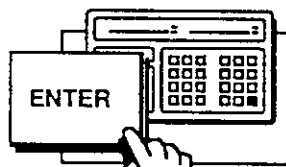

Press the **ENTER** key again to return to normal weighing. 

To CLEAR the Main Memory TOTAL

Step 1.



Display Example

- ▶ Press the **TOTAL** key.
- The main memory TOTAL will appear on the right display.

Step 2.

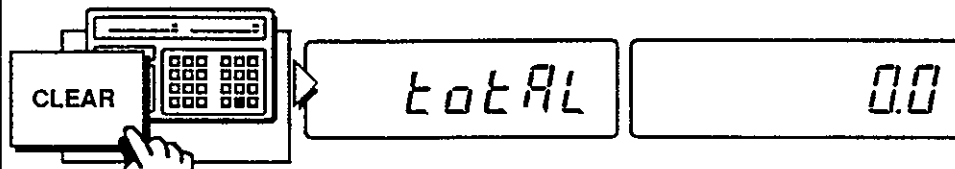

Display Example

- ▶ Press the **CLEAR** key.
- ⚠ If you mistakenly press the **CLEAR** key and the display clears, press the **CLEAR** key again immediately and the amount will return.

Step 3.

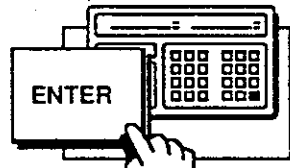

Press the **ENTER** key to return to the weighing mode. 

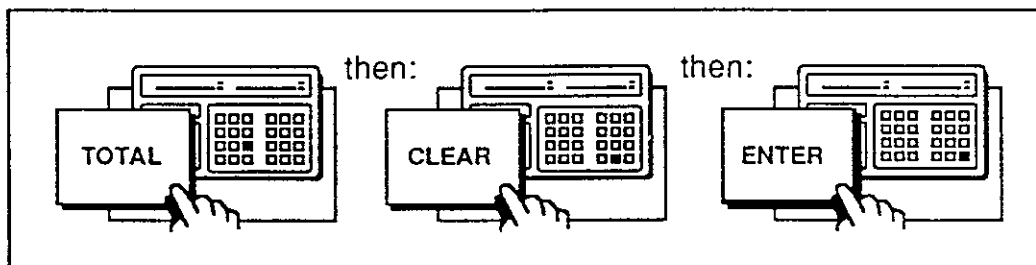

To Set Auto Main Memory TOTAL ADD Mode





When a weight is stable (Motion Detection (▼MD) annunciator goes OFF) the weight will be added automatically to the main memory TOTAL. The display must return to zero (less than 6 divisions) before another weight can be added.

⚠ When using Automatic TOTAL Add Mode and the code function (see page 54) you will be adding automatically to both the main memory TOTAL and the CODE TOTAL.

⚠ This feature will not work if F-Function F-6 (MOTION DETECTION CONDITION, see p. 137) is set at '0' or '10'.

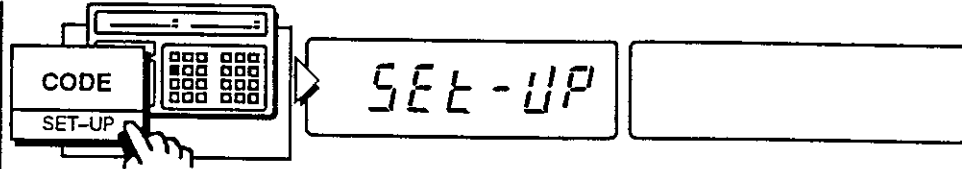
Step 1.



▶ From the weighing mode, press and hold the  key for five seconds until "SEt-UP" appears.

Step 2.

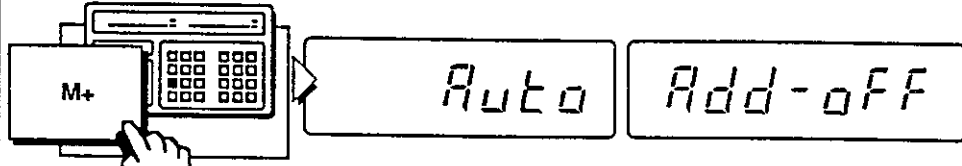

▶ Press the  key.
 ○ Either "Auto Add-oFF" (Automatic Adding Off) or "Auto Add-on" (Automatic Adding On) will be displayed, depending the last setting.

Step 3.

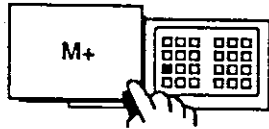

Use the  key to switch between "Auto Add-oFF" (Automatic Adding Off) and "Auto Add-on" (Automatic Adding On). Stop at the setting desired.

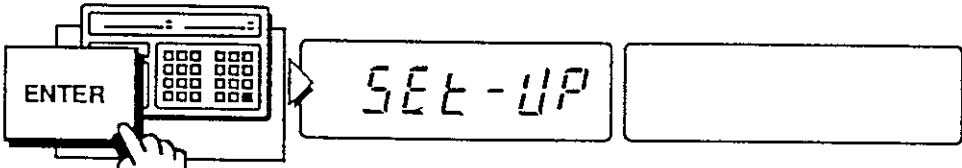

Step 4.



▶ When you have the correct display, press the  key. "SEt - UP" will be displayed.

Step 5.



Press and hold the  key for five seconds until the display returns to the weighing mode. 

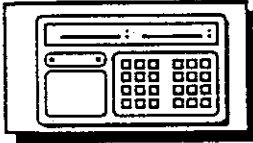

AD-4322AMKII Weighing Indicator

The Comparator Function



The Comparator Function





The AD-4322AMKII has the ability to be used as a simple weighing comparator, or by using the External I/O, as part of a sophisticated accept-reject automated system.

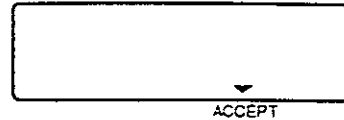

- To use the Comparator, you must enter the low limit setpoint (UNDER) and high limit setpoint (OVER) having either positive or negative value into the Comparator memory (or a Code Memory Set).
- Once those setpoints have been entered, the comparator can be turned On or Off.
- When the Comparator is On, and the setpoints have been entered, one of the three display annunciators ▼UNDER, ▼ACCEPT or ▼OVER will come On when an object is weighed.



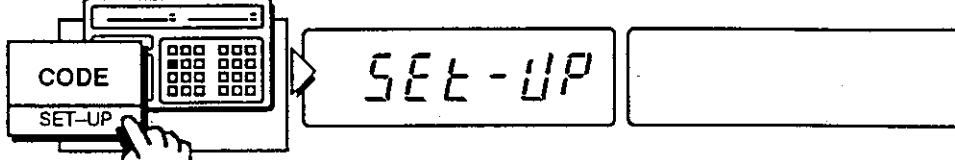

To Store Comparator Setpoints

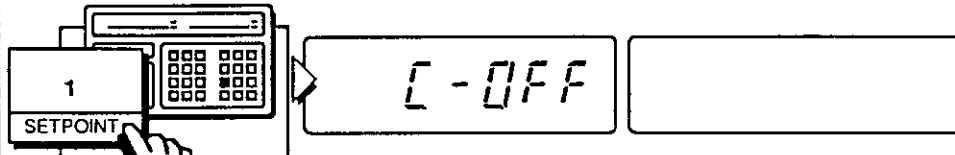
- Prelim. Know the Comparator setpoint value(s) to be entered. -
- ❑ Example: If an object should weigh 100kg, but anywhere in the range of 98kg to 102kg is okay, then we will set:
below 98kg as Under and
above 102kg as Over.

- Step 1. 
- ▶ From the weighing mode, press and hold the  key for five seconds until "SET-UP" appears.

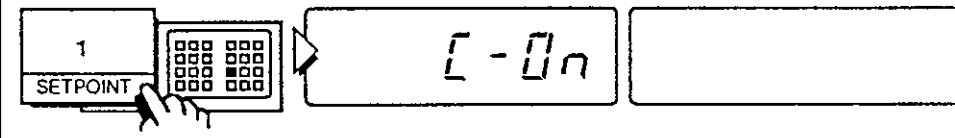
- Step 2. 
- ▶ Press the  key.
 - Either "C-Off" (Comparator Off) or "C-On" (Comparator On) will be displayed, depending the last setting.

- Step 3. 
- ▶ If "C-OFF" (Comparator Off) is displayed, press the  key to switch to "C-On" (Comparator On).

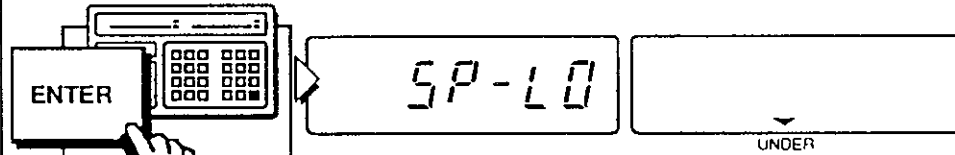
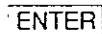
- Step 4. 
- ▶ When the "C-On" (Comparator On) is displayed, press the  key.
 - "SP - LO" (Setpoint - low) will be displayed and the ▼UNDER annunciator will come On.

Step 5.

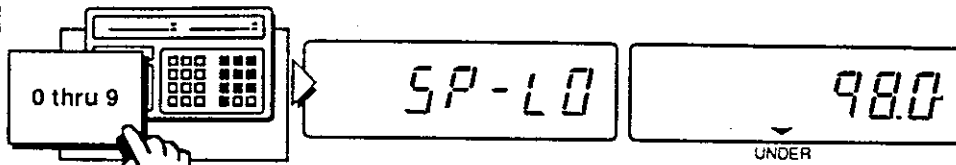

Display
Example

- ▶ Use the 10-key pad to enter in the new low limit setpoint (example: 98kg).
- The low limit value will be shown on the right display.
When setting the negative value to the setpoint, input numeral data using the ten-key pad and press the **M+** key.

Zero is also available as a setting value. When there is no need to set the value, press the **CLEAR** key for blank.

Step 6.

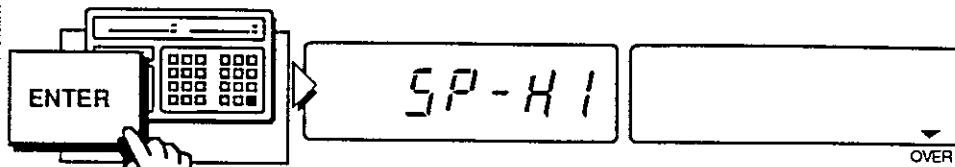

- ▶ When the correct low limit setpoint is displayed, press the **ENTER** key.
- "SP - HI" (high limit setpoint) will be displayed and the **▼OVER** annunciator will come On.

Step 7.

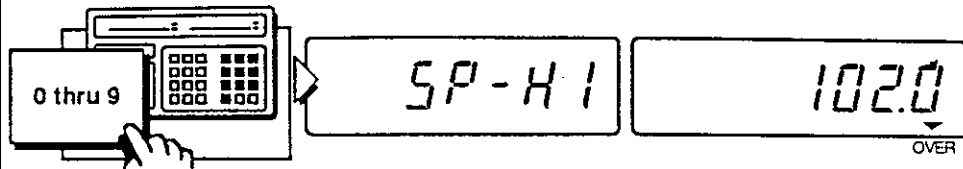

Display
Example

- Use the 10-key pad to enter in the new high limit setpoint (example: 102kg).
 - The low limit value will be shown on the right display.
When setting the negative value to the setpoint, input numeral data using the ten-key pad and press the **[M-]** key.
- Zero is also settable as setting value. When no need to set the value, press the **[CLEAR]** key for blank.

Step 8.

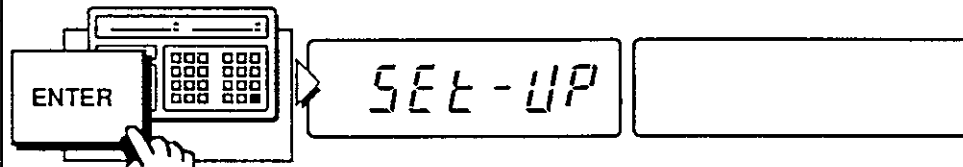

- When the correct high limit setpoint is displayed, press the **[ENTER]** key.
- ""SET - UP"" will be displayed.

Step 9.

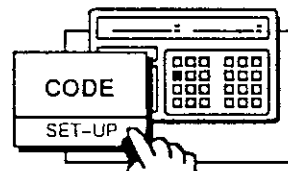

Press and hold the **[CODE SET-UP]** key for five seconds until the display returns to the weighing mode. **[V]**

Turning the Comparator ON or OFF

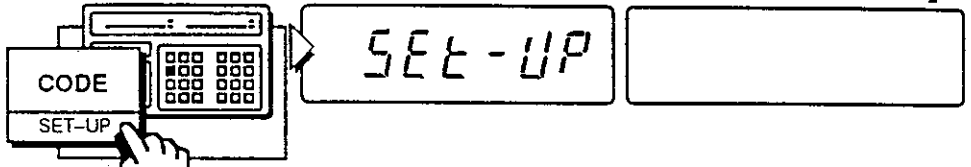
Step 1. 

- ▶ From the weighing mode, press and hold the **CODE SET-UP** key for five seconds until "SEt-UP" appears.

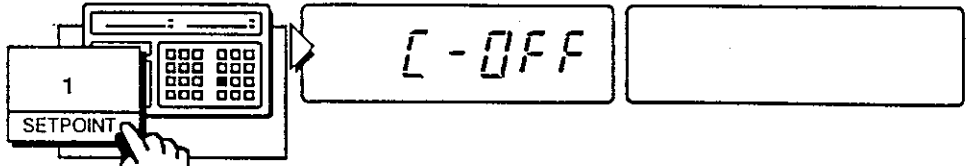
Step 2. 

- ▶ Press the **SETPOINT** key.
- Either "C-OFF" (Comparator Off) or "C-On" (Comparator On) will be displayed, depending the last setting.

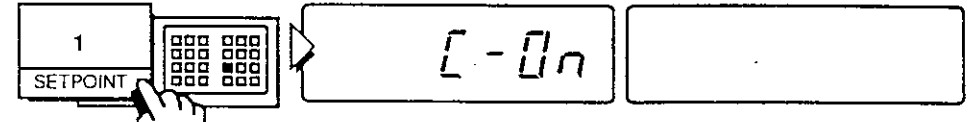
Step 3. 

- ▶ Use the **SETPOINT** key to switch between "C-OFF" (Comparator Off) and "C-ON" (Comparator On). Stop at the setting you want.

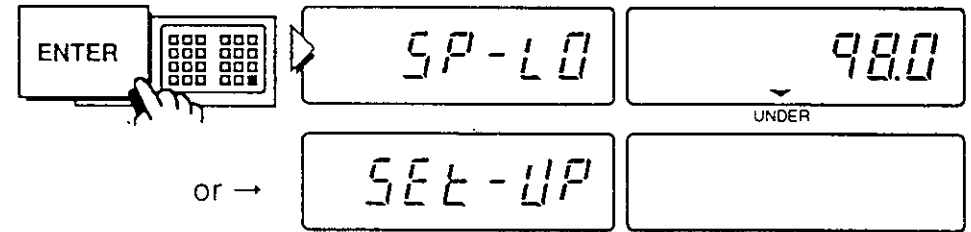
Step 4. 

Display Examples

- ▶ When you have the correct display, press the **ENTER** key.
- If you had turned the comparator On ("C-ON"), then "SP-LO" (low limit setpoint) will be displayed. In this case press the **ENTER** key twice until "SEt-UP" is displayed.
- If you had turned the comparator Off ("C-OFF"), then "SEt-UP" will be displayed.

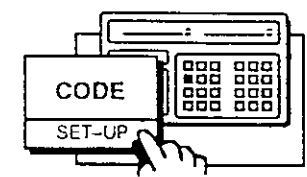
Step 5. 

Press and hold the **CODE SET-UP** key for five seconds until the display returns to the weighing mode. 

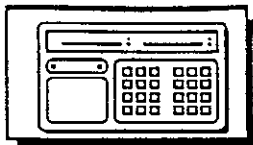

AD-4322AMKII Weighing Indicator

The ID/TARE Function



The I.D./Tare Function



- ❑ The AD-4322AMKII has the ability to store and recall 50 Tare weights in memory by eight - digit I.D. (identification) number.
- ❑ You will have to have an I.D. number for each number that is stored, it is used to later recall that Tare value.
- ❑ The Tare weights can be entered by weighing the tare container, or digitally via the 10-key pad.



To Store ID/Tare

Step 1. Have an empty TARE container or, know the TARE weight value to be entered (example: a 98kg container) and have an I.D. number to enter.

Step 2.

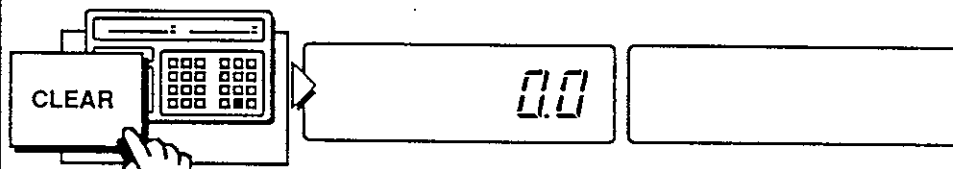

- ▶ Press the **CLEAR** key to clear the TARE display (if needed).

Step 3.
either a) or b)

a) Place the empty tare container on the weighing device (example: a 98kg container) and:

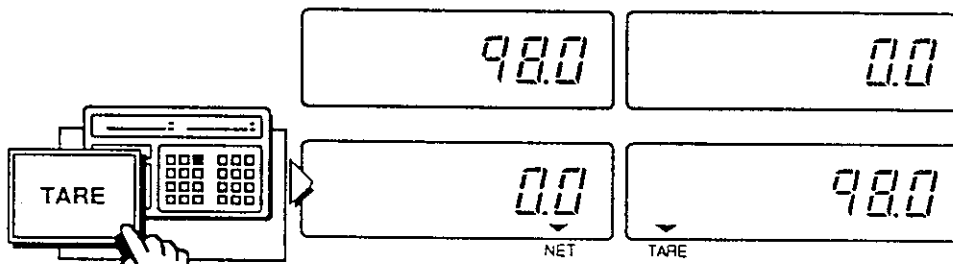

Display Examples

- ▶ Press the **TARE** key.

b) Use the 10-key pad to display the TARE weight (example: a 98kg container {=98.0, key-in: **9** **8** **0** }) and then:

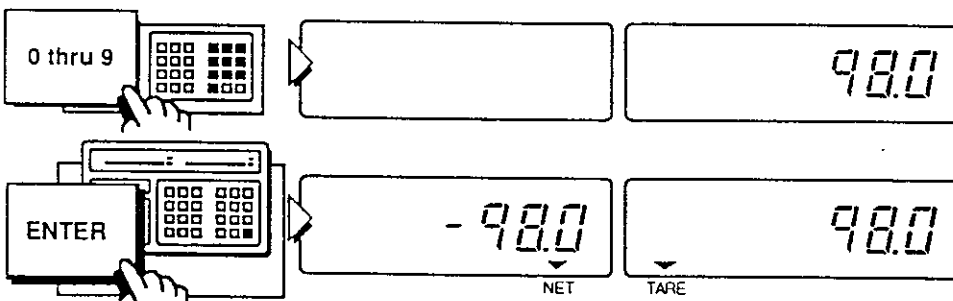

Display Examples

- ▶ Press the **ENTER** key.

Step 4.

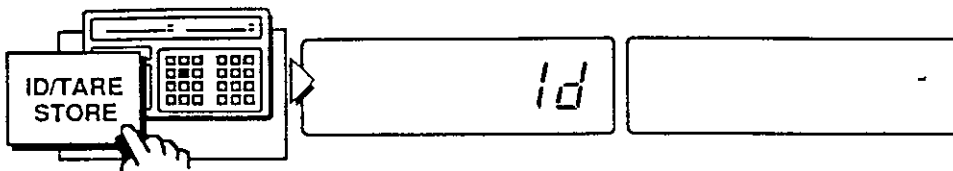

- ▶ Press the **ID/TARE STORE** key.
- "Id" will be displayed.

Step 5.

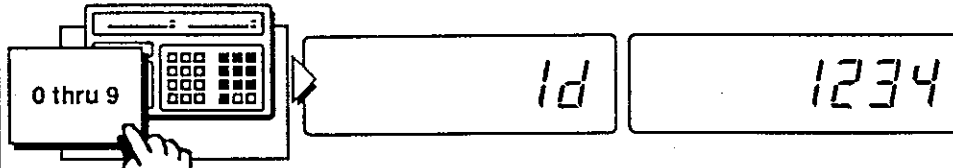

Display Example

- ▶ Use the 10-key pad to enter in the new I.D. number (for example I.D. 1234).

Step 6.

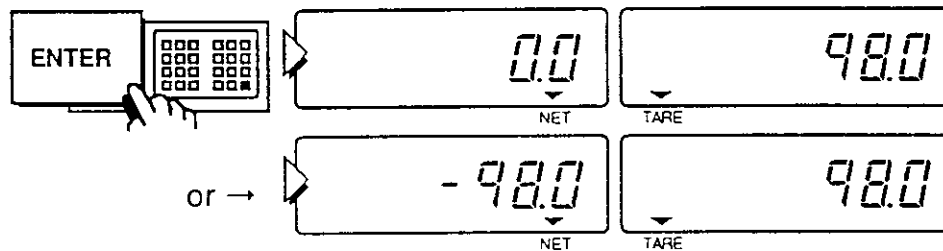

Display Examples

- ▶ Press the **ENTER** key.
- The TARE weight will be displayed on the right display panel (if you entered the TARE weight though the keyboard, the TARE value will show as a negative number on the left display).



If that I.D. number already has a TARE value stored in it - the display will flash. In that case you may:

a) Change to the new TARE weight:

- ▶ Press the **ENTER** key.

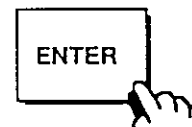

or b) Enter the new Tare weight into a new I.D. number:

- ▶ Press the **CLEAR** key.
- ▶ Key a new I.D. number
- ▶ Press the **ENTER** key.

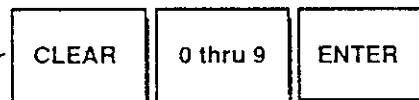

or c) Escape, no change:

- ▶ Press the **CLEAR** key.
- ▶ Press the **ENTER** key.

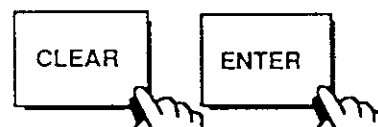

Step 7.

Continue weighing. **VI**

Weighing Using Stored ID/Tare (RECALLing an ID/Tare)

Step 1.

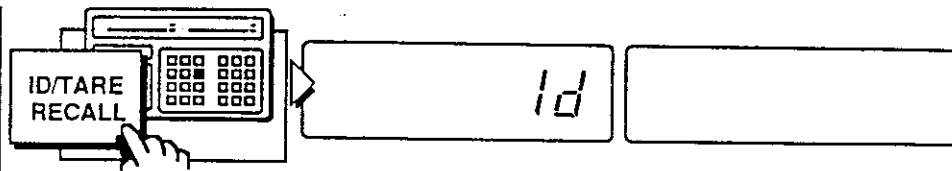

- ▶ Press the **ID/TARE RECALL** key.
- "Id" will be displayed (if an I.D. number has been previously entered, it will appear on the right display).

Step 2.

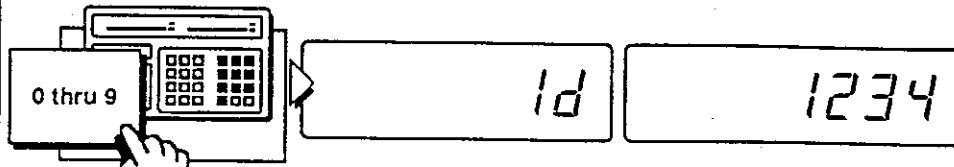

Display Example

- ▶ Use the 10-key pad to enter in the new I.D. number (for example I.D. 1234).

Step 3.

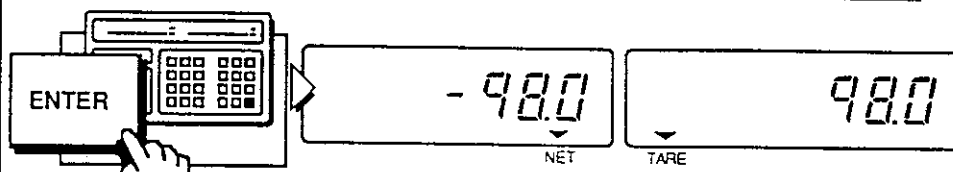

Display Example

- ▶ Press the **ENTER** key.
- The TARE weight will be displayed on the right display panel, and the TARE value will show as a negative number on the left display (if the I.D. container is on the weighing device, then the display should read "0.0"). The ▼TARE annunciator will come ON and the display will switch to NET mode (▼NET).

NOTE:

An "Error no Id" will occur if there is no TARE weight stored for the I.D. number you entered. Try again, or view the stored I.D. numbers to see if you have the correct number (see the next page).



Step 4. Continue weighing.

To EXIT from an ID/Tare



Simply clear the TARE weight display to exit an active ID/TARE by pressing the **CLEAR** key (or see p. 28).





Viewing All of the Stored ID/Tare's

Step 1.

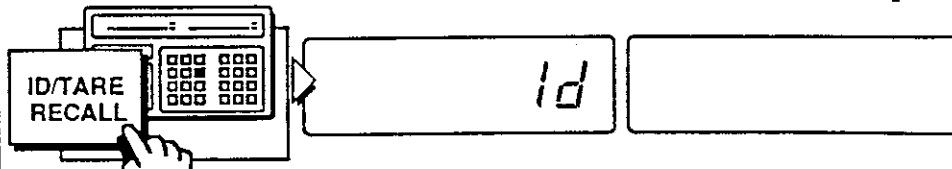

▶ Press the **ID/TARE RECALL** key.

○ "Id" will be displayed (if an I.D. number has been previously entered, it will appear on the right display).

Step 2.

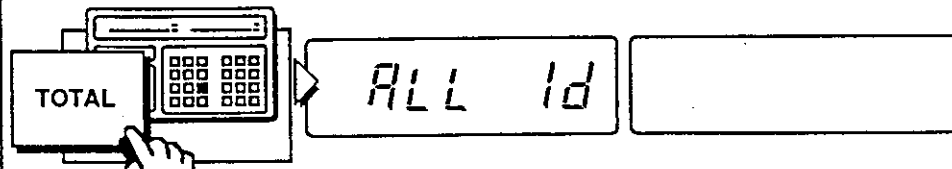

▶ Press the **TOTAL** key.

○ "ALL Id" will be displayed.



When the optional printer is installed or an external printer in the Print Mode is connected, press the **PRINT** key at this step to print the main memory TOTAL (See page 94)

Step 3.

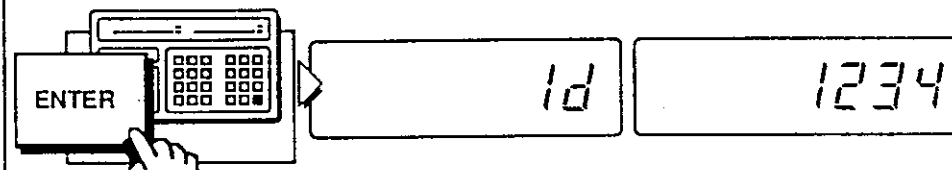

Display Example

▶ Press the **ENTER** key.

○ The first stored "Id" number will be displayed (ex: ID 1234).

Step 4.

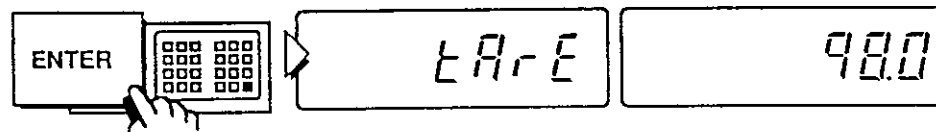

Display Example

▶ Press the **ENTER** key again.

○ The TARE weight will be displayed on the right display panel (for example, 98.0 is the TARE weight of I.D. 1234).

Step 5.



Continue to press the **ENTER** key until you have viewed the ID/TARE's desired.

Step 6.



Press the **CLEAR** key to escape to the normal weighing mode. **▼**

- Data is displayed from lowest I.D. number.

CLEARing a Stored ID/TARE



To clear a single ID/Tare, you will need to CLEAR the TARE weight. Follow the TO STORE ID/TARE section (see p. 47) but skip Steps 3 & 4 and after Step 7, do Step 7a.

To CLEAR All of the Stored ID/TARE's



This procedure clears all of the stored ID/Tare's at one time, there is no way to recover them. Use this feature carefully!

Step 1. Start with the display turned OFF.

Step 2. Press and hold the **SETPOINT** key, then press the **STANDBY OPERATE** key - release the keys.

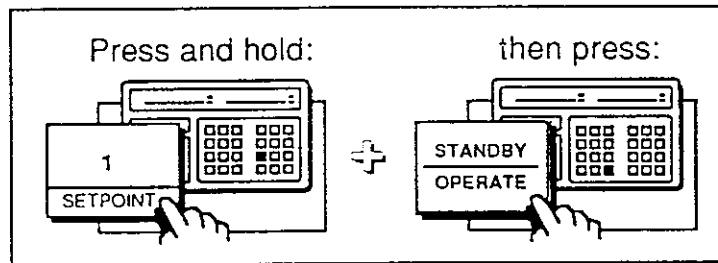

Display The displays come ON to normal weighing mode. All of the stored ID/Tare's will have been erased. 

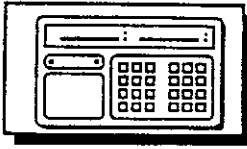

AD-4322AMKII Weighing Indicator.

The Code Function



Code Function Introduction



The AD-4322AMKII has the ability to store and recall 100 'sets' of weighing information by a eight-digit code number. We will refer to these as 'code memory sets'.

- ❑ These sets can contain: the code number, a TARE weight value, low limit setpoint, high limit setpoint, and a CODE TOTAL weight (with the number of inputs).
- ❑ You will have to have a code number for each Memory Set that is stored, it is used to later recall the Set.
- ⚠ When storing, the TARE weights can *only* be entered digitally via the 10-key pad.

Code Memory Set	
1	Code Number
2	<i>optiona</i> Tare Weight Value
3	<i>optiona</i> Low Limit Setpoint
4	<i>optiona</i> High Limit Setpoint
5	CODE TOTAL Weight
6	Number CODE TOTAL Inputs

The code number can be any number between 1 ~ 99999999.

A Tare weight is optional. If used, it will be overridden by any other Tare value entered after a Code Memory Set has been activated.

This is an optional low limit setpoint for the comparator. The UNDER annunciator will come On if the displayed weight is under this set limit.

This is an optional high limit setpoint for the comparator. The OVER annunciator will come On if the displayed weight is over this set limit.

While you are using the Code function, pressing the M+, or M-, key will add/subtract the amount to both the main memory TOTAL and to this CODE TOTAL

This is the number of 'in' inputs to the CODE TOTAL memory (M+/M- key was pressed).



Code Setting Flowchart

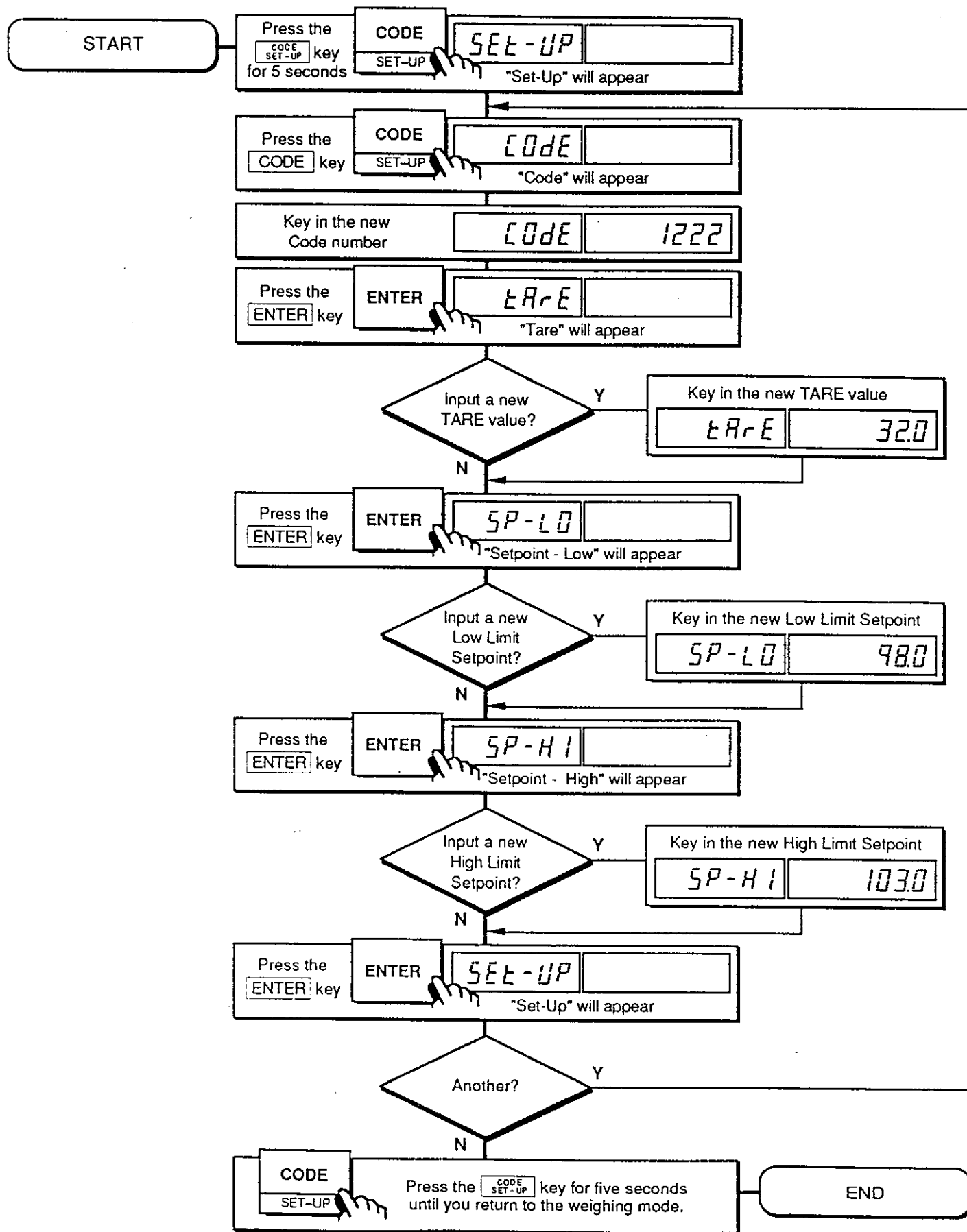



To Enter Code Set Values





This section is a detailed explanation of how to enter values into a new code set. A flowchart overview can be seen on the previous page. In this section we will create an example code set, you may substitute your own values if you wish. The example code set will contain the following values:

- Code number 1222
- 32kg TARE container
- 98kg low limit setpoint
- 102kg high limit setpoint.

Step 1. Know the code number to be entered, along with: TARE weight value, low limit setpoint and high limit setpoint if used. For example we will use the ones listed above.

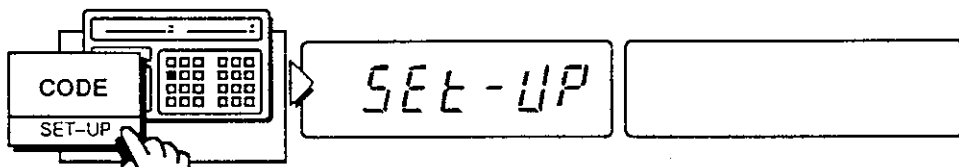
Step 2.



- From the weighing mode, press and hold the  key for five seconds until "SEt-UP" appears.

Step 3.

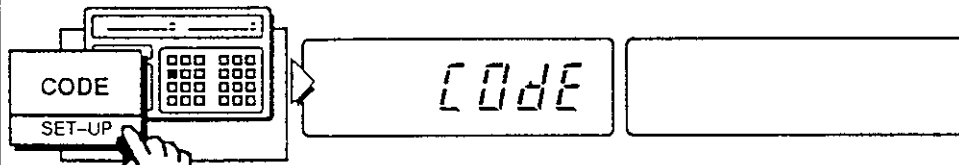

- Press the  key again.
- COdE" (Code) will be displayed.

Step 4.

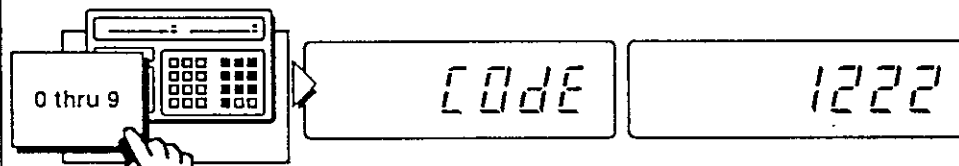

Display Example

- Use the 10-key pad to enter in the new code number (example: 1222).
- The code number will be shown on the right display.

Step 5.

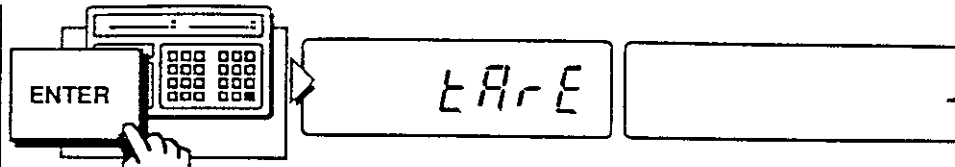

- When the correct code number is displayed, press the **ENTER** key.
- "tArE" (Tare) will be displayed.

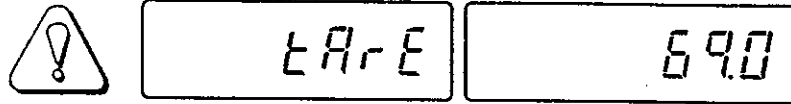

- If a TARE value appears without you inputting it, then the code number already has values stored in it. At this point you can either continue and input new values for the code set, or just press the **ENTER** key until you reach the "SEt-UP" display - then you may either go to Step 3 to start over with a new code number, or Step 12 to end.

Step 6.

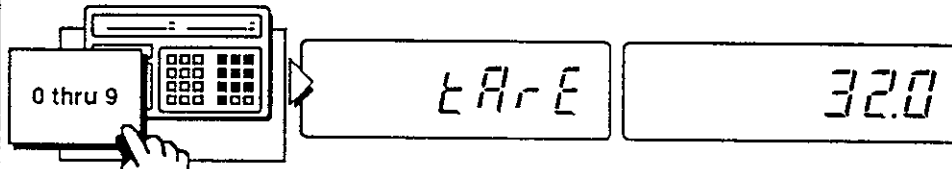

Display Example

- Use the 10-key pad to enter in the new TARE weight value. For example: 32kg tare container (if there is no TARE value to enter, skip to the next step).
- The TARE weight value will be shown on the right display.

Step 7.

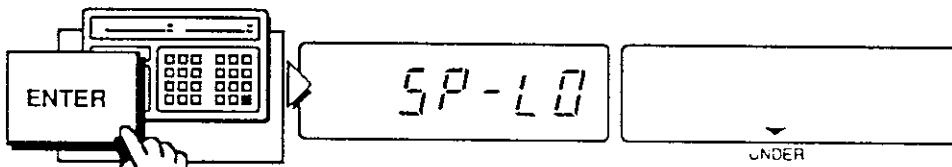

- When the correct TARE weight value is displayed, press the **ENTER** key.
- "SP - LO" (Setpoint - low) will be displayed and the ▼UNDER annunciator will come On.

Step 8.

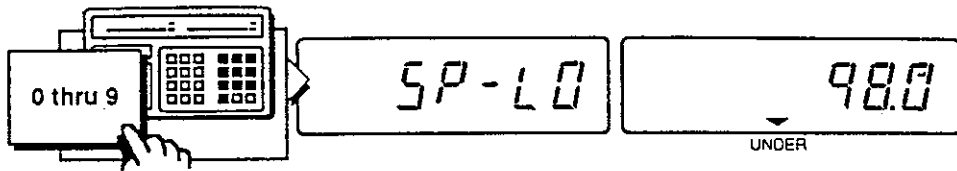

Display
Example

- ▶ Use the 10-key pad to enter in the new low limit setpoint. For example: 98kg. (if there is no low limit setpoint value to enter, skip to the next step).
- The low limit value will be shown on the right display.
When setting the negative value to the setpoint, input numeral data using the ten-key pad and press the **[M-]** key.
Zero is also settable as setting value. When no need to set the value, press the **[CLEAR]** key for blank.

Step 9.

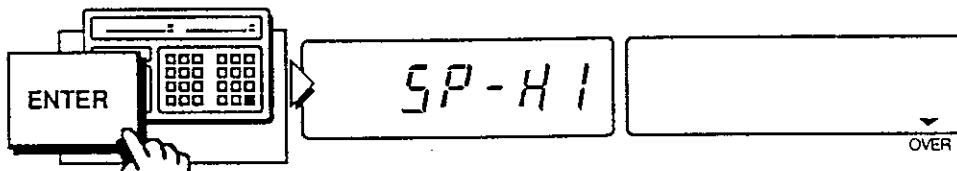

- ▶ When the correct low limit setpoint is displayed, press the **[ENTER]** key.
- "SP - HI" (high limit setpoint) will be displayed and the **▼OVER** annunciator will come On.

Step 10.

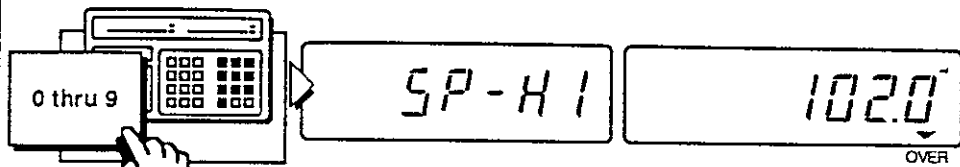

Display Example

- Use the 10-key pad to enter in the new high limit setpoint. For example: 102kg. (if there is no high limit setpoint value to enter, skip to the next step).
- The low limit value will be shown on the right display.

When setting the negative value to the setpoint, input numeral data using the ten-key pad and press the **[M]** key.

Zero is also available as a setting value. When there is no need to set the value, press the **[CLEAR]** key for blank.

Step 11.

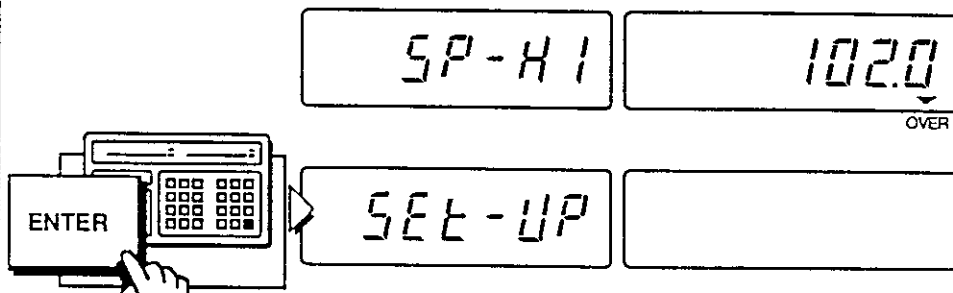

- When the correct high limit setpoint is displayed, press the **[ENTER]** key.
- "SEt - UP" will be displayed.



If you wish to enter more code sets at this time, repeat anew from Step 3. You may continue to enter additional new sets in this way - until you end the session by going to Step 12.

Step 12.

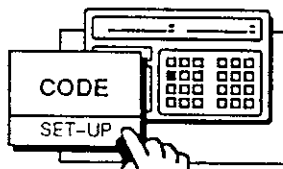

Press and hold the **[CODE SET-UP]** key for five seconds until the display returns to the weighing mode. **[M]**



Editing a Code Set



To change or clear a value in a code set, follow the example below which has the same flow as the CODE SETTING FLOWCHART on page 55. Simply remember that when a previously set value (if any) appears you can:

- Change it by using the 10-key pad to enter a new value, then pressing the **ENTER** key, or
- Clear it by pressing the **CLEAR** key, then pressing the **ENTER** key, or
- Have no change by pressing the **ENTER** key.

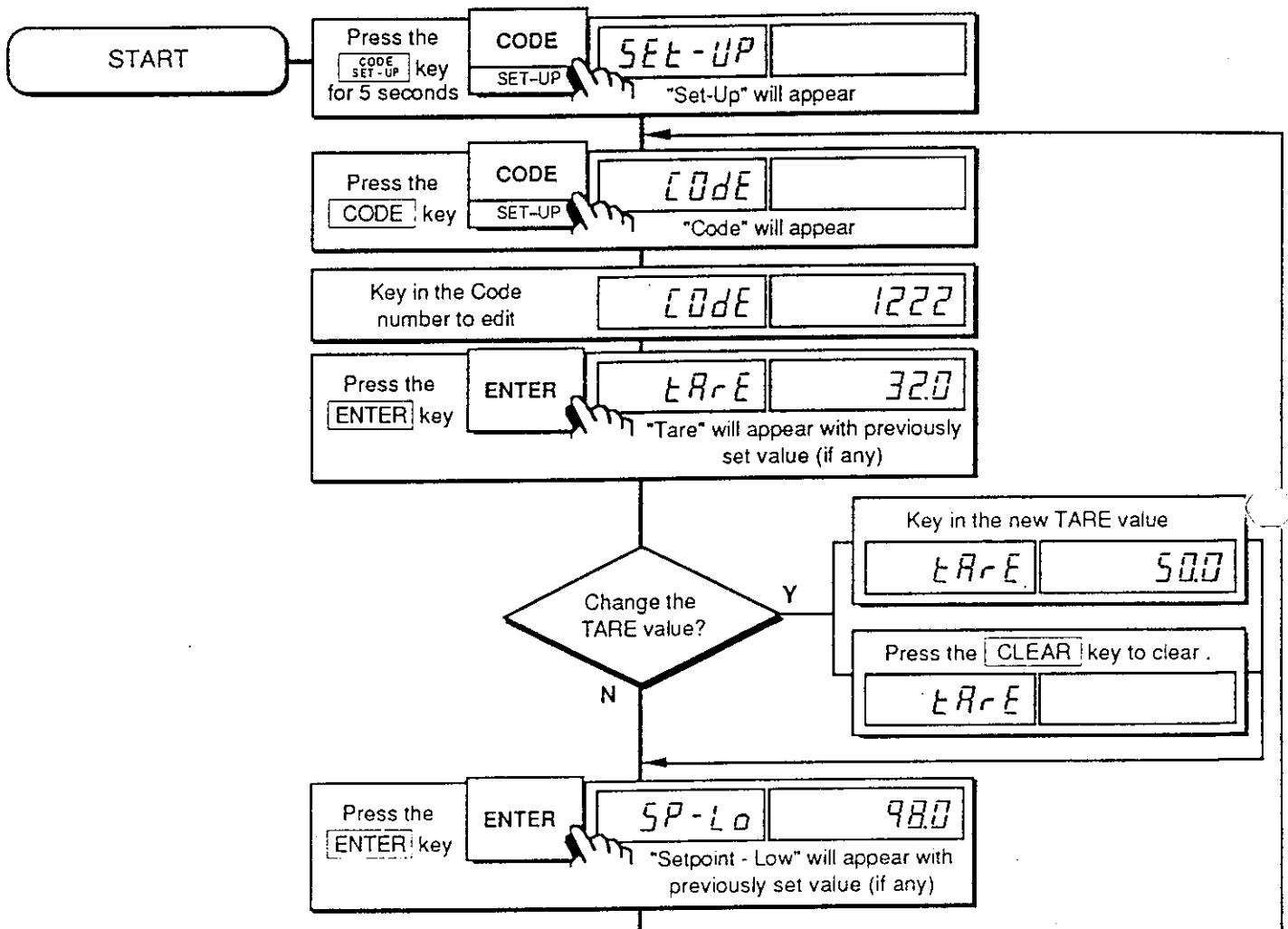

Viewing All of the Code Set Values

Step 1.

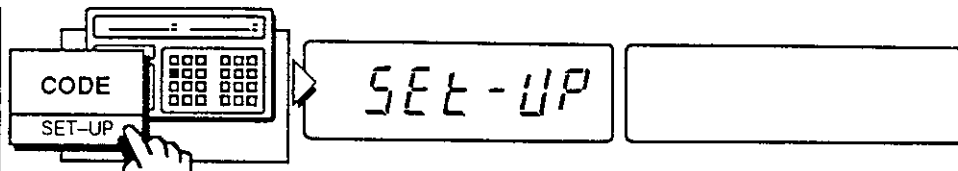

- ▶ From the weighing mode, press and hold the **CODE SET-UP** key for five seconds until "SET-UP" appears.

Step 2.

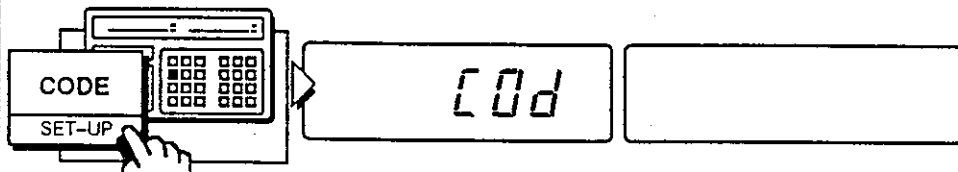

- ▶ Press the **CODE** key again.
- "COdE" (code) will be displayed.

Step 3.

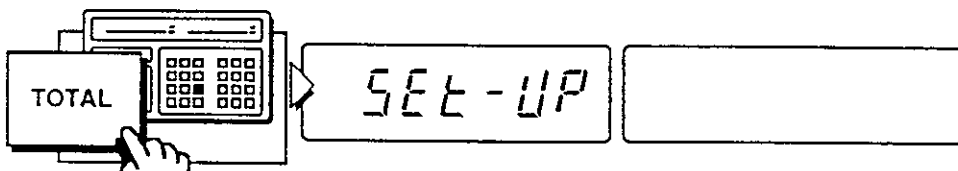

- ▶ Press the **TOTAL** key.
- "SET-UP ALL" will be displayed..

When the optional printer is installed or an external printer in the Print Mode is connected, press the **PRINT** key at this step to printout code setting value and mode setting status.

Step 4.

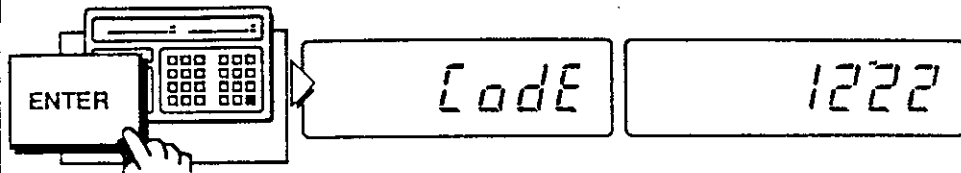

- ▶ Press the **ENTER** key.
- The first code number that has a Code Tare, Low limit Setpoint, High limit Setpoint, or Code Total will be displayed. (for example, code set number 1222)

Step 5.

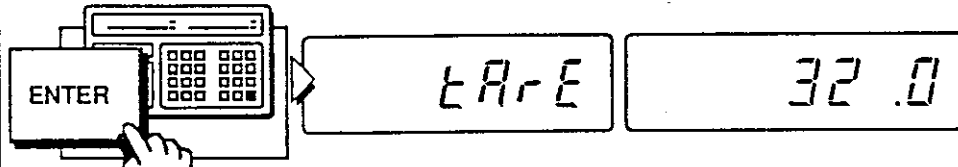

- ▶ Press the **ENTER** key.
- The Code Tare weight for that code number will appear on the right display. (for example 32.0kg is the Code Tare weight of code set 1222)

Step 6.

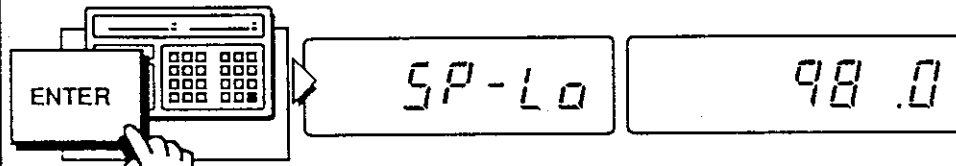

- ▶ Press the **ENTER** key.
- The Code Low limit Setpoint for that code number will appear on the right display. (for example 98.0kg is the Code Low limit Setpoint of code set 1222)

Step 7.

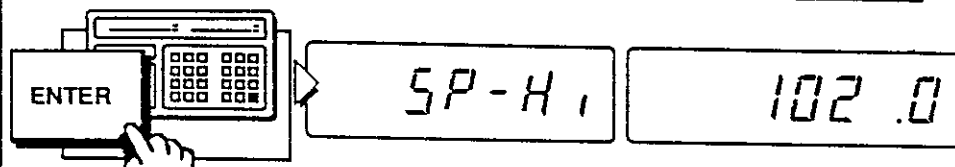

▶ Press the **ENTER** key.

○ The code High limit Setpoint for that code number will appear on the right display. (for example 102.0kg is the Code High limit Setpoint of code set 1222)

Step 8.



▶ Continue to press the **ENTER** key until you have viewed all the Code Set Values desired.

Step 9.

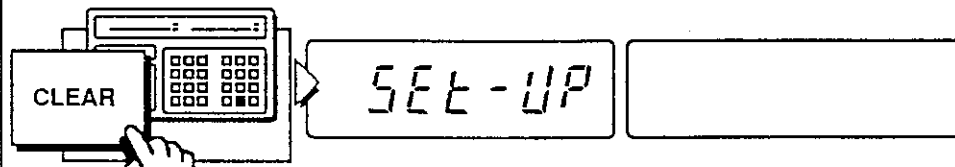

▶ Press the **CLEAR** key to escape to the Set-up mode when finished.

Step 10.

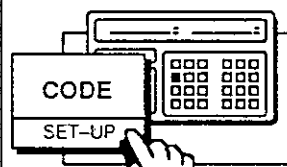

▶ Press and hold the **CODE SET-UP** key for five seconds until the display returns to the weighing mode.

✚ To Clear Code Set Values

Step 1.

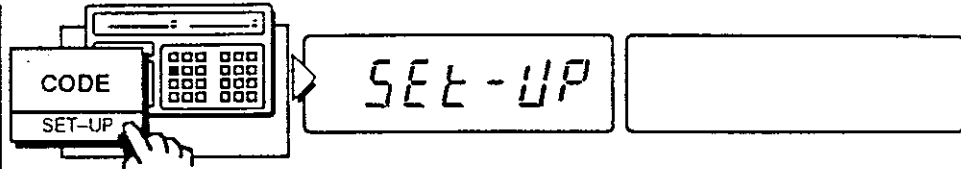

- ▶ From the weighing mode. Press and hold the  key for five seconds until "SEt-UP" appear.

Step 2.

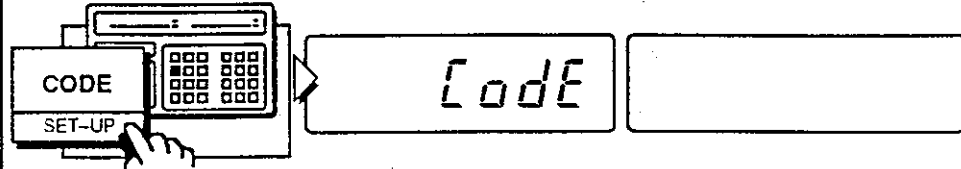

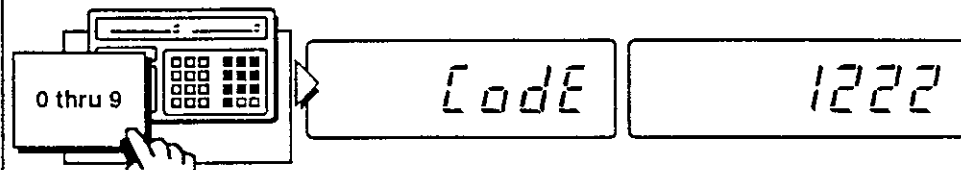

- ▶ Press the  key again.
- "COdE" (Code) will be displayed.

Step 3.



- ▶ Input code number to be clear using ten-key pad. (example: 1222).

Press and hold the  key, then press the  key.

By using these keys, Tare, Low Limit Setpoint, High Limit Setpoint, Code Total or number of CodeTotal Inputs data will be cleared.

Step 4.

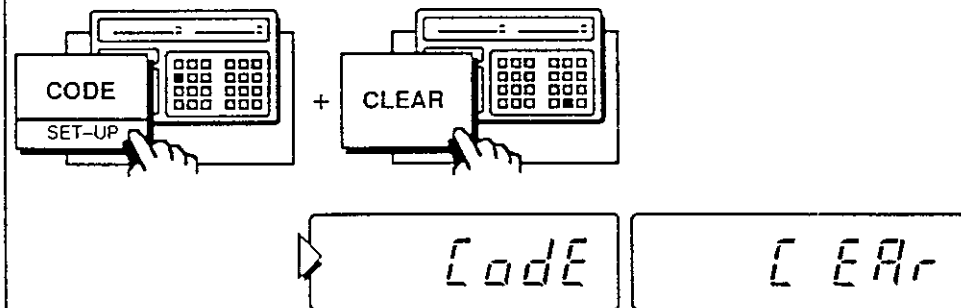



- "COdE CLEAR" (Code Clear) will be displayed briefly.

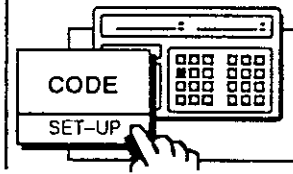

If you wish to clear more code sets at this time, repeat from step 2.

Step 5.



Press and hold the  key for five seconds until the display returns to the weighing mode.



Using The Code Function

The Code Function can be accessed in two different ways:



- a) Call up the Code Memory Set before you start the weighing event.
- b) Call up the Code Memory Set when the weight is already displayed.

Step 1.

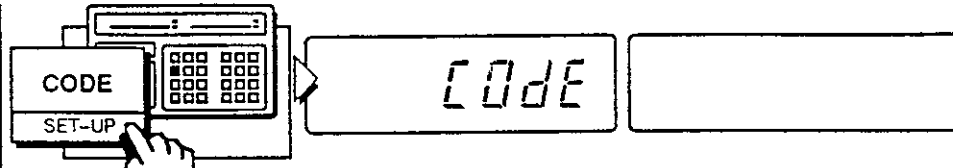

- Press the **CODE** key.
- "COdE" (Code) will be displayed.

Step 2.

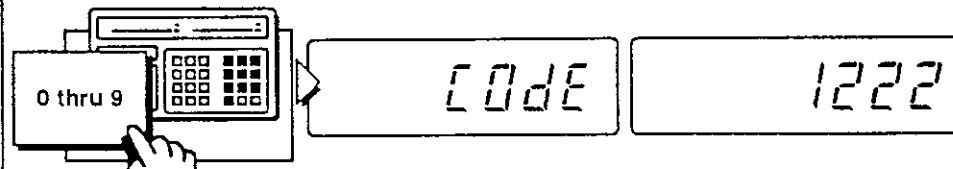

Display Example

- Use the 10-key pad to enter in the code number (example: 1222).
- The code number will be shown on the right display.

Step 3.

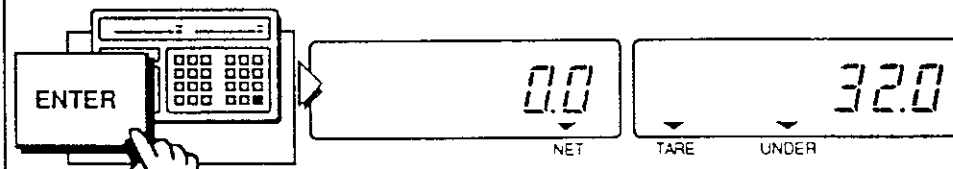

Display Example

- When the correct code number is displayed, press the **ENTER** key.
- You will return to the weighing mode and:
 - If there is a Tare weight stored in the Code Memory Set, it will now be shown on the right display and the ▼TARE annunciator will come ON and the display will switch to NET mode (▼NET).
 - If there are setpoint values (under, over) stored in the Code Memory Set and the comparator is turned ON - then one of the Comparator annunciators will come ON (▼UNDER, ▼ACCEPT, ▼OVER).



Cancel of Code Setting

- Input code number using keys as described page 66.

The Code Set Value (Tare, Low Limit Setpoint, High Limit Setpoint) of input code number will be recalled.

Step 1.

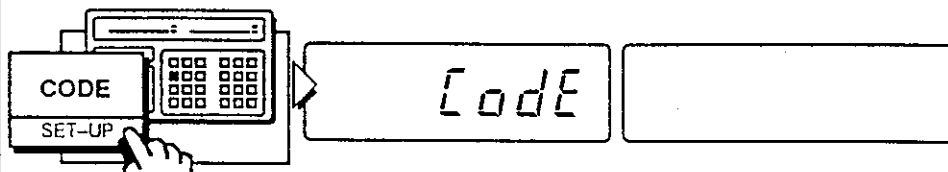

- ▶ Press **ENTER** key.
- The "COdE" (Code) will appear on the left display, and code number (XXXX) being set will appear on the right display.

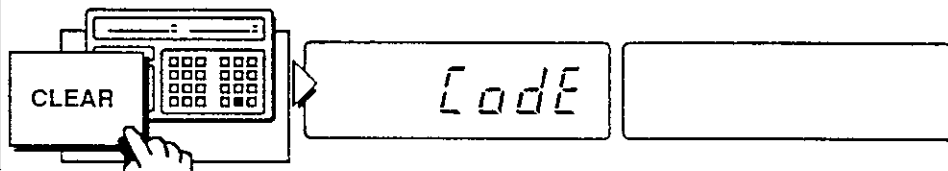

- ▶ Press the **CLEAR** key.
- The code number on the right display will be erased.

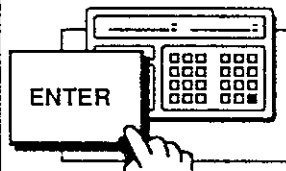

- ▶ Press the **ENTER** key.
- The code has been set is canceled, and the AD-4322AMKII returns to Normal Weighing Mode.

If a code set value has been recalled, the Tare value will be kept if another code set without a Tare value is recalled. This is also true if an empty set is recalled, to eliminate a Tare value, press **CLEAR** key, then **ENTER** key.

- ⚠ Recalling an empty set allows code total of the empty set. The empty set being a product for which there was no high or low limit, or Tare weight. But, for which a total must be kept.

Example: You must track several products. Some of the products have known weights in a container. But, one product is variable.

Code #	Item	Lot	TARE	Weight	
1	Beans	Case	4lb	28lb	24/1lb Bag
2	Rice	Case	6lb	126lb	12/10lb Bag
3	Banana	Bunch	-	-	-
4	Freshcom	Case	3.8	-	-

Using the Code Total Memory



Along with optional Tare weight and/or comparator setpoints, the code sets can contain a running total (code Total) and the number of times, 'in' (inputs), the memory has been added to (see page 54).

⚠ Please remember that you will be adding/subtracting not only to the CODE TOTAL, but also the AD-4322AMKII's main memory TOTAL.

Adding/Subtracting to the Code Total

Prelim: You must have a code set active if you want to add to its memory (see page 66).

Step 1.

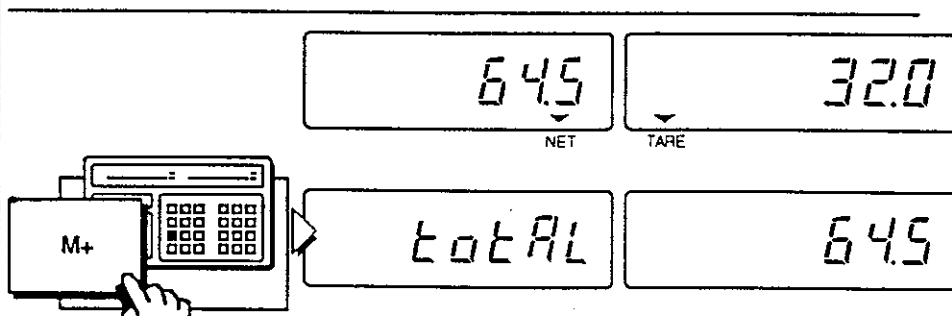

Display Examples

▶ While an object's weight is being displayed, press the **M+** key to add it to the CODE TOTAL (and main memory TOTAL), or the **M-** key to subtracted it from the CODE TOTAL (and main memory TOTAL). You will also be adding, or subtracting one to the 'in' inputs counts.

○ The main memory TOTAL weight will be displayed on the right display panel briefly.

Step 2.

You will return to the weighing mode.

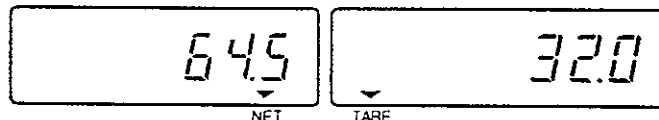

Display Example

Code Total Overflow



Both the CODE TOTAL and the main memory TOTAL have limits. For both, the overflow weight is: -9999999 → 99999999, and for weighing events: -9999 → 99999.

Display

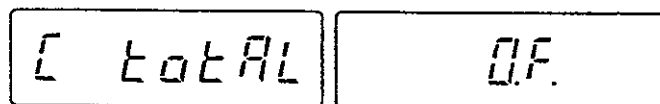

- When a CODE TOTAL overflow does occur, you will see the above display and will not be allowed to add further to the CODE TOTAL. The last total remains in the memory. **VI**



Viewing a Code Total

Prelim: You must have a code set active if you want to add to its memory (see page 66).

Step 1.

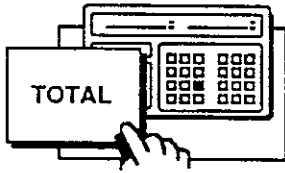

TOTAL

128.0

Display Example

- Press the **TOTAL** key.
- The main memory TOTAL will appear on the right display.

Step 2.

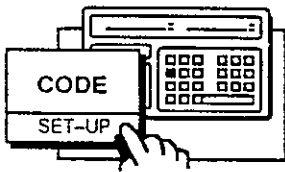

CODE

1222

Display Examples

[TOTAL

64.5

- Press the **CODE** key.
- The code number you are presently in will appear on the right display for a few seconds, then:
- The CODE TOTAL will appear on the right display.

 When the optional printer is installed or an external printer in the Print Mode is connected, press the **PRINT** key at this step to print the main memory TOTAL (See page 80).

Step 3.

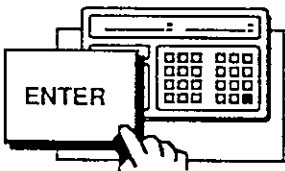

[TOTAL

in 1

Display Example

- Press the **ENTER** key.
- The CODE TOTAL "in" (inputs, the number of times the **M+** (or **M-**) key was pressed to add/subtract to the CODE TOTAL) will appear on the right display.

Step 4.

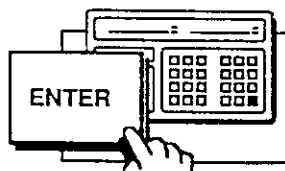

- Press the **ENTER** key again to return to normal weighing. 

Viewing All of the code Total's

Step 1.

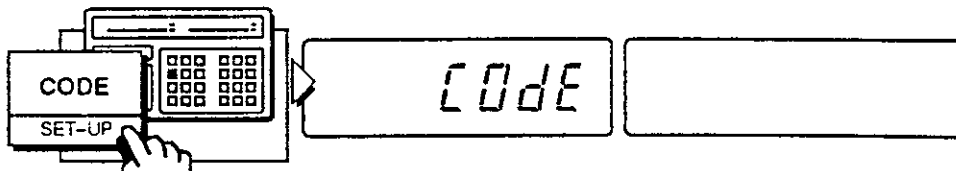

- Press the **CODE** key.
- "COdE" (Code) will be displayed.

Step 2.

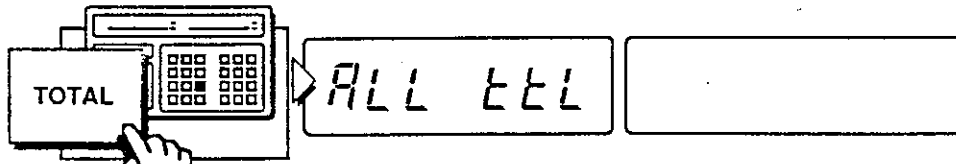

- Press the **TOTAL** key.
- "ALL tL" (All CODE TOTALS) will be displayed.



When the optional printer is installed or an external printer in the Print Mode is connected, press the **PRINT** key at this step to print the main memory TOTAL (See page 80).

Step 3.

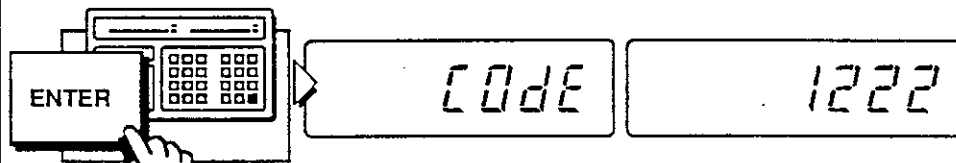

Display Example

- Press the **ENTER** key.
- The first code number that has a CODE TOTAL will be displayed (for example, code set number 1222).

Step 4.

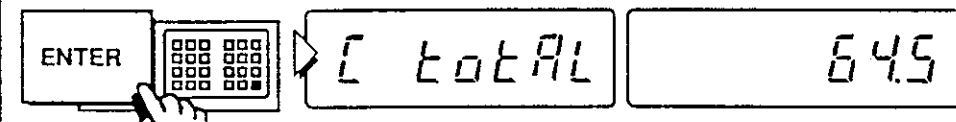

Display Example

- Press the **ENTER** key again.
- The CODE TOTAL weight for that code number will appear on the right display panel (for example, 64.5kg is the CODE TOTAL weight of code set 1222).

Step 5.

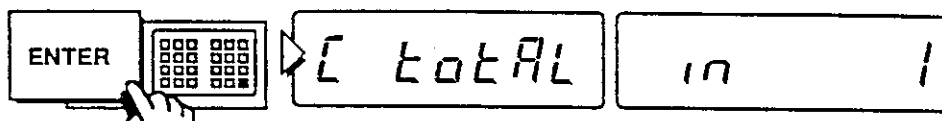

Display Example

- Press the **ENTER** key again.
- The CODE TOTAL "in" (inputs, the number of times the **M+** (or **M-**) key was pressed to add/subtract to that CODE TOTAL) will appear on the right display.

Step 6.

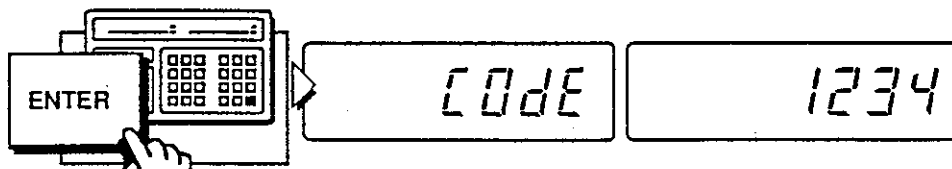

Display Example

- Press the **ENTER** key again.
- The next code number that has a CODE TOTAL will be displayed (for example, code set number 1234).

Step 7.



Continue to press the **ENTER** key until you have viewed all the CODE TOTAL's desired.

Step 8.

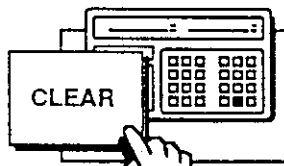

Press the **CLEAR** key to escape to the normal weighing mode when finished.

Data to be displayed is ordered from the smallest code number to the largest code number.

To Clear a Code Total

Prelim: You must have a code set active if you want to CLEAR its CODE TOTAL.

Step 1.



Display Example

- Press the **TOTAL** key.
- The main memory TOTAL will appear on the right display.

Step 2.

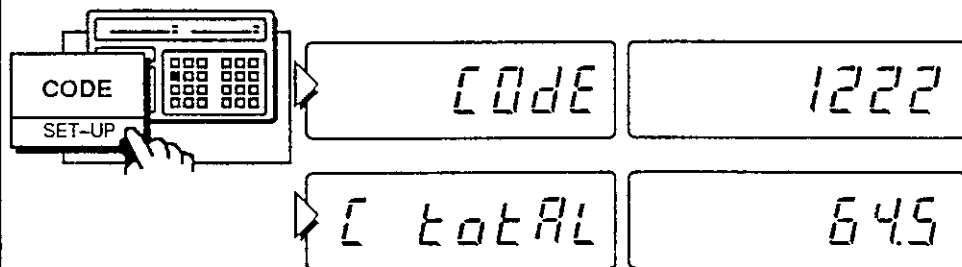

Display Example

- Press the **CODE** key.
- The code number you are presently in will appear on the right display for a few seconds, then:
- The CODE TOTAL will appear on the right display.

Step 3.

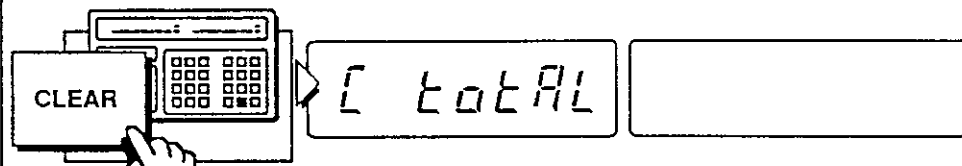

- Press the **CLEAR** key.
-  If you mistakenly press the **CLEAR** key and the display clears, press the **CLEAR** key again immediately and the amount will return.
- The CODE TOTAL will disappear.

Step 4.



Press the **ENTER** key to return to the weighing mode. 

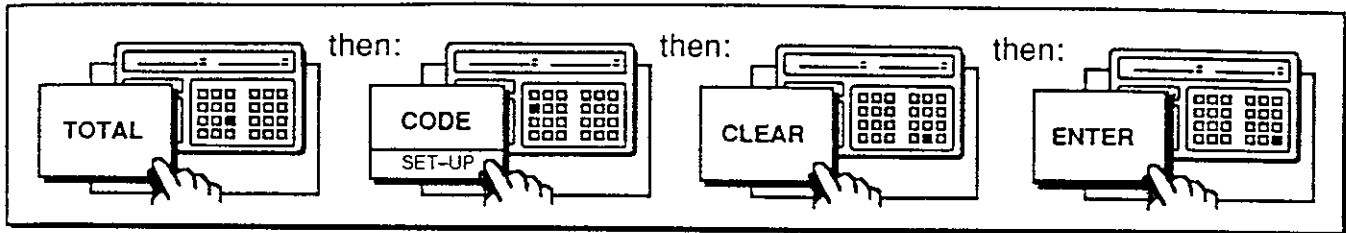



To Clear all of the Code Total's



This procedure clears all of the stored CODE TOTAL's at one time, there is no way to recover them. Use this feature carefully!

Step 1. Start with the display turned OFF.

Step 2. Press and hold the number  key, then press the  key - release the keys.

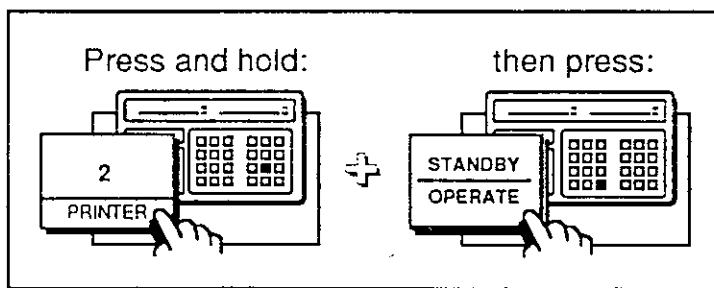

Display The displays come ON to normal weighing mode. All of the stored CODE TOTAL's will have been erased. 

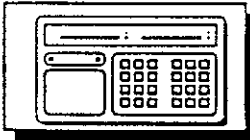

AD-4322AMKII Weighing Indicator

Print Out



Simple Printing

Step 1.

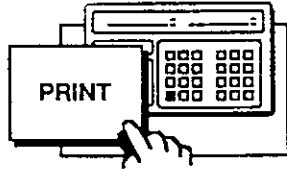

TARE	200.0 kg
NET	600.0 kg
GROSS	800.0 kg
16:55	WED 6/ 7/1989

Print Example

- Press the **PRINT** key.
- The weight data will be printed.
- The printout format is selectable via F-Function F-61 (p.144) as exemplified below:



Simple Printing Examples

ex: 1



- Print the weight display.

NET	600.0 kg
-----	----------

ex: 2



- Print TARE, NET and GROSS.

TARE	200.0 kg
NET	600.0 kg
GROSS	800.0 kg

ex: 3



- Print the weight display with the time/date (OP-09 digital clock installed):

NET	600.0 kg
16:54	WED 6/ 7/1989

ex: 4



- Print TARE, NET and GROSS with the time/date (OP-09 digital clock installed).

TARE	200.0 kg
NET	600.0 kg
GROSS	800.0 kg
16:55	WED 6/ 7/1989

ex: 5

F- 61 5

Print Gross, Tare, Net with the time/date (OP-09 digital clock installed).

ID#	185
TARE	200.0 kg
NET	600.0 kg
GROSS	800.0 kg

F61-2
ID 105

ex: 6 When F-61 is set to 2, 4, 5, 7, 9 pr 10

F- 61 2 or 4 or 5

I.D. function was used in the weighing event (example: I.D. 105).

ID#	185
TARE	200.0 kg
NET	600.0 kg
GROSS	800.0 kg

F61-2
ID 105

ex: 7

Code function was used in the weighing event (ex: Code 25).

CODE#	25
TARE	200.0 kg
NET	600.0 kg
GROSS	800.0 kg

F61-2
Code 25

ex: 8

The comparator function was used in the weighing event.

NET	Udr	200.0 kg
NET	Acc	500.0 kg
NET	Ovr	700.0 kg

F61-1



Printing Main Memory Total

When the M+ print mode (see page 85) is Off, the Main Memory Total can be printed using following procedure.

When the M+ print mode is On, the Main Memory Total as well as Code Total can be printed.

Step 1.



Display Example

- Press the **TOTAL** key.
- The main memory TOTAL will appear on the right display.

Step 2.

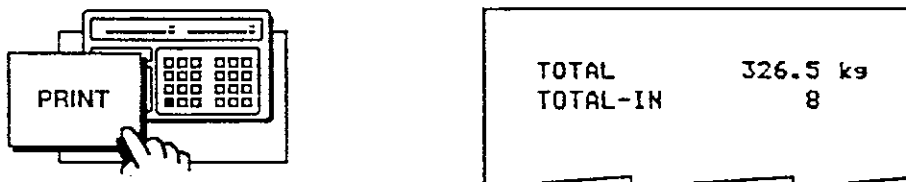

Print Example

- Press the **PRINT** key.
- The main memory TOTAL and the main memory TOTAL-IN (inputs, the number of times the **M+** (or **M-**) key was pressed to add/subtract to the main memory TOTAL) will be printed.

When printing is completed, the display is returned to the Normal Weighing Mode.

After printing, TOTAL can be cleared automatically with F-63.



To Print a Code Total

Prelim: You must have a code set active if you want to print its CODE TOTAL. If you are not in a code set already, do so now.

Step 1.

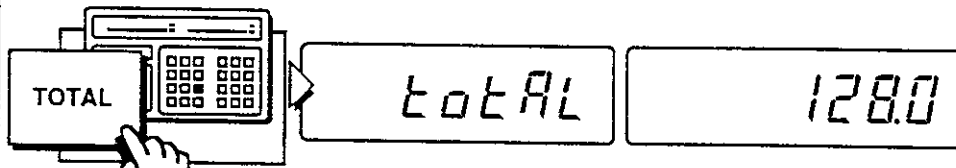

Display Example

- Press the **TOTAL** key.
- The main memory TOTAL will appear on the right display.

Step 2.

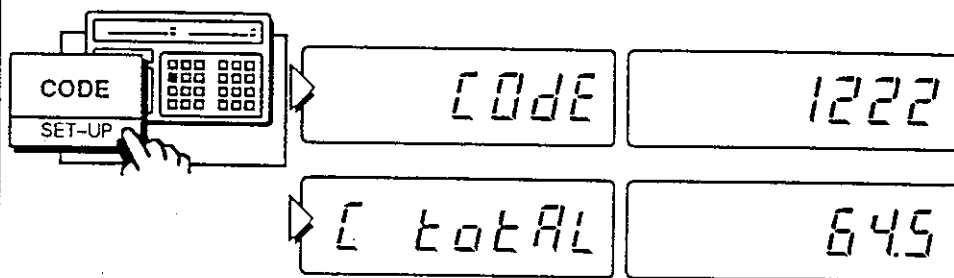

Display Example

- Press the **CODE** key.
- The code number you are presently in will appear on the right display for a few seconds, then:
- The CODE TOTAL will appear on the right display.

Step 3.

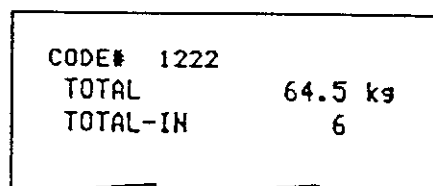
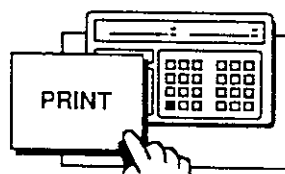

Print Example

- Press the **PRINT** key.
- First the Code number and its CODE TOTAL and the Code TOTAL-IN (inputs, the number of times the **M+** (or **M-**) key was pressed to add/subtract to the main memory TOTAL) will be printed.

When printing is completed, the display is returned to the Normal Weighing Mode.

After printing, TOTAL can be cleared automatically with F-63.



To Print all of the Code Total's

Step 1.

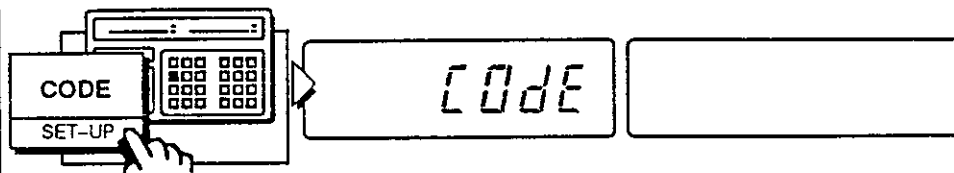

- Press the **CODE** key.
- "COdE" (Code) will be displayed.

Step 2.

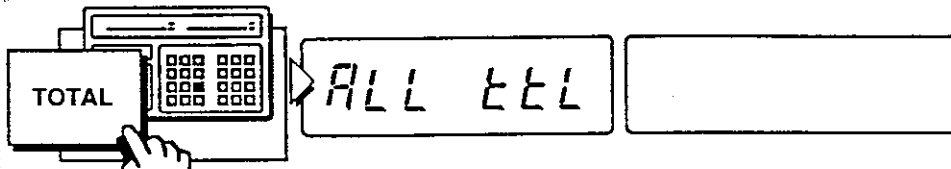

- Press the **TOTAL** key.
- "ALL tLl" (All CODE TOTALS) will be displayed.

Step 3.

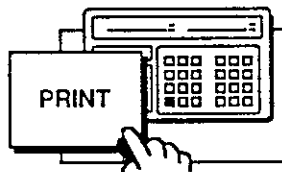

- Press the **PRINT** key.
- First the CODE TOTALS will be printed, then the main memory TOTAL will be printed. If the optional clock is installed, then the time and date will be printed.

CODE#	100	
TOTAL	1171.4	kg
TOTAL-IN	5	
CODE#	110	
TOTAL	801.4	kg
TOTAL-IN	7	
CODE#	120	
TOTAL	3082.9	kg
TOTAL-IN	3	
TOTAL	5055.7	kg
TOTAL-IN	15	
17:07	WED	6/ 7/1989

Print Example

The Code Total is printed from lowest code number. When data of Code Total and Code Total-In are zero, printing or non-printing can be selected with F-66.

When printing is completed, the display is returned to the Normal Weighing Mode.

After printing, TOTAL can be cleared automatically with F-63.



Auto Print



- Using the Auto Print mode, weighing event results are printed automatically.
- When the display exceeds zero band setting (F-15), and is stable. The data is printed once.

⚠ This feature will not work if F-Function F-6 (MOTION DETECTION CONDITION, see p. 137) is set at '0' or '10'.



To Set Auto Print Mode

Step 1.

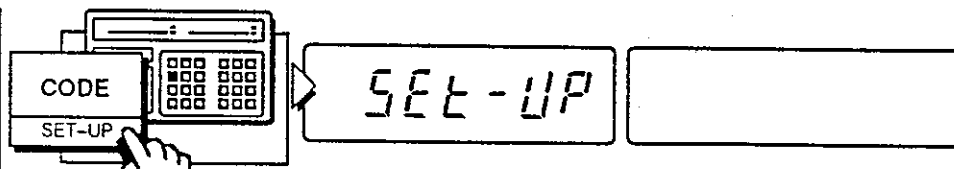

- From the weighing mode, press and hold the  key for five seconds until "SET-UP" appears.

Step 2.

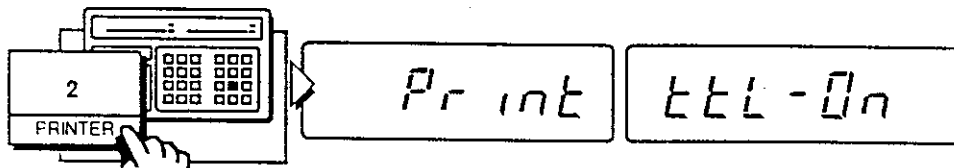

- Press the  key.
- Either "Print ttL-On" (Print TOTAL mode On) or "Print ttL-OFF" (Print TOTAL mode Off) will be displayed, depending the last setting.

Step 3.

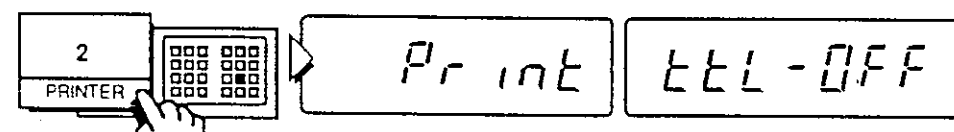

Correct Display

- ⚠ If "Print ttL-On" (Print TOTAL mode On) is displayed, press the  key to switch to "Print ttL-OFF" (Print TOTAL mode Off).

Step 4.

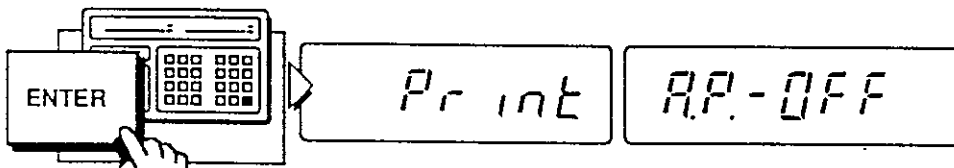

- Press the  key.
- Either "Print A.P.-OFF" (Auto Print Off) or "Print A.P.-On" (Auto Print On) will be displayed, depending the last setting.

Step 5.

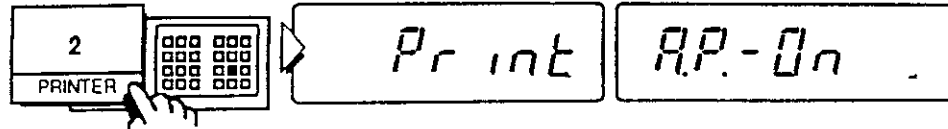

Correct
Display

- ▶ If "Print A.P.-OFF" (Auto Print Off) is displayed, press the  key to switch to "Print A.P.-On" (Auto Print On).

Step 6.

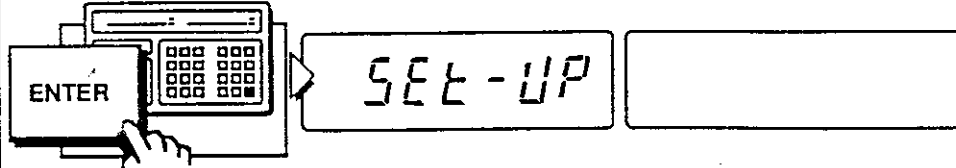

- ▶ When "Print A.P.-On" is displayed, press the  key.
- "SEt - UP" will be displayed.

Step 7.

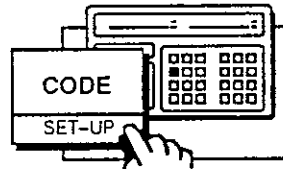

Press and hold the  key for five seconds until the display returns to the weighing mode.

- Weighing event results are now printed automatically when the display exceeds Zero band set with the function key F-15, and is stable. The data is printed once. 



The M+ Print Mode



When the **M+** (or **M-**) key is pressed:

- The displayed weight is printed (see page 87).
- The displayed weight will be added (or subtracted) to the main memory TOTAL and the TOTAL-IN (inputs, the number of times the **M+** {or **M-**} key was used to add/subtract to the main memory TOTAL) – also the CODE TOTAL, if a code set is active (see page 88 to printout main memory TOTAL).



To Set M+ Print Mode

Step 1.

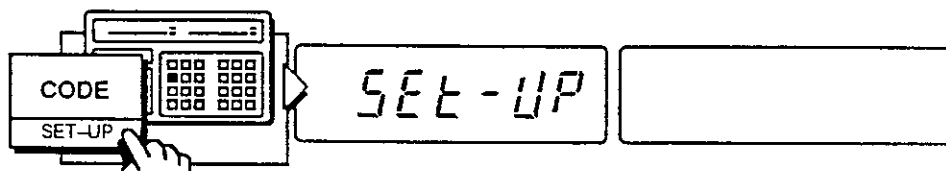

- From the weighing mode, press and hold the **CODE SET-UP** key for five seconds until "SET-UP" appears.

Step 2.

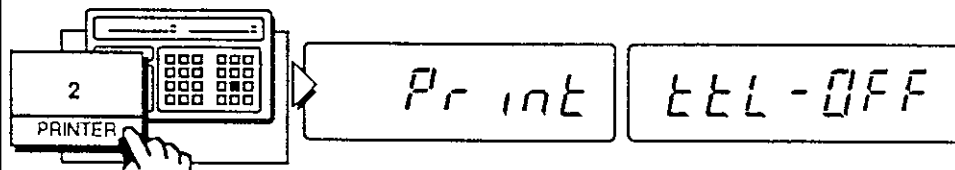

- Press the **2 PRINTER** key.
- Either "Print ttL-OFF" (Print TOTAL mode Off) or "Print ttL-On" (Print TOTAL mode On) will be displayed, depending the last setting.

Step 3.

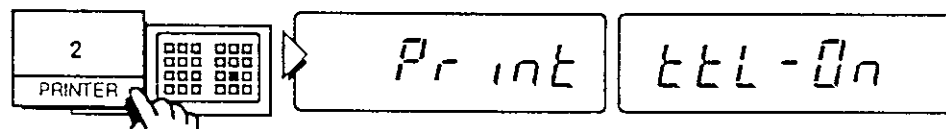

- !** If "Print ttL-OFF" (Print TOTAL mode Off) is displayed, press the **2 PRINTER** key to switch to "Print ttL-On" (Print TOTAL mode On).

Step 4.

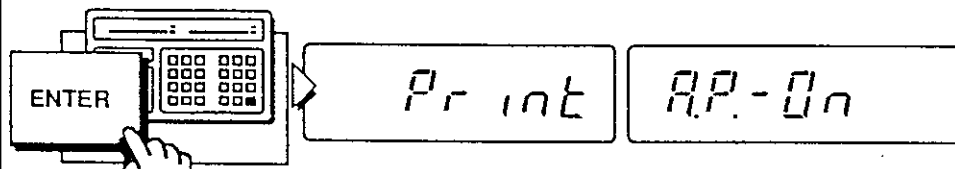

- Press the **ENTER** key.
- Either "Print A.P.-On" (Auto Print On) or "Print A.P.-OFF" (Auto Print Off) will be displayed, depending the last setting.

Step 5.

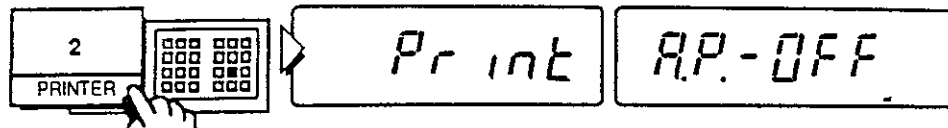

Correct
Display

⚠ If "Print A.P.-On" (Auto Print On) is displayed, press the  key to switch to "Print A.P.-OFF" (Auto Print Off).

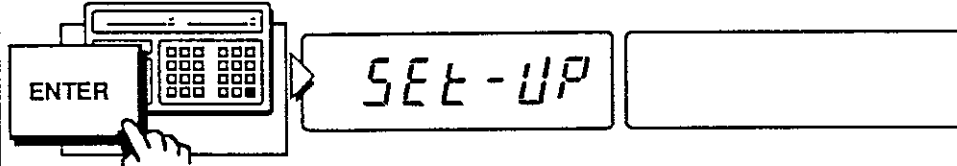

Step 6.

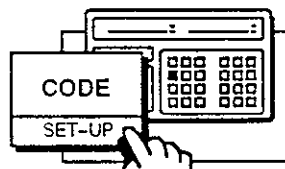

- When "Print A.P.-OFF" is displayed, press the  key.
- "SEt - UP" will be displayed.

Step 7.



Press and hold the  key for five seconds until the display returns to the weighing mode. 

Using the M+ Print Mode

Step 1.

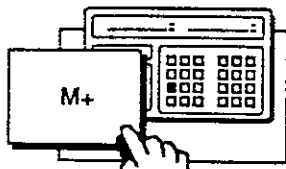

When no Code Set is active,
'CODE# CLEAR' is printed

CODE#	CLEAR
1	200.0 kg
2	200.1 kg
3	200.2 kg

Print
Example

- ▶ Press the **M+** (or **M-**) key when a weight is displayed.
- Each time the **M+** (or **M-**) key is pressed, the event number and weight is printed.

Step 2.

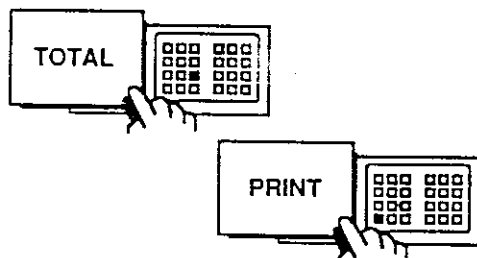

CODE#	CLEAR
1	200.0 kg
2	200.1 kg
3	200.2 kg
4	200.0 kg
M- → 3-	200.0 kg
4	200.0 kg
5	199.9 kg
6	200.0 kg
TOTAL 1200.2 kg	
TOTAL-IN 6	
17:22	WED 6/ 7/1989

Print
Example

- ▶ If you wish to print the Main Memory TOTAL, press then the **TOTAL** key, then the **PRINT** key.
- The Main Memory TOTAL, and TOTAL-IN (inputs) will be printed. If the optional clock is installed, then the time and date will be printed.

When code numbers are stored in the memory, the printer prints code Total first, then prints Main Memory Total.

The printing is executed from lowest code number.

When data of Code Total and Code Total-In are zero, printing or non-printing can be selected with F-66.

When printing is completed, the display is returned to the Normal Weighing Mode.

After printing, TOTAL can be cleared automatically with F-63.



Using the M+ Print Mode with Code

- ❑ When you change to a new Code set, the new code number will be printed.
- ❑ Each time the **M+** (or **M-**) key is pressed, the event number and weight is printed.
- ▶ When you wish to print the total, press then the **TOTAL** key, then the **PRINT** key. First the CODE TOTAL(s) will be printed, then the Main Memory TOTAL will be printed. If the optional clock is installed, then the time and date will be printed. **VI**

CODE#	100	
1		399.9 kg
2		400.0 kg
3		400.2 kg
CODE#	110	
4		200.0 kg
5		200.1 kg
6		200.2 kg
7		200.3 kg
8		199.9 kg
CODE#	100	
TOTAL		1200.1 kg
TOTAL-IN		3
CODE#	110	
TOTAL		1000.5 kg
TOTAL-IN		5
TOTAL		2200.6 kg
TOTAL-IN		8
17:28	WED	6/ 7/1989

Print
Example

When code numbers are stored in the memory, the printer prints Code Total first, then prints Main Memory Total.

The printing is executed from lowest code number.

When data of code Total and Code Total-In are zero, printing or non-printing can be selected with F-66.

When printing is completed, the display is returned to the Normal Weighing Mode.

After printing, TOTAL can be cleared automatically with F-63.



Auto M+ Print Mode



When a weight exceeds Zero Band set with the function key F15, and is stable, the weight will be added to the main memory total

The display must return to zero (less than 6 divisions) before another weight can be added and printed.

⚠ When using Auto M+ Print Mode and the code function (see page 54) you will be adding automatically to both the main memory total and the code total.

⚠ This feature will not work if F-Function F-6 (MOTION DETECTION CONDITION, see p. 137) is set at '0' or '10'.



To Set Auto M+ Print Mode

Step 1.

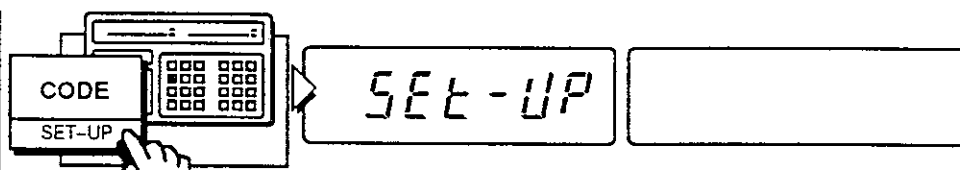

- ▶ From the weighing mode, press and hold the  key for five seconds until "SET-UP" appears.

Step 2.

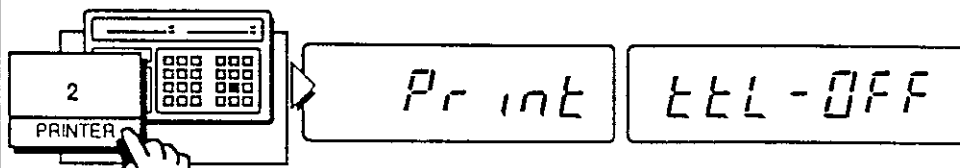

- ▶ Press the  key.
- Either "Print ttL-OFF" (Print TOTAL mode Off) or "Print ttL-On" (Print TOTAL mode On) will be displayed, depending the last setting.

Step 3.

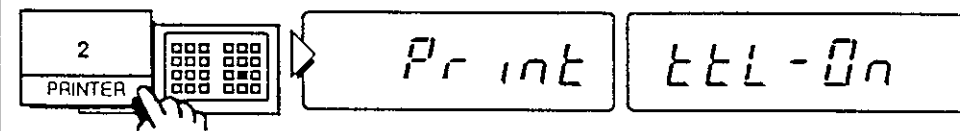

- ⚠ If "Print ttL-OFF" (Print TOTAL mode Off) is displayed, press the  key to switch to "Print ttL-On" (Print TOTAL mode On).

Step 4.

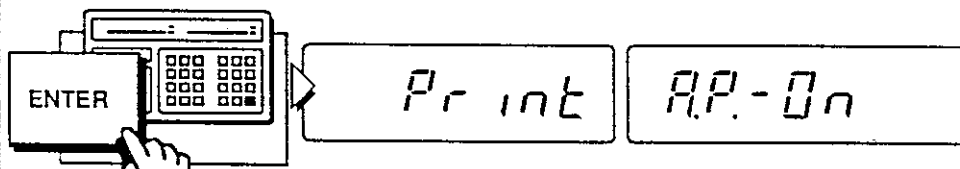

- ▶ Press the  key.
- Either "Print A.P.-On" (Auto Print On) or "Print A.P.-OFF" (Auto Print Off) will be displayed, depending the last setting.)

Step 5.

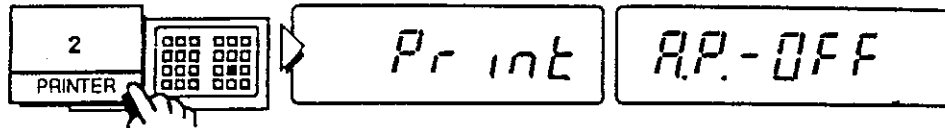

Correct Display

⚠ If "Print A.P.-On" (Auto Print On) is displayed, press the  key to switch to "Print A.P.-OFF" (Auto Print Off).

Step 6.

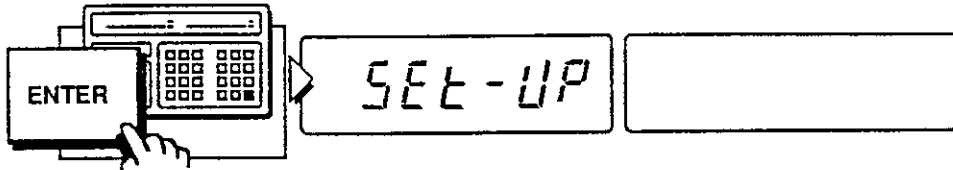

- When "Print A.P.-OFF" (Auto Print Off) is displayed, press the  key.
- "SET-UP" will be displayed.

Step 7.

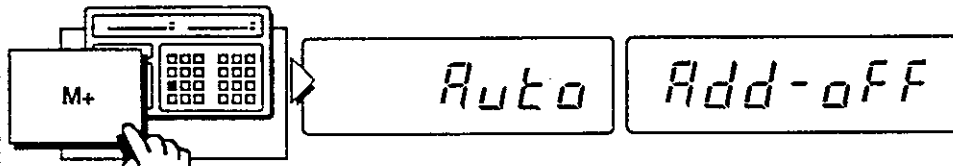

- Press the  key.
- Either "Auto Add-oFF" (Automatic Adding Off) or "Auto Add-on" (Automatic Adding On) will be displayed, depending on the last setting.

Step 8.

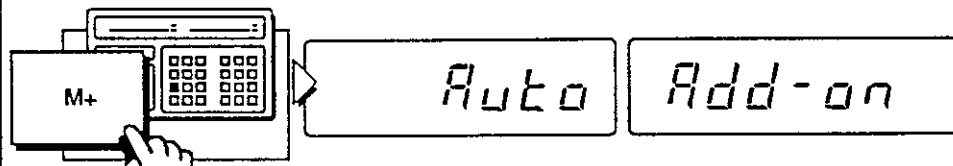

Correct Display

⚠ If "Auto Add-oFF" (Automatic Adding Off) is displayed, press the  key to switch to "Auto Add-on" (Automatic Adding On).

Step 9.

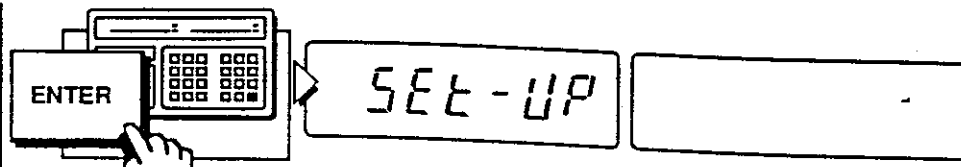

▶ When "Auto Add-on" (Automatic Adding On) is displayed, press the **ENTER** key.

Step 10.

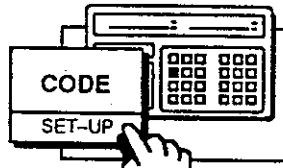

Press and hold the **CODE SET-UP** key for five seconds until the display returns to the weighing mode. **VI**



Using the Auto M+ Print Mode

Printout

- Each time you weigh, the event number and weight is printed.

When no Code Set is active, 'CODE# CLEAR' is printed

CODE#	CLEAR	
1		200.0 kg
2		200.1 kg
3		200.2 kg

Print Example

TOTAL Printout

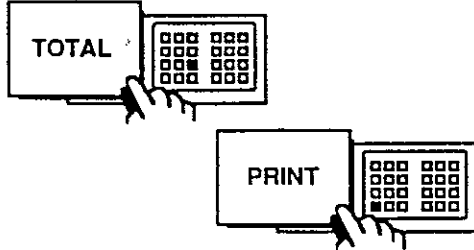

- ▶ If you wish to print the Main Memory TOTAL, press then the **TOTAL** key, then the **PRINT** key.
- The Main Memory TOTAL, and TOTAL-IN (inputs) will be printed. If the optional clock is installed, then the time and date will be printed.

CODE#	CLEAR	
1		200.0 kg
2		200.1 kg
3		200.2 kg
4		200.0 kg
5		199.9 kg
6		200.0 kg
TOTAL		1200.2 kg
TOTAL-IN		6
17:22	WED	6/ 7/1989

Print Example

When code numbers are stored in the memory, the printer prints Code Total first, then prints Main Memory Total.

The printing is executed from lowest code number.

When data of Code Total and Code Total-In are zero, printing or non-printing can be selected with F-66.

When printing is completed, the display is returned to the Normal Weighing Mode.

After printing, TOTAL can be cleared automatically with F-63.



Using the Auto M+ Print Mode with Code

- When you change to a new Code set, the new code number will be printed.
- Each time you weigh, the event number and weight is printed.
- When you wish to print the total, press then the **TOTAL** key, then the **PRINT** key. First the CODE TOTAL will be printed, then the Main Memory TOTAL will be printed. If the optional clock is installed, then the time and date will be printed. **W**

CODE#	180	
1		399.9 kg
2		400.0 kg
3		400.2 kg
CODE#	110	
4		200.0 kg
5		200.1 kg
6		200.2 kg
7		200.3 kg
8		199.9 kg
CODE#	180	
TOTAL		1200.1 kg
TOTAL-IN		3
CODE#	110	
TOTAL		1000.5 kg
TOTAL-IN		5
TOTAL		2200.6 kg
TOTAL-IN		8
17:28	WED	6/ 7/1989

Print
Example

When code numbers are stored in the memory, the printer prints Code Total first, then prints Main Memory Total.

The printing is executed from lowest code number.

When data of Code Total and Code Total-In are zero, printing or non-printing can be selected with F-66.

When printing is completed, the display is returned to the Normal Weighing Mode.

After printing, TOTAL can be cleared automatically with F-63.



Printing Items from the Memory



There are a number of items, settings, etc, which have been entered into the AD-4322AMKII's memory that can be printed.



I.D./TARE Settings Printout



The following procedure is to see the settings for each of the I.D./Tare numbers that you have entered into the AD-4322AMKII.

Step 1.

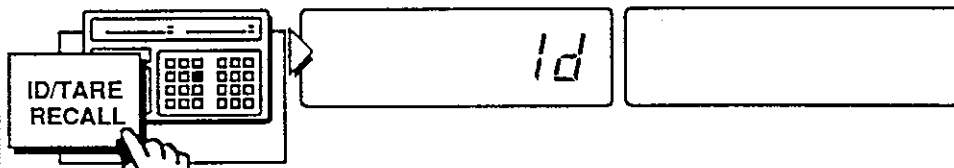

- ▶ Press the **ID/TARE RECALL** key.
- "Id" will be displayed (if an I.D. number has been previously entered, it will appear on the right display).

Step 2.

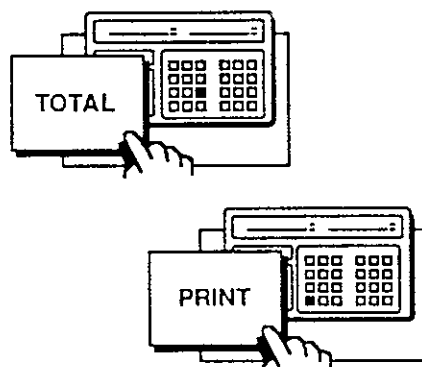

***** ID/TARE LIST *****			
ID#	10		
TARE		100.0	kg
ID#	15		
TARE		157.0	kg
ID#	20		
TARE		132.5	kg

Print Example

- ▶ Press then the **TOTAL** key, then the **PRINT** key.
- Each I.D. number will be printed with the Tare amount associated with it.

The printing is executed from lowest I.D. number.

When printing is completed, the display is returned to the Normal Weighing Mode.

Code Settings Printout



The following procedure prints out the settings for each of the code sets that have been entered into the AD-4322AMKII.

Step 1.

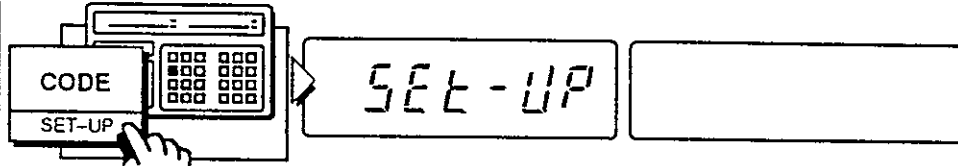

- ▶ From the weighing mode, press and hold the CODE SET-UP key for five seconds until "SET-UP" appears.

Step 2.

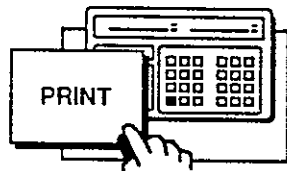

- ▶ Press the PRINT key.
- Each code number will be printed with the settings for that code. Also, the automatic settings will be printed.

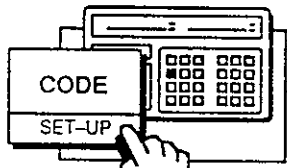

- ▶ Press and hold the CODE SET-UP key for five seconds to return to normal weighing when finished. V

```

**** CODE/MODE LIST ****
CODE#  100
TARE           25.0 kg
SP-UNDER      399.5 kg
SP-OVER       400.5 kg
TOTAL         1200.1 kg
TOTAL-IN              3
CODE#  110
TARE           100.0 kg
SP-UNDER      199.0 kg
SP-OVER       201.0 kg
TOTAL         1000.5 kg
TOTAL-IN              5

AUTO-ADD           OFF
COMPARATOR         ON
TOTAL-MODE         ON
AUTO-PRINT         OFF
15:54   THU  6/ 8/1989
    
```

Print Example

Printing the Time (with Option OP-09)



The time and date can be printed out at any time using the following procedure.

Press and hold the **ENTER** key.

Then press the **3** **CLOCK** key, release.

○ The printout will show the time and date.

F-Function Settings Printout

Step 1. Start with the display On.

Step 2.

▶ Open the panel cover on the front of the AD-4322AMKII by unscrewing the knobs' to expose the slide switches

Step 3.

▶ Slide the right slide-switch (F-Function) ON ⇒.

○ "F - " will be shown on the left display.

Step 4.

▶ Press the **PRINT** key.

○ All function settings will be printed.

Step 5.

▶ When printout is finished, slide the F-Function slide switch = OFF. Reinstall the panel cover.

Printout Examples

Main Memory TOTAL

TOTAL PRINT • ENTER ENTER

TOTAL 326.5 kg
TOTAL-IN 8

see page 37

CODE TOTAL

TOTAL CODE PRINT
• ENTER ENTER

CODE# 1222
TOTAL 64.5 kg
TOTAL-IN 6

see page 81

M+ Print Mode

see pages 87, 85

Auto M+ Print Mode

see pages 92, 89

CODE# CLEAR
1 200.0 kg
2 200.1 kg
3 200.2 kg

These examples are not using CODE ↓

All ID/TARE Settings

ID/TARE RECALL TOTAL PRINT • CLEAR

***** ID/TARE LIST *****

ID# 10
TARE 100.0 kg
ID# 15
TARE 157.0 kg
ID# 20
TARE 132.5 kg

see page 94

All CODE TOTALS

CODE TOTAL PRINT • CLEAR

CODE# 100
TOTAL 1171.4 kg
TOTAL-IN 5
CODE# 110
TOTAL 801.4 kg
TOTAL-IN 7
CODE# 120
TOTAL 3082.9 kg
TOTAL-IN 3

TOTAL 5055.7 kg
TOTAL-IN 15
17:07 WED 6/ 7/1989

see page 82

CODE# CLEAR
1 200.0 kg
2 200.1 kg
3 200.2 kg
4 200.0 kg
5 199.9 kg
6 200.0 kg

TOTAL 1200.2 kg
TOTAL-IN 6

17:22 WED 6/ 7/1989

All CODE Settings

CODE SET-UP PRINT • CODE SET-UP

**** CODE/MODE LIST ****

CODE# 100
TARE 25.0 kg
SP-UNDER 399.5 kg
SP-OVER 400.5 kg
TOTAL 1200.1 kg
TOTAL-IN 3
CODE# 110
TARE 100.0 kg
SP-UNDER 199.0 kg
SP-OVER 201.0 kg
TOTAL 1000.5 kg
TOTAL-IN 5

AUTO-ADD OFF
COMPARATOR ON
TOTAL-MODE ON
AUTO-PRINT OFF
15:54 THU 6/ 8/1989

see page 95

Printing the Time

ENTER + CLOCK

Digital Clock Option OP-09 Required

16:40 THU 6/ 8/1989

24 hr. 12 hr.

4:40 PM THU 6/ 8/1989

see page 96

TOTAL PRINT • ENTER ENTER

CODE# 100
1 399.9 kg
2 400.0 kg
3 400.2 kg
CODE# 110
4 200.0 kg
5 200.1 kg
6 200.2 kg
7 200.3 kg
8 199.9 kg

CODE# 100
TOTAL 1200.1 kg
TOTAL-IN 3

CODE# 110
TOTAL 1000.5 kg
TOTAL-IN 5

TOTAL 2200.6 kg
TOTAL-IN 8

17:28 WED 6/ 7/1989

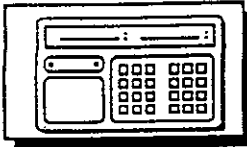

AD-4322AMKII Weighing Indicator

Truck Scale Mode



Truck scale Mode

The Truck scale mode, set by F-9, for a simple truck scale can be configured using the AD-4322AMKII and a built-in or external printer. The truck scale mode can be used for weighing in only, or weighing in and weighing out.

Totalizing by Code can be done when Code Numbers are used.

Mode Setting		
F - 9	1	Normal Mode (setting upon shipment)
	2	Truck Scale Mode 1
	3	Truck Scale Mode 2

Truck Scale Mode

There are two modes that can be accessed for using the AD-4322AMKII as a truck scale indicator. After printing, the Tare display is Cleared and all values are remembered until a new tare is entered by any method including I.D. Number or Code Number.

In the truck Scale Mode1, if additions to or subtractions from memory are required, use the M+ or M- keys. In the truck Scale Mode2, if you are printing, the net weight will be automatically added to memory. You can use M+ and M- keys in this mode. With both of these modes, you can use Code M+ Memory.



Truck Scale

Truck Scale Mode

A truck scale can be configured by combining the AD-4322AMKII with:

- 1: Built-in Printer, Op-08
- 2: External Printer such as the AD-8118A, AD-8115C or AD-8117A
- 3: Combination of the built-in printer and an external printer.

When using the AD-4322AMKII as a Truck Scale Indicator, set F-9 to Truck Scale Modes 1 or 2. Set F-61 to 5 or 10 for the correct number of characters per line.

Registering the Tare Weight for One-time Weighing

A: When the unladen (tare) weight is already known:

- Step 1: Enter the unladen weight with the numerical keys.
- Step 2: Press the ENTER key.
- Step 3: Press the I.D./TARE STORE key.
- Step 4: Enter the I.D. numbers using the numerical keys.
- Step 5: Press the I.D./TARE STORE key.

B. When the unladen (tare) weight is unknown.

- Step 1: Place the empty truck on the scale.
- Step 2: Press the TARE key.
- Step 3: Press the I.D./TARE STORE key.
- Step 4: Enter the I.D. numbers using the numerical keys.
- Step 5: Press the I.D./TARE STORE key.

Note: If the I.D. numbers blink when it is entered, it indicates the I.D. numbers already has a tare value stored in it. If you wish to enter a new tare to the I.D. number, simply press the I.D./TARE STORE key a second time.

If you wish to leave the previously entered value intact, press the Clear key, and then re-enter an unused I.D. number.

Auto Main Memory Total Add Mode (page 39), must be inactive when registering I.D. numbers, otherwise all tares will be added to Main Memory Totals.

Operational Procedure for One-time Weighing

Step 1	When the truck is placed on the scale, a weighed value appears on the left display.
Step 2.	Enter the truck I.D. number by pressing the I.D./TARE RECALL key, entering the I.D. numbers using the numerical keys and then pressing the ENTER key. The weight of the truck will be subtracted from the weigh in Tare Memory and the difference will appear in the left display as a negative number.
Step 3.	The net weight will be displayed on the left and tare weight on the right. At this time, the weight values should be printed. Upon completion of printing, the gross (total) weight will show on the left display and the unladen (tare) weight is cleared from the right display, but will be retained in memory. Remove the truck form the scale

Operational Procedure for Two-time Weighing

1st Weighing

Step 1	When the truck is placed on the scale, a weighed value appears on the left display.
Step 2.	When the weight has stabilized- Press the TARE key. Press the I.D./TARE RECALLkey. Enter the I.D. number using the numerical keys. Press the ENTER Key.
Step 3.	Remove the truck from the scale.

2nd Weighing

Step 1	When the truck is placed on the scale, a weighed value appears on the left display.
Step 2.	Re-call the weight stored in the 1st weighing by- Pressing the I.D./TARE RECALL key Entering the I.D. numbers using the numerical keys Pressing the ENTER key. The left display will show the difference between the 2nd weight and the 1st weight (2nd minus the 1st) and the right display will show the 1st weight value.
Step 3.	Press the PRINT key to print the weighing result. Upon completion of printing, the total weight is displayed and the 1st weighed value stored in the memory is cleared.
Step 4.	Remove the truck from the scale.

Procedure when 1st weighing is with truck loaded

Step 1	Place the loaded truck on the scale for the 1st weighing. Press the TARE key. Enter an I.D. number if required.
Step 2.	Place the empty truck on the scale for the 1nd weighing. Recall the 1st weight from Tare Memory. The weight of the truck will be subtracted from the weighth in Tare Memory and the difference will appear in the left display as a negative number.
Step 3.	Press the PRINT key. The 1st weight will be printed as Gross, the 2nd weight (the truck weight) will be printed as Tare with the difference printed as Net.

To Clear Zero and Tare

Step 1 Start with the display turned Off.

Step 2. Press and hold the **TARE** key, then press the **STANDBY OPERATE** key - release the keys.

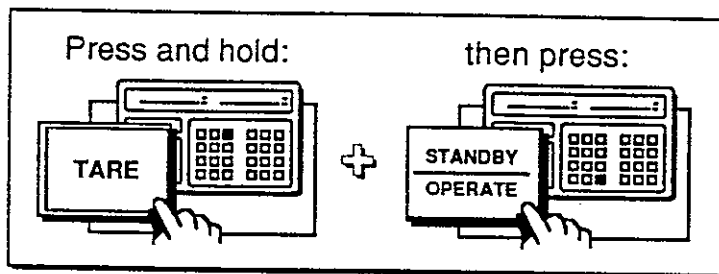

Display The displays come On in the normal weighing mode. Zero and Tare value will have been erased.

To Clear All of the Stored ID/TARE'S



This procedure clears all of the stored ID/Tare's at one time, there is no way to recover them. Use this feature carefully!

Step 1. Start with the display turned Off.

Step 2. Press and hold the **1 SETPOINT** key, then press the **STANDBY OPERATE** key - release the keys.

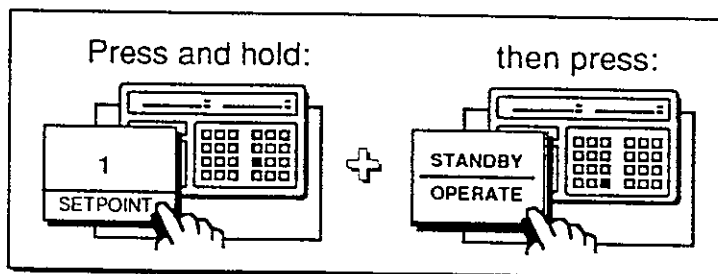

Display The displays come On in the normal weighing mode. All of the stored ID/Tare's will have been erased. 

To Clear all of the CODE TOTAL'S



This procedure clears all of the stored CODE TOTAL's at one time, there is no way to recover them. Use this feature carefully!

Step 1. Start with the display turned Off.

Step 2. Press and hold the  key, then press the  key - release the keys.

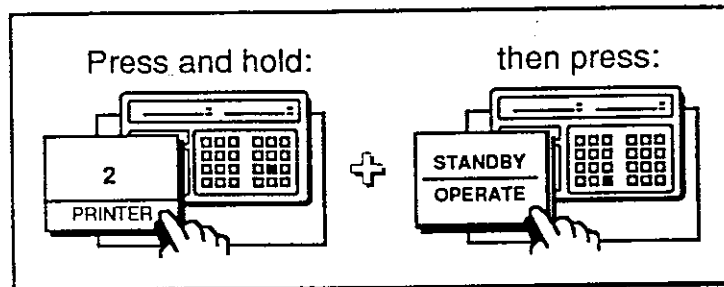



Display The displays come On in the normal weighing mode. All of the stored CODE TOTAL's will have been erased. 

Backup Data Initialization



Zero, Tare, Setpoint, Main Memory Total and Code Number are cleared, and Auto Print Mode, Auto M+ Mode, M+ Print Mode and Comparator Function are Off.

Step 1. Disconnect the power cord from AC power.

Step 2. Press and hold the  and  keys simultaneously, then connect the powercord to AC power.



○ When the message "init dAtA" (initialize data) is displayed, release the keys. The AD-4322AMKII returns to the Standby Mode.. 

ID/TARE Data Initialization



All ID/TARE data stored in the memory will be cleared. Apply the same procedure in Section 2.

Step 1 | Disconnect the power cord from AC power.

Step 2 | Press and hold the **1** and **CLEAR** keys simultaneously, then connect the powercord to AC power.



- When the message "init Id" (Initialize ID) is displayed, release the keys. The AD-4322AMKII returns to the Standby Mode.. **V**

Clearing all Code Memory Set



Code Number, Tare, Low Limit, High Limit, Code Total and Code Total-In are cleared..

Step 1 | Disconnect the power cord from AC power.

Step 2 | Press and hold the **2** and **CLEAR** keys simultaneously, then connect the powercord to AC power.



- When the message "init Code" (Initialize Code) is displayed, release the keys. The AD-4322AMKII returns to the Standby Mode.. **V**



Clearing all Backup Data, ID/TARE Data and Code Memory Set



All ID/TARE data stored in the memory will be cleared. Apply the same procedure in Section 2.

Step 1 | Disconnect the power cord from AC power.

Step 2 | Press and hold the **3** and **CLEAR** keys simultaneously, then connect the powercord to AC power.

init Id Code

- When the message "init Id Code" (Initialize Id Code) is displayed, release the keys. The AD-4322AMKII returns to the Standby Mode.. **VI**



Calibration Data Initialization



The Minimum Division, Capacity, Zero Calibration Span Calibration Gravity Compensation and Digital linearzation are initializad (at shipment condition).

Step 1 | Disconnect the power cord from AC power.

Step 2 | Press and hold the **4** and **CLEAR** keys simultaneously, then connect the powercord to AC power.

init CAL .

- When the message "init CAL" (Initialize Calibration) is displayed, release the keys. The AD-4322AMKII returns to the Standby Mode.. **VI**



F-Function Data Initialization



All F-Function are initialized (at shipment condition).

Step 1 | Disconnect the power cord from AC power .

Step 2 | Press and hold the **[5]** and **[CLEAR]** keys simultaneously, then connect the powercord to AC power.

init Func .

- When the message "init Func" (Initialize Function) is displayed, release the keys. The AD-4322AMKII returns to the Standby Mode.. **[V]**



Calibration Data and F-Function Data Initialization



This function combines Section 8 and 9.

Step 1 | Disconnect the power cord from AC power.

Step 2 | Press and hold the **[6]** and **[CLEAR]** keys simultaneously, then connect the powercord to AC power.

init CAL Func

- When the message "init CAL Func" (Initialize Calibration, Function) is displayed, release the keys. The AD-4322AMKII returns to the Standby Mode.. **[V]**

All Data Clear and Initialization



This function combines Section 4, 5, 6, 8 and 9.

Step 1 | Disconnect the power cord from AC power.

Step 2 | Press and hold the **7** and **CLEAR** keys simultaneously, then connect the power cord to AC power. (Or press and hold the **STANDBY** and **CLEAR** keys simultaneously, then connect the power cord to AC power.)

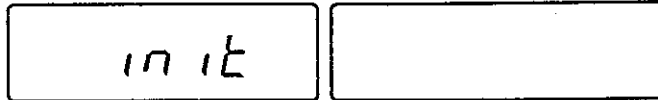

- When the message "init" (Initialize) is displayed, release the keys. The AD-4322AMKII returns to in the Standby Mode.. 

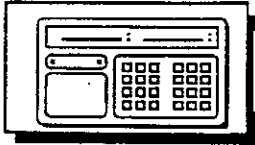

AD-4322AMKII Weighing Indicator

Calibration



About Calibration Terms



The AD-4322AMKII can print the weighed results by connecting optional built-in printer or external printer.

The external printers, AD-8118A (Dumb Print Mode), AD-8121 (Dumb Print Mode), AD-4348-2 (Ticket Printer), AD-8115C (Ticket Printer) are available. When connecting these printers, use the current loop or the RS-232C. The RS-232C interface is also usable for conventional printers.

To set the printing format, use F-61 and settings accordingly.

To connect an external printer, use F-21 or F-41 and settings according to the interface used.

The section FULL CALIBRATION PROCEDURE on the following pages contains the procedure to input the following information needed to make the AD-4322AMKII function as a Weighing Indicator. Below are some explanations for the major items and shortcuts for individual changes.

Minimum Division

The Display Resolution depends on, and is limited by, the Minimum Division. Display Resolution is Minimum Division divided by the Maximum Capacity. The Minimum Division's are the blocks in which the display will be able to show change in weight. If you set the AD-4322AMarkII for 1 internal minimum division, then the display will be able to move by one, ex: 101,102,103.... If you set it for 2 minimum divisions, then the smallest the display will be able to move is by two's, ex: 100,102,104.... And so forth. You are limited to 1,2,5,10,20, or 50 internal divisions - this is in turn limited by the Max. Capacity of your weighing device.

Maximum Capacity

The Maximum Capacity is the full weight that you want your weighing device to handle. This could be the rated capacity of the Load Cells, or some other limit you wish to set. Maximum Capacity also has a relationship to the Display Resolution. Resolution is Minimum Division divided by the Maximum Capacity.

Zero Calibration

The ZERO Calibration is simply: recalibrating the AD-4322AMKII, to the weighing device, when it has no weight acting on it ("0"). This gives the AD-4322AMKII a base reference point, "zero", to compare with when weight is added. It is possible that temperature changes, wear-and-tear of the Weighing Device, and other influences, may cause the "zero" point to drift - needing recalibration. You may want to do ZERO Calibration on a regular schedule, as weighing conditions demand.

Span Calibration

SPAN CALIBRATION is simply: recalibrating the AD-4322AMKII to the weighing device, at full capacity. With ZERO Calibration, you set an empty Weighing Device as your "zero" point. With SPAN Calibration, you set the end point of your Weighing Device's ability to weigh - its Max. Capacity. This gives the AD-4322AMKII two extreme points where it knows the correct weight. Now it can accurately calculate what the weights are in between. While the most accurate SPAN Calibration is with Max. Capacity as your SPAN weight - this may not always be possible. In those cases, use the weight closest to Max. Capacity as practical. • The closer to Max. Capacity the SPAN weight is - the more highly accurate the reading is (especially at the higher end.)



If You Want To Perform:

The steps below appear in the Full Calibration Procedure section on page 115.

ZERO Calibration ONLY:

If you only want to perform the ZERO calibration procedure, enter no changes - after Step 9, go to Step 13.

To Change Minimum Division ONLY:

If you only want to change the Minimum Division - after Step 5, go to Step 13.

To Change Maximum Capacity ONLY:

If you only want to change the Maximum Capacity - after Step 7, go to Step 13.

Any Mix of Changes:

If you only want to make some other mix of changes or calibrations, please just go through the procedure from the beginning and make your choices as you move through the procedure.



Calibration Flowchart

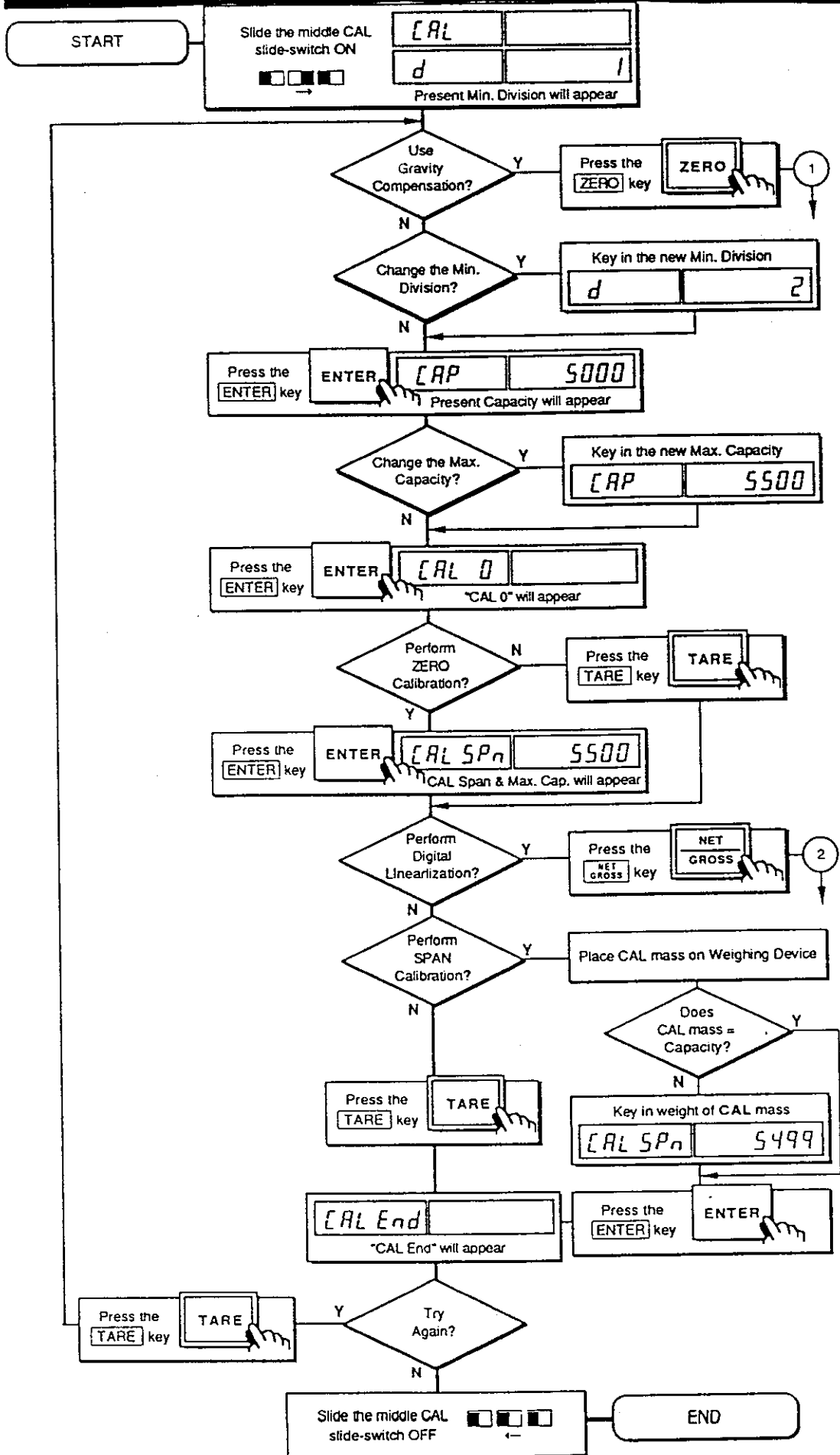

Gravity Compensation Flowchart

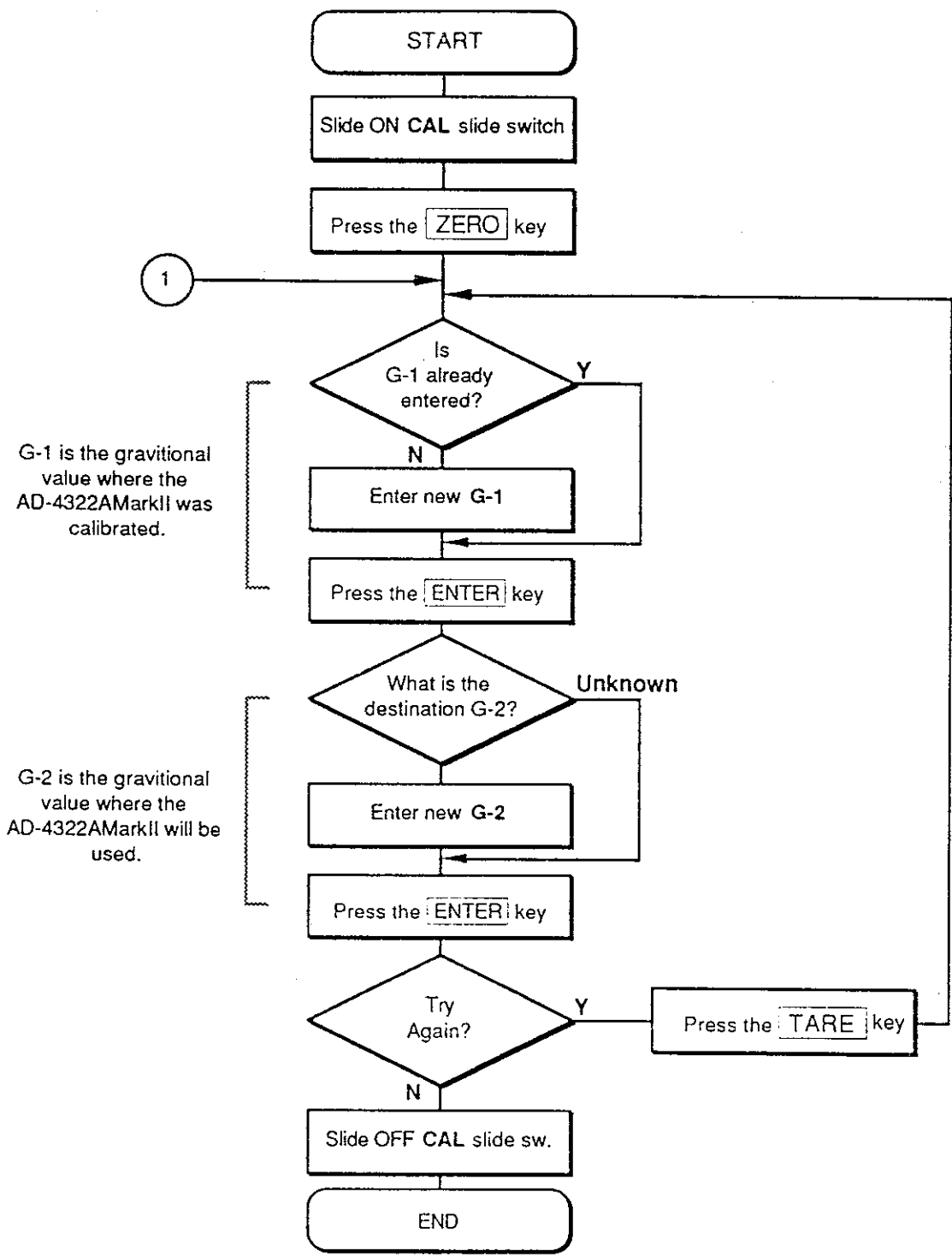



Digital Linearization Flowchart

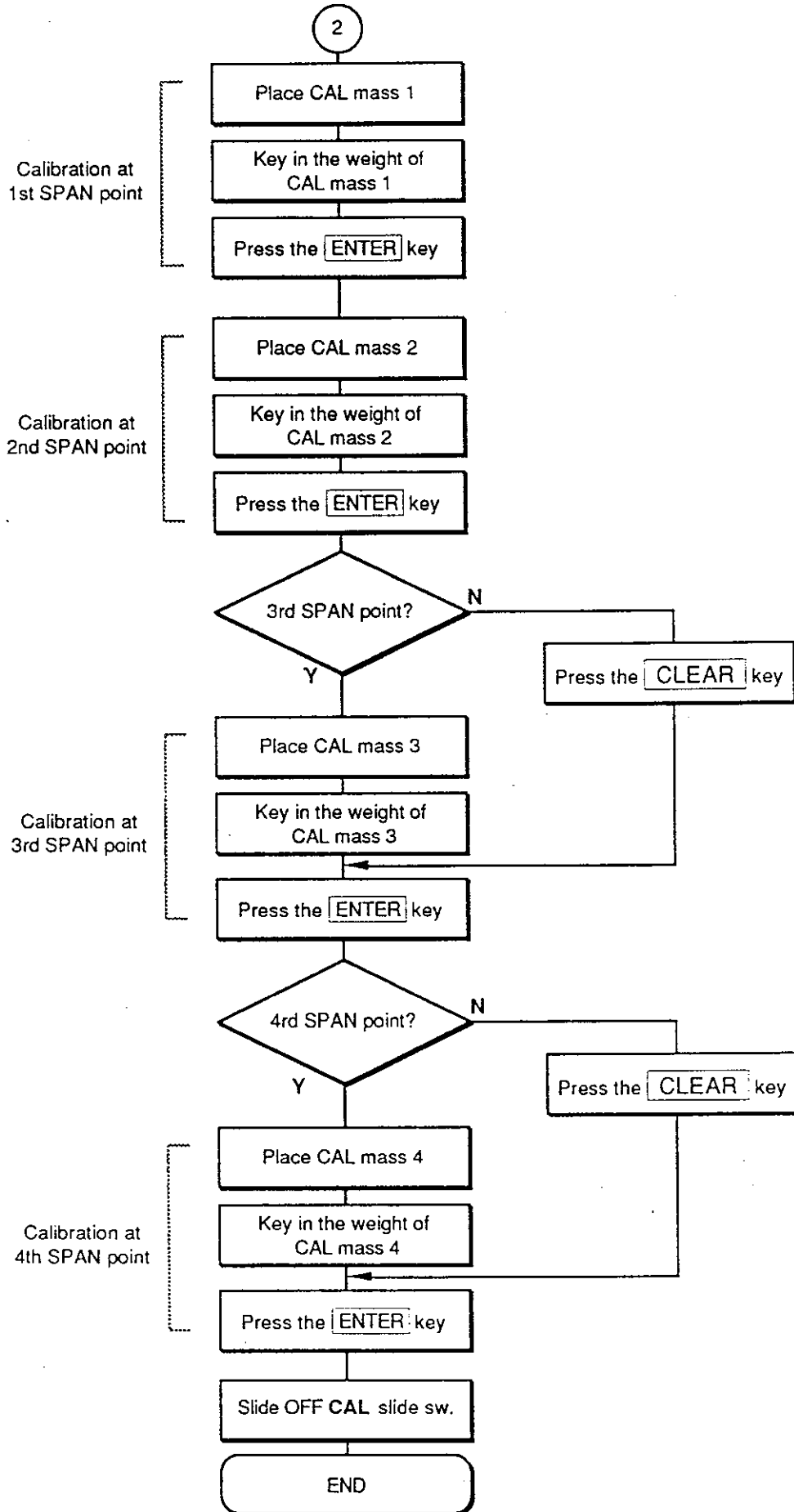



Full Calibration Procedure

※ Calibration and Changing Division or Capacity ※



- Your AD-4322AMKII should be calibrated when:
 - it is first installed, or if any part of the weighing system is changed.
 - if any drift is noted.

⚠ The AD-4322AMKII must be warmed up (plugged in) for at least 30 minutes before starting calibration.

⚠ During calibration, the weighing system must be kept stable for accurate adjustment.



If the Hertz selection is changed (F-8, see "F" FUNCTIONS AND THEIR SETTINGS section) after calibration - the Span calibration will no longer be correct.



The unit is convertible even if calibration is made in pound or kilogram. The Minimum Division on each unit is shown in Table below.

Calibration in Pound		Calibration in Kirogram	
Min.Div. (lb)	Min.Div. (kg)	Min.Div. (kg)	Min.Div. (lb)
1	0.5	1	2
2	1	2	5
5	2	5	10
10	5	10	20
20	10	20	50
50	20	50	-

Note: If Minimum Division is 50, the unit cannot be converted when calibrating in kilogram.

Note: The display examples shown in this procedure are the initial ones.

■ Minimum Division:

Step 1.

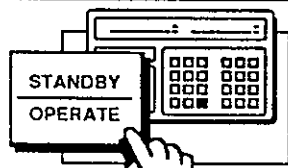

Press the **STANDBY OPERATE** key to turn the display On (if needed), and have nothing acting on the weighing device.

Step 2.



Open the panel cover on the front of the AD-4322AMKII unit by unscrewing the knobs - to expose the slide-switches.

Step 3.  Slide the middle CAL slide-switch ON⇒.

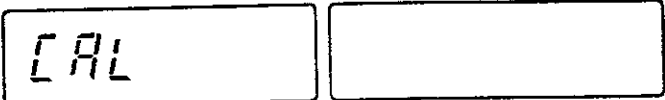
Display  "CAL" will appear briefly followed by:

 "XX" here is any previously entered minimum division.

Step 4. A) If you do not want to change the Min. Division, go to Step 5.
 B) If you wish to change the minimum divisions - please use the key pad now to display the new division.

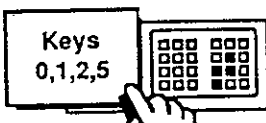

○ You are limited to one of the following internal Minimum Divisions: 1, 2, 5, 10, 20, or 50.

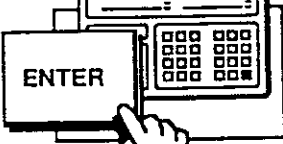
Step 5.  A) If there is no change, or B) When the correct new setting is displayed, press the **ENTER** key.

Display  "." will appear briefly, followed by:

■ Maximum Capacity:

 "XXXX" here is any previously entered maximum capacity.

Step 6. A) If you don't want to change the Max. Capacity, go to Step 7.
 B) If you wish to change the maximum capacity - please use the key pad now to display the new Max. Capacity.

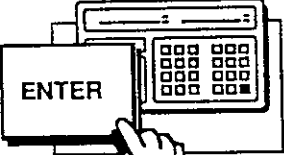

Step 7.  A) If there is no change, or B) When the correct new setting is displayed, press the **ENTER** key.

Display  "." will appear briefly, followed by:

■ ZERO Calibration:



"CAL 0" for ZERO CALIBRATION will be displayed.

Note: If ZERO Calibration is not needed, press the **TARE** key and go to SPAN Calibration.



Step 8. **MD** Wait until the "MD" (motion detection) indicator disappears.

Step 9. Press the **ENTER** key.

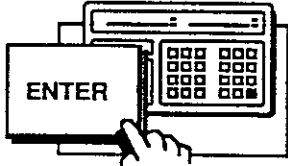

Display "....." will appear briefly, followed by:

■ SPAN Calibration:

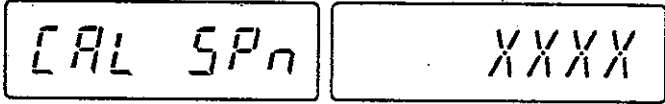

"XXXX" here is any previously entered Maximum Capacity.

Note: If SPAN Calibration is not needed, press the **TARE** key and go to Step 13.



- Step 10.
- If your calibration mass is the same as the Maximum Capacity, place the calibration mass on the weighing device - continue to Step 11.
 - If you are not using Max. Capacity as your SPAN weight, or the exact weight of the Cal. Mass is known - please enter in the weight of the calibration mass by using the key pad.
 - Place the calibration mass on the weighing device.

Step 11. **MD** Wait until the "MD" (motion detection) indicator disappears.

Step 12. Press the **ENTER** key.

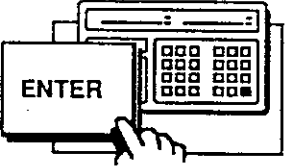

Display "....." will appear briefly, followed by:



Note: You may now remove the calibration mass from the weighing device.

Step 13.  Slide the middle CAL slide-switch OFF ←, replace the panel cover.

■ Setting the Decimal Place:

To set the decimal place - please follow the example given in the CHANGING THE F-FUNCTIONS procedure (page 134) in the F-FUNCTION section (The example given is how to set the decimal place).

 **Calibration Procedural Notes**

Note 1: When you slide Off the CAL switch (Step 13) the new values are entered into EEPROM.

Note 2: If the **CLEAR** key is held down while sliding Off the CAL switch (Step 13), then:

- a) The new values are *not* entered into EEPROM;
- b) "CANCEL" is displayed;
- c) The AD-4322AMarkII returns to weighing mode.



Note 3: If the **TARE** key is pressed while "CAL End" is displayed, then the procedure starts again at Step 4.

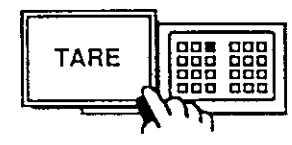



Calibration Errors

DISPLAY

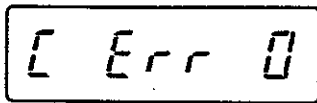

"C Err 0" will be displayed if the Min. Division set is not one of the ones available (1,2,5,10,20,50).

DISPLAY

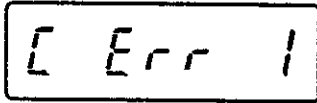

"C Err 1" will be displayed if the resolution exceeds 20,000 Divisions.

DISPLAY

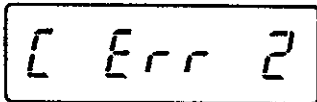

"C Err 2" will be displayed if Load Cell output is too large at ZERO Calibration.

In this case add an additional resistor between EXC+ and SIG-.

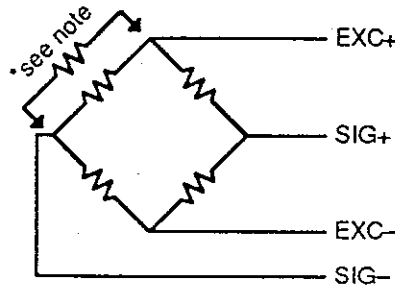

DISPLAY

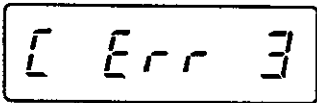

"C Err 3" is displayed if Load Cell output is too small (neg. offset) at ZERO Calibration.

In this case add an additional resistor between EXC+ and SIG+.

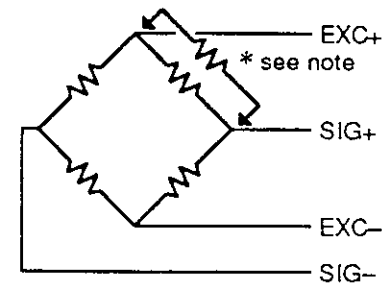

*Note:

The resistor should have as a high resistance as possible (50kΩ to 500kΩ) and should be of the highest quality, having the lowest temperature coefficient.

DISPLAY

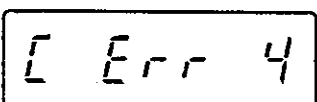

"C Err 4" will be displayed a Calibration Mass over Max. Capacity has been mistakenly entered.

DISPLAY

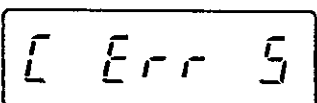

"C Err 5" will be displayed if the Calibration Mass has mistakenly entered as "0", or if it's smaller than the Min. Division.

DISPLAY

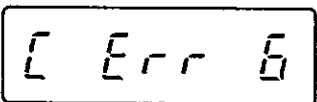

"C Err 6" will be displayed if the Load Cell output is too low.

DISPLAY

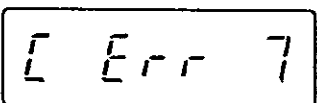

"C Err 7" will be displayed if the Load Cell signal pins are reversed, or incorrectly wired.

DISPLAY

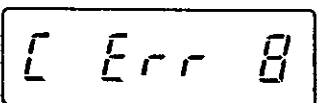

"C Err 8" will be displayed if the Load Cell output is too high.



Digital Linearization



If you have completed ZERO Calibration and SPAN Calibration, and there is still some linearity deviation - you may also want to add a second, third, or fourth SPAN point (preferably equal distant between ZERO and SPAN). This example will contain the following values:

- Minimum Division is set at 1
- Maximum Capacity is 20,000kg
- linear deviation of 2 divisions at 10,000kg



⚠ Make sure that you clear any SPAN value that is no longer going to be used! Be sure to remember this the next time you calibrate!

⚠ If the Hertz selection is changed (F-8, see "F" FUNCTIONS AND THEIR SETTINGS section) after calibration - the Span calibration will be off.



☑ *Remember:* In this procedure, the lightest weight must be entered as "Span 1" and the rest must also go in order from lightest to heaviest weights.

Step 1.

Follow the FULL CALIBRATION PROCEDURE through Step 9.

Step 2.

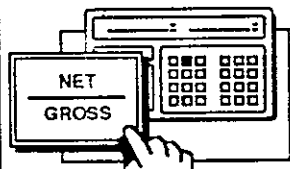

SPn 1

20000

Display Example

☑ After pressing the **ENTER** key in Step 9., press the **NET GROSS** key.

○ "SPn 1" (SPAN 1) will be displayed on the left display and the Maximum Capacity will be displayed on the right (in this example: 20,000kg).

Step 3.

Place a 10,000kg calibration mass on the weighing device.

⚠ *Remember that the lightest weight must be entered as "Span 1".*

Step 4.

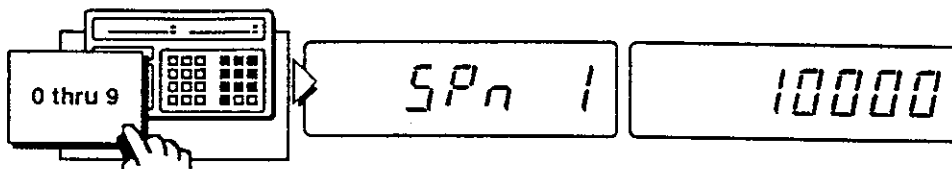

- ▶ Use the key pad to enter in the number 10,000 (for the 10,000kg calibration mass).

Step 5.

Wait for the Motion Detection (▼MD) annunciator to go OFF.

Step 6.

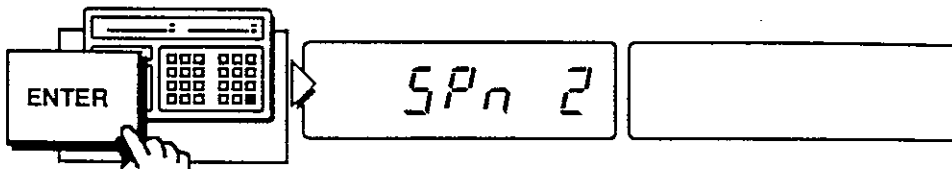

- ▶ Press the **ENTER** key.
- "SPn 2" (SPAN 2) will be displayed on the left display (there may be a number on the right display if procedure has been done before).

Step 7.

Place the SPAN calibration mass on the weighing device (in this example 20,000kg).

Step 8.

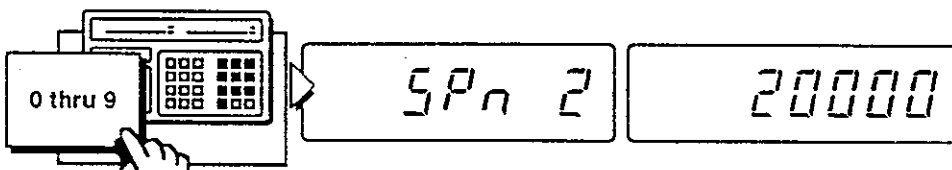

Display Example

- ▶ Use the key pad to enter in the number 20,000 (for the 20,000kg SPAN calibration mass).

Step 9.

Wait for the Motion Detection (▼MD) annunciator to go OFF.

Step 10.

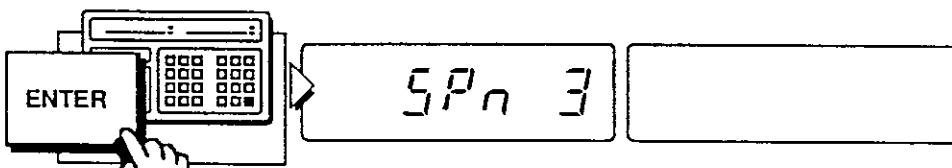

- ▶ Press the **ENTER** key.
- "SPn 3" (SPAN 3) will be displayed on the left display (there may be a number on the right display if procedure has been done before).

Note: We are not using a third SPAN point in this example, so nothing will be entered here.

- You could use another SPAN point if you wished by placing the weight on, and pressing the **ENTER** key.
- If you are not using this third SPAN point, and a number appears on the right display by "SPn 3", please press the **CLEAR** key to clear the SPAN value before continuing.

Step 10.

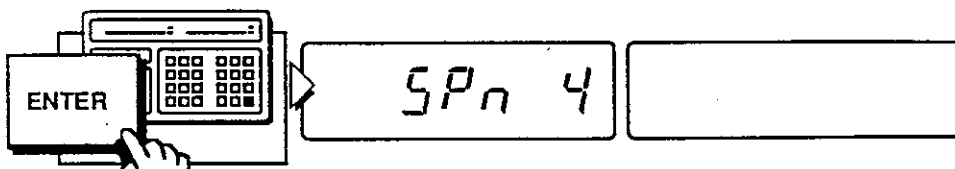

- Press the **ENTER** key.
- "SPn 4" (SPAN 4) will be displayed on the left display (there may be a number on the right display if procedure has been done before).

Note:

Again, we are not using a fourth SPAN point, so nothing will be entered here.

- You could use another SPAN point if you wished by placing the weight on, and pressing the **ENTER** key.
- If you are not using this fourth SPAN point, and a number appears on the right display by "SPn 4", please press the **CLEAR** key to clear the SPAN value before continuing.

Step 10.

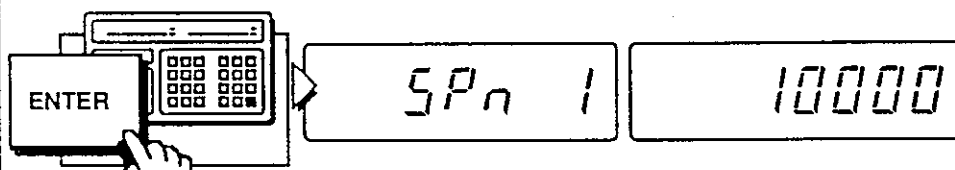

Display Example

- Press the **ENTER** key.
- "SPn 1" (SPAN 1) will be displayed on the left display.

Step 11.



- Slide the middle CAL slide-switch OFF⇐, replace the panel cover.
- "End" will be displayed.

Step 12. After about 5 seconds, the display will return to regular weighing mode. **V**



Digital Linearization Errors

Note 1: If you encounter an "Error" message, please refer to CALIBRATION ERRORS section. In addition:

DISPLAY

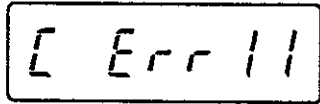

C Err 11

"C Err 11" This error will appear if the weights entered for Span Linearization were not entered from lightest to heaviest.



Gravity Compensation Function



- The AD-4322AMKII is equipped with a gravity compensation function which allows it to be calibrated in one location and then adjusted to match the acceleration of gravity at another location where it will be used.
- It is solely for this use (when the AD-4322AMKII is to be transported to a different geographical area), and it is not intended, nor needed for local or on-sight calibration.
- ⚠ SPAN Calibration should be done before the Gravity Compensation Function is used.
- ⚠ The first gravity setting, G-1, will be lost the next time you perform SPAN calibration.

Calibration of the AD-4322AMKII is required when it is initially installed, if the AD-4322AMKII is moved a substantial distance, or in accordance with local regulations. It is necessary because the weight of a mass in one location is not necessarily the same in another location. Also, with time and use, mechanical deviations can occur. "Weight" equals mass times acceleration due to Earth's field of gravity. The internationally adopted value for gravitational acceleration is 9.80665 m/s² (32.174 ft/s²) in a vacuum. However, this varies by about ±0.3 percent depending on how far you are from the Earth's center of mass. Mass distorts space in such a way that the gravitational power of attraction is inversely proportional to the square of the distance between material objects (if non-gravitational forces are ignored). So, gravitational acceleration is greatest at the poles, least at the equator and decreases with altitude.

When we weigh a mass, we are trying to find its weight expressed in pounds or kilograms. Because "g" and other factors vary from location to location, we must calibrate the AD-4322AMKII whenever we move it. Otherwise, a mass of 30kg might display 30.00kg in one location and 30.08kg in another (ie: "g" may have changed by +0.267%. $w=m \times g$). This would be an error, but it can be prevented by placing an accurate mass on the weighing device (say 30kg) and then telling the AD-4322AMKII, in effect, "this is what 30kg weighs at this location so please display 30.00kg"..... this is calibration.

- It is best to set the "g" with the actual value of gravity, measured at the location. This can be found in reference tables for the country (or area), or sometimes from a physics laboratory at a local academic institution. Also, if you know the latitude and altitude, you can use the following formula:

Helmert's formula can be used to find the value of "g", the acceleration due to terrestrial gravity, for a given latitude and altitude:

$$g = 9.806\ 16 - 0.025\ 928 \cos 2\lambda + 0.000\ 069 \cos^2 2\lambda - 0.000\ 003\ 086H$$

"g" is in m/s², "λ" means latitude and "H" is meters above sea level.

- Alternatively, please refer to the attached table for the value of "g" at various world wide locations or plot the end-user's position in terms of

latitude and altitude on the enclosed graph (see p. 129-130). **VI**



Using the Gravity Compensation Function

Step 1.

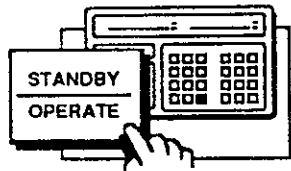

Press the **STANDBY OPERATE** key to turn the display ON (if needed), and have nothing acting on the weighing device.

Step 2.

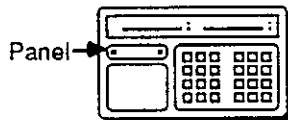

Open the panel cover on the front of the AD-4322AMKII unit by unscrewing the knobs - to expose the slide-switches.

Step 3.



Slide the middle CAL slide-switch ON⇒.

Display

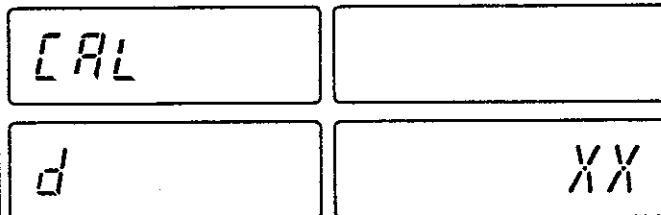

"CAL" will appear briefly followed by:

"XX" here is any previously entered minimum division.

Step 12.



Press the **ZERO** key.

Display

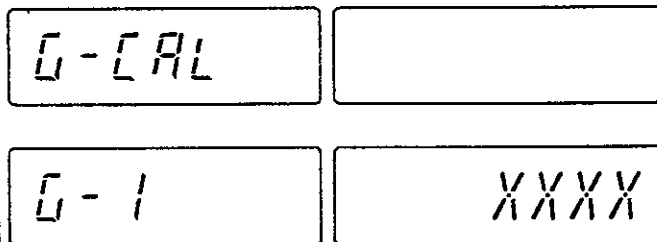

"G - CAL" (Gravity CAL) appears briefly followed by:

"XXXX" here is any previously entered gravitational setting.

○ "G - 1" (First Gravity Setting) will be displayed on the left display, and there could be a gravitational number on the right display or, it could be '0'.

Step 5.

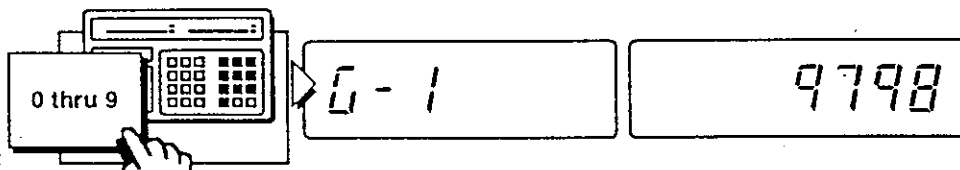

Display Example

▣ Use the key pad to enter in the gravitational value where the calibration takes place (example: Gravity = 9.798m/s²).

Step 6.

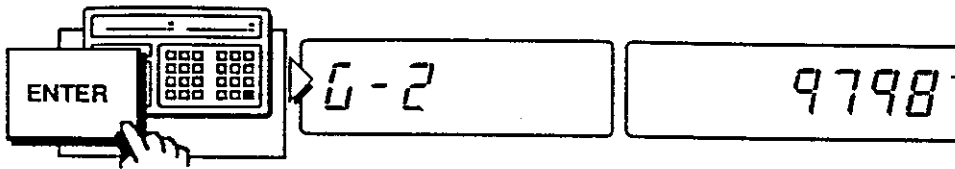

Display Example

- Press the **ENTER** key.
- "G - 2" (Second Gravity Setting) will be displayed on the left display, and the G - 1 value will remain displayed.

Step 7.

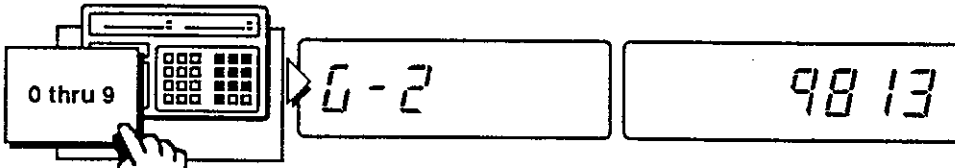

Display Example

- Use the 10-key pad to enter in the gravitational value where the AD-4322AMKII will be used (example: Gravity = 9.813m/s²).

Note: If the gravitational value where the AD-4322AMKII will be used is not known at this time, it can be entered later. If this is the case, go to Step 9.

Step 8.

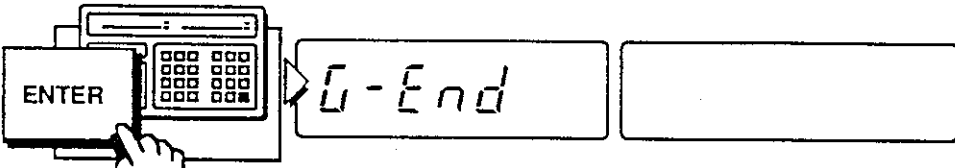

- Press the **ENTER** key.
- "G - End" (Gravity Setting End) will be displayed.

Step 9.

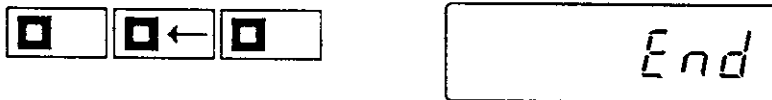

- Slide the middle CAL slide-switch OFF←, replace the panel cover.
- "End" will be displayed.

Step 10. After about 5 seconds, the display will return to regular weighing mode.



Please remember that G-1 will be lost the next time you perform SPAN calibration.



Gravity Compensation Function Errors

DISPLAY

"C Err 9" will be displayed if there is no such gravitational value as the one you set. The ratio $G2/G1$ is used with a correct range of 0.99~1.01.

DISPLAY

"C Err 10" will be displayed if there G1 has been cleared, yet there is a G2 entered.



Gravity Values at Various Locations

Amsterdam	9.813	m/s ²	Manila	9.784	m/s ²
Athens	9.800	m/s ²	Melbourne	9.800	m/s ²
Auckland NZ	9.799	m/s ²	Mexico City	9.779	m/s ²
Bangkok	9.783	m/s ²	Milan	9.806	m/s ²
Birmingham	9.813	m/s ²	New York	9.802	m/s ²
Brussels	9.811	m/s ²	Oslo	9.819	m/s ²
Buenos Aires	9.797	m/s ²	Ottawa	9.806	m/s ²
Calcutta	9.788	m/s ²	Paris	9.809	m/s ²
Capetown	9.796	m/s ²	Rio de Janeiro	9.788	m/s ²
Chicago	9.803	m/s ²	Rome	9.803	m/s ²
Copenhagen	9.815	m/s ²	San Francisco	9.800	m/s ²
Cyprus	9.797	m/s ²	Singapore	9.781	m/s ²
Djakarta	9.781	m/s ²	Stockholm	9.818	m/s ²
Frankfurt	9.810	m/s ²	Sydney	9.797	m/s ²
Glasgow	9.816	m/s ²	Taichung	9.789	m/s ²
Havana	9.788	m/s ²	Taiwan	9.788	m/s ²
Helsinki	9.819	m/s ²	Taipei	9.790	m/s ²
Kuwait	9.793	m/s ²	Tokyo	9.798	m/s ²
Lisbon	9.801	m/s ²	Vancouver, BC	9.809	m/s ²
London (Greenwich)	9.812	m/s ²	Washington DC	9.801	m/s ²
Los Angeles	9.796	m/s ²	Wellington NZ	9.803	m/s ²
Madrid	9.800	m/s ²	Zurich	9.807	m/s ²



Acceleration due to Gravity

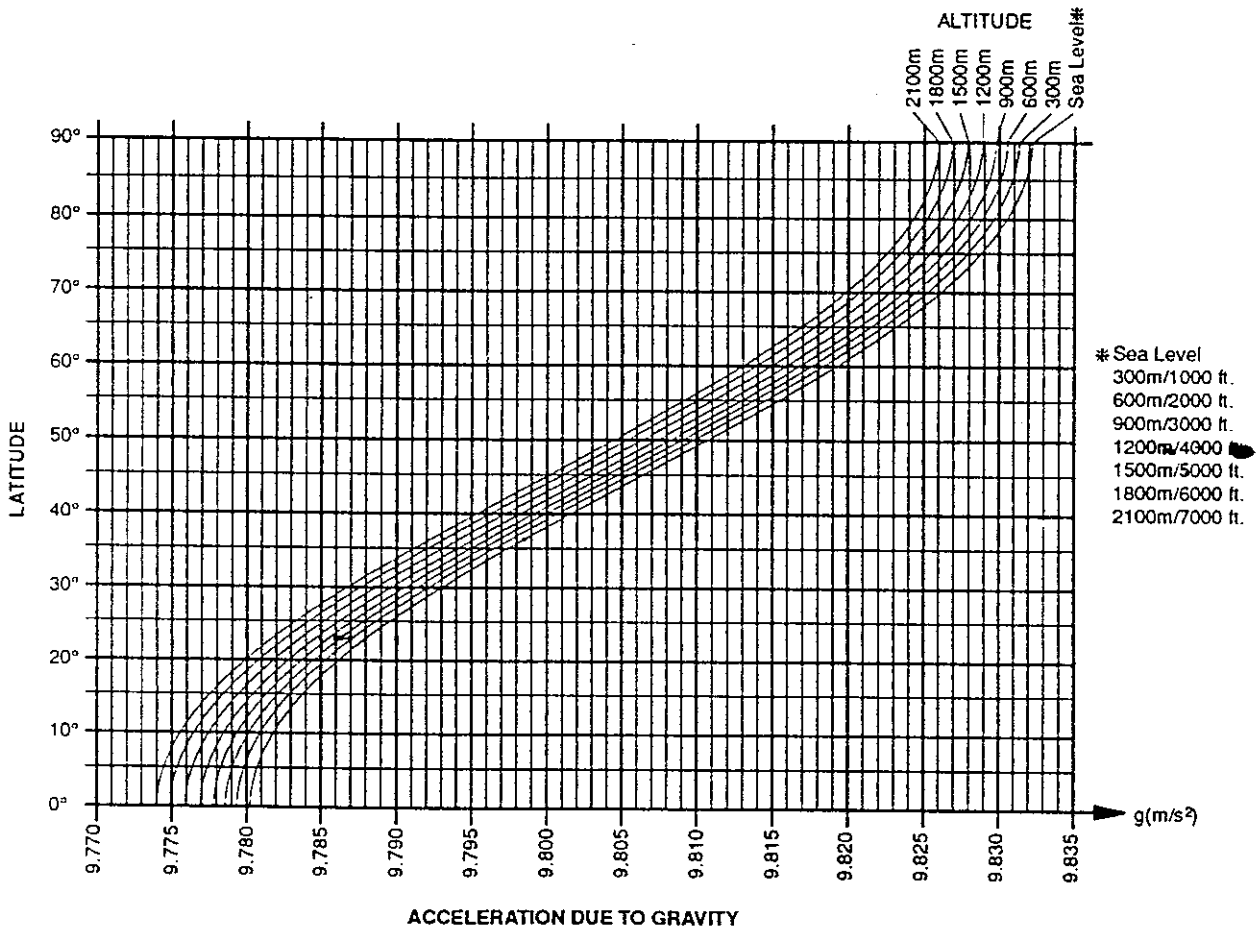



World Latitude Map

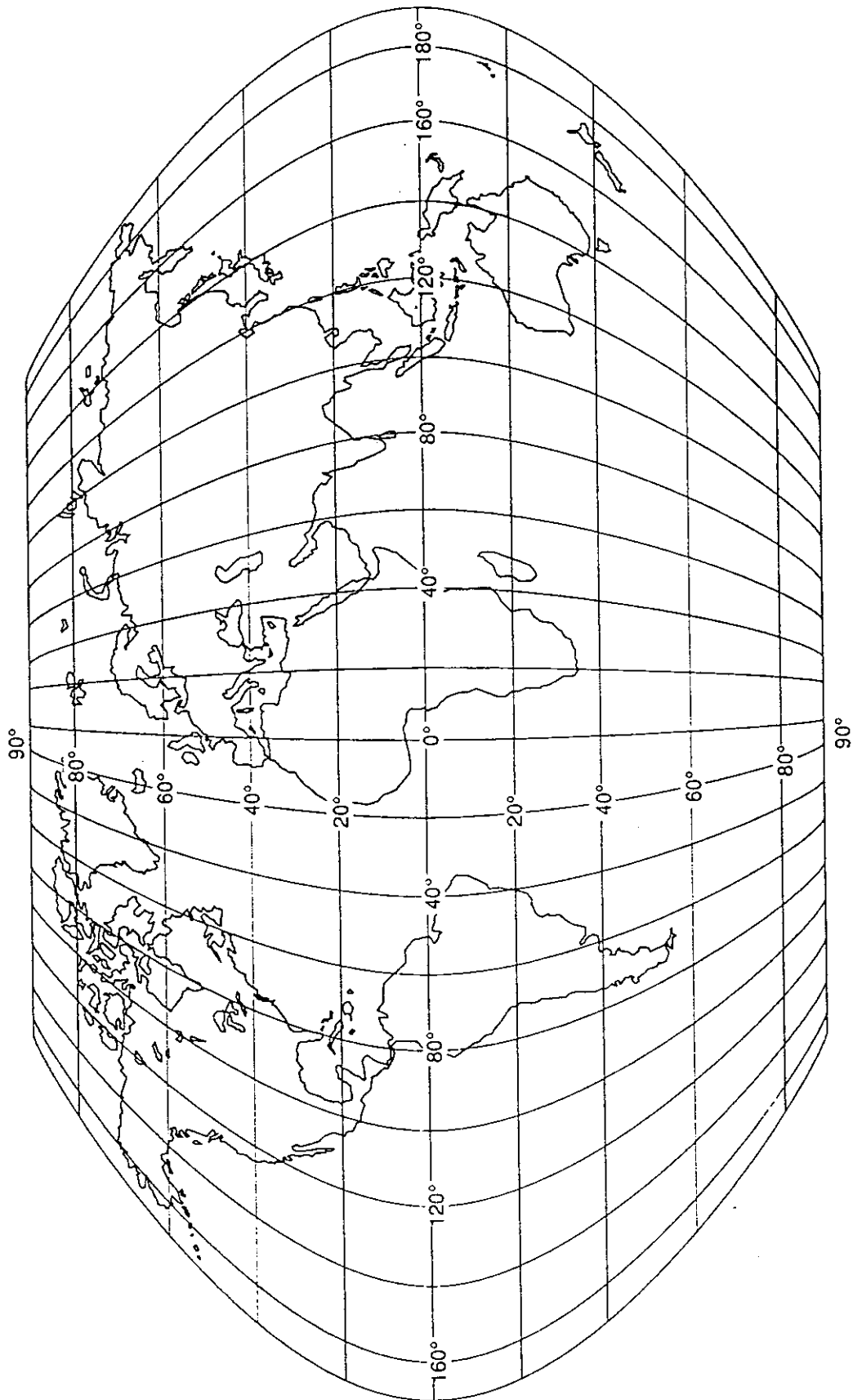

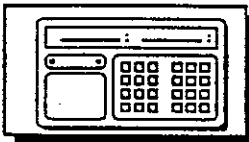

AD-4322AMKII Weighing Indicator

F-Functions



The F-Functions



There are a number of AD-4322AMKII functions that are selectable by the user - these functions control many of the important capabilities of the AD-4322AMKII. Please take a moment to look through the different F-Functions on the following pages. You are able to change any listed F-Function that you wish.

- When you enter the F-Function setting mode, and select a F-Function, you will see:

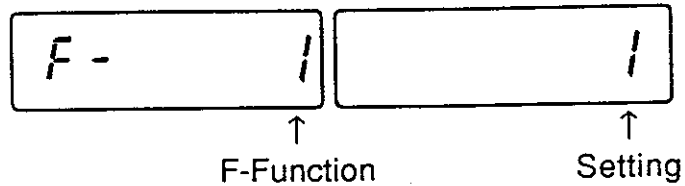

- An "F" is displayed in the left display, meaning you are in the F-Function setting mode, along with the F-Function number you are presently in.
- On the right display you will see the present setting for that F-Function.
- In this example you are in function "F 01", Decimal Point Adjustment, and the setting is "1", one place decimal point.

F-Function Title

↓

Decimal Point Adjustment			
<i>Factory Setting</i>	0	No decimal point	12345
	1	10^1	12345
	2	10^2	12345
	3	10^3	12345
	4	10^4	12345

F-Function
Setting
Description



F-Function Setting Flowchart

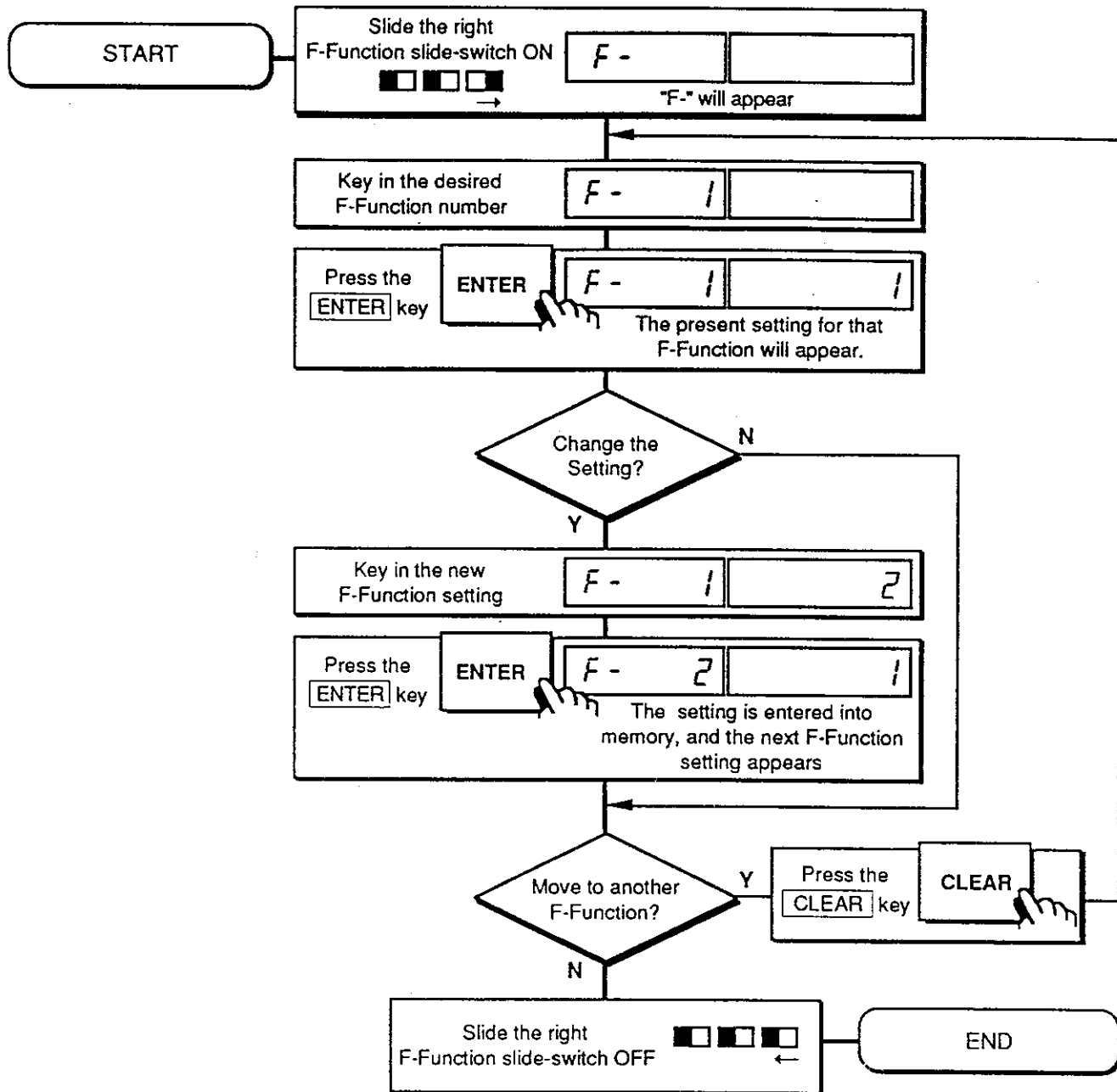



Changing the F-Functions

Step 1. Start with the display On.

Step 2.

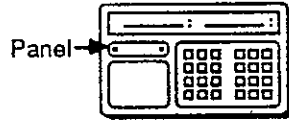

Open the panel cover on the front of the AD-4322AMKII unit by unscrewing the knobs - to expose the slide-switches.

Step 3.



Slide the right slide-switch (F-Function) ON⇒.

"F-" will be shown on the left display.

Step 4.

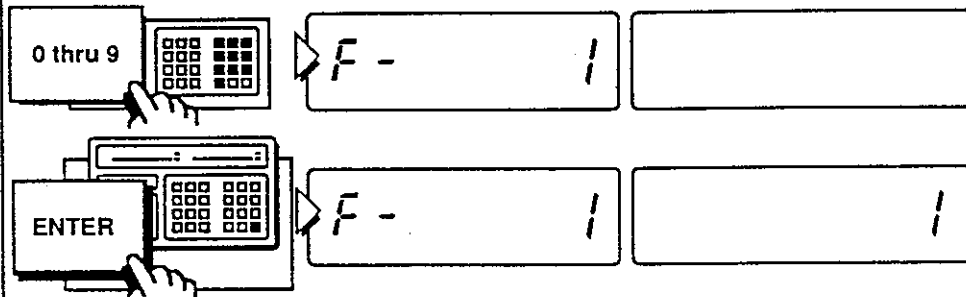

Display Examples

Key in the F-Function number that you would like (example F-1).

When the correct F-Function number is displayed, press the **ENTER** key.

The current F-Func. setting will appear on the right display.

Decimal Point Adjustment

F - 1	0	No decimal point	12345
	1	10^1	12345
	2	10^2	12345
	3	10^3	12345
	4	10^4	12345

- Step 5.
- A) If there is no change, and you are finished go to Step 6.
- B) If you wish to change the F-Function setting: key in the new setting. When you have the new setting displayed, press the **ENTER** key. You will move to the next F-Function. You may change it also, or do A) or B)

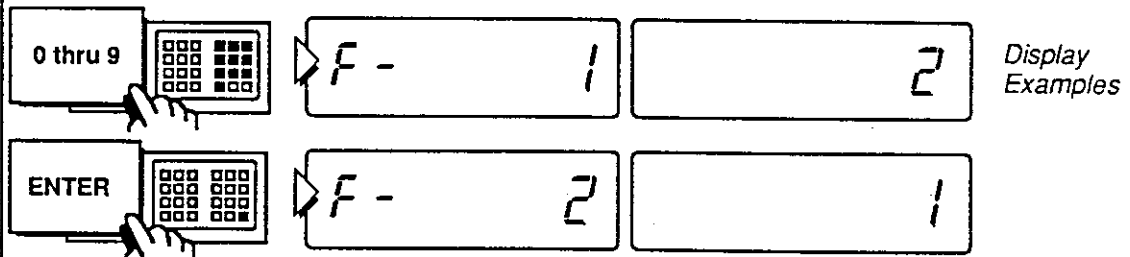

- C) If you would like to move to another F-Function, please press the **CLEAR** key and you will move back to Step 4.



Step 6.



When you are finished slide the F-Function slide switch ←OFF, replace the panel cover.

F-Function Errors

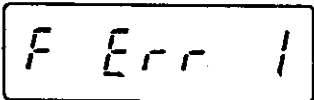
DISPLAY  "F Err 1" will be displayed if there is no such F-function number as the one you set.

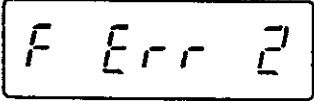
DISPLAY  "F Err 2" will be displayed if there is no such function setting as the one you set.

NOTE: If you can not enter an F-Function that has to do with one of the installed options (boards or printer), are you sure the it's installed correctly?



F- Functions And Their Settings

● = Indicates the initial factory setting.

Decimal Point Adjustment			
F - 1 ●	0	No decimal point	12345
	1	10^1	12345
	2	10^2	12345
	3	10^3	12345
	4	10^4	12345

Weighing Unit Change		
F - 2 ●	1	kg
	2	t

This setting is invalid for the International version.

Display Update Rate		
F - 3 ●	1	16 times per second
	2	8 times per second
	3	4 times per second
	4	2 times per second
	5	1 times per second
	6	0.5 times per second
	7	Hold, clear when weight is removed, or clear with CLEAR key
	8	Hold, clear with CLEAR key
	9	Peak Hold, clear with CLEAR key

Digital Filter			
F - 4	1	Weakest	<div style="display: flex; justify-content: space-around; align-items: center;"> <div style="text-align: center;"> Good Environment ◆ Bad Environment </div> <div style="border-left: 1px dashed black; height: 100px; margin: 0 10px;"></div> <div style="text-align: center;"> More Sensitive ◆ Less Sensitive </div> </div>
	2	Normal	
	3	Strong	
	4	Stronger	
<ul style="list-style-type: none"> • This function is weighing environment dependent. • When fast weighing is needed, then the filter should be weaker for a faster display response. 			

Set ZERO Range		
F - 5	1	±2% of weighing platform Full Capacity
	2	±10% of weighing platform Full Capacity
<p>The ZERO key works only if the display is within the set ±2% or ±10% limit of the weighing platform Full Capacity.</p>		

Motion Detection Condition		
F - 6	01 thru 19	<p>This modifies the "stable" condition by the counts per time of non-movement before the AD-4322AMKII recognizes the stable condition. The fewer counts per longer time are more likely to recognize the stable condition and vice versa.</p>
	00	

Automatic ZERO Tracking Compensation (rate of drift from ZERO)

<p style="font-size: 2em;">F - 7</p> <p style="font-size: 1.5em;">01 thru 19</p> <p style="font-size: 1.5em;">00 Disable</p> <p style="font-size: 0.8em;">Factory set at "13"</p>	<p style="font-size: 1.5em;">01</p> <p style="font-size: 1.5em;">1 = 2 seconds</p> <p style="font-size: 1.5em;">2 = 1.0 Div.'s</p> <p style="font-size: 1.5em;">3 = 1.5 Div.'s</p> <p style="font-size: 1.5em;">4 = 2.0 Div.'s</p> <p style="font-size: 1.5em;">9 = 4.5 Div.'s</p>	<p style="text-align: center;">seconds ↓ 01 ↑ divisions</p> <p>The ZERO Tracking Comp. function will automatically bring the display back to "zero" when there are small deviations.</p> <div style="display: flex; align-items: center;"> <div style="margin-right: 20px;"> <p>Divisions (D)</p> </div> </div>
<p>For example: Puddles of rain form on the weighing platform. Within the limits you set, the AD-4322AMarkII will ignore the rain and automatically bring the display to "zero" for easier weighing. So, if your max. capacity = 1,000kg, min. div. = 1D (1kg) and you set "F 07" function at "02" - every second the AD-4322AMarkII will check if more rain than 1kg (1 D) has collected. If it's less, then the display will automatically "zero". If it's more, it will not - you will have to press the ZERO key, and the cycle will start again at the new "zero".</p>		
<div style="display: flex; align-items: center;"> <div style="border: 1px solid black; padding: 5px; margin-right: 20px;"> <p style="font-size: 0.8em;">• "02" Setting • 1 sec - 1 Div.</p> </div> <div style="flex-grow: 1;"> </div> </div>		

AC Line Frequency	Please Check for Your Location	
F - 8	1	50 Hz
	2	60 Hz

Mode Setting		
F - 9	1	Normal Mode (setting upon shipment)
	2	Truck Scale Mode 1
	3	Truck Scale Mode 2

Normal Mode:

Conventional standard specifications.

Truck Scale Mode

There are two modes that can be accessed for using the AD-4322AMKII as a truck scale indicator. After printing, the Tare display is cleared.

In the truck Scale Mode 1, if additions to or subtractions from memory are required, use the M+ or M- keys. In the truck Scale Mode 2, if you are printing, the net weight will be automatically added to memory. You can use M+ and M- keys in this mode. Both of these modes, you can use Code M+ Memory.

ZERO Band		
F - 15 Factory Set at "5"	0 thru 255	Limit scale to judge the item to be measured is loaded or unloaded in the status of; Auto Print, Auto Addition, Display Hold, Peak Hold, and repeatedly M+ or M- key operation inhibit.
When the Function is set to 5; The AD-4322AMKII judges the item to be measured is loaded when display is more than 5. The AD-4322AMKII judges the item to be measured is unloaded when display is 5 or low.		

M+ or M- key continuous operation		
F - 16	0	Continuous operation inhibit
	1	Continuous operation enable

For External I/O Interface Option OP-02

Key Inhibit		
F 11	1	Front Keys & External Inputs are Valid
	2	Only External Inputs are Valid

Comparator Output Condition		
F 12	1	Always Available
	2	Stable Only
	3	More than Zero Band set with the function key F15
	4	Stable and more than Zero Band set with the function key F15

For Standard Serial Out

Baud Rate (serial out for display/printer)		
F 21	1	600 BPS
	2	2400 BPS

Output Data		
F 22	● 1	Same as Display
	2	Gross Data
	3	Net Data
	4	Tare Data
	5	Gross Data, Net Data, Tare Data <i>Not all devices can handle all three data at one time!</i>

Output Mode		
F 23	● 1	Stream Mode (setting upon shipment)
	2	Auto Print Mode
	3	Manual Mode
	4	Printer Mode

The Set Values 1-3 are the same as conventional specifications.

The Set Value 4 (Printer Mode) is the mode which outputs the same contents as the built-in printer. It is used when making the external printer print the same contents as the built-in printer. The print format and print mode conform to the settings of the built-in printer.

Output Availability		
F 24	● 1	Always Available
	2	Output when Stable Only

Output Mode		Time Delay (Sec.)
F 25	0	0
	1	0.5
	2	1.0
	3	1.5 (setting upon shipment)
	4	2.0
	5	2.5
	6	3.0
	7	3.5

F-25 is used to set the time data is delayed before being sent to the printer. This delay is required when an external printer, connected to the Standard Serial Output, cannot receive data while it is printing. Make this setting equal to the time it takes your printer to print one line. Set at 0 (0 sec) for the Ad-8118A, set at 3 (1.5 sec.) for the AD-8115C and AD-8121.

⚠ When F-23 is set from 1 through 3, F-25 settings are invalid.

For Parallel BCD Output Option OP-01

Output Data		
F 31 ●	1	Same as Display
	2	Gross Data
	3	Net Data
	4	Tare Data

Output Mode		
F 32 ●	1	Stream
	2	Auto Print Mode (Print when stable)
	3	Print only when PRINT key is pressed

Output Logic		
F 33 ●	1	Positive Logic
	2	Negative Logic

Output Format		
F 34 ●	1	Normal Mode (USA, International Version)
	2	Special Mode (Japan version only)

For Serial Interface Option OP-04

Baud Rate		
F 41 ●	1	600 BPS
	2	1200 BPS
	3	2400 BPS
	4	4800 BPS
	5	9600 BPS

Output Data		
F 42 ●	1	Same as Display
	2	Gross Data
	3	Net Data
	4	Tare Data
	5	Gross Data, Net Data, Tare Data <i>Not all devices can handle all three data at one time!</i>

Output Mode		
F 43	● 1	Stream Mode <i>(setting upon shipment)</i>
	2	Auto Print Mode
	3	Manual Mode
	4	Command Mode
	5	Printer Mode

The Set Values 1-4 are the same as the conventional specifications.

The Set Value 5 (Printer Mode) is the mode which outputs the same contents as the built-in printer. It is used when making the external printer print the same contents as the built-in printer. This print format and print mode conform to the settings of the built-in printer.

Output Availability		
F 44	● 1	Always Available
	2	Output when Stable Only

Output Mode		
		Time Delay (Sec.)
F 45	● 0	0
	1	0.5
	2	1.0
	3	1.5 <i>(setting upon shipment)</i>
	4	2.0
	5	2.5
	6	3.0
	7	3.5

F-45 is used to set the time data is delayed before being sent to the printer.

This delay is required when an external printer, connected to either output of the Serial Interface Option Op-04, cannot receive data while it is printing. Make this setting equal to the time it takes your printer to print one line. Set at 0 (0 sec) for AD-8118A, set at 3 (1.5 sec.) for AD-8115C and AD-8121 printers.

⚠ When F-43 is set from 1 through 4, F-45 settings are invalid.

☐ For Analog Output Option OP-07

Analog Output Data		
F 51	1	Same as Display
	2	Gross Data
	3	Net Data

Output Current at Display Zero		
F 52	00 thru 999	0.0mA though 99.9mA <i>Factory set at "4.0" mA</i>

Output Current at Full Scale		
F 53	00 thru 999	0.0mA though 99.9mA <i>Factory set at "4.0" mA</i>

See option 07 analog output for details

For Built-In Printer Option OP-08

Printer Print Format			
F 61	● 1	Display Weight	Chars./Line
	2	Tare Net Gross	24
	3	Display Weight Time and Date	
	4	Tare Net Gross Time and Date	
	5	Gross Tare Net Time and Date	
	6	Display Weight	
	7	Tare Net Gross	
	8	Display Weight Time and Date	
	9	Tare Net Gross Time and Date	
	10	Gross Tare Net Time and Date	

Although settings 1-5 and 6-10 provide the same printout, the maximum number of characters per line differs. When the printer to be connected cannot print 24 characters per line, (for example, AD-8121) set at 6-10.

When a code or I.D. number has been entered, it will print first no matter which setting is chosen. An option Op-09 is required to print the time and date.

Paper Feed After Printing		
F 62	● 1	No lines
	2	One line
	3	Two lines
	4	Four lines

Automatic Clear after Printing TOTAL		
F 63	<input checked="" type="radio"/>	1 Do Not Clear
	<input type="radio"/>	2 Clear Main Total Memory Only
	<input type="radio"/>	3 Clear Main & Code Totals
	<input type="radio"/>	4 Clear Code Total Only

Hour Mode Selection		
F 64	<input checked="" type="radio"/>	1 24 hour
	<input type="radio"/>	2 12 hour

Year Mode Selection		
F 65	<input checked="" type="radio"/>	1 International
	<input type="radio"/>	2 Japanese

The data with Code Total of 0 will be output		
F 66	<input checked="" type="radio"/>	1 All data will be output
	<input type="radio"/>	2 If accumulated value is 0, no data will be output

Digital Clock Option OP-09

Date Format		
F 71	<input type="radio"/>	1 Day / Month / Year (Intern. Standard Setting)
	<input type="radio"/>	2 Month / Day / Year (USA Standard Setting)
	<input type="radio"/>	3 Year/Month/Day (Japan Standard Setting)

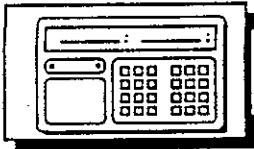

AD-4322AMKII Weighing Indicator

I/O Interfaces & Options



Standard Serial Output



The Standard Serial Output connector is for a printer, external display unit, or similar device. For example, the AD-8117 printer, or external displays: AD-8916, AD-8917 or AD-8918.

⚠ This is a standard passive 20mA current loop output and must be connected with a display or printer that can source current.

□ For Standard Serial Out

F 2 1	Baud Rate	600, 2400 Baud.
F 2 2	Output Data	Display, GROSS, NET, Tare or Gross+Net+Tare Data.
F 2 3	Output Mode	Stream, Auto Print, PRINT key, Printer
F 2 4	Output Availability	Always Available, or Stable Only
F 2 5	Print Interval	0, 0.5, 1.0, 1.5, 2.0, 2.5, 3.0, 3.5 sec.

■ Stream Mode:

In this mode data will be transmitted whenever new data becomes available. However, the sampling rate is so fast that there is a possibility the output will not be the latest data - that this case the output wave form is:

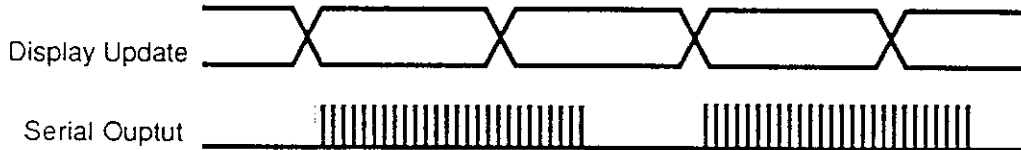

■ Auto Print Mode:

The data is sent when stable. *The display must return to zero (Less than setting value of F-15) to send again.*

■ PRINT key Mode:

The data is sent when I/O control A6 pin is shorted to the common or PRINT key is pushed.

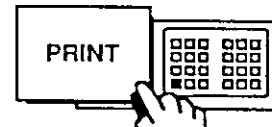

■ Printer Mode:

The Set Value 4 (Printer Mode) is the mode which outputs the same contents as the built-in printer. The print format and print mode conform to the settings of the built-in printer.

■ **Pin Assignment:**

Pin	Assignment
1	N. C.
2	Frame Ground
3	Serial Output *
4	N. C.
5	Serial Output *
6	N. C.
7	N. C.

Connector: TCS 0270

*Output has no polarity



Parallel BCD Output Option OP-01



The Parallel BCD Output Connector is for sending weight data to a printer, score board, PLC (Programmed Logic Control).

The following formats and modes are selected by F-Functions:

■ Transmission Mode:

F 3 1	Output Data	Display, GROSS, NET, or Tare Data.
F 3 2	Output Mode	Stream, Auto Print, PRINT Key.
F 3 3	Output Logic	Positive Logic, Negative Logic.
F 3 4	Output Format	Normal, Special.

■ Pin Assignment:

Pin	Signal	Pin	Signal
1	Ground (GND)	26	N. C.
2	1×10^0	27	Hi = Net Lo = Gross
3	2×10^0	28	N. C.
4	4×10^0	29	N. C.
5	8×10^0	30	Internally Used
6	1×10^1	31	N. C.
7	2×10^1	32	N. C.
8	4×10^1	33	Lo = Motion Detection
9	8×10^1	34	Lo = kg Mode
10	1×10^2	35	Lo = kg Mode
11	2×10^2	36	Lo = kg Mode
12	4×10^2	37	N. C.
13	8×10^2	38	Lo = kg Mode
14	1×10^3	39	N. C.
15	2×10^3	40	Lo Permanently
16	4×10^3	41	Lo = kg Mode
17	8×10^3	42	Lo = Negative Polarity
18	1×10^4	43	Decimal Point at 10^1
19	2×10^4	44	Decimal Point at 10^2
20	4×10^4	45	Decimal Point at 10^3
21	8×10^4	46	Decimal Point at 10^4
22	1×10^5	47	Overload
23	2×10^5	48	N. C.
24	4×10^5	49	Data Valid Trigger
25	8×10^5	50	Hold (input)

- ❑ 50 pin connector, TTL Open-Collector Output, fan-out 5, positive/negative logic. Pins 2 → 25 are data output.
- ❑ When HOLD (pin 50) input is accepted by Open-Collector Output or contact closure, output will go to hold.
- ❑ Standard Accessory..... Mating connector (1) 57-30500 (Amphenol).

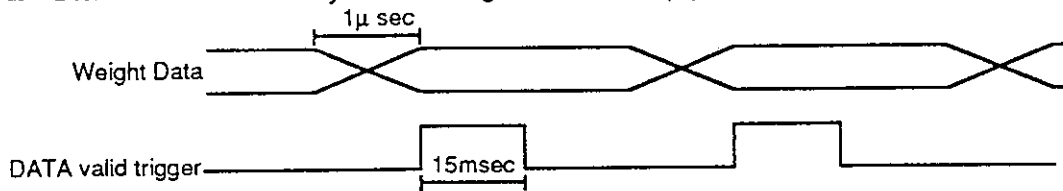

■ **BCD Output Circuit:**

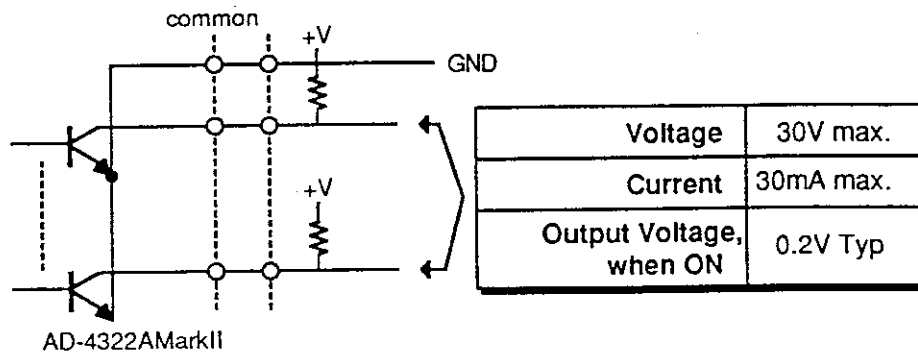

- ❑ The output circuit is an open-collector type. If you hook-up this line to TTL Logic, please add a pull-up resistor. These pull up resistor may be installed on the option board as there is a space set a side for them.

In the USA, request OP-01A for TTL use. This option comes with pull up resistors installed.

■ **Hold Input:**

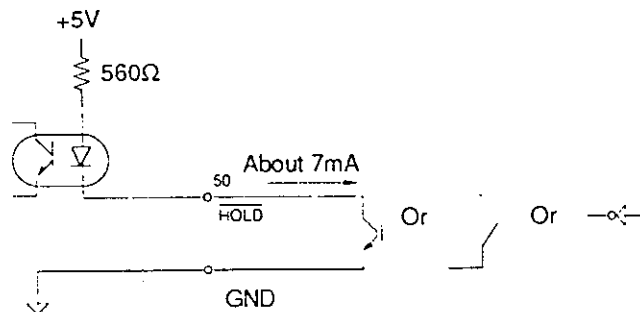

External I/O Interface Option OP-02

For External I/O Interface Option OP-02

F 11	Key Inhibit	Front Key & EXT Input available, EXT Input only.
F 12	Comparator Mode	Always available, Stable, More than setting value of Zero Band (F-15), Stable & More than setting value of Zero-Band (F-15) .

Pin Assignment:

INPUT:

Pin	Signal Name	
A-1	ZERO Input	AD-4322AMKII returns to the center of ZERO when the weighing device is empty and motion is not detected.
A-2	TARE Input	AD-4322AMKII switches to NET mode, ZERO's the display and stores the TARE weight in memory.
A-3	CLEAR Input	TARE value is cleared.
A-4	NET/GROSS Input	AD-4322AMKII switches between NET and GROSS modes.
A-5	STANDBY/OPERATE Input	AD-4322AMKII switches between STANDBY and OPERATING modes
A-6	PRINT Input.	<ul style="list-style-type: none"> When one of the data outputs is set to Manual Print Mode, this Pin will be PRINT command Input. If this command is accepted, data output will be sent one time.
A-7	N.C.	
A-8	Common	

OUTPUT:

B-1	UNDER Output	B-5	N.C.
B-2	ACCEPT Output	B-6	N.C.
B-3	OVER Output	B-7	N.C.
B-4	N.C.	B-8	N.C.

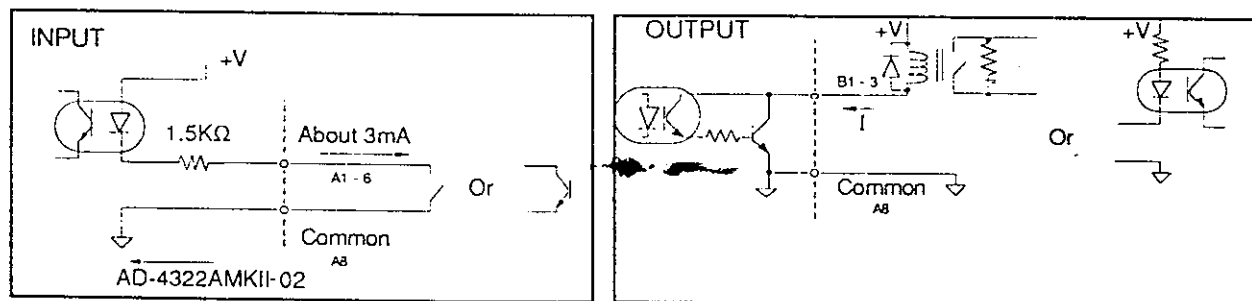

- With the above OUTPUT circuit , please use optical isolator or relay.
- The excitation (or driving) capacity of these relays are 24V 50mA DC maximum.
- The width of these inputs are at least 100msec, the interval is at least 100msec.

■ **Examples:**

□ Weight Data (NET) is 350.7kg, and not in-motion:

1	2	3	4	5	6	7	8	9	10	11	12	13	14	15	16	17	18
S	T	,	N	T	,	+	0	0	3	5	0	.	7	k	g	↵	LF

□ Weight Data (GROSS) is -350 lb, and in-motion:

1	2	3	4	5	6	7	8	9	10	11	12	13	14	15	16	17	18
U	S	,	G	S	,	-	(20H)	0	0	0	3	5	0	l	b	↵	LF

■ **Stream Mode:**

In this mode data will be transmitted whenever new data becomes available. However, the sampling rate is so fast that there is a possibility the output will not be the latest data - that this case the output wave form is:

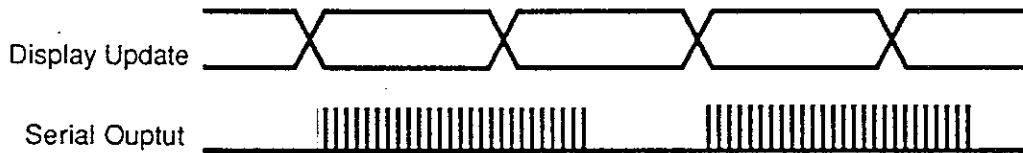

■ **Auto Print Mode:**

The data is sent when stable. *The display must return to zero (less than 6 divisions) to send again.*

■ **PRINT key Mode:**

The data is sent when I/O control A6 pin is shorted to the common or **PRINT** key is pushed.

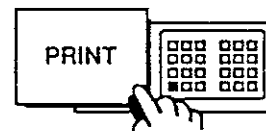

■ **Command Mode:**

In the command mode, the AD-4322AMKII is operated by a command. Almost all function of the AD-4322AMKII (i. e. setting, changing or readout of ID/TARE and Code Memory Set) can be controlled via a computer.

These commands are divided into four types and described in the following sections.

There are three types of responses when command is not accepted.

- ? $C_{R L F}$ Received command is not defined.
Received data format was different from defined format.
- E $C_{R L F}$ Error occurs when command has been received and was accepted.
- I $C_{R L F}$ the AD-4322AMKII is out of command acceptable status.

(1) Type 1

This type of command is called request command to operate the AD-4322AMKII.

When the AD-4322AMKII receives and acceptable command, it will operate corresponding to the command and will send out the received command as the response.

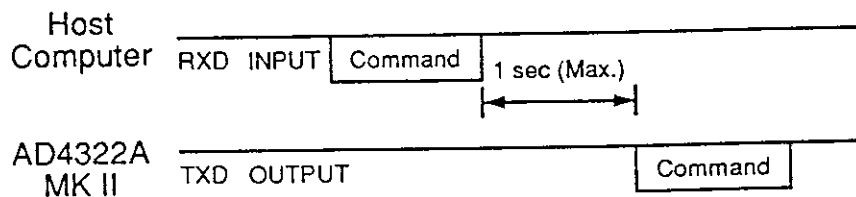

Command	Description of Command	Response of the AD-4322AMKII
Z $C_{R L F}$ or MZ $C_{R L F}$ ZERO	This command is used to set the display to ZERO . (This operation is the same as the ZERO key on the front panel.)	If an acceptable command is received, Z (or MZ) $C_{R L F}$ will be sent back by the AD-4322AMKII. In the following status, this command becomes invalid and I $C_{R L F}$ will be sent back by the AD-4322AMKII; Display is not in the Normal Weighing Mode. Gross Weight Exceeds the valid ZERO range. Unstable weighing.
T $C_{R L F}$ or MT $C_{R L F}$ TARE	This command is used to subtract the tare weight and display the tare weight on the right display. The Net Mode will be selected. (This operation is the same as the TARE key on the front panel.)	If an acceptable command is received, T (or MT) $C_{R L F}$ will be sent back by the AD-4322AMKII. In the following status, this command becomes invalid and I $C_{R L F}$ will be sent back by the AD-4322AMKII; Display is not in the Normal Weighing Mode. Gross Weight exceeds the valid TARE range. Unstable weighing.

Command	Description of Command	Response of the AD-4322AMKII
$N^{C_R L_F}$ or $MN^{C_R L_F}$ <u>NET</u>	This command is used to change display from the Gross Mode to Net Mode.	<p>If an acceptable command is received, N (or MN) $C_R L_F$ will be sent back by the AD-4322AMKII.</p> <p>In the following status, this command becomes invalid and I $C_R L_F$ will be sent back by the AD-4322AMKII;</p> <p>Display is not in the Normal Weighing Mode.</p>
$G^{C_R L_F}$ or $MG^{C_R L_F}$ <u>GROSS</u>	This command is used to change display from the Net Mode to Gross Mode.	<p>If an acceptable command is received, G (or MG) $C_R L_F$ will be sent back by the AD-4322AMKII.</p> <p>In the following status, this command becomes invalid and I $C_R L_F$ will be sent back by the AD-4322AMKII;</p> <p>Display is not in the Normal Weighing Mode.</p>
$S^{C_R L_F}$ or $MS^{C_R L_F}$ <u>STANDBY</u>	This command is used to change the AD-4322AMKII from the Operate Mode to Standby Mode.	<p>If an acceptable command is received, S (or MS) $C_R L_F$ will be sent back by the AD-4322AMKII.</p> <p>In the following status, this command becomes invalid and I $C_R L_F$ will be sent back by the AD-4322AMKII;</p> <p>Display is not in the Operate Mode and Normal Weighing Mode.</p>
$O^{C_R L_F}$ or $MO^{C_R L_F}$ <u>OPERATE</u>	This command is used to change the AD-4322AMKII from the Standby Mode to Operate Mode.	<p>If an acceptable command is received, O (or MO) $C_R L_F$ will be sent back by the AD-4322AMKII.</p> <p>In the following status, this command becomes invalid and I $C_R L_F$ will be sent back by the AD-4322AMKII.</p> <p>Display is not in the Operate Mode and Normal Weighing Mode.</p>
$C^{C_R L_F}$ or $CT^{C_R L_F}$ <u>CLEAR TARE</u>	<p>This command is used to clear the TARE . The Tare Weight on the right display becomes blank.</p> <p>(This operation is the same as the CLEAR key on the front panel.)</p>	<p>If an acceptable command is received, C (or CT) $C_R L_F$ will be sent back by the AD-4322AMKII.</p> <p>In the following status, this command becomes invalid and I $C_R L_F$ will be sent back by the AD-4322AMKII.</p> <p>Display is not in the Normal Weighing Mode.</p>
$AM^{C_R L_F}$ <u>ADD MEMORY</u>	<p>This command is used to add weighing data being displayed to Main Total. If code number is set, the weighing data is added to Code Total.</p> <p>(This operation is the same as the M+ key on the front panel.)</p>	<p>If an acceptable command is received, AM $C_R L_F$ will be sent back by the AD-4322AMKII.</p> <p>In the following status, this command becomes invalid and I $C_R L_F$ will be sent back by the AD-4322AMKII;</p> <p>Display is not in the Normal Weighing Mode.</p>

Command	Description of Command	Response of the AD-4322AMKII
$SM^{C_R L_F}$ <u>S</u> UBTRACT <u>M</u> EMORY	<p>This command is used to subtract weighing data being displayed from Main Memory Total. If code number is set, the weighing data is subtracted from Code Total.</p> <p>(This operation is the same as the M- key on the front panel.)</p>	<p>If an acceptable command is received, $SM^{C_R L_F}$ will be sent back by the AD-4322AMKII.</p> <p>In the following status, this command becomes invalid and $I^{C_R L_F}$ will be sent back by the AD-4322AMKII;</p> <p>Display is not in the Normal Weighing Mode.</p>
$CI^{C_R L_F}$ <u>C</u> HANGE <u>I</u> D	<p>This command is used to recall the Tare Weight having I.D. number indicated by XXXXXXXX from the ID/TARE memory.</p> <p>The recalled tare weight is displayed on the right display.</p> <p>The Net Mode will be selected.</p>	<p>If an acceptable command is received, $CI^{C_R L_F}$ will be sent back by the AD-4322AMKII.</p> <p>When XXXXXXXX is displayed with space () (20H), $CI^{C_R L_F}$ being displayed will be sent back by the AD-4322AMKII.</p> <p>In the following status, this command becomes invalid and $I^{C_R L_F}$ will be sent back by the AD-4322AMKII;</p> <p>Display is not in the Normal Weighing Mode.</p>
$DI^{C_R L_F}$ <u>D</u> ELETE <u>I</u> D	<p>This command is used to clear the Tare Weight having I.D. number indicated by XXXXXXXX from the ID/TARE memory.</p> <p>If its I.D. number is recalled, the Tare Weight is also cleared.</p> <p>When XXXXXXXX is displayed with space () (20H), Tare Clear is executed.</p>	<p>If an acceptable command is received, $DI^{C_R L_F}$ will be sent back by the AD-4322AMKII.</p> <p>In the following status, this command becomes invalid and $I^{C_R L_F}$ will be sent back by the AD-4322AMKII;</p> <p>Display is not in the Normal Weighing Mode.</p>
$EI^{C_R L_F}$ <u>E</u> RASE <u>I</u> D	<p>This command is used to clear all data stored in the ID/TARE memory.</p>	<p>If an acceptable command is received, $EI^{C_R L_F}$ will be sent back by the AD-4322AMKII.</p> <p>In the following status, this command becomes invalid and $I^{C_R L_F}$ will be sent back by the AD-4322AMKII;</p> <p>Display is not in the Normal Weighing Mode.</p>
$CC^{C_R L_F}$ <u>C</u> HANGE <u>C</u> ODE	<p>This command is used to recall the Code Set Value (Code Number, Tare, Low Limit Setpoint and High Weight Setpoint) having code number indicated by XXXXXXXX from the code memory.</p> <p>If code number indicated by XXXXXXXX does not exist in the memory, the AD-4322AMKII sets its code number.</p>	<p>If an acceptable command is received, $CC^{C_R L_F}$ will be sent back by the AD-4322AMKII.</p> <p>When XXXXXXXX is displayed with space () (20H), $CC^{C_R L_F}$ being displayed will be sent back by the AD-4322AMKII.</p> <p>In the following status, this command becomes invalid and $I^{C_R L_F}$ will be sent back by the AD-4322AMKII;</p> <p>Display is not in the Normal Weighing Mode.</p>

Command	Description of Command	Response of the AD-4322AMKII
DC XXXXXXXX C _R L _F DELETE CODE	This command is used to clear the Code Set Value having CODE number indicated by XXXXXXXX from the code memory. If its code number is recalled, the Code Number, Tare Low Limit Setpoint and High Limit Setpoint are also cleared. When XXXXXXXX is displayed with space () (20H), code number recalled will be cleared.	If an acceptable command is received, DC XXXXXXXX C _R L _F will be sent back by the AD-4322AMKII. In the following status, this command becomes invalid and I C _R L _F will be sent back by the AD-4322AMKII; Display is not in the Normal Weighing Mode.
EC C _R L _F ERASE CODE	This command is used to clear all data stored in the code memory.	If an acceptable a command is received, EC C _R L _F will be sent back by the AD-4322AMKII. In the following status, this command become invalid and I C _R L _F will be sent back by the AD-4322AMKII; Display is not in the Normal Weighing Mode.
DT XXXXXXXX C _R L _F DELETE TOTAL	This command is used to clear the Code Total having CODE number indicated by XXXXXXXX from the code memory. When XXXXXXXX is displayed with space () (20H), Main Memory Total will be cleared.	If an acceptable command is received, DT XXXXXXXX C _R L _F will be sent back by the AD-4322AMKII. In the following status, this command becomes invalid and I C _R L _F will be sent back by the AD-4322AMKII; Display is not in the Normal Weighing Mode.
ET C _R L _F ERASE TOTAL	This command is used to clear Main Memory Total and Code Total.	If an acceptable command is received, ET C _R L _F will be sent back by the AD-4322AMKII. In the following status, this command becomes invalid and I C _R L _F will be sent back by the AD-4322AMKII; Display is not in the Normal Weighing Mode.
PT XXXXXXXX C _R L _F PRINT TOTAL	This command is used to print the Code Total CODE number indicated by XXXXXXXX. When XXXXXXXX is displayed with space () (20H), Main Memory Total will be printed.	If an acceptable command is received, PT XXXXXXXX C _R L _F will be sent back by the AD-4322AMKII. In the following status, this command becomes invalid and I C _R L _F will be sent back b the AD-4322AMKII; Display is not in the Normal Weighing Mode.

Command	Description of Command	Response of the AD-4322AMKII
P W PRINT WEIGHT	This command is used to print the weighing value being displayed. (This operation is the same as the PRINT key on the front panel.)	If an acceptable command is received, PW ^{C_RL_F} will be sent back by the AD-4322AMKII. In the foollowing status, this command becomes invalid and I ^{C_RL_F} will be sent back by the AD-4322AMKII; Display is not in the Normal Weighing Mode. Unstable weighing.
P D PRINT DATE/TIME	This command is used to print the date and time. (This operation is the same as the "3" key used with the ENTER key on the fornt panel.)	If an acceptable command is received, PD ^{C_RL_F} will be sent back by the AD-4322AMKII. In the following status, this command becomes invalid and I ^{C_RL_F} will be sent back by the AD-4322AMKII; Display is not in the Normal Weighing Mode.
P F PRINT FEED	This command is use to feed paper one line.	If an acceptable command is received, PF ^{C_RL_F} will be sent back by the AD-4322AMKII. In the following status, this command becomes invalid and I ^{C_RL_F} will be sent back by the AD-4322AMKII; Display is not in the Normal Weight Mode.

(2) Type 2

This type of command is called a data request command to readout data from the AD-4322AMKII.

When the AD-4322AMKII receives an acceptable command, data requested by command will be sent back.

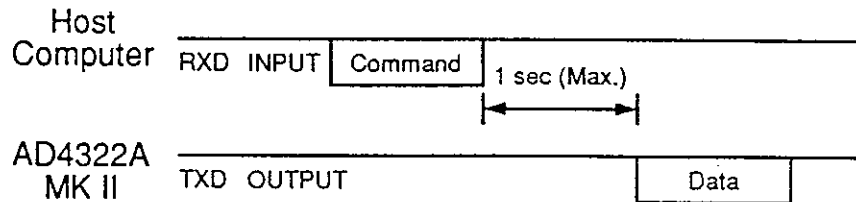

Command	Description of Command	Response of the AD-4322AMKII
$R^C R^L F$ or $RW^C R^L F$ <u>READ</u> <u>WEIGHT</u>	This command is used to output the weighing value being displayed.	If an acceptable command is received, the weighing value being displayed will be sent back by the AD-4322AMKII. Data is output using format 1. In the following status, this command becomes invalid and $I^C R^L F$ will be sent back by the AD-4322AMKII. Display is not in the Normal Weighing Mode.
$RIXXXXXXXX$ $C^R L^F$ <u>READ ID</u>	This command is used to output the ID/TARE data (I.D. number and tare weight) having I.D. number indicated by XXXXXXXX from the ID/TARE memory. When XXXXXXXX is displayed with space () (20H), tare weight being displayed on the right display and I.D. number will be output.	If an acceptable command is received, Tare Weight and I.D. number will be sent back by the AD-4322AMKII. Data is output using format 2. In the following status, this command becomes invalid and $I^C R^L F$ will be sent back by the AD-4322AMKII; Display is not in the Normal Weighing Mode. If the I.D. number indicated by XXXXXXXX is not stored in the ID/TARE memory, $E^C R^L F$ will be sent back.
$RCXXXXXXXX$ $C^R L^F$ <u>READ CODE</u>	This command is used to output the Code Set Value (Code Number, Tare Weight, Low Setpoint and High Setpoint) having code number indicated by XXXXXXXX from the ID/TARE memory. When XXXXXXXX is displayed with space () (20H), Code Number, Tare Weight, Low Setpoint and High Setpoint being displayed will be output.	If an acceptable command is received, Code Number, Tare Weight, Low Setpoint and High Setpoint will be sent back by the AD-4322AMKII. Data is output using format 3. In the following status, this command becomes invalid and $I^C R^L F$ will be sent back by the AD-4322AMKII; Display is not in the Normal Weighing Mode. If the code number indicated by XXXXXXXX is not stored in the code memory, $E^C R^L F$ will be sent back.

Command	Description of Command	Response of the AD-4322AMKII
RTXXXXXXXX ^C _R ^L _F READ TOTAL	This command is used to output the Code Total having code number indicated by XXXXXXXX. When XXXXXXXX is displayed with space () (20H), Main Memory total will be output.	If an acceptable command is received, Code Number, Code Total and Code Total-In will be sent back by the AD-4322AMKII. Data is output using format 4. In the following status, this command becomes invalid and I ^C _R ^L _F will be sent back by the AD-4322AMKII; Display is not in the Normal Weighing Mode. If the CODE number having indicated by XXXXXXXX is not stored in the code memory, E ^C _R ^L _F will be sent back.

(3) Type 3

This type of command is called a setting command to set data into ID/TARE memory or code memory of the AD-4322AMKII.

When the AD-4322AMKII receives an acceptable command, it will send back the command. The next data to be set will be sent back to the AD-4322AMKII.

When the AD-4322AMKII accepts the next data, its data will be sent back.

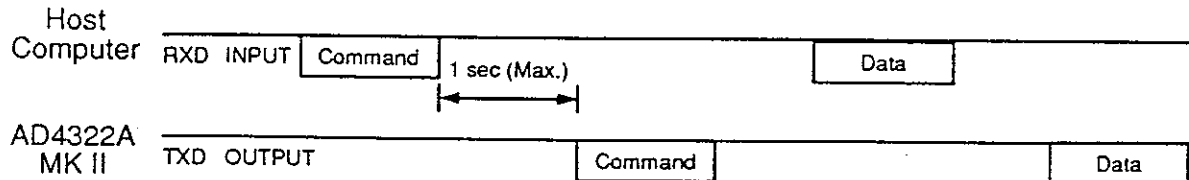

Command	Description of Command	Response of the AD-4322AMKII
SI XXXXXXXX C _R L _F SET ID	This command is used to store the I.D. number having code number indicated by XXXXXXXX and the next Tare Weight into the ID/TARE memory. When XXXXXXXX is displayed with space () (20H), Tare Weight will not be stored and AD-4322AMarkII enters into tare weight subtracting measurement mode.	If an acceptable command is received, SI XXXXXXXX C _R L _F will be sent back by the AD-4322AMKII. In the following status, this command becomes invalid and I C _R L _F will be sent back by the AD-4322AMKII; Display is not in the Normal Weighing Mode. When SI XXXXXXXX C _R L _F is sent back, data can be received. Send Tare Weight to the AD-4322AMKII using format 5. The AD-4322AMKII will send Tare Weight. If data format of Tare Weight is improper, ? C _R L _F will be sent back.
SC XXXXXXXX C _R L _F SET CODE	This command is used to store the code number indicated by XXXXXXXX and the next Code Set Value into the CODE memory. When XXXXXXXX is displayed with space () (20H), Tare Weight subtracting measurement mode.	If an acceptable command is received, SC XXXXXXXX C _R L _F will be sent back by the AD-4322AMKII. In the following status, this command becomes invalid and I C _R L _F will be sent back by the AD-4322AMKII; Display is not in the Normal Weighing Mode. When SC XXXXXXXX C _R L _F is sent back, data can be received. Send Tare Weight, Low Setpoint and High Setpoint to the AD-4322AMKII using format 6. The AD-4322AMKII will send Tare Weight, Low Setpoint and High Setpoint. If data format of Tare Weight is improper, ? C _R L _F will be sent back.

(4) Type 4

This type of command is called a data request command used to recall all data stored in the ID/TARE memory or code memory of the AD-4322AMKII.

There are three request commands as follows;

GI to request ID/TARE

GC to request Code Set Value

GT to request Code Total

When the AD-4322AMKII accepts these commands, first data will be sent back.

When the host computer requests the next data, the computer sends GN CR LF. The AD-4322AMKII will send the next data.

When the host computer sends GA CR LF, data that has been sent previously will be sent back.

If no next data is existed (all data have been output) when the AD-4322AMKII receives GN CR LF, all zero data will be sent back.

When the host computer received all zero data, send GQ CR LF to quit data request. The AD-4322AMKII will send back GQ CR LF.

When the host computer sends GQ CR LF before receiving all zero data, the AD-4322AMKII will send GQ CR LF.

When the command (GI, GC or GT) has been sent, send GQ at the end to quit the operation. If no GQ is sent, the AD-4322AMKII no longer will accept the command.

The data is output from lowest I.D. or code number.

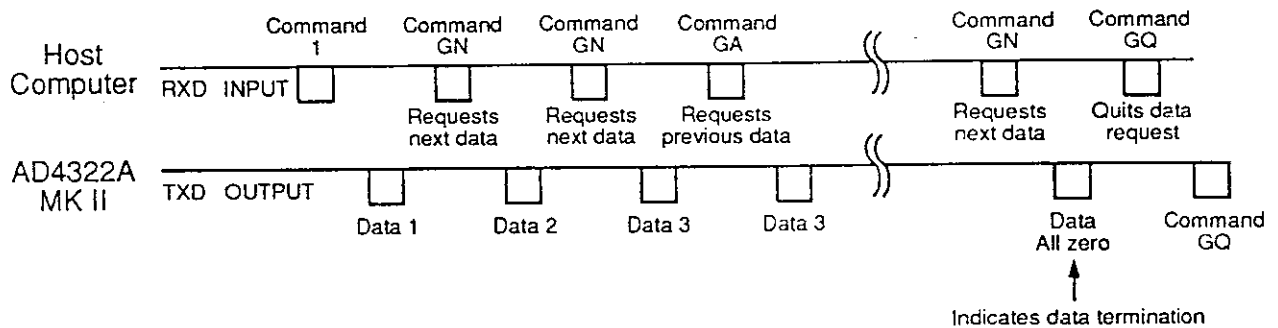

Command	Description of Command	Response of the AD-4322AMKII
$G I^{C_R L_F}$ GET ID	This command is used to output all ID/TARE data.	<p>If an acceptable command is received, first data (having lowest I.D. number) will be sent back by the AD-4322AMKII using data format 2.</p> <p>In the following status, this command becomes invalid and $I^{C_R L_F}$ will be sent back by the AD-4322AMKII;</p> <p>Display is not in the Normal Weighing Mode.</p> <p>When no data is stored in the ID/TARE memory, all zero data (0000000000000000 $C_R L_F$) will be sent back.</p> <p>When the AD-4322AMarkII receives this command, commands except GN, GA and GQ cannot be accepted.</p> <p>After GQ command is received, the AD-4322AMKII returns to command waiting status. Therefore, send GQ last after $G I^{C_R L_F}$ is sent.</p>
$G C^{C_R L_F}$ GET CODE	This command is used to output all Code Set Value (Code number, Tare, Low Setpoint and High Setpoint).	<p>If an acceptable command is received, first data (having lowest code number) will be sent back by the AD-4322AMKII using data format 3.</p> <p>In the following status, this command invalid and $I^{C_R L_F}$ be sent back by the AD-4322AMKII;</p> <p>Display no data is stored in the CODE memory, all zero data (0000000000000000+0000000+000000 $C_R L_F$) will be sent back.</p> <p>When the AD-4322AMKII receives this command, commands except GN, GQ and GQ cannot be accepted.</p> <p>After GQ command is received, it returns to command waiting status. Therefore, send GQ last after $G I^{C_R L_F}$ is sent.</p>

Command	Description of Command	Response of the AD-4322AMKII
$GT^{C_R L_F}$ $GET\ IOTAL$	<p>This command is used to output all Code Total.</p>	<p>If an acceptable command is received, first data (having lowest code number) will be sent back by the AD-4322AMKII using data format 4.</p> <p>In the following status, this command becomes invalid and $I^{C_R L_F}$ will be sent back by the AD-4322AMKII;</p> <p>Display is not in the Normal Weighing Mode.</p> <p>When no data is stored in the CODE memory, all zero data (00000000 + 00000000 + 00000 $C_R L_F$) will be sent back.</p> <p>When the AD-4322AMKII receives this command, commands except GN, GA and GQ cannot be accepted.</p> <p>After GQ command is received, it returns to command waiting status. Therefore, send GQ last after $GI^{C_R L_F}$ is sent</p>
$GA^{C_R L_F}$ $GET\ AGAIN$	<p>This command is used to output data sent previously.</p> <p>This command is used when no data is received due to a data error by the host computer.</p>	<p>This command is used to output data sent previously.</p>
$GN^{C_R L_F}$ $GET\ NEXT$	<p>This command is used to output the next data.</p>	<p>This command is used to output the next data followed by data sent previously.</p>
$GQ^{C_R L_F}$ $GET\ QUIT$	<p>This command is used to quit the data request.</p>	<p>When the AD-4322AMKII receives this command, data output will be terminated and GA, GN and GQ cannot be accepted.</p> <p>The AD-4322AMKII returns to command waiting status.</p>

■ Data Format:

Format 1

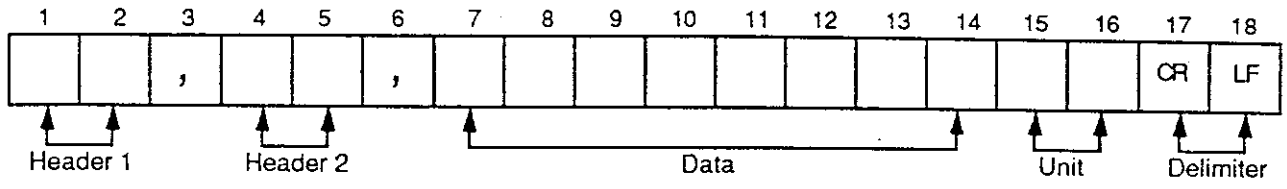

□ Header 1:

- OL - Overload (Underload)
- ST - Display is Stable (no motion)
- US - Display is Unstable (in-motion)

□ Header 2:

- NT - NET Data
- GS - GROSS Data
- TR - TARE Data

□ Weight Data TXD by ASCII numerals plus:

- 2D (HEX) "-" (minus)
- 20 (HEX) " " (space)
- 2B (HEX) "+" (plus)
- 2E (HEX) "." (decimal point)

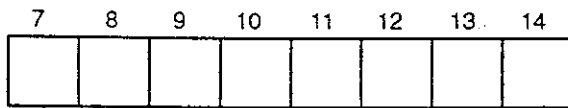

6 Digits of Weight Data, plus Decimal Point

Space when there is no Decimal Point

+ or - (Polarity is '+' when the weight data is zero)

□ Unit:

- kg = 6B (HEX) 67 (HEX)
- t = 2φ (HEX) 74 (HEX)
- lb = 6C (HEX) 62 (HEX)

□ Delimiter:

- CF = Carriage Return = φD (HEX)
- LF = Line Feed = φA (HEX)

Format 2

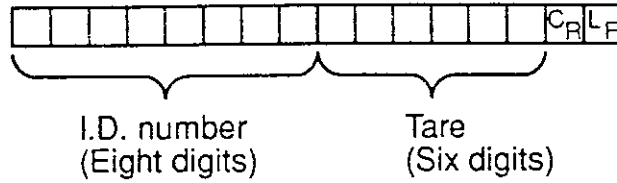

Decimal point is omitted. When received command is RI _____ C_R L_F, all I.D. numbers become space _ (20H).

Example: I,D, number = 1234
Tare = 250.0 kg

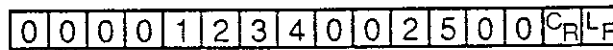

Format 3

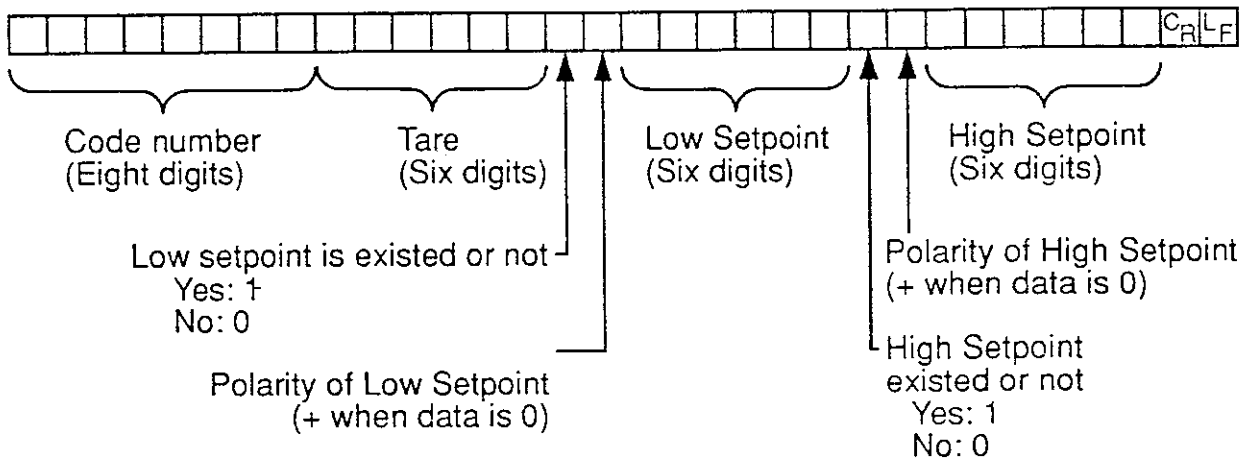

Decimal point is omitted.
When received command is RT _____ C_R L_F, all code numbers become space _ (20H).
When received Setpoint value "does exist", the value becomes +000000.

Example: Code number = 5678
Tare = 250.0kg
Low Setpoint = 595.0kg
High Setpoint = 695.0kg

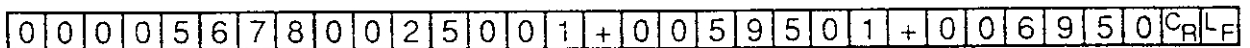

Format 4

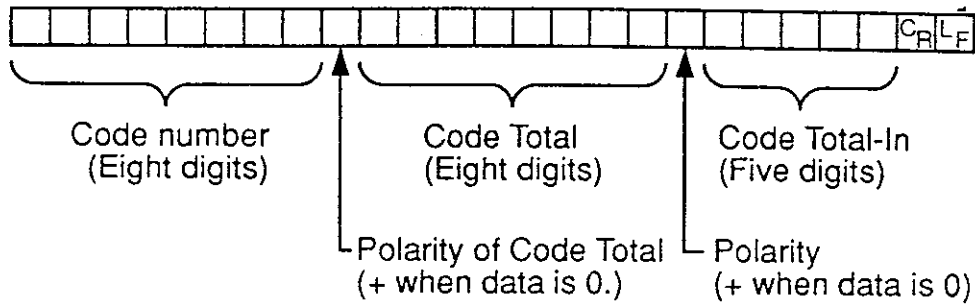

Decimal point is omitted.

When received command is RT _____ C_R L_F:

All code numbers become space _ (20H).
 Code Total becomes Main Memory Total.
 Code Total-In becomes Main Memory Total-In.

Example: Code number = 5678
 Code Total = 7857.5kg
 Code Total-In = 37

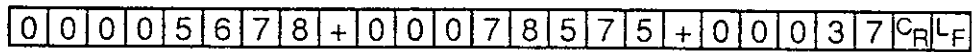

Format 5

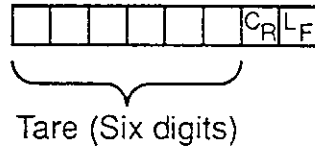

Decimal point is omitted.

Example: Tare = 250.0kg

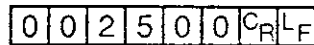

Format 6

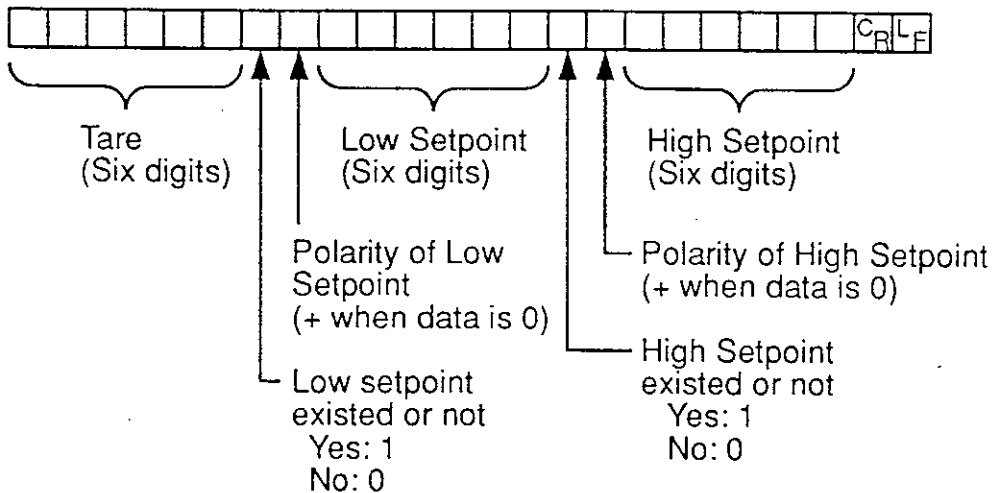

Decimal point is omitted.

When no Tare weight setting is required, input 000000.

When no Low Setpoint or High Setpoint is required, input +000000 for that setpoint.

Example: Code number = 5678
Tare = 250.0kg
Low Setpoint = 0.0kg
High Setpoint = 0.0kg

0	0	2	5	0	0	1	+	0	0	0	0	0	0	1	+	0	0	0	0	0	0	C _R	L _F
---	---	---	---	---	---	---	---	---	---	---	---	---	---	---	---	---	---	---	---	---	---	----------------	----------------

■ **Printers and Other Devices:**

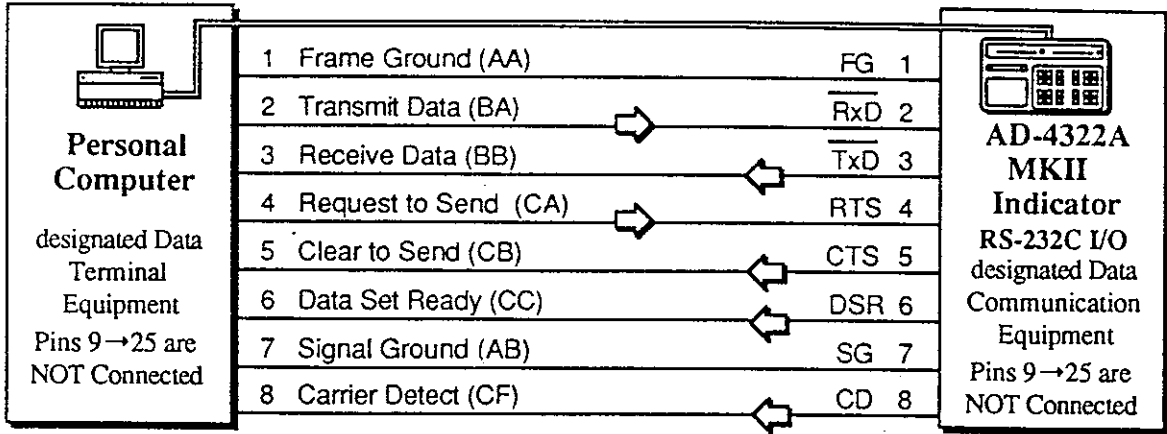

■ **RS-232C Circuit:**

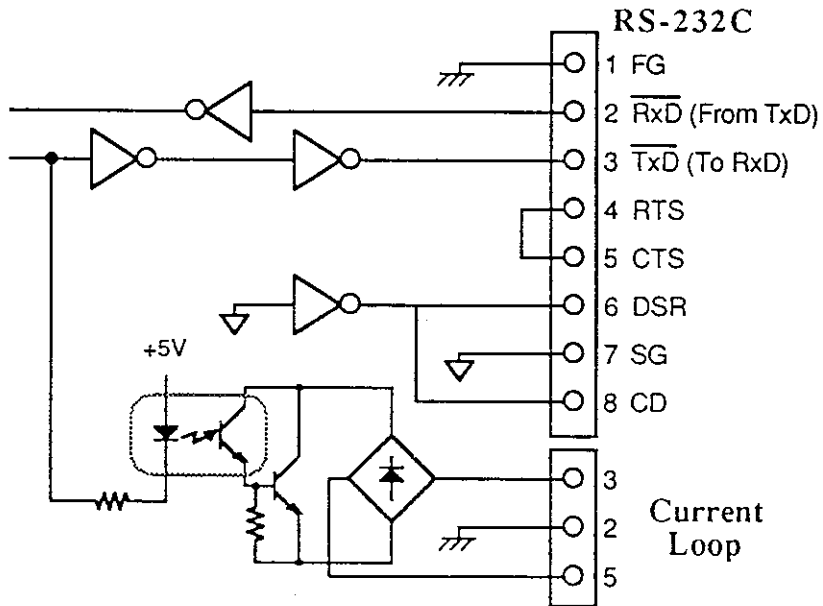



Analog Output Option OP-07



This option is used to transmit the Analog weight data to equipment that is controlled by an Analog signal.

■ Transmission Mode:

The following formats and modes are selected by F-Functions:

For Analog Output Option OP-07

F 51	Analog Output Data	Display, Gross, or Net Data.
F 52	Analog Output at Zero	Selectable from 0.0mA to 99.9mA.
F 53	Analog Output at Full Scale	Selectable from 0.0mA to 99.9mA.

■ Specifications:

Output level	4~20mA effective range. Output range is approx.2mA to 22mA.
Resolution	more than 1/1000.
Temperature Coefficient	±(0.015% of rdg + 0.01mA)/°C
Max. Load Resistor	500Ω Max.

- The output current when the weight is "0", and at maximum capacity, can be set from 0.0mA to 99.9mA by F-Functions F-52 & F-53.
- For example, to convert current to voltage:

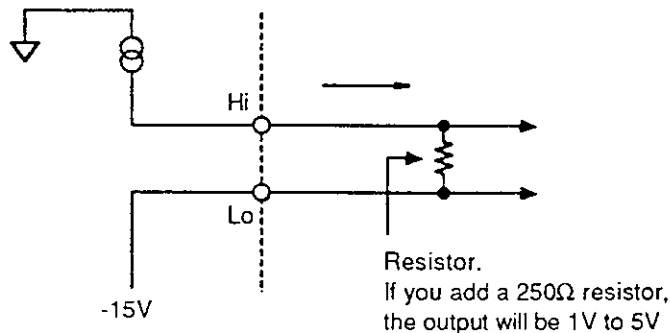

- Caution!!** This resistor must be high enough for the power consumption. If a 500Ω resistor is used, power consumption will be:

$$W = i^2 R = (0.02)^2 \times 500 = 0.2(W).$$

W = power

i = output current

R = Resistor

It should be a 1/2W type resistor and have a very low temperature coefficient.

- Do not connect any GND line, body GND, or similar device.
- Accessory:** BNC type plug: BNC-P-58U.

Setting Output Current:

Output Current can be scaled by F-Functions F-52 and F-53. The setting range is 0.0mA to 99.9mA, by steps of 0.1mA. This simulated value is calculated by the following formula:

$$I_{OUT} = I_z + \frac{\text{weight}}{\text{capacity}} \times (I_M - I_z) \text{ (if } 2\text{mA} \leq I_{OUT} \leq 22\text{mA)}$$

I_{OUT} = Current
 I_z = Output at Zero
 I_M = Output at Max. Capacity

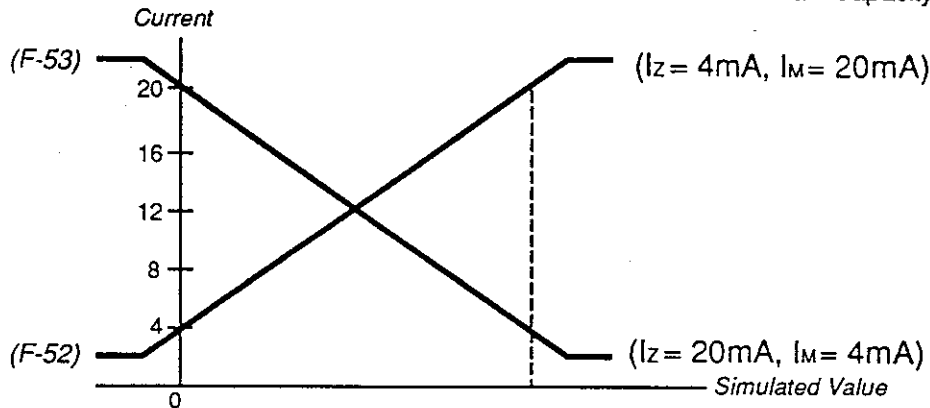

Example:

A weighing system has a Max. Capacity of 10,000kg. If you want the current to be 4mA at ZERO display, and 20mA at 1/2 capacity then:

$$I_M = \frac{\text{capacity}}{\text{simulated value}} \times (I_{OUT} - I_z) + I_z$$

$$I_M = \frac{10,000\text{kg}}{5,000\text{kg}} \times (20\text{mA} - 4\text{mA}) + 4\text{mA}$$

$$= 36\text{mA}$$

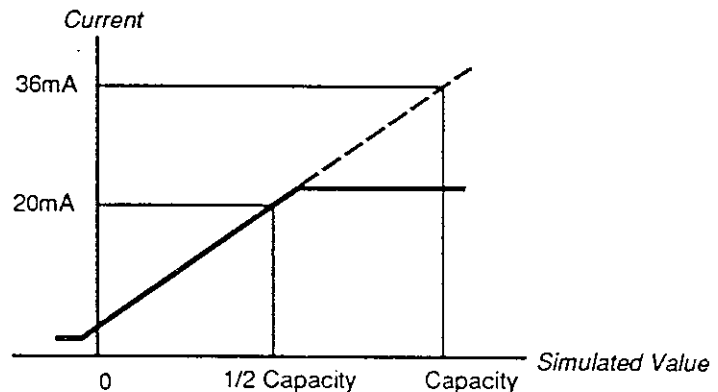

When ANALOG OUTPUT AT FULL SCALE (F-53) is set at 36mA, and ANALOG OUTPUT AT ZERO (F-52) is set at 4mA, then at 1/2 capacity (5,000kg) the output current will be 20mA.

⚠ The maximum output will be saturated at 22mA.

□ **Accessory:** BNC type plug: BNC-P-58U.

Analog Connector:

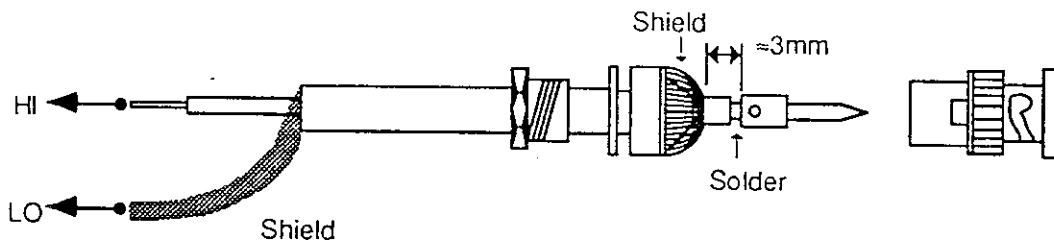



Built-In Printer Option OP-08



This option is factory or dealer installed.

■ Specifications:

Type	Built-in thermal, 5 x 7 dot matrix.	
Format	Weight (Tare, Net, Gross)	Memory Totals (M+)
	Code Number	Event Totals (M+)
	I.D. Number	Comparator results
	Date/Time (OP-09)	Auto Functions ON/OFF

■ Controlling F-Functions:

Below are summaries, please refer to the following F-Functions for actual settings.

For Built-In Printer Option OP-08

F 61	Printer Output Format	Various Selectable.
F 62	Paper Feed after Printing	0, 1, 2, or 4 lines.
F 63	Auto Clear after Printing TOTAL	No, Main Total Only, Main & Code Total
F 64	Hour Mode	24 hour, or 12 hour.

Printouts with Digital Clock Option OP-09

F 71	Date Format	DD/MM/YYYY or MM/DD/YYYY.
------	-------------	---------------------------

Changing the Printer Paper



This procedure is for changing the paper roll for the optional built-in printer (OP-08). When the red line appears on the printer printout, it means that it is time to replace the paper roll.

- Step 1. Loosen the two printer cover plate screws, then remove the printer unit from the AD-4322AMKII. **DO NOT PULL THE CABLE TOO HARD!**

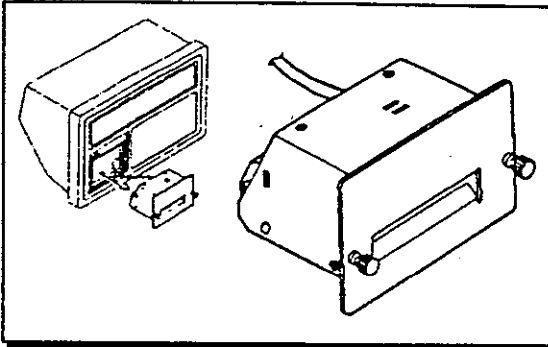

- Step 2. Open the rear cover and remove the old paper roll.

- Step 3. Drop in the new roll with the roll end facing towards the printer mechanism as shown.

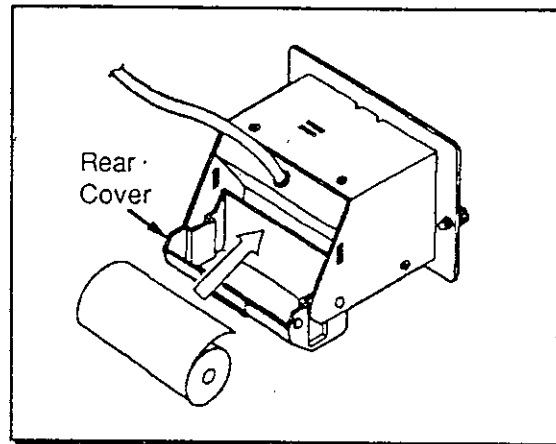

- Step 4. Close the rear cover, making sure that the paper feeds through the gap between the cover and the casing.

- Step 5. Loop the paper down, around – then into the printer mechanism.

- Step 6. Press the **FEED** key until it feeds out the front of the printer unit.

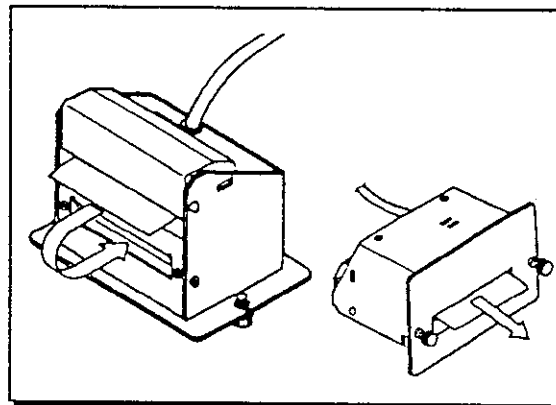
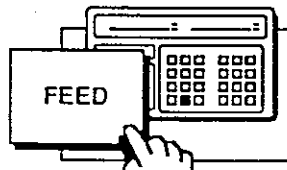

- Step 7. Replace the printer unit into AD-4322AMKII, making sure that the cable is replaced correctly. 



The Digital Clock Option OP-09



With the optional digital clock, the time and date can be added to the optional built-in printer output (OP-08).

Printouts with Digital Clock Option OP-09

F 71	Date Format	DD/MM/YYYY or MM/DD/YYYY.
------	-------------	---------------------------

To Set the Clock

Step 1.

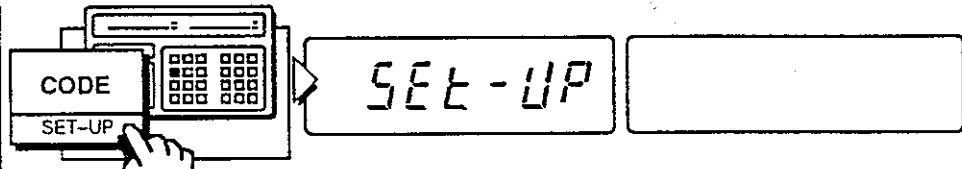

- ▶ From the weighing mode, press and hold the **CODE SET-UP** key for five seconds until "SET-UP" appears.

Step 2.

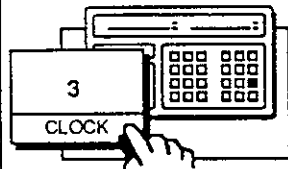

- ▶ Press the **CLOCK** key.
- The display will show the Hour, Minute, Month, Day and Year presently entered into the AD-4322AMKII, with the first digit flashing (see F-Function 71 for date order, p.145).

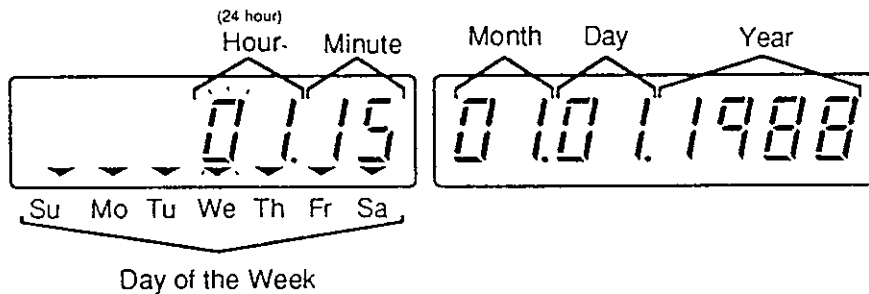

Display Example

Step 3.

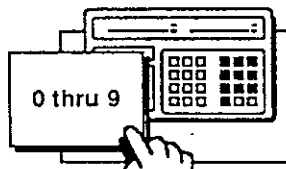

You may now use the **0** through **9** keys to enter/replace the present time and date. Please read the following notes and then enter/replace the time/date digits.

Notes:

The hour must be set by using 24 hour (military) time. Even though it is set using 24 hour, the printout can be in 12 hour A.M./P.M. mode if set that way (see F-Function F-64, p.145).

Hour examples:

00 = 12A.M. Midnight	12 = 12P.M. Noon
01 = 1A.M.	13 = 1P.M.
06 = 6A.M.	18 = 6P.M.
09 = 9A.M.	21 = 9P.M.

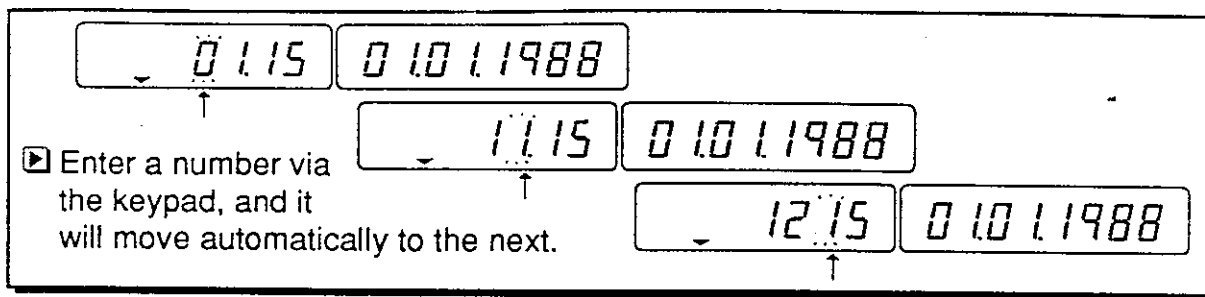

If the digit doesn't need to be changed, press the **ENTER** key



If you enter the wrong digit, press the **CLEAR** key

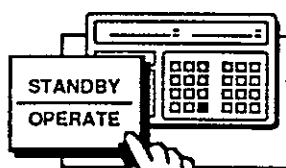

To ESCAPE, not saving any changes, press the **STANDBY OPERATE** key

- Enter:
- 1) Hour
 - 2) Minute
 - 3) Month
 - 4) Day
 - 5) Year
 - 6) Weekday (next step)

Step 4.



After the last time/date digit has been entered, use the **0** through **6** keys to enter the present day of the week the triangle cursors ▼ will represent on the display.

0 = Sunday
1 = Monday
2 = Tuesday

3 = Wednesday
4 = Thursday

5 = Friday
6 = Saturday

Display

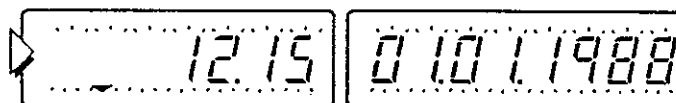

- When all time/date digits are entered, all the display digits will blink, along with a triangle cursor ▼.

Step 5.

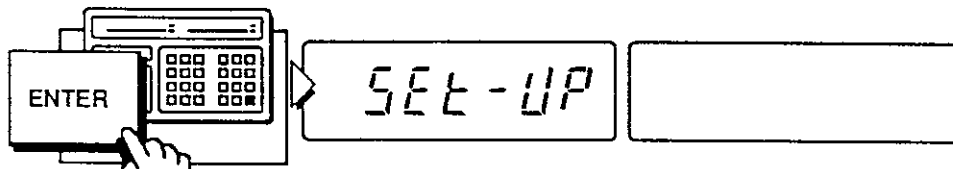

- ▶ When you have the correct settings, press the **ENTER** key.
 ○ "SEt - UP" will be displayed.





If you have made an error in the entry of the time/date, the AD-4322AMKII will return you to start over again (Step 3). Below are some of the errors that you may have made :

- The hour you entered was not between "00" and "23" ("00" = 12 midnight, "12" = noon).
- The minute entered was not between "00" and "59".

- The month you entered was not between "1" and "12" ("01" = January, "12" = December).
- The day you entered was not between "1" and "31" or appropriate for that month (i.e: there is no Feb. 31st).
- The year entered was not between "1980" and "2079".

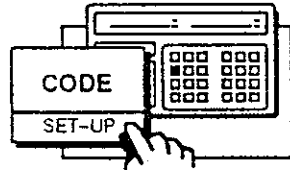
Step 6.



Press and hold the  key for five seconds until the display returns to the weighing mode. 



Connection To An External Printer



To use the statistical calculation and data collecting functions of Models AD-8118A, AD-8118B, AD-8121, and AD-8115A/B printers, set the Model AD-4322AMKII to the Stream Mode or the Print Key Mode.

This chapter describes connection of the external printer (AD-8118A, AD-8121, or AD-8115C) to use as a Dump Printer.

First, adjust the character length, parity and stop bit of the external printer connected to the AD-4322AMKII.

The AD-4322AMKII has a 7-bit character length, even parity, and 1 stop bit.

Next, set the Baud Rate and Output Mode using the appropriate F Functions. Setting items and descriptions are as follows. You do not have to set any data for F-22, F-24, F-42, and F-44.

When Connecting Through Standard Serial Output

Setting Item	Function No	Set Value	Description
Baud rate	F-21	1, 2	600, 2400
Output data	F-23	4	Printer mode
Interval	F-25	0-7	0 to 3.5 sec. (increment of 0.5 sec.)delay
Printout	F-61	1-10	Refer to F-61, page 144

When Connecting Through Option Op-04 RS-232C/Current Loop

Setting Item	Function No	Set Value	Description
Baud rate	F-41	1-5	600, 1200, 2400, 4800, 9600, baud for RS232C. 600, 2400 for Current Loop.
Output data	F-43	5	Printer mode
Interval	F-45	0-7	0 to 3.5 sec. (increment of 0.5 sec.)delay
Printout	F-61	1-10	Refer to F-61, page 144

When connecting through the current loop, set F-41 to 1-3 (600-2400)

Connection Examples

When connecting the AD-4322AMKII and AD-8118A, there are three connecting methods, through standard current loop, optional (Op-04) current loop or optional (Op-04) RS-232C. When connecting the AD-8118A, set the AD-8118A for Dumb Print Mode.

Standard Current Loop

AD-4322AMKII _____ AD-8118A

Function No.	Set Values	Description
F-21	1 or 2	600 or 2400 baud
F-23	4	Printer Mode
F-25	0	0 sec.
F-61	1-5	

Current Loop (Op-04)

AD-4322AMKII _____ AD-8118A

Function No.	Set Values	Description
F-41	1 or 3	600 or 2400 baud
F-43	5	Printer Mode
F-45	0	0 sec.
F-61	1-5	

RS-232C (Op-04)

AD-4322AMKII _____ AD-8118A

Function No.	Set Values	Description
F-41	1 or 3	600 or 2400 baud
F-43	5	Printer Mode
F-45	0	0 sec.
F-61	1-5	

When connecting the AD-4322AMKII and AD-8115C, there are two connecting methods; through standard current loop, or optional (Op-04) current loop.

Standard Current Loop

AD-4322AMKII _____ AD-8115C

Function No.	Set Values	Description
F-21	2	2400 baud (setting upon shipment)
F-23	4	Printer Mode
F-25	3	1.5 sec.
F-61	1-5	

Current Loop (Op-04)

AD-4322AMKII _____ AD-8115C

Function No.	Set Values	Description
F-41	3	2400 baud (setting upon shipment)
F-43	5	Printer Mode
F-45	3	1.5 sec.
F-61	1-5	

When connecting the AD-4322AMKII and AD-8121, there are three connecting methods: through standard current loop, option (Op-04) RS-232C or option (Op-04) current loop. When connecting the AD-8121 to current loop, you need an adaptor cable (Op-01 of AD-8121) . It is also necessary to change over the input of the AD-8121 to current loop.

Standard Current Loop

AD-4322AMKII _____ AD-8121

Function No.	Set Values	Description
F-21	2	2400 baud (setting upon shipment)
F-23	4	Printer Mode
F-25	3	1.5 sec.
F-61	6-10	

Current Loop (Op-04)

AD-4322AMKII _____ AD-8121

Function No.	Set Values	Description
F-41	3	2400 baud (setting upon shipment)
F-43	5	Printer Mode
F-45	3	1.5 sec.
F-61	6-10	

RS-232C (Op-04)

AD-4322AMKII _____ AD-8121

Function No.	Set Values	Description
F-41	3	2400 baud (setting upon shipment)
F-43	5	Printer Mode
F-45	3	1.5 sec.
F-61	6-10	



Panel Mounting Kit Option OP-10



Attach the PANEL MOUNTING KIT to the AD-4322AMKII unit as shown.

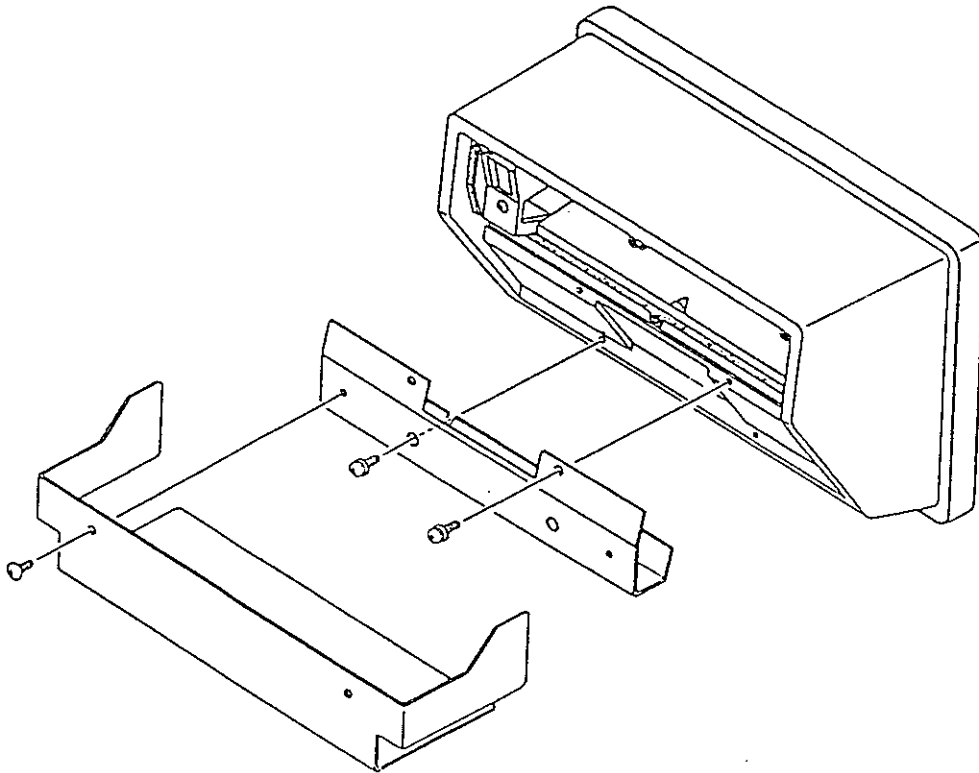
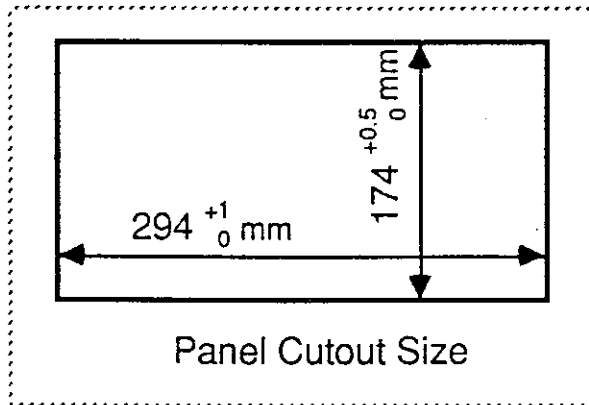



Wall Mounting Kit Option OP-11



Attach the WALL MOUNTING KIT to the AD-4322AMKII unit, and then to the wall as shown.

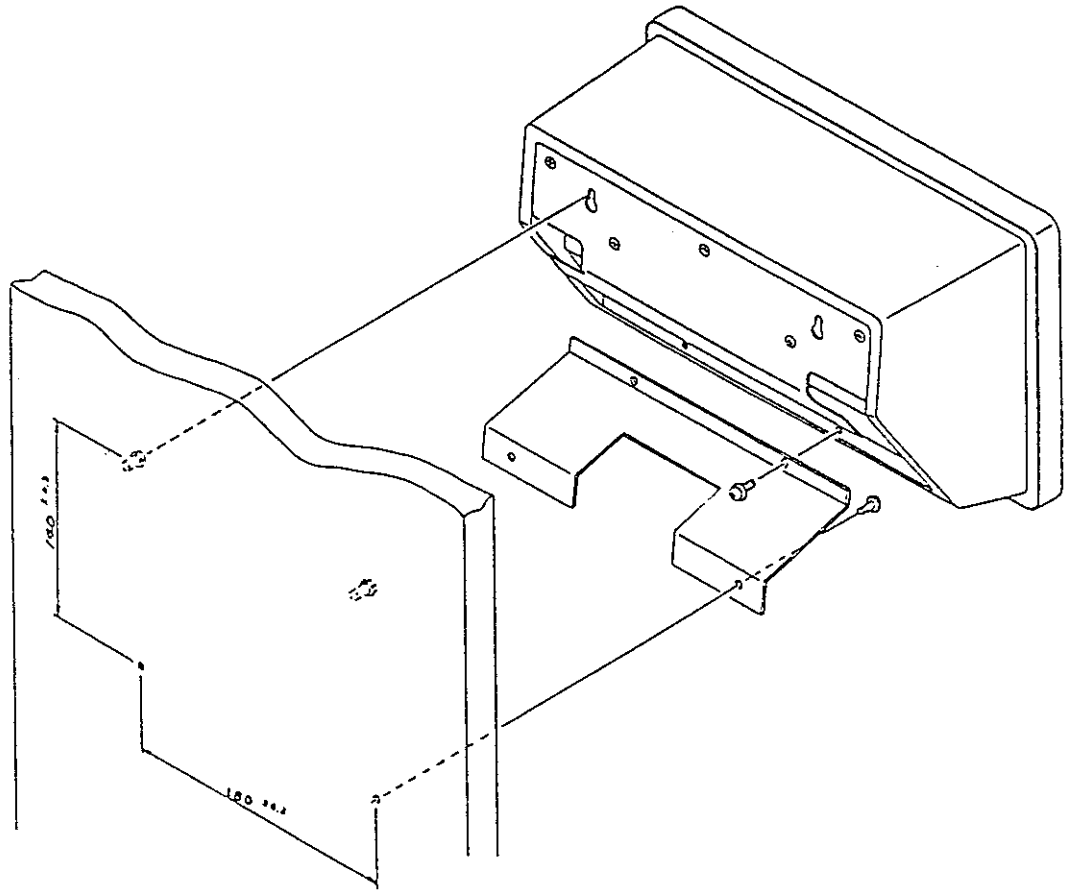



Dimensions

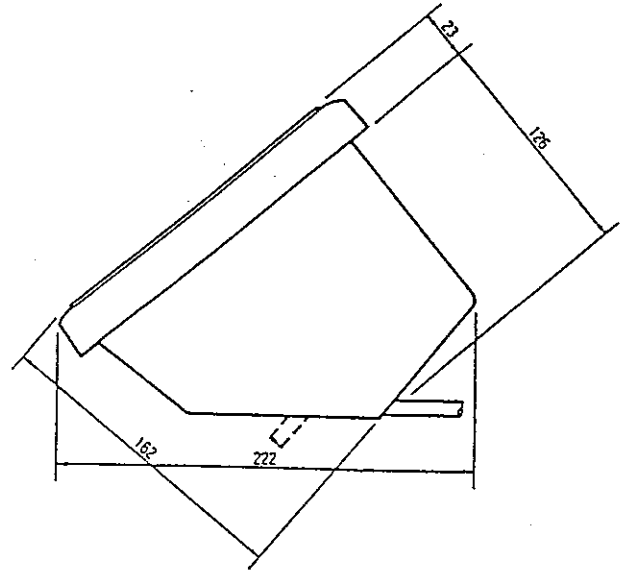
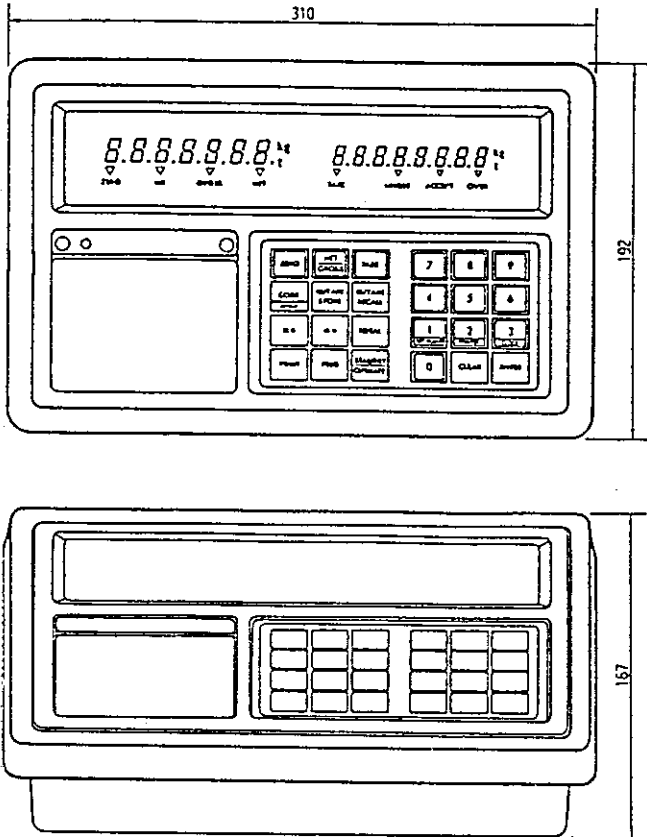



Index

Displays

- "ALL Id" Display, 50
- "ALL tL" (All CODE TOTALs) Display, 72
- "Auto Add-off" Display, 39
- "Auto Add-on" Display, 39
- "C Err" Displays, 119, 123, 128
- "C totAL" Display, 69
- "C totAL in xx" Display, 71
- "C totAL O.F." (Overflow) Display, 36, 69
- "C-OFF" (Comparator Off) Display, 42, 45
- "C-On" (Comparator On) Display, 42, 45
- "COdE" (Code) Display, 66
- "Error no Id" Display, 49
- "F Err" Display, 135
- "Id" Display, 49
- "O. F. Display", 36, 69
- "SP - HI" (high limit setpoint) Display, 43, 44
- "SP - LO" (Setpoint - low) Display, 42, 45
- "totAL O.F." (Overflow) Display, 36
- "totAL XXX" Display, 36

A

- About Calibration Terms, 110
- ACCEPT Annunciator, 5, 41
- AD-8117 Printer, 147
- AD-8916~8918, External Displays, 147
- Adding/Subtracting To Main Memory TOTAL, 36
- Adding/Subtracting to the CODE TOTAL, 69
- Analog Output Connector, 10
- Annunciators, 4
- Auto Main Memory Total ADD Mode, To Set, 39

B

- Basic Operation, 24

C

- Calibration Procedural Notes, 118
- Calibration:
 - Compensation Flowchart, 113
 - Decimal Place, 118
 - Digital Linearization, 120
 - Digital Linearization Errors, 123
 - Digital Linearization Flowchart, 114
 - Errors, 119
 - Flowchart, 112
 - Full Procedure, 115
 - Gravity Compensation Function, 124
 - Gravity Compensation Function Errors, 128
 - Maximum Capacity, 116
 - Minimum Division, 115
 - Procedural Notes, 118
 - Setting the Gravity Comp. Function, 126
 - Span Calibration, 117
 - Terms, 109
 - Terms, About, 110
 - Zero Calibration, 117
- CLEAR Key, 8

Clear:

- A CODE TOTAL, 74
- A Stored ID/Tare, 52
- All CODE TOTAL's, 76
- All Stored ID/Tare's, 52
- Main Memory TOTAL, 38

CLOCK/3 Key, 8

Clock:

- Option OP-09, 174
- To Print Time, 96
- To Set the Clock, 174

CODE (SET-UP) Key, 6

Code Function:

- Adding/Subtracting to the CODE TOTAL, 69
- CODE TOTAL Memory, 69
- CODE TOTAL's, To CLEAR All, 76
- CODE TOTAL's, to View, 72
- CODE TOTAL, To CLEAR, 74
- CODE TOTAL, to View, 71
- Editing, 60
- Introduction, 54
- Memory Sets, 54
- Overflow, 69
- Section, 53
- Setting Flowchart, 55
- To Enter Values, 56
- Using, 66

Comparator:

- Function, 41
- Section, 40
- Setpoints, 41
- To Store Setpoints, 42
- To turn ON & OFF, 45

D

- Digital Clock Option OP-09, 174
- Digital Linearization:
 - Errors, 123
 - Flowchart, 114
 - Procedure, 120
- Digital Tare, 28
- Dimensions, 183

E

- ENTER Key, 9
- Errors:
 - Calibration (C Err 0~8), 119
 - Digital Linearization (C Err 11), 123
 - F-Functions (F Err 1~2), 135
 - Gravity Compensation Func. (C Err 9~10), 128
 - I.D./Tare (no Id), 49
 - TOTAL Overflows (O.F.), 36, 69
- External Displays:
 - AD-8916, AD-8917, AD-8918, 147
- External I/O Connector, 10

F

F-Functions:

- The, 132
 - Changing the, 134
 - Errors, 135
 - F- 1 Decimal Point Adjustment, 136
 - F- 2 Weighing Unit Selection, 136
 - F- 3 Display Update Rate, 136
 - F- 4 Digital Filter, 137
 - F- 5 Set Zero Range, 137
 - F- 6 Motion Detection Condition, 137
 - F- 7 Auto. Zero Track. Comp., 138
 - F- 9 Mode Setting, 138
 - F-11 OP-02 Key Inhibit, 139
 - F-12 OP-02 Comparator Mode, 139
 - F-21 Baud Rate, 139
 - F-22 Output Data, 140
 - F-23 Output Mode, 140
 - F-24 Output Availability, 140
 - F-31 OP-01 Output Data, 141
 - F-32 OP-01 Output Mode, 141
 - F-33 OP-01 Output Logic, 141
 - F-34 OP-01 Output Format, 141
 - F-41 OP-04 Baud Rate, 141
 - F-42 OP-04 Output Data, 141
 - F-43 OP-04 Output Mode, 142
 - F-44 OP-04 Output Availability, 142
 - F-51 OP-07 Analog Output Data, 143
 - F-52 OP-07 Analog Output at Zero, 143
 - F-53 OP-07 Analog Output at Full Scale, 143
 - F-61 OP-08 Printer Output Format, 144
 - F-62 OP-08 Paper Feed after Printing, 144
 - F-63 OP-08 Auto Clear / Printing TOTAL, 145
 - F-64 OP-08 Hour Mode, 145
 - F-71 OP-09 Date Format, 145
 - Flowchart, 133
 - Listed, 14
 - Section, 131
- FCC Rules, v
- Features, 3
- FEED Key, 7
- Flowcharts:
- Calibration, 112
 - Digital Linearization, 114
 - F-Functions, 133
 - Gravity Compensation, 113
- Front Panel, 4
- Display Annunciators, 4
 - Keys, 5
 - Picture, 4
 - Tare Weight Display, 4
 - Unit Annunciators, 5
 - Weight Display, 4
- Full Calibration Procedure, 115
- Fuse, 10

G

- General Rules, 17
- Gravity Compensation Function:
 - Errors, 128
 - Explained, 124
 - Flowchart, 113
 - Gravity values, 129
- GROSS Annunciator, 4

I

- ID/TARE RECALL Key, 6
- ID/TARE STORE Key, 6
- ID/Tare:
 - Error, 49
 - Function, 47
 - to CLEAR, 52
 - To CLEAR All, 52
 - To EXIT from, 49
 - To Store Numbers, 47
 - to View All, 50
 - Weighing, 49
- Installation, 16

K

- Keys, 5
- kg Annunciator, 5

L

- lb Annunciator, 5
- 'lb' or 'kg' Weighing (USA only), 25
- Lb/Kg / 0 Key, 8
- Load Cell:
 - Connection, 18
 - Connector, 10
 - Input Sensitivity, 18

M

- M+ Key, 6
- Main Memory TOTAL:
 - Adding/Subtracting To, 36
 - Function, 29
 - M+, M- and TOTAL Keys, 30
 - Overflow (O.F.), 36
 - to Clear, 38
 - to View, 37
 - To Set Auto Main Mem. Total ADD Mode, 39
- Map of the World, 130
- Maximum Capacity Explained, 110
- MD Annunciator, 4
- Minimum Division Explained, 110
- Mounting Kit, Panel (Option OP-10), 181
- Mounting Kit, Wall (Option OP-11), 182
- M- Key, 7

N

- NET Annunciator, 4
- NET/GROSS Key, 5

O

- Options:
 - OP-01 Parallel BCD Output Connector, 149
 - OP-02 Control I/O Interface, 151
 - OP-04 RS-232C Interface (& Curr. Loop), 152
 - OP-07 Analog Output, 170
 - OP-08 Built-In Printer, 172
 - OP-09 Digital Clock, 174
 - OP-10 Panel Mounting Kit, 181
 - OP-11 Wall Mounting Kit, 182
- OVER Annunciator, 5, 41

P

Panel Mounting Kit (Option OP-10), 181
Parallel BCD Output Connector, 10
Power IN Connector, 10
PRINT Key, 7
PRINTER/2 Key, 8
Printer:
 Auto Print Mode, 83
 Auto M+ Print mode, 89 ; to use, 92
 Changing the Printer Paper, 173
 Code Settings Printout, 95
 Examples, Printout, 97
 Examples, Simple Printing (F-Func. Set.) 78
 I.D./Tare Settings Printout, 94
 M+ Print mode, 85 ; to use, 87
 Printing a CODE TOTAL, 81
 Printing all of the CODE TOTALS, 82
 Printing Items from the Memory, 94
 Printing main memory TOTAL, 80
 Printing the Time, 96
 Printout Examples, 97
 Setting Auto Print mode, 83
 Setting Auto M+ Print mode, 89
 Setting M+ Print mode, 85
 Simple Printing Examples (F-Func. Set.), 78
 Using the Auto M+ Print mode, 92
 Using the Auto M+ Print mode w/ Code, 93
 Using the M+ Print mode, 87
 Using the M+ Print mode with Code, 88

Q

Quick Install, 19

R

Rear Panel Description, 10

S

Serial Interface Connector, 10
Serial Output Connector, 147
SETPOINT/1 Key, 8
Setpoints, 46
Simple Weighing with Tare, 26
Simple Weighing, 25
Span Calibration Explained, 111
Specifications, 11
Standard Serial Output Connector, 10, 147
STANDBY/OPERATE Key, 7
Storing ID/Tare Numbers, 47

T

t Annunciator, 5
TARE Annunciator, 5
TARE Key, 6
Tare Weight Data Display, 4
Tare:
 Digital, 28
 To Clear, 27
 To Weigh With, 26
The Comparator Function, 41
The ID/Tare Function Section, 41
The ID/Tare Function, 47
To Enter Code Set Values, 56

To EXIT from and ID/Tare, 49
To Store ID/Tare, 47
To Store the Comparator Setpoints, 42
To use the Comparator, 41
TOTAL Key, 7
TOTAL:
 ADD Mode, To Set, 39
 M+, M-, 30
 Overflow, 36
 To Clear, 38
 to View, 37
Turning the Comparator ON & OFF, 45

U

UNDER Annunciator, 5, 41
Unit Annunciators, 5
Using CODE TOTAL Memory, 69
Using the Code Function, 66
Using the Gravity Compensation Function, 126

V

Viewing:
 A CODE TOTAL, 71
 All of the Stored ID/Tare's, 50
 All the CODE TOTAL's, 72
 the Main Memory TOTAL, 37

W

Wall Mounting Kit (Option OP-11), 182
Weighing Using Stored ID/Tare, 49
Weight Data Display, 4
Welcome!, 2
World map, 130

Z

ZERO Annunciator, 4
Zero Calibration Explained, 111
ZERO Key, 5



A&D Company, Limited

3-23-14 Higashi-Ikebukuro, Toshima-ku, Tokyo 170 Japan
Telephone: [81] (03) 5391-6132 Fax: [81] (03) 5391-6148 Telex: 2422816 AANDD J

A&D ENGINEERING, INC.

1555 McCandless Drive, Milpitas, CA. 95035 U.S.A.
Telephone: [1] (408) 263-5333 Fax: [1] (408) 263-0119

A&D INSTRUMENTS LTD.

Abingdon Science Park, Abingdon, Oxford OX14 3YS England
Telephone: [44] (0235) 550420 Fax: [44] (0235) 550485

A&D MERCURY PTY. LTD.

32 Dew Street, Thebarton, South Australia 5031 Australia
Telephone: [61] (08) 352-3033 Fax: [61] (08) 352-7409

A&D KOREA Limited

3rd Floor Hanam Bldg 44-27 Yoido-dong Youngdeungpo-ku Seoul, Korea
Telephone: [82] (02) 784-4264 Fax: [82] (02) 784-6557