

Label Printing Scale

DB-300 Series

Owner's Manual

Document No. ELP-301016

Original : **January 2017**
(Revised)

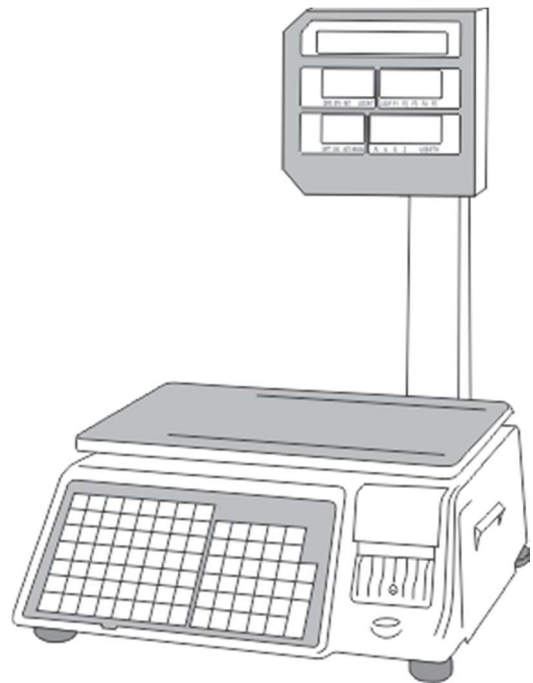

This equipment has been tested and found to comply with the limits for a Class A digital device, pursuant to Part 15 of the FCC Rules. These limits are designed to provide reasonable protection against harmful interference when the equipment is operated in a commercial environment. This equipment generates, uses, and can radiate radio frequency energy and, if not installed and used in accordance with the instruction manual, may cause harmful interference to radio communications. Operations of this equipment in a residential area is likely to cause harmful interference in which case the user will be required to correct the interference at his own expense.





(For USA Only)

Changes or modifications not expressly approved by the manufacturer for compliance could void the user's authority to operate the equipment.

Some procedures described in this manual may be illegal in various state jurisdictions. There are optional settings to enable or to disable various functions. Please ensure that the optional settings for scale operations meet the local requirements of weights and measures. If you are uncertain of specific items, contact the state or county office of weights and measures for clarification.

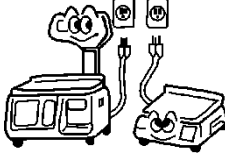
Safety Summary

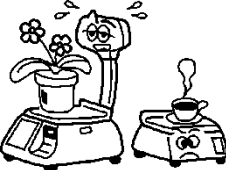
Personal safety in handling or maintaining the equipment is extremely important. Warning and Cautions necessary for safe handling of the equipment are included in this manual. All warnings and cautions contained in this manual should be read and understood before handling or maintaining the equipment. Do not attempt to repair or modify this equipment. If a fault occurs that cannot be corrected using the procedures described in this manual, turn off the power, unplug the equipment, and then contact your service representative for assistance.

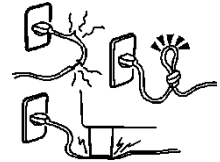
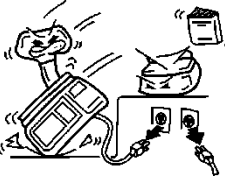
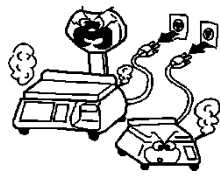
	<p>WARNING <i>This symbol indicates that there is the risk of death or serious personal injury if the machine is improperly handled during this operation or action.</i></p>	
	<p>Do Not Use voltages other than the voltage (AC) specified on the rating plate, as this may cause fire or electric shock.</p>	 <p>Do Not plug in or unplug the power cord plug with we hands as this may cause electric shock.</p>
	<p>If the machines share the same outlet with any other electrical appliances which consume large amounts of power, the voltage will fluctuate widely each time these appliances operate. Be sure to provide an exclusive outlet for the machine as this may cause fire or electric shock.</p>	 <p>Do Not place metal objects or water-filled containers such as flower vases, flower pots or mugs, etc. on top of the machines. If metal objects or spilled liquid enter the machines, this may cause fire or electric shock.</p>
	<p>Do Not insert or drop metal, flammable or other foreign objects into the machines through any openings, as this may cause fire or electric shock.</p>	 <p>Do Not scratch damage or modify the power cords. Also, Do Not place heavy objects on, pull on, or excessively bend the cords, as this may cause fire or electric shock.</p>
	<p>If the machines are dropped or their cabinets are damaged, first turn off the power switch and disconnect the power cord plug from the outlet, then call your Service Representative. Continued use of the machine in a damaged condition may cause fire or electric shock.</p>	 <p>Continued use of the machine in an abnormal condition such as when the machine is producing smoke or strange smells may cause fire or electric shock. In these cases, immediately turn off the power switch and disconnect the power cord plug from the outlet. Then contact your Service Representative.</p>

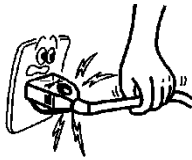
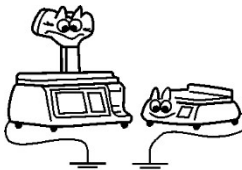
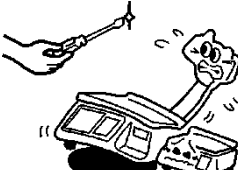
	<p>If foreign objects (metal fragments, water, and liquids) enter the machine, first turn off the power switch and disconnect the power cord from the outlet, and then contact your Service Representative. Continued use of the machine in that condition may cause fire or electric shock.</p>		<p>When unplugging the power cord, be sure to hold and pull on the plug portion. Pulling on the cord portion may cut or expose the internal wires and cause fire or electric shock.</p>
	<p>Ensure that the equipment is properly grounded. Extension cables should also be grounded. Fire or electric shock could occur on improperly grounded equipment.</p>		<p>Do Not remove covers, repair or modify the machine by yourself. You may be injured by high voltage, very hot parts or sharp edges inside the machine.</p>

	<p>CAUTION</p>	<p><i>This symbol indicates that there is risk of personal injury or damage to objects if the machine is improperly handled during this operation or action.</i></p>
---	-----------------------	--

Precautions

The following precautions will help to ensure that this machine will continue to function correctly.

- Try to avoid locations that have the following adverse conditions:
 - Temperatures out of the Specification
 - Direct Sunlight
 - High Humidity
 - Shared Power Source
 - Excessive vibration
 - Dust/Gas
- Do Not subject the machine to sudden shocks.
- Do Not press the keys too hard. Keys will operate correctly if they are touched lightly.
- Clean the cover and keyboard, etc. by wiping with a dry cloth or a cloth soaked with detergent and wrung out thoroughly. Never use thinner or other volatile solvent for cleaning.
- To ensure that the scale is operating correctly, place a known weight on the platter and check it for correct weight measurement. This should be done every morning before starting normal operations.
- When moving the machine, take hold of the case and lift the machine. Never pick up the machine by the remote display unit.
- Do Not place the machine on an unstable or slanted surface as the machine may drop or fall and cause injury.
- Use only **DB Scale** approved thermal paper supplies. Do Not store thermal paper where it may be exposed to direct sunlight, high temperatures, high humidity, dust or gas.
- Ensure that the scale is operated on a level surface.
- Any data stored in the machine may be lost or corrupted during a machine fault. Backup your critical information on a regular basis.
- Try to avoid using the scale on the same power source as high voltage equipment or equipment likely to cause mains interference.
- Unplug the machine whenever you are working inside it or cleaning it.
- Do Not block the ventilation slots of the scale as this will cause overheating which may cause damage to the internal circuit boards or even fire.

Table of Contents

1. INTRODUCTION	1
1.1 Applicable Model (s)	2
1.2 Accessories	2
2. SPECIFICATION.....	3
2.1 Scale Specifications	3
3. APPEARANCE	4
3.1 Scale Dimensions	4
3.2 Label Cassette	5
3.3 Connector Panel.....	5
4. GETTING STARTED	6
4.1 Installing the Scale	6
4.2 Plugging in the Scale	6
4.3 Level Adjustment	7
4.4 Installing the Labels.....	8
4.4.1 Removing Label Cassette	8
4.4.2 Loading the Labels	9
4.5 Turning Power On / Off.....	11
4.5.1 Turning the Power On.....	11
4.5.2 Turning the Power Off.....	11
5. KEYBOARDS	12
5.1 Operations Keyboard	12
5.2 Programming Keyboard	14
6. DISPLAYS AND INDICATORS	17
6.1 Operator and Customer Display	17
6.2 Individual Displays and Tri Mark Indicators.....	18
7. MAIN MENU	19
7.1 Main Menu Modes.....	19
8. BASIC OPERATIONS.....	21
8.1 Setting the ZERO point.....	21
8.2 Recalling a Commodity (PLU).....	21
8.2.1 Using the PLU key	21

8.2.2	Using the SPEED Keys.....	22
8.2.3	Using Automatic PLU Recall	23
8.3	Using Tare Weight.....	24
8.3.1	Registering an Unknown Tare weight.....	24
8.3.2	Registering a Known Tare weight	24
8.3.3	Using a Preset Tare weight	25
8.3.4	Clearing Tare Weights.....	25
8.4	Sales Mode Operations.....	26
8.4.1	Weigh Mode PLU	26
8.4.2	Non Weigh Mode PLU.....	27
8.4.3	By Count Mode PLU	28
8.5	Using the Override Key	29
8.5.1	Weigh Mode Override	29
8.5.2	Non Weigh Mode Override.....	31
8.5.3	By Count Mode Override	32
8.6	Miscellaneous PLU Operations	33
8.6.1	MISC Weigh Mode (without Tare Weight)	33
8.6.2	MISC Weigh Mode (with Tare Weight).....	33
8.6.3	MISC Non Weigh Mode.....	34
8.6.4	MISC By Count Mode	34
8.7	Preset Count Operations.....	35
8.7.1	Preset Count using Non Weight PLU	35
8.7.2	Preset Count using By Count PLU	36
8.8	SAVE Key Operations.....	37
8.8.1	Weigh Mode Operations with SAVE key.....	37
8.8.2	Non Weigh Mode Operations with SAVE key	38
8.8.3	By Count Mode Operations with SAVE Key	39
8.9	PLU Type Change Operations.....	40
9.	Programming (S Mode)	41
9.1	PLU Fields Visible (S0 Mode).....	42
9.1.1	Selecting PLU Fields	43
9.2	PLU File (S1 Mode).....	57
9.2.1	Programming a Weigh Mode PLU (S1 Mode).....	57

9.2.2	Programming a Non Weigh Mode PLU (S1 Mode)	63
9.2.3	Programming a By Count Mode PLU (S1 Mode)	69
9.2.4	Deleting a PLU	75
9.3	Shop Name File (S2 Mode)	76
9.3.1	Entering Shop Name Information	76
9.3.2	Deleting Shop Name Information	78
9.4	Department File (S3 Mode)	79
9.4.1	Entering Department Information	79
9.4.2	Deleting Department Information	81
9.5	Main Group File (S4 Mode)	82
9.5.1	Entering Main Group Information	82
9.5.2	Deleting Main Group Information	84
9.6	PLU Key File (S5 Mode)	85
9.6.1	Programming a Speed Key on Level 1	85
9.6.2	Programming a Speed Key Using Multiple Levels	87
9.7	FUNC Key File (S6 Mode)	90
9.7.1	Assigning Function Keys	90
9.8	Upgrade (S7 Mode)	93
9.9	System Time File (S8 Mode)	95
9.10	Browse System File (S9 Mode)	97
9.11	Browse CAL Record (S10 Mode)	101
9.12	MMX – Discount Rate (S11 Mode)	103
9.12.1	Entering a PLU using Discount Rate	103
9.12.2	Deleting a Discount	106
9.13	MMX –New Price (S12 Mode)	107
9.13.1	Entering a PLU Discount using New Price	107
9.13.2	Deleting a Discount	110
9.14	Clerk Information (S13 Mode)	111

1. INTRODUCTION

Thank you for purchasing the **DB Scale Corporation's** DB-300 Series Label Printing Scale. The DB-300 Series has many features and functions designed for ease of operation and customer satisfaction. We believe that all of your needs will now be fully satisfied. Please read and understand this manual to help obtain maximum performance for this product.

Most queries can be answered from the information contained in this manual. Please keep it in a safe and convenient place for future reference.

Scale Features Overview

- 60 lb Weighing Capacity
- 32 bit ARM Multi Core Processor
- Program and maintain up to 30,000 PLU's
- Time and Date controlled Sales Promotions
- Ethernet Interface is standard (WiFi optional)
- USB Interface (max 8GB) for Backing Up and Restoring data
- File Maintenance can be performed at the Scale or via Software
- Print speeds up to 4ips (100mm)
- Utilizes Label Cassette for quick and convenient label replacement
- Custom Bar Code Formats can be programmed
- Multi language label printing available
- Store up to 50 custom label formats

The list above is just a few of the many features included in the DB-300 Series Label Printing Scale. As you proceed through this manual you will find many more exciting and easy to use functions and features that will help to maintain your pricing integrity.

1.1 Applicable Model (s)

- DB-300-B-60-US
- DB-300-P-60-US

The description of the model number is as follows:

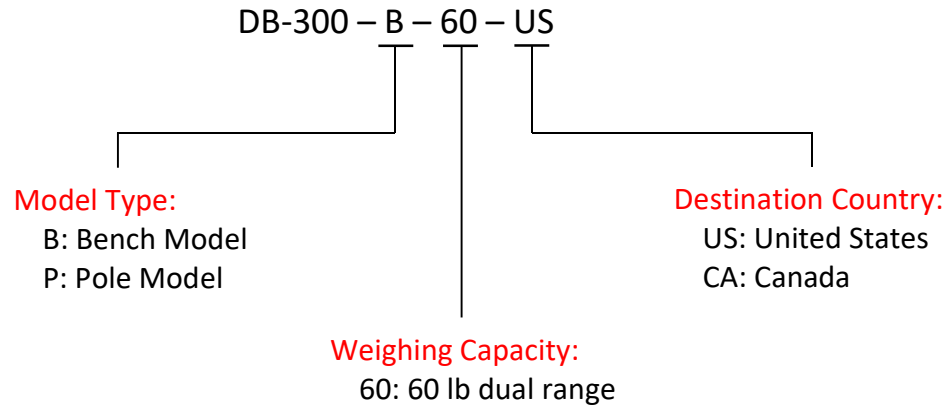

1.2 Accessories

While unpacking the scale, please check to make sure the following accessories are included.



Owner's Manual
(1 Copy)



Display Screws (X4)
TR-4x10

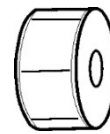

Labels
(1 roll)

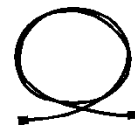

Ethernet Cable
(Crossover)

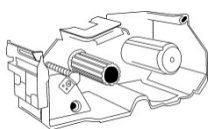

Label Cassette



Sealing Wire

2. SPECIFICATION

2.1 Scale Specifications

Item	60 lb scale (US model)
Maximum Capacity	60 lb
Minimum Scale Division	0.01 lb (0 ~ 30 lb) 0.02 lb (31 ~ 60 lb)
Maximum Tare	2 lbs
Display Range	0 to 60.05 lb
Unit Price Pre-settable	\$ 0.01 to \$ 99.99
Minimum Price Display	\$ 0.01
Display	Operator and Customer
	LED (White on Blue)
	Weight 5 digits, Unit Price 6 digits,
	Tare Weight 4 digits, Total Price 7 digits
Keyboard	Operation and Built In Programming
	Operation – 34 Function Keys
	Speed Key - 168 Keys (56 x 3 Levels)
Capacity of PLU Memory	30,000 PLU's
Print Head Type	Thermal Print Head
Issue Method	Strip, Receipt
Dot Density	202 Dots per inch (8dots/mm)
Print Speed	4 IPS (100mm/sec)
Available Media Width	40mm to 60mm (including backing paper)
Interface	LAN, Wireless LAN
Dimensions (approx.)	17.7 inches (W) x 18.4 inches (D) x 6.1 inches (H)
Weight	36.6 lb (16.6 kg)
Power Requirement	AC 85V to 138V, 50/60 Hz ±2%
Power Consumption	90W/1.5A (when printing) 40W/0.6A (Stand by)
Temperature Limits	23°F to 95°F (-5°C to +35°C)
Relative Humidity	30% to 80% (No condensation)

3.1 Scale Dimensions

3. APPEARANCE

3.1 Scale Dimensions

Pole Model

Units: Inches (mm)

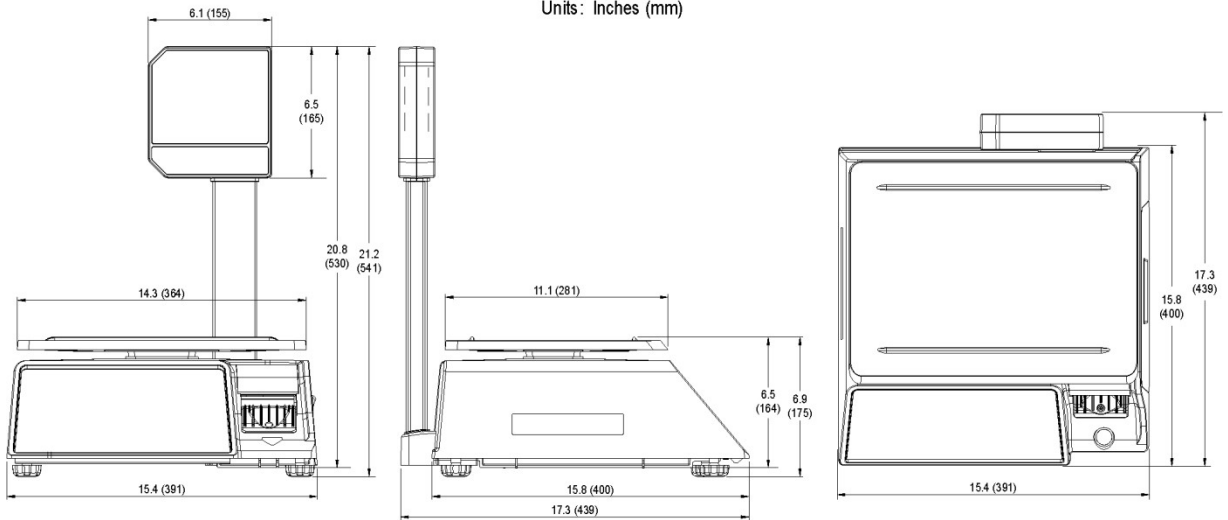

3.2 Label Cassette

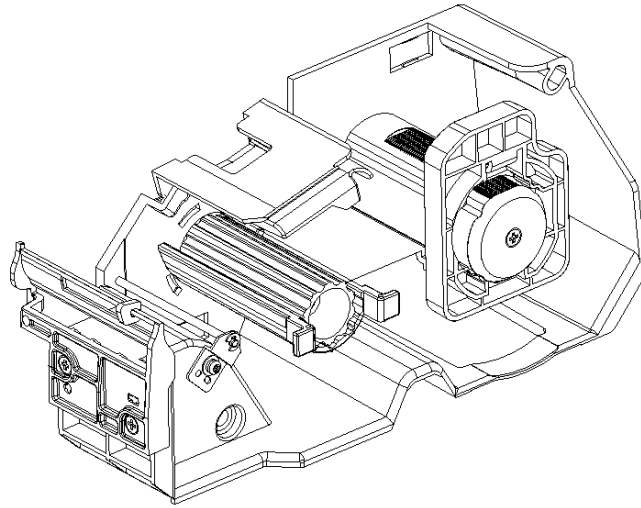

3.3 Connector Panel

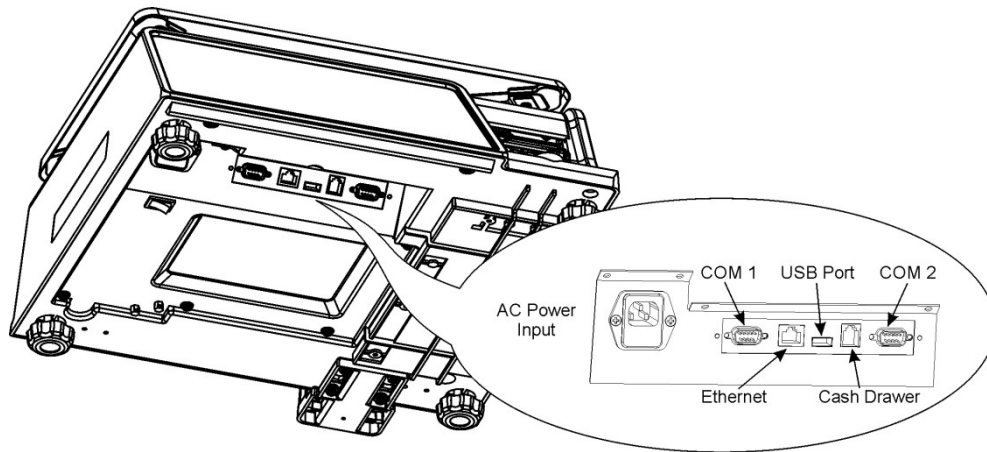

4. GETTING STARTED

4.1 Installing the Scale

The scale should be installed on a sturdy level surface with an adequate ventilation area around it. There should also be enough area around the scale to allow for easy operation of the scale, meaning room to change label rolls when necessary, etc. Failure to do so will decrease the overall operational efficiency of the scale.

	CAUTION	<i>This symbol indicates that there is risk of personal injury or damage to objects if the machine is improperly handled during this operation or action.</i>
---	----------------	---

When installing the scale avoid locations that place the scale in areas of:

- direct sunlight
- vibration
- moisture
- wind
- temperatures outside of the specifications
- rapid temperature changes
- devices that produce electrical interference
- high humidity
- open flame
- dust

Failure to follow these suggestions may result in incorrect operation of the scale.

	WARNING	<i>This symbol indicates that there is risk of personal injury or damage to objects if the machine is improperly handled during this operation or action.</i>
---	----------------	---

4.2 Plugging in the Scale

- Only insert the plug into a properly rated outlet.
- Do Not plug the scale into an outlet with other electrical appliances. Other electrical appliances may consume a large amount of power when operating which may affect the scale's operation.
- Do Not use an extension cord.
- Do Not insert or remove the plug with wet hands.
- Do Not excessively bend, pull on, damage, place a heavy object on or heat the power cord.
- Make sure to fully insert the plug into the AC outlet.
- Make sure to only hold and pull on the plug when inserting or removing the power cord. Pulling on the cord instead of the plug may bread the wires internally causing a fire or shock hazard.
- Make sure the scale power is off prior to inserting the plug. Failure to do so may result in a short circuit and machine failure.

4.3 Level Adjustment

	<h2>CAUTION</h2>	<p><i>This symbol indicates that there is risk of personal injury or damage to objects if the machine is improperly handled during this operation or action.</i></p>
---	------------------	--

- **Use care when adjusting the scale legs to prevent squashing the power cord. Damaging the power cord could cause fire or electrical shock.**
- **To prevent the level adjustment from being changed accidentally, secure the adjustable legs with the locking nut after leveling.**

4.3 Level Adjustment

For correct weighing operations the scale should be leveled prior to use. Turn the four adjustable legs so that the bubble in the level gauge is positioned inside the center circle. Then secure the locking nut.

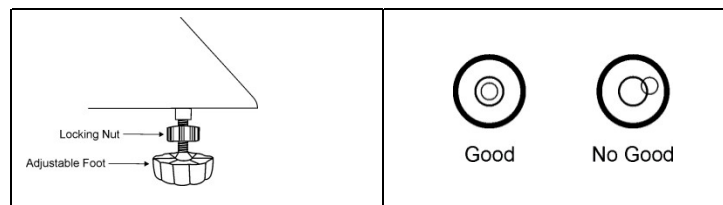
**When the Level Bubble is to the RIGHT.**

Turn the Left Side Adjustable Legs Clockwise, or turn the Right Side Adjustable Legs Counterclockwise.

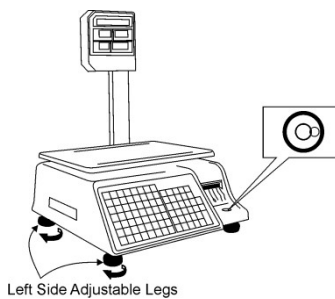
**When the Level Bubble is to the LEFT.**

Turn the Right Side Adjustable Legs Clockwise, or turn the Left Side Adjustable Legs Counterclockwise.

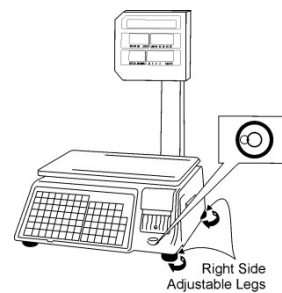
**When the Level Bubble is to the BACK.**

Turn the Front Side Adjustable Legs Clockwise, or turn the Rear Adjustable Legs Counterclockwise.

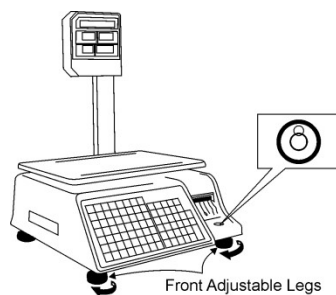
**When the Level Bubble is to the FRONT.**

Turn the Rear Adjustable Legs Clockwise, or turn the Front Side Adjustable Legs Counterclockwise.

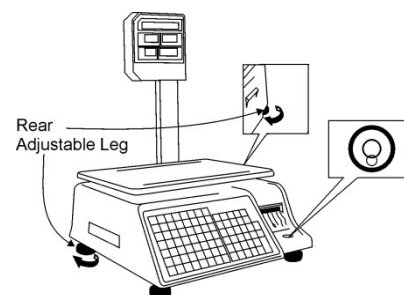

4.4 Installing the Labels

4.4.1 Removing Label Cassette

1. Open Side Door and Open the Print Head.

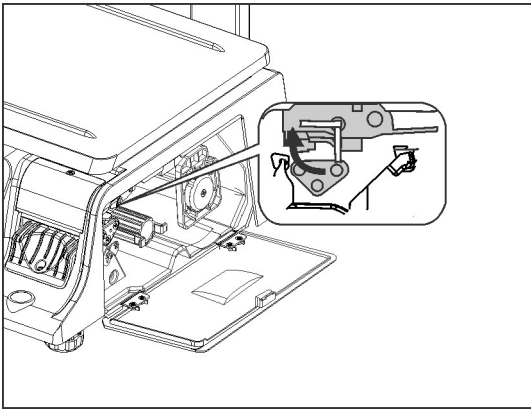

2. Slide Label Cassette Out of Scale.

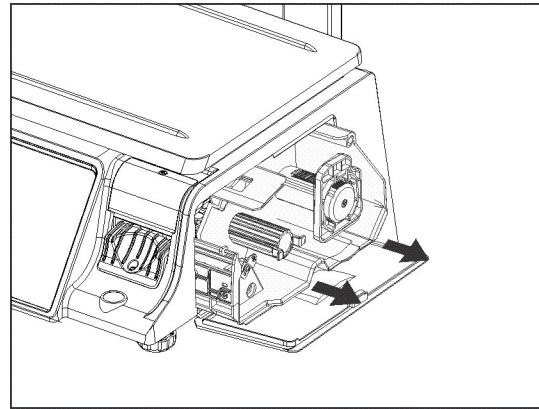

3. Label Cassette (Complete)

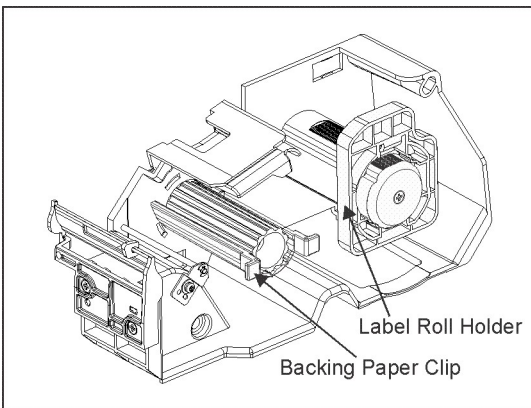

4. Turn Label Roll Holder counterclockwise 90 degrees.

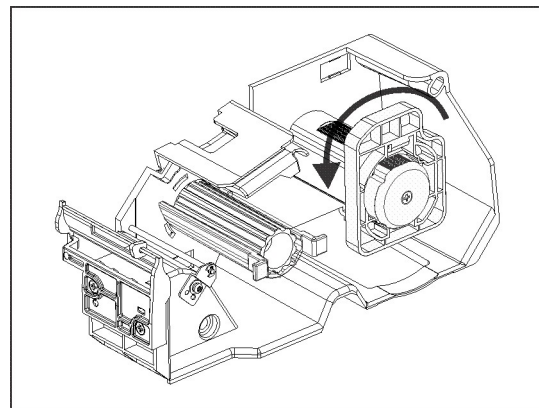

5. Label Roll Holder rotated 90 degrees.

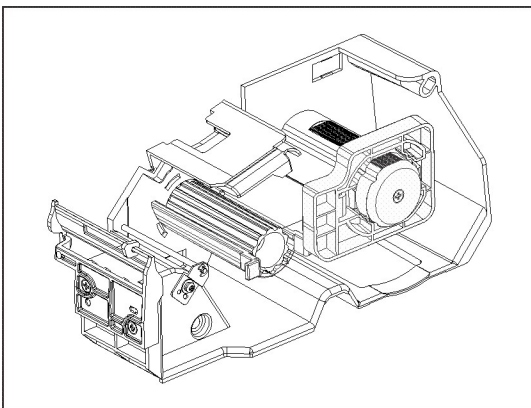

6. Remove Label Roll Holder and the Backing Paper Clip by pulling them in the direction of the arrows.

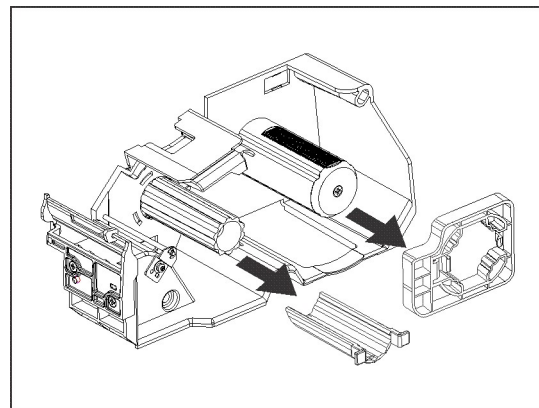

4.4 Installing the Labels

4.4.2 Loading the Labels

1. Empty Label Cassette (Complete)

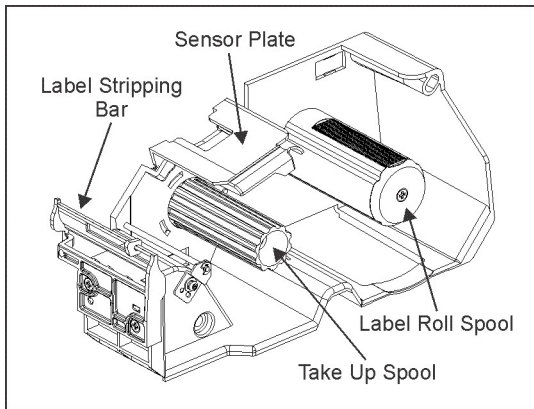

2. Place the Roll of Labels on the Label Roll Spool.

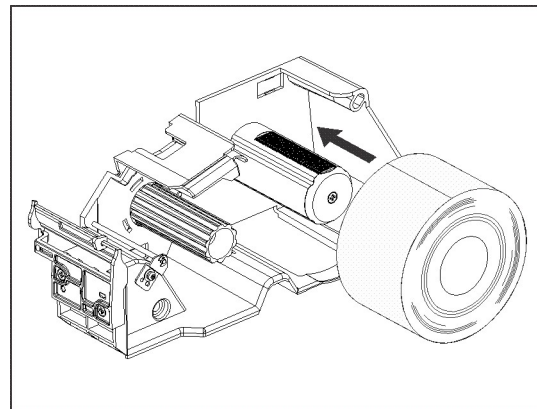

3. Thread the Backing Paper Portion of the roll of labels through the Sensor Plate.

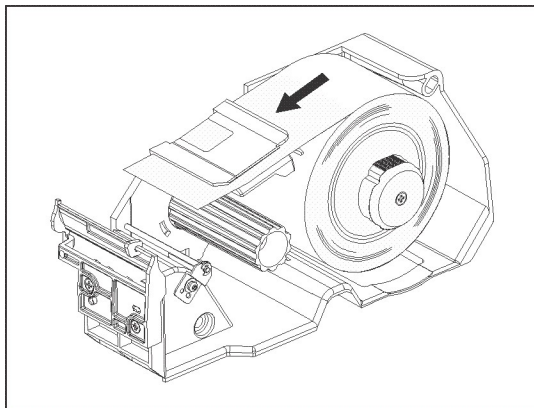

4. Continue threading the backing paper over the Label Stripping Bar and under the Take Up Spool.

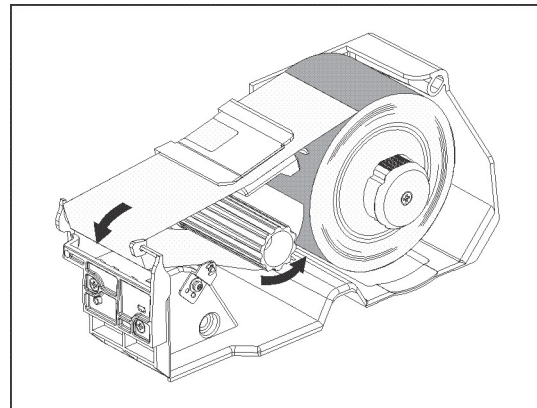

5. While holding the backing paper around the Take Up Spool, snap the Backing Paper Clip in place.

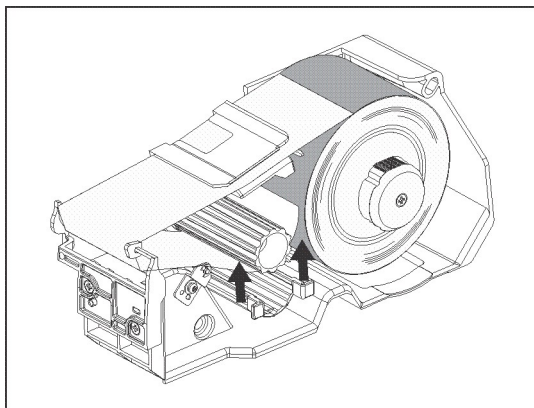

6. The Backing Paper Clip should be secured in place.

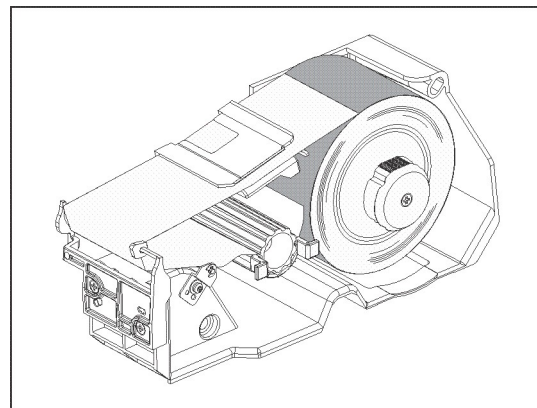

4.4 Installing the Labels

7. Place the Label Roll Holder on the Label Roll Spool as shown below.

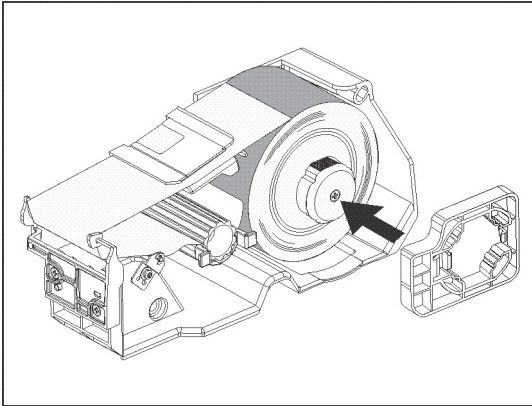

8. Rotate the Label Roll Holder clockwise 90 degrees until it locks in place.

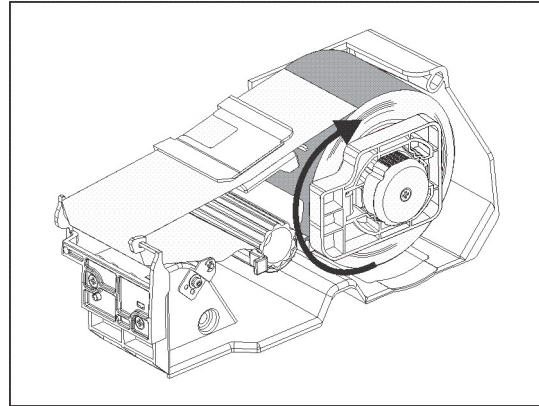

9. The Label Roll Holder should be secured in place.

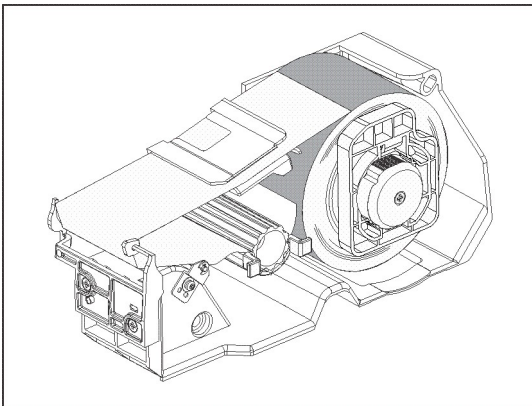

10. Turn the Backing Paper Spool with Clip counter clockwise to advance the labels as shown below.

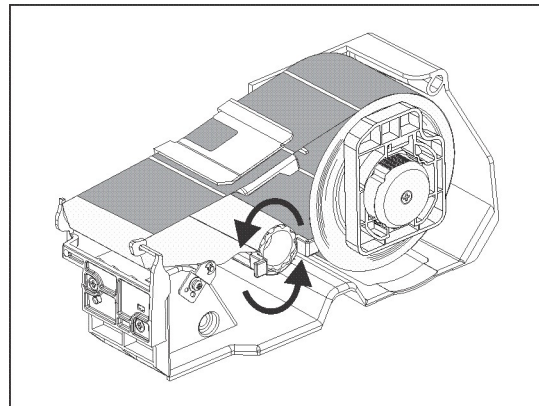

11. Install the Label Cassette with labels into the scale.

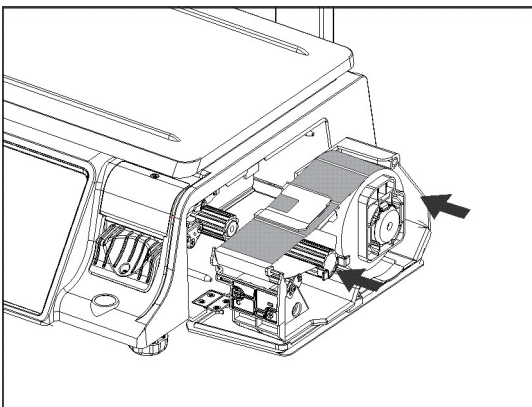

12. Close the Print Head. Close the Side Door. Press the Esc/Feed key one time.

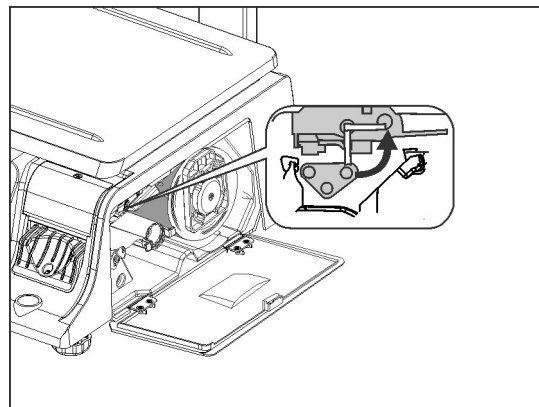

4.5 Turning Power On / Off

4.5.1 Turning the Power On

1. Make sure that the power plug is fully inserted into the AC outlet.
2. Make sure that nothing is located on the scale platter.
3. Turn the power switch to the ON (1) position.

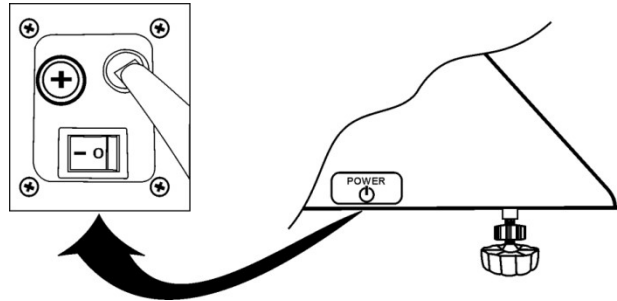

4.5.2 Turning the Power Off

1. Do Not turn Off the power during printing
2. Do Not turn Off the power in the middle of an operation.
3. Turn the power switch to the OFF (0) position.

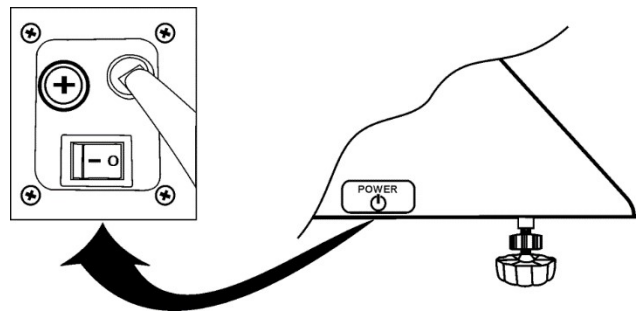

5.1 Operations Keyboard

5. KEYBOARDS

5.1 Operations Keyboard



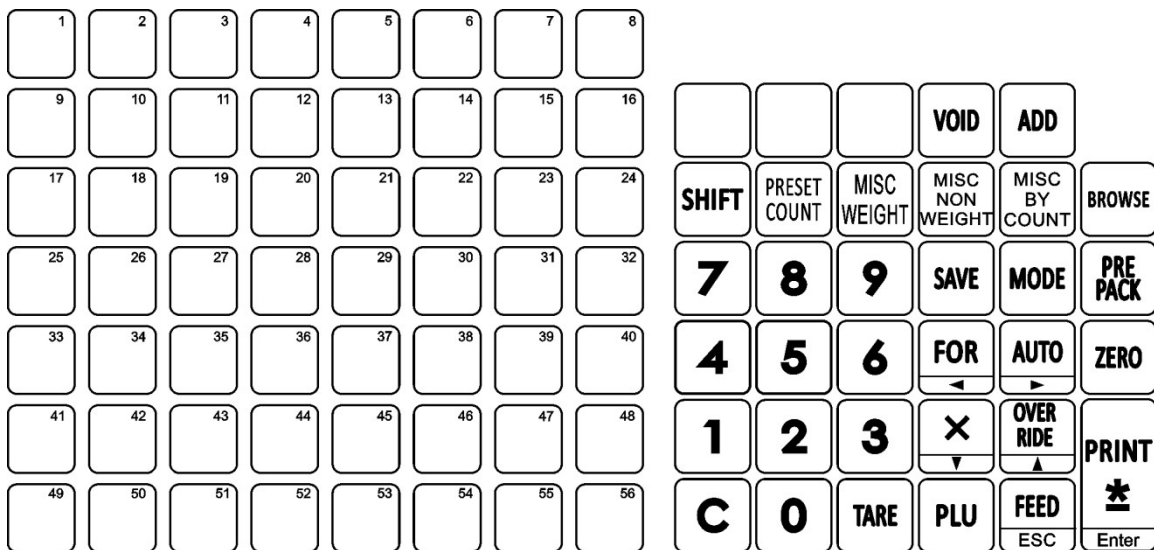











The Operations Keyboard consists of 56 (x3 levels) Speed Keys and 34 Function Keys. All of the key functions are explained below.



Several keys have multiple purposes; please refer to the appropriate keyboard section for the correct key function explanation.

Key	Function
	Keys numbered 1 to 56 (3 levels) can be used for quick recall of PLU's or may be programmed as a special function key.
	Used to Void or remove an item from an accumulated/sum transaction.
	Used to Add an item to the accumulated/sum transaction. Used to issue a label in the accumulation/sum mode.
	Used to access Level 2 and Level 3 of the Speed Keys.
	Used to enter a known quantity of labels to be issued for a Non Weight or By Count type PLU.
	Used to conduct a transaction for a Weight item that is not programmed in the scale's memory.
	Used to conduct a transaction for a Non Weight item that is not programmed in the scale's memory.

5.1 Operations Keyboard

Key	Function
	Used to conduct a transaction for a By Count item that is not programmed in the scale's memory.
	Used to save the Unit Price and Tare Weight of a recalled commodity for use in multiple transactions.
	Used to browse through the PLU file. Also used to step through the communications setup. (based on scale model)
	Used to place the scale in the Prepack mode for backroom operations.
	Used to enter the quantity of a commodity in Non Weight or By Count modes of operation. Used to change the PLU Type of a Weigh Mode PLU. Left arrow key is not used.
	Used to place the scale in the Automatic Print mode. Right arrow key is not used.
	Used to reset the Zero reference count of the scale.
	The X key is not used in the operations mode.
	Used to implement Unit Price, Tare Weight or Quantity changes in a recalled commodity. May be password protected.
	Used to clear keyboard input errors.
	Used to manually enter a Tare Weight for a commodity.
	Used to recall a programmed commodity.
	Used to issue a blank label. The ESC function is not used in the operation mode.
	Used to manually print a label. The Enter function is not used in the operation mode.

5.2 Programming Keyboard

5.2 Programming Keyboard



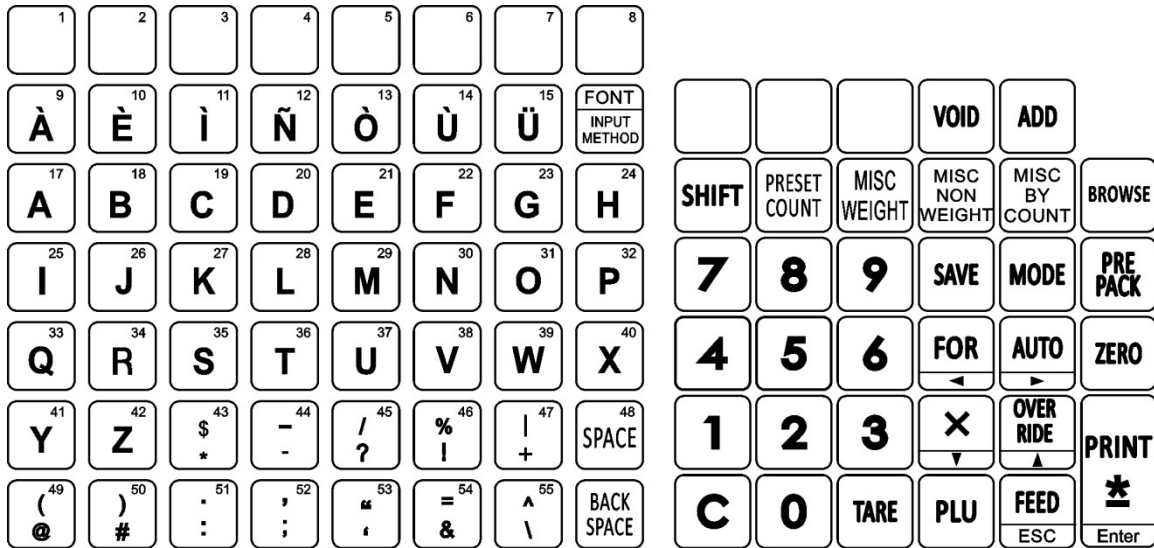

The built in programming keyboard consists of the letter and symbol keys as well as some of the Operations keyboard function keys.



Several keys have multiple purposes; please refer to the appropriate keyboard section for the correct key function explanation.

Key	Function
	Used to enter text and symbols.
	Used to change the text input method from the built in keyboard characters to Unicode. Changes Font Size in text fields.
	Used to insert a character space when entering text.
	Used to move the cursor back one space and delete any character in that space while editing text.
	Used to access lower case letters and symbols. Acts like a shift lock key.
	Used to access the different programming modes.
	Left arrow key used to navigate and move the cursor while editing text fields. FOR has no function in programming modes.
	Right arrow key is used to navigate and move the cursor while editing text fields. AUTO has no function in programming modes.

5.2 Programming Keyboard

Key	Function
	Used to change lines downwards when programming text fields with multiple lines available. Also used to navigate downwards through certain programs.
	Used to change lines upwards when programming text fields with multiple lines available. Also used to navigate upwards through certain programs.
	Used to delete items from memory.
	Feed function not used in program mode. ESC is used to move up or back one level and to exit a program mode.
	Print function is not used in program mode. Enter is used to enter or store information.

5.2 Programming Keyboard

6.1 Operator and Customer Display

6. DISPLAYS AND INDICATORS

6.1 Operator and Customer Display

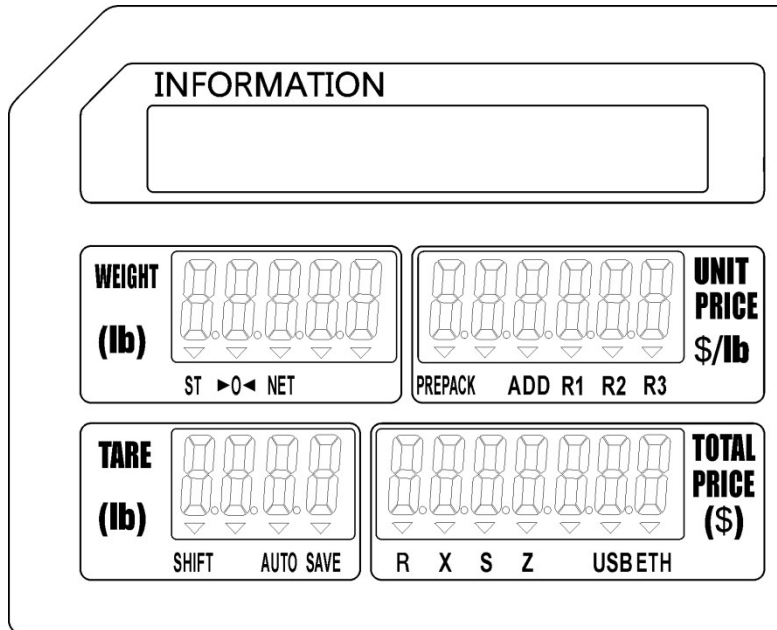

Operator Display

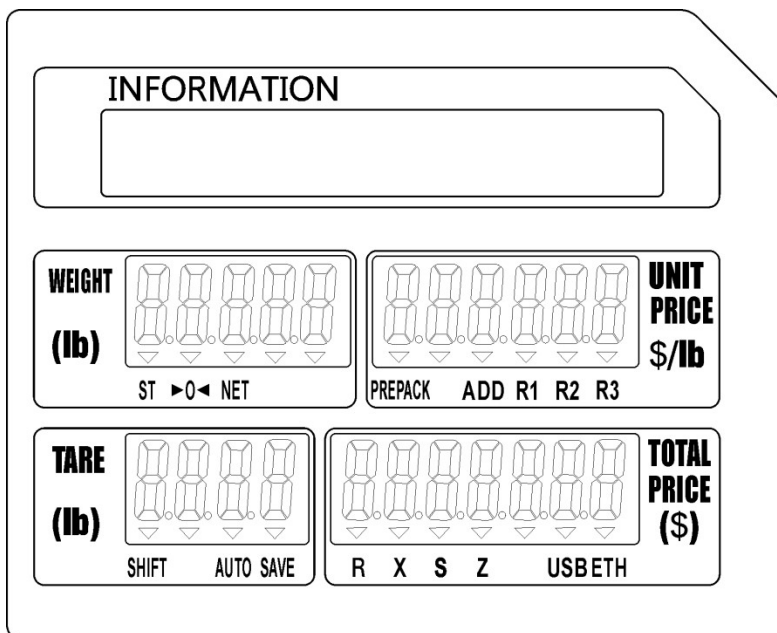

Customer Display

6.2 Individual Displays and Tri Mark Indicators
6.2 Individual Displays and Tri Mark Indicators

Display	Information
INFORMATION	Displays the Commodity Name. Displays Menu Titles.
WEIGHT	Displays up to 5 digits of Weight information.
UNIT PRICE	Displays Unit Price up to 5 digits or Pieces count of recalled Commodity.
TARE WEIGHT	Displays up to 4 digits of Tare Weight information. Displays Program Mode steps.
TOTAL PRICE	Displays up to 7 digits of Total Price information. Displays Program Mode text.

Indicator	Function
▼ ST	Indicates the platter is in a stable condition
▼ 	Indicates that no Tare weight has been set and nothing has been placed on the platter.
▼ NET	Indicates a Tare weight has been entered and that the displayed weight will be a net weight.
▼ PREPACK	Indicates the scale has been placed in the PrePack mode of operation.
▼ ADD	Indicates the scale is in the Accumulation or SUM mode of operation.
▼ R1	Indicates the transaction is in Override position one.
▼ R2	Indicates the transaction is in Override position two.
▼ R3	Indicates the transaction is in Override position three.
▼ SHIFT	Indicates the Shift key has been depressed.
▼ AUTO	Indicates the Automatic Print Mode is enabled.
▼ SAVE	Indicates the Unit Price and Tare Weight will not be cleared automatically.
▼ R	Indicates the scale is in the R mode of operation. This is normal weigh mode.
▼ X	Indicates the scale is in the X mode of operation. This is the sales report mode.
▼ S	Indicates the scale is in the S mode of operation. This is the main programming mode.
▼ Z	Indicates the scale is in the Z mode of operation. This is the reset mode.
▼ USB	Indicates a USB device has been inserted and detected.
▼ ETH	Indicates the scale is using Ethernet mode communications.

7. MAIN MENU

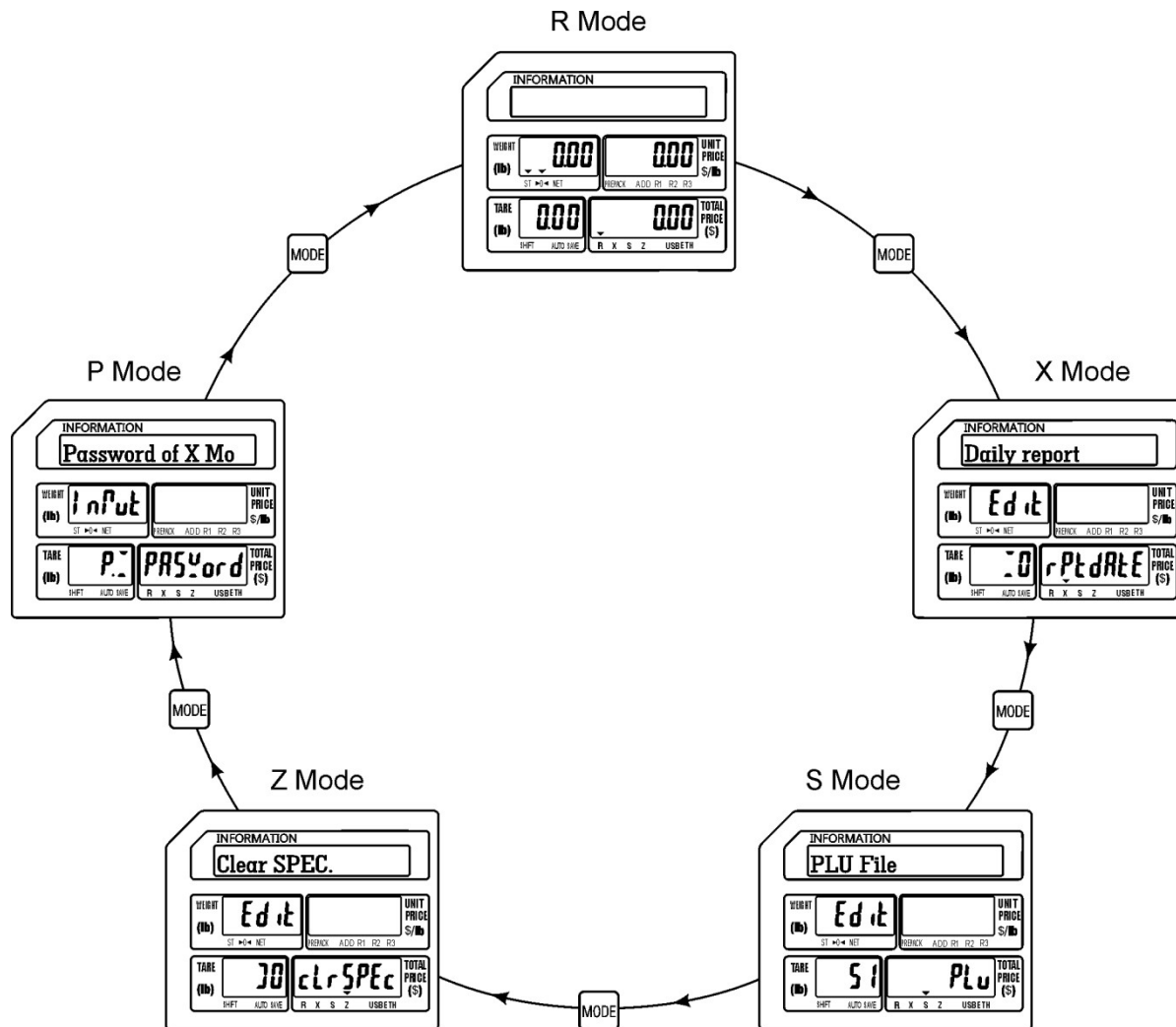

7.1 Main Menu Modes

R Mode

The R mode is used to perform most daily operations such as weighing commodities, recalling programmed commodities and issuing labels. After normal power on procedures the scale will be in the R mode. All transactions performed in this mode are recorded and saved in memory for use by management for Sales Reports.

X Mode

Pressing the MODE key once will take you to the X mode. The X mode is used to perform Sales Reports using information obtained during normal daily operations of the scale. Several types of reports are available in the X mode. There are both daily and monthly reports available. Some report categories available are By PLU, By Department and By Group. Some other special functions available are Exporting Sales Data and printing a PLU List. For a detailed explanation of these functions please refer to the appropriate section(s) of this manual.

S Mode

Pressing the MODE key twice will take you to the S mode. The S mode is where most of the programmed information used during daily operations is directly entered at the scale. *(The same information may also be entered using the XDB Manager Software program where available.)* There are several programming items available, from selecting which information fields are visible when programming a commodity or PLU to programming date and time controlled discount sales. Each of the many functions is explained in the S mode (Programming Mode) section of this manual.

Z Mode

Pressing the MODE key three times will take you to the Z mode. The Z mode is mainly used to reset information in the scale back to a factory default configuration or clearing the programmed information out of memory. Most types of programmed information may be conveniently reset or cleared individually. Stored Sales Information can also be reset/cleared using the Z mode. There are several other special functions available in the Z mode such as compressing and recreating the commodity database, printing the system activity log, printing the firmware upgrade information, printing the scale calibration record and backing up and restoring programmed information.

P Mode

If the P mode has been enabled in the SPEC program, pressing the MODE key four times will take you to the P mode. The P mode is used to provide some level of security when accessing or programming information in the scale. It is not normally visible in the Main Menu list and must be enabled using the SPEC configuration mode. When enabled and configured correctly a password will be required to access the X, S and Z modes in the scale.

8. BASIC OPERATIONS

In this section, basic R mode operations such as recalling a commodity, entering a tare weight, weighing and issuing labels, etc. are explained.

8.1 Setting the ZERO point

The ZERO key may be used to make corrections for minor deviations in the zero reference point. The scale may drift from zero due to environmental conditions, debris on the platter or leaving objects on the platter for long periods of time. To correct this, remove all objects and debris from the platter. When the ST tri-mark (▼) is lit, press the ZERO key.

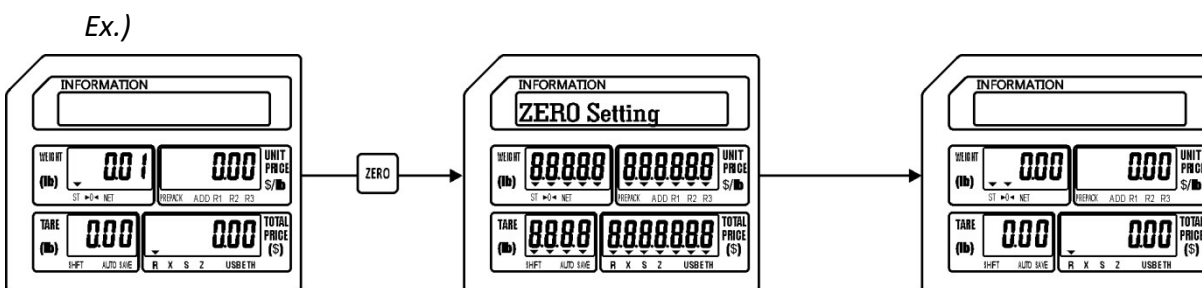

The scale Weight display should now show zero. If the scale will not return to Zero, contact your authorized service representative.

8.2 Recalling a Commodity (PLU)

There are three methods of recalling a commodity or PLU. These methods are used to recall Weigh, Non-Weigh and By Count mode commodities (PLU's). The procedure is the same for all of the PLU types.

8.2.1 Using the PLU key

To recall a PLU from memory input the PLU number using the numeric keys and then press the PLU key.

Ex.) Recall PLU #12

Action: Enter 12 using the numeric keypad, then press the PLU key.

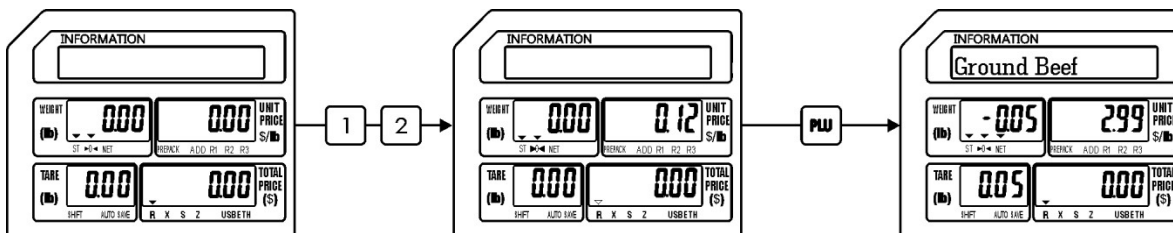

8.2.2 Using the SPEED Keys

8.2.2 Using the SPEED Keys

To recall a PLU using the pre-programmed Speed Keys, simply press the Speed Key with the desired PLU number assigned to it. Please note that when using multiple Speed Key levels the operation is affected by the setting of SPEC 073 (Combination Recall)

Ex.) Recall PLU #12 assigned to Speed Key 4 on level 1. (SPEC 073 = 0 or 1)

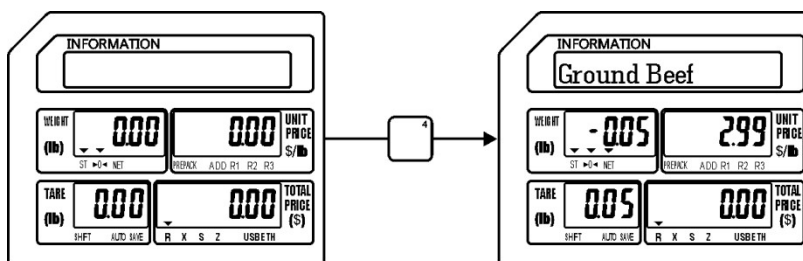

Ex.) Recall PLU #18 assigned to Speed Key 4 on level 2. (SPEC 073 = 0)

Action: Press Speed Key #4 twice (within 1 second) to recall the PLU on level 2.

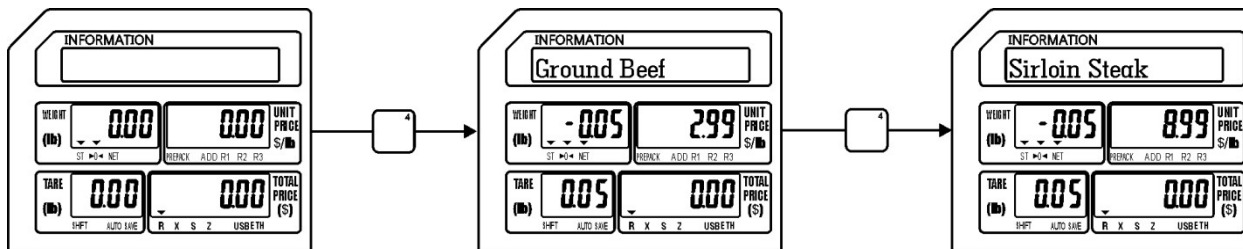

Ex.) Recall PLU #18 assigned to Speed Key 4 on level 2. (SPEC 073 = 1)

Action: Press the level number desired (level 2) using the numeric keypad, then press the Speed Key desired (#4).

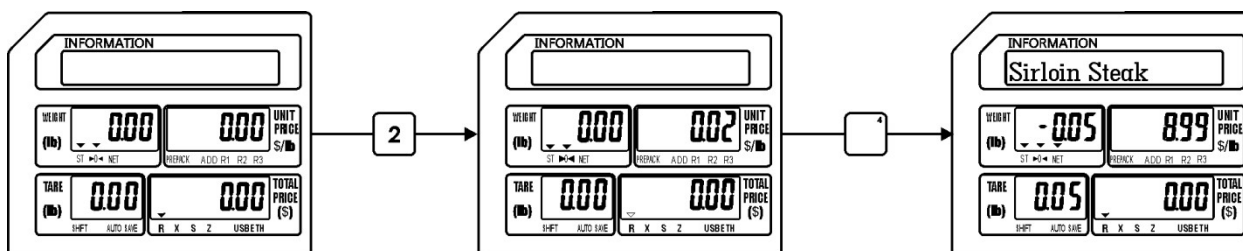

8.2.3 Using Automatic PLU Recall

8.2.3 Using Automatic PLU Recall

Recalling a PLU automatically requires that the automatic recall function in the SPEC program be enabled. (SPEC #071) When the function is enabled, you recall a PLU by entering the PLU number using the numeric keys. After the last number of the PLU is entered, there will be a slight delay (about 3 seconds) and then the PLU will be recalled automatically.

Ex.) Recall PLU #12

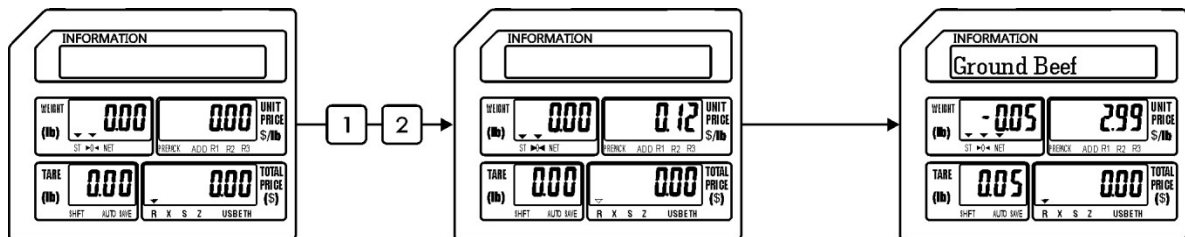

8.3.3 Using a Preset Tare Weight

8.3 Using Tare Weight

There are three different types of Tare weight, a known Tare weight, an unknown Tare weight and a Preset Tare weight. The procedures to use and clear all three types are explained below.

- Notes:**
1. The NET Tri-mark (▼) will be lit whenever there is any Tare weight used.
 2. To clear the Tare weight before weighing a PLU, remove the container from the platter and then touch the Tare key.
 3. The Tare weight will automatically be cleared after the transaction is complete.
 4. Touching the Save key while a Tare weight is present will retain the Tare weight even after the commodity has been removed from the platter.

8.3.1 Registering an Unknown Tare weight

An unknown Tare weight may be entered by placing the container on the platter and pressing the Tare key. After the Tare key has been pressed the Tare weight will be displayed in the Tare display window and the NET tri-mark (▼) will be lit.

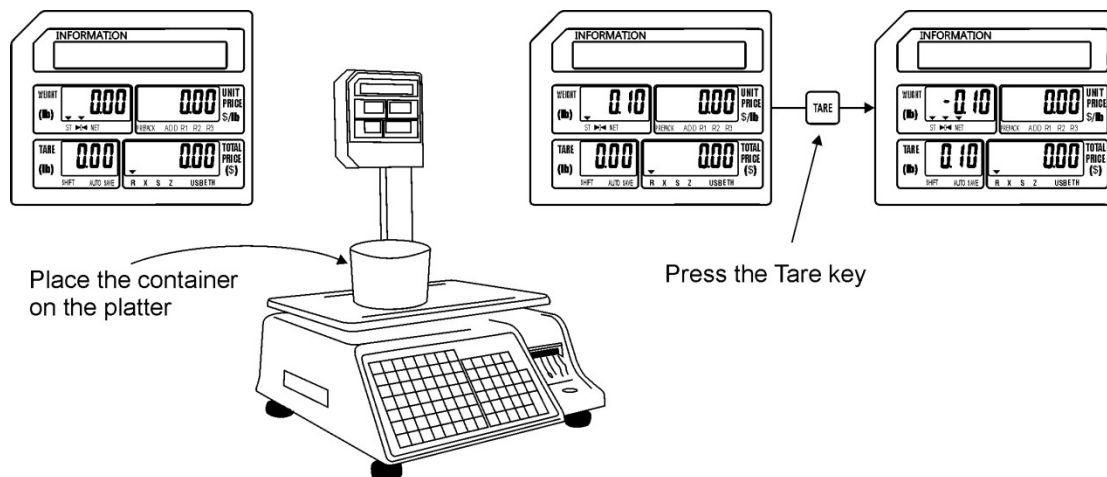

8.3.2 Registering a Known Tare weight

A known Tare weight may be entered using the numeric keys. Enter the Tare weight value using the numeric keys and then press the Tare key. After the Tare key has been depressed, the Tare weight will be displayed in the Tare display window and the Net tri-mark (▼) will be lit.

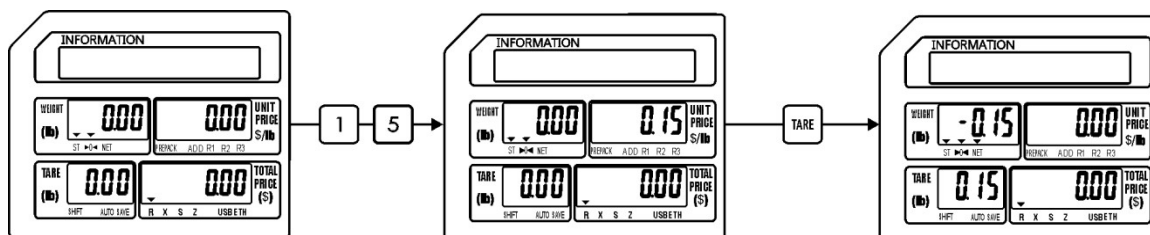

8.3.3 Using a Preset Tare Weight

8.3.3 Using a Preset Tare weight

Using a Preset Tare weight is accomplished by pre-programming the Tare weight for the PLU during the PLU programming steps (refer to S Mode - S1 PLU File). When the PLU is recalled, the Preset Tare weight is recalled with the PLU.

Ex.) Recall PLU #18 which has a Preset Tare weight of 0.10 lbs.

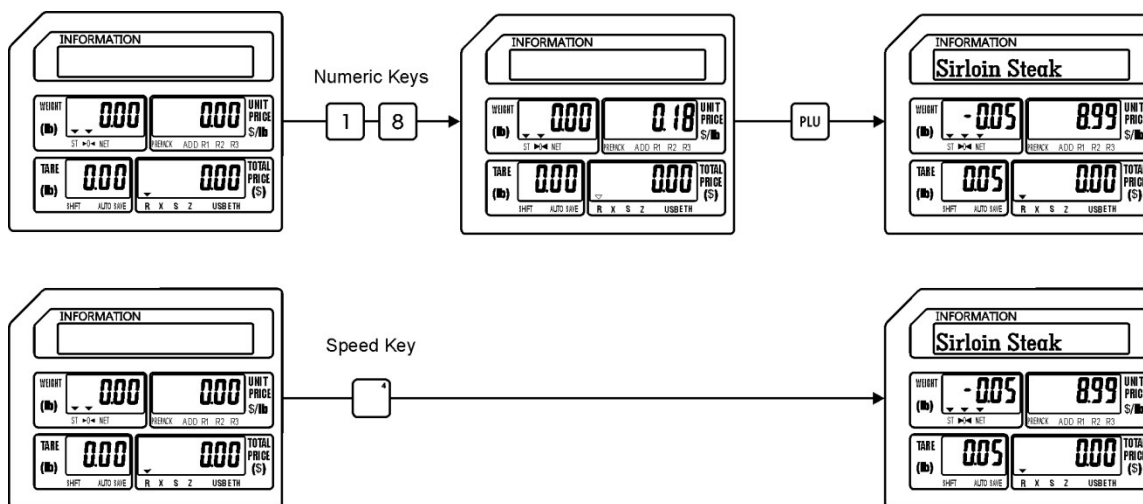

8.3.4 Clearing Tare Weights

All types of Tare weight will normally be cleared automatically upon completion of a transaction. The only time this will not happen is if the Save key has been depressed before the transaction or the scale is in the Prepack Mode of operation.

Note: *The completion of a transaction is defined as the weighing of the commodity, the issuing of the label and the removal of the commodity from the platter and the label from the printer.*

To manually clear a Tare weight before a transaction, simply remove the container (tare weight) and press the Tare key.

8.4 Sales Mode Operations

The procedures in the next sections explain the three normal modes of operation in the scale. They are the Weigh Mode, Non Weigh Mode and the By Count Mode. Each mode has a specific procedure that should be followed to ensure proper operation of the scale.

8.4.1 Weigh Mode PLU

The Weigh Mode is used to weigh an item for sale. An item that is to be weighed may have a Tare Weight associated with it. (refer to Section 8.3 Using Tare Weight)

Ex.) Recall the PLU for Ground Beef (PLU #12) which is sold by weight at \$2.99 per pound. The PLU has a Preset Tare Weight of -0.05lbs.

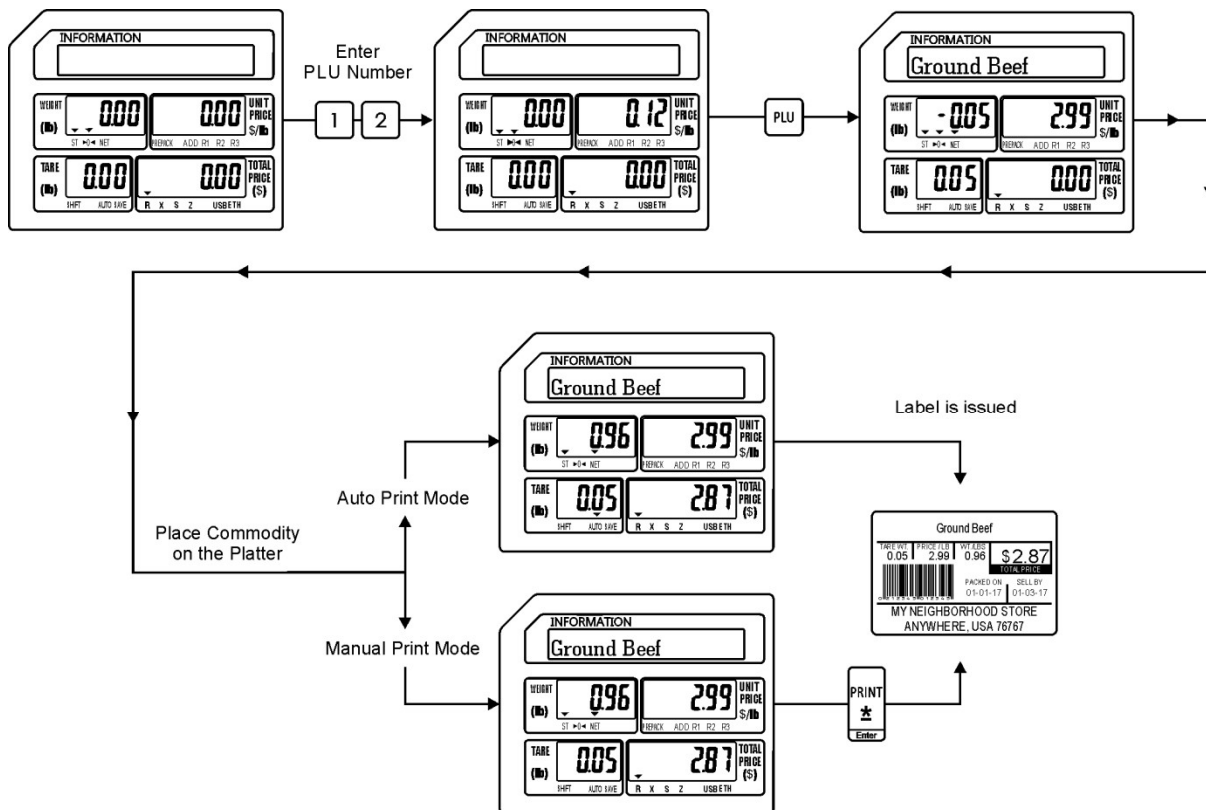

Note: To use the AUTO Print Mode it must be enabled prior to recalling the PLU. To enable the AUTO Print Mode simply press the AUTO key on the Operations keyboard. When the AUTO Print Mode is enabled the AUTO tri-mark will be lit.

8.4.2 Non Weigh Mode Operations

8.4.2 Non Weigh Mode PLU

The Non Weigh Mode is used to issue a label for an item that isn't sold by weight. Usually Non Weigh Mode items are sold by pieces with a certain value placed on each piece. In the example below the Non Weigh item is Apples.

Ex.) Recall PLU#15 for Apples which is sold by the piece at a price of \$0.29 each.

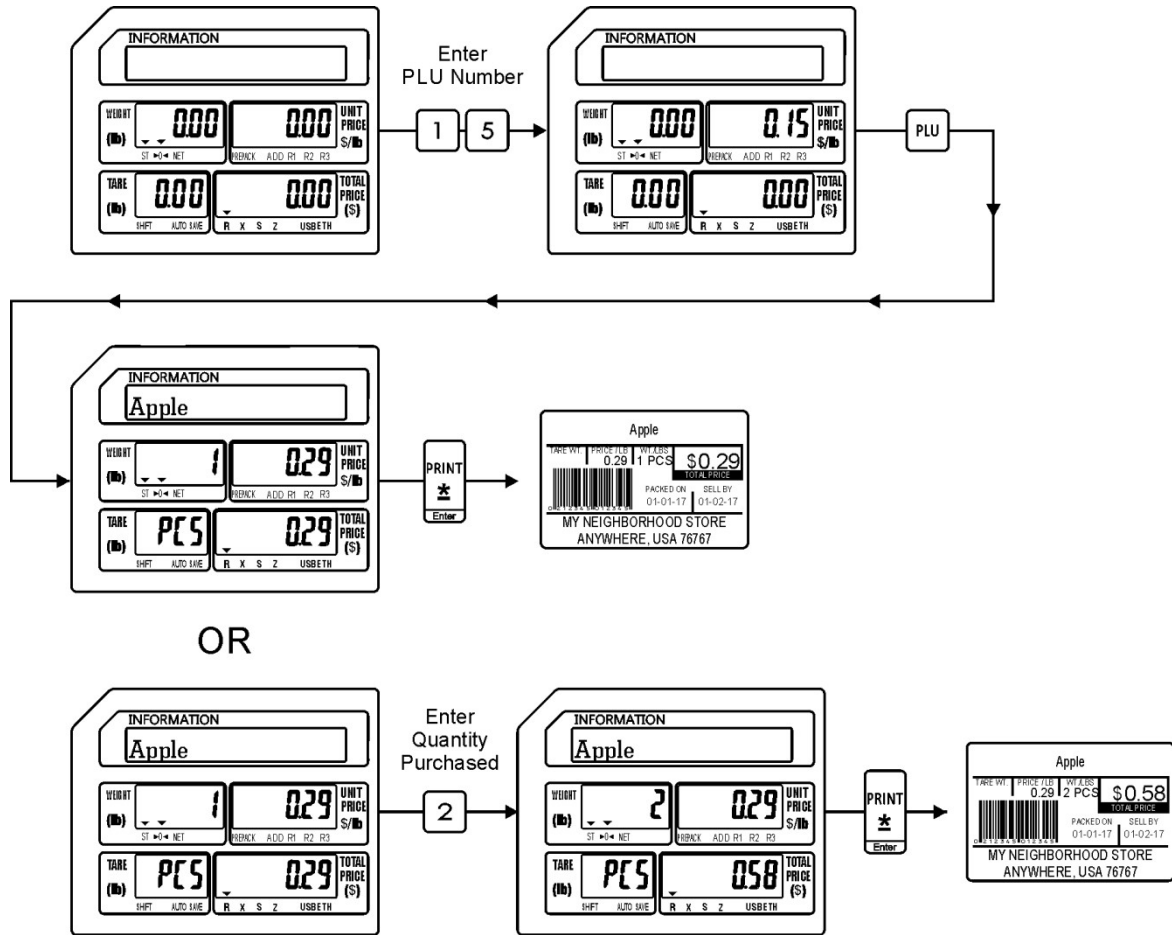

Note: There is no difference between the AUTO Print Mode and the Manual Print Mode in the Non Weigh Mode operation. In the example there are two methods, one shows the procedure used to sell a single item and the second shows the procedure to sell multiple items at the same time to a customer.

8.4.3 By Count Mode Operations

8.4.3 By Count Mode PLU

A By Count Mode PLU is an item that is similar to a Non Weigh Mode item because it is also sold by pieces and not weight. The difference between the two modes is that the By Count Item is usually sold or packaged in multiple pieces for a price. The By Count Mode operation allows you to sell the whole packaged item or split the item and sell it based on a per piece value.

Ex.) A customer is purchasing bananas that are priced at 3 for \$1.00 and they are purchasing 3 bananas. In the second part of the example the customer is purchasing the same bananas priced at 3 for \$1.00 but they only want to purchase 2 bananas instead of 3. The By Count Mode allows you to split the item by simply entering the quantity purchased by the customer.

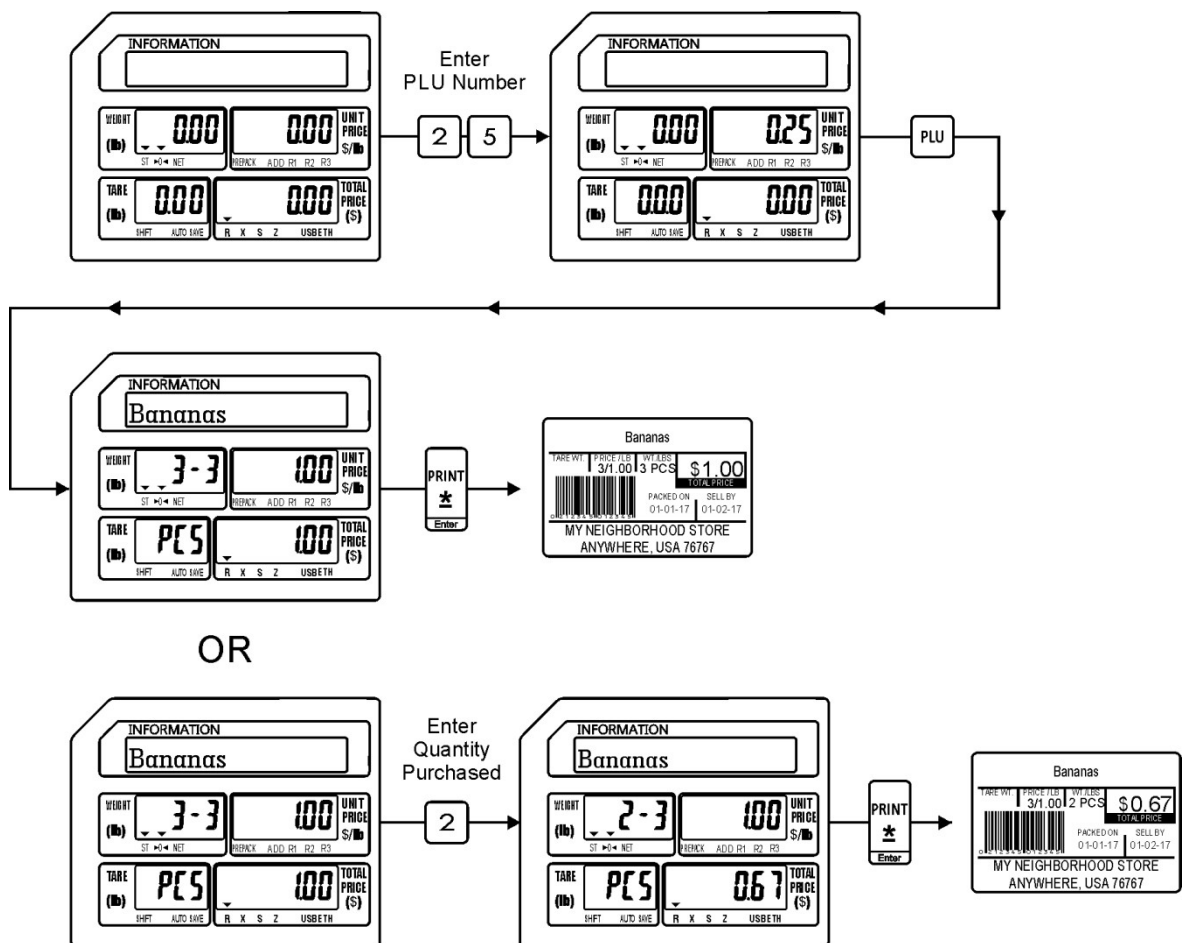

Note: There is no difference between the AUTO Print Mode and the Manual Print Mode in the By Count Mode operation.

8.5 Using the Override Key

8.5 Using the Override Key

The Override key is usually used to temporarily make changes to the Unit Price, Tare weight or Quantity information in a recalled PLU. When using the Override key the R1, R2 and R3 tri-marks (▼) will be lit to signify which input area is being changed. Refer to the chart below.

	R1	R2	R3
Weigh Mode (without Tare Override)	Not Used	Not Used	Unit Price
Weigh Mode (with Tare Override)	Tare Weight	Not Used	Unit Price
Non Weigh Mode	Quantity	Not Used	Unit Price
By Count Mode	Purchase Quantity	Priced at Quantity	Unit Price

Note: A password may be required to use the Override Key.

8.5.1 Weigh Mode Override

Using the Override key on a normal Weigh mode type PLU allows you to temporarily change the Unit Price and Preset Tare weight for that PLU.

Ex.) Override just the Unit Price for PLU #12 Ground Beef which has a Preset Tare weight of -0.05 lbs and a Unit Price of \$2.99 /lb with a new Unit Price of \$2.59 /lb.

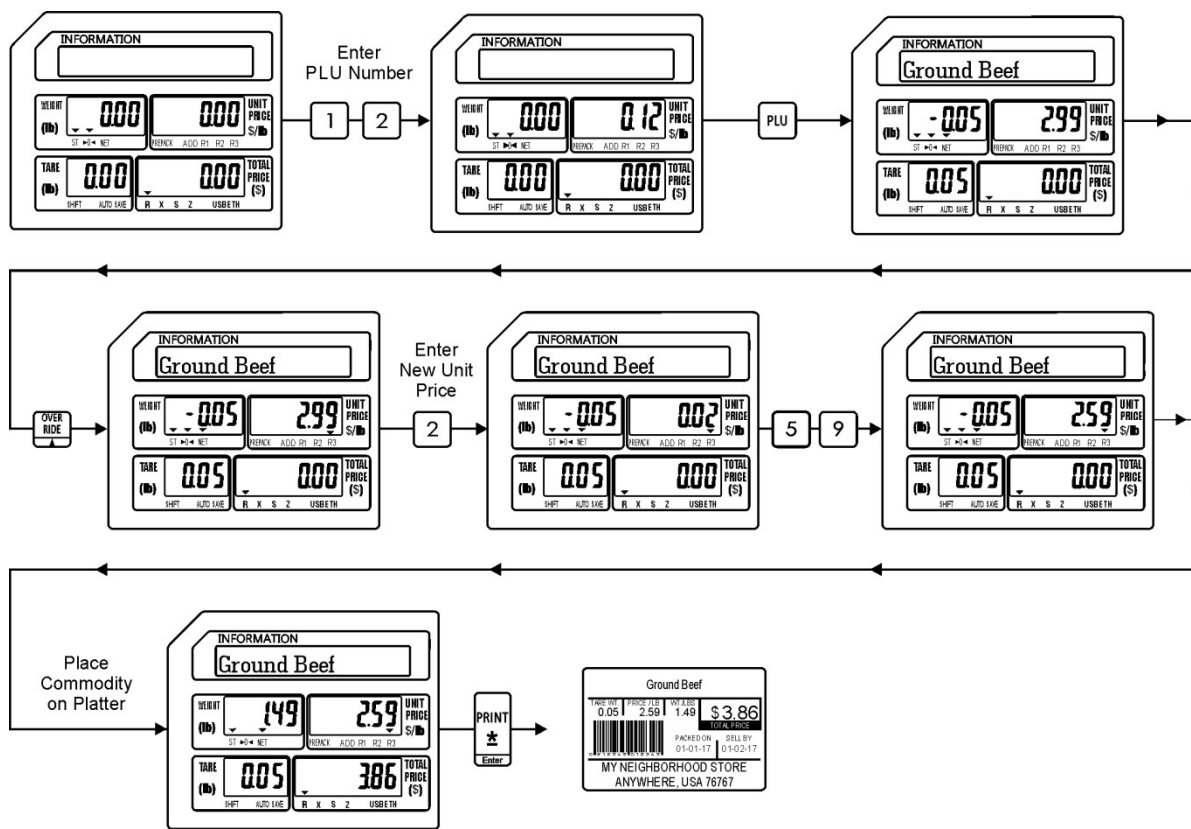

8.5.1 Weigh Mode Override

Ex.) Override the Preset Tare weight and Unit Price for PLU #12 Ground Beef which has a Preset Tare weight of -0.05 lbs and a Unit Price of \$2.99 /lb with a new Tare weight of -0.10 lbs and a new Unit Price of \$2.59 /lb.

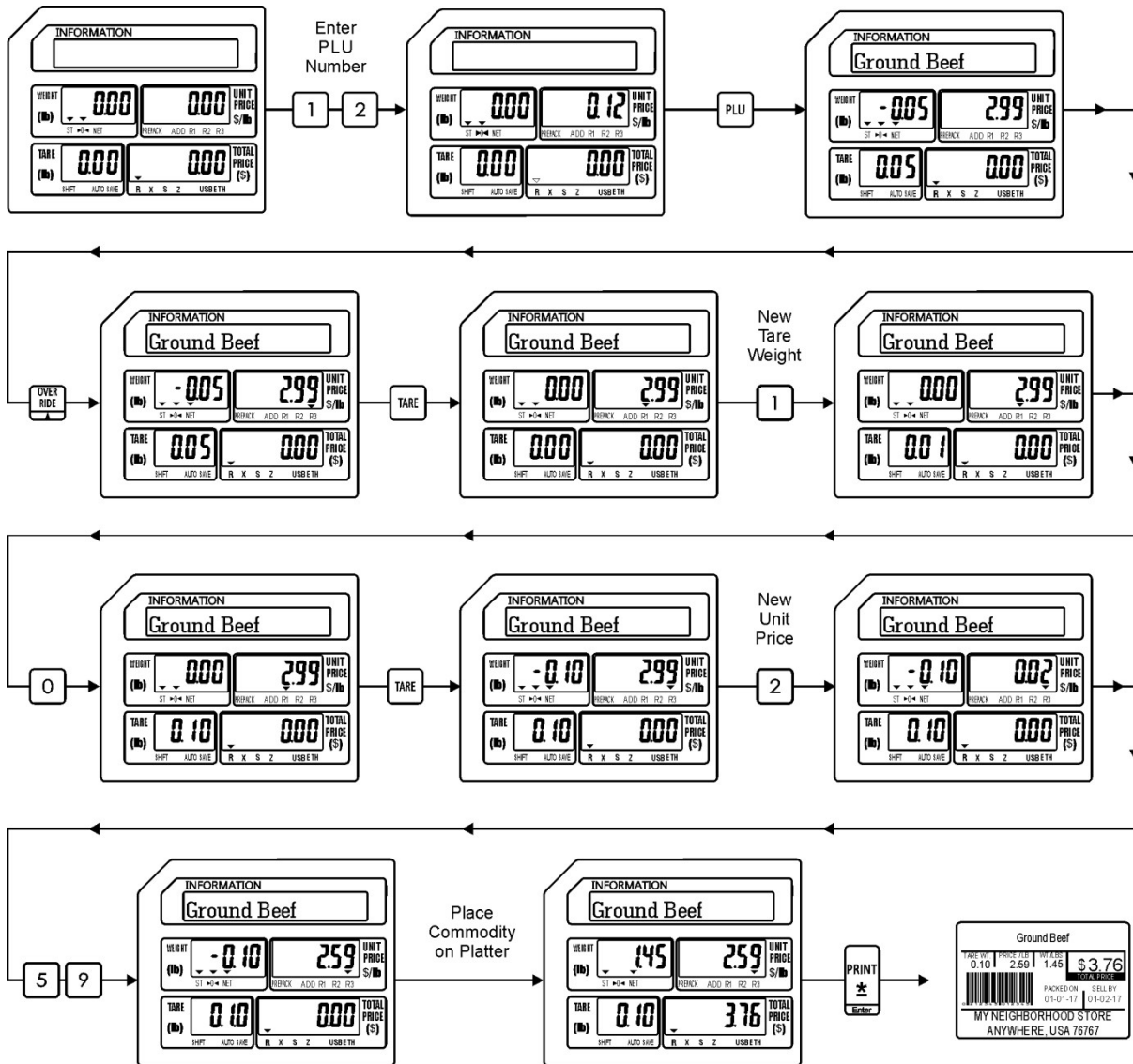

8.5.2 Non Weigh Mode Override

8.5.2 Non Weigh Mode Override

In the Non Weigh mode the Override key can be used to change the Quantity Purchased and the Unit Price of the recalled PLU.

Ex.) Override the Quantity Purchased and the Unit Price for PLU #15 Apple, which is normally priced at 1 for 29 cents with a new Quantity of 2 and a new Unit Price of 20 cents.

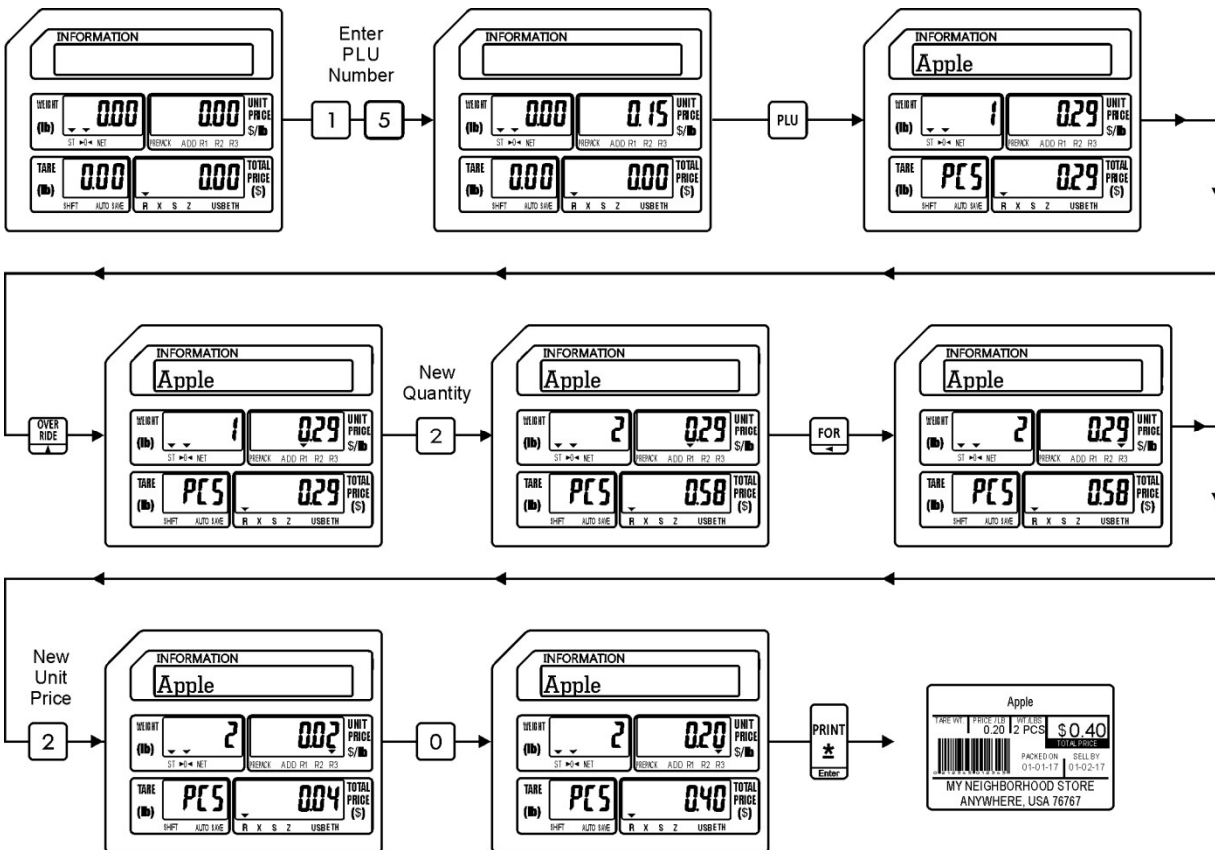

8.5.3 By Count Mode Override

8.5.3 By Count Mode Override

In the By Count mode the Override key allows you to change the Quantity Purchased, the Priced at Quantity and the Unit Price of the recalled PLU.

Ex.) Override only the Priced at Quantity and the Unit Price of PLU #25 Bananas, which are normally priced at 3 for \$1.00 with a new Priced at Quantity of 6 and a new Unit Price of \$1.50.

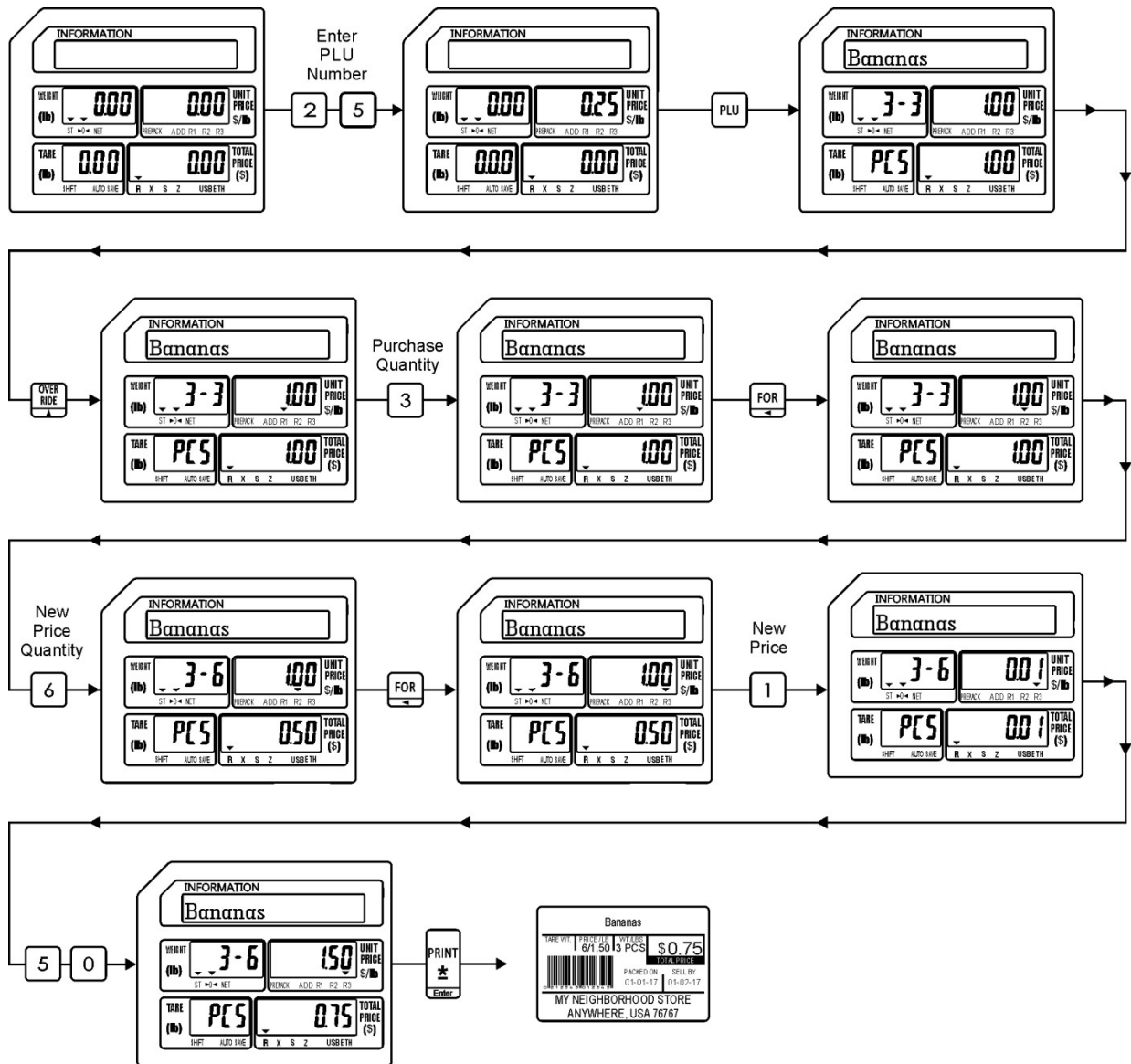

8.6 Miscellaneous PLU Operations

8.6 Miscellaneous PLU Operations

There are three Miscellaneous (MISC) PLU keys available to use when a PLU has not been programmed for a particular item in the scale. By using one of the three individual MISC keys, items may be sold as a Weighed, Non Weighed or By Count type PLU.

Note: The MISC keys may be programmed to require a password.

8.6.1 MISC Weigh Mode (without Tare Weight)

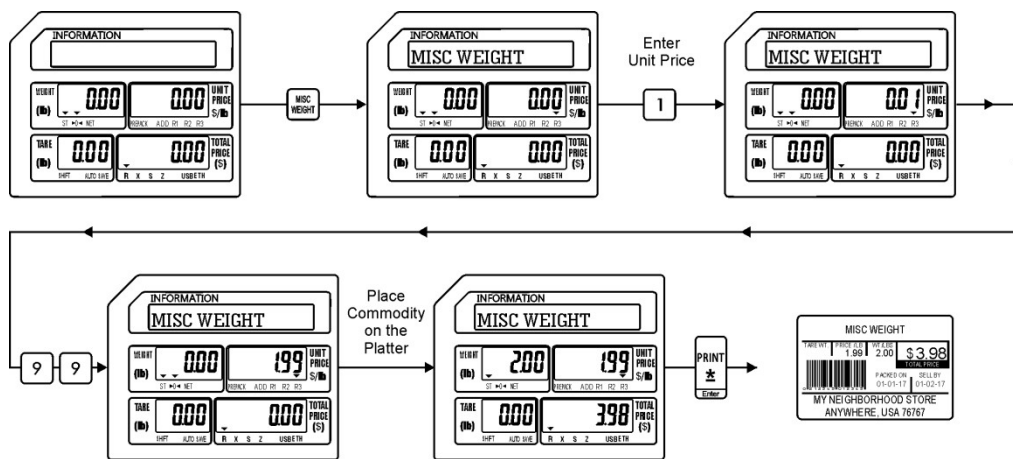

8.6.2 MISC Weigh Mode (with Tare Weight)

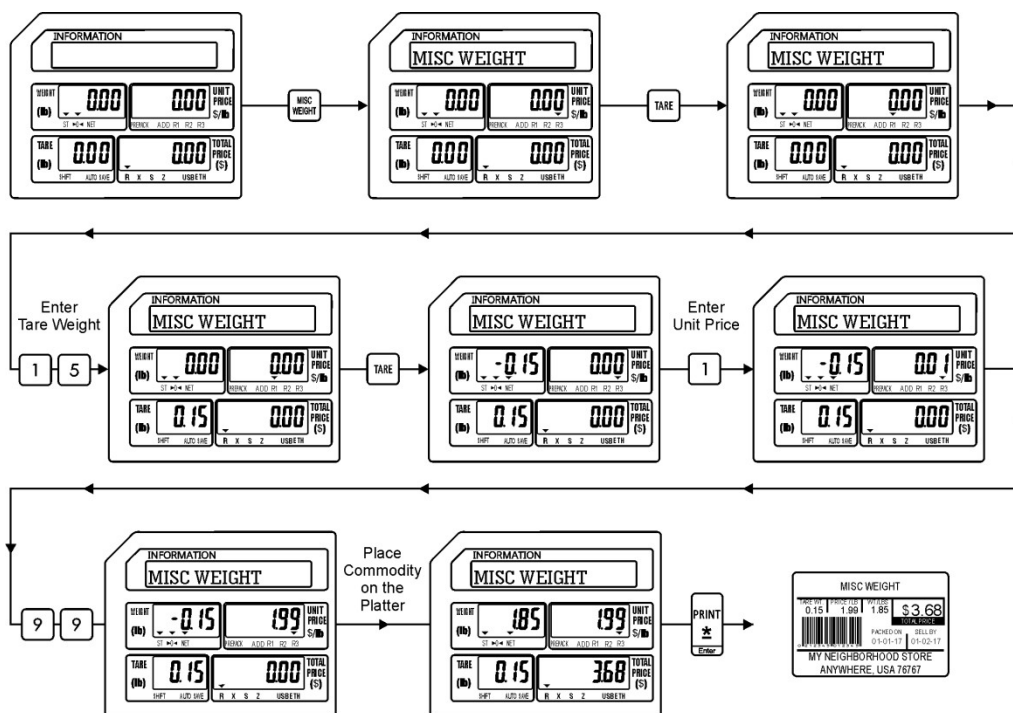

8.6.3 MISC Non Weigh Mode Operations

8.6.3 MISC Non Weigh Mode

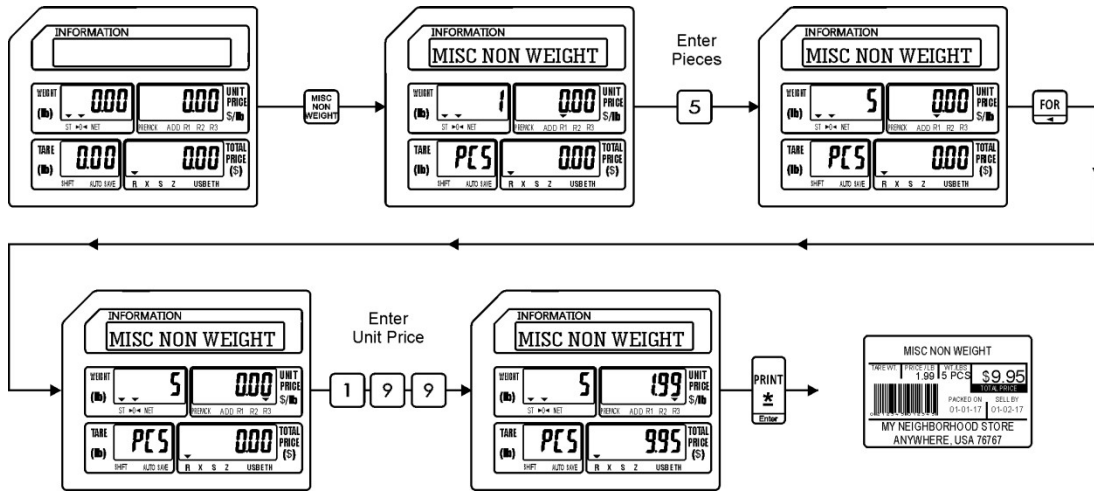

8.6.4 MISC By Count Mode

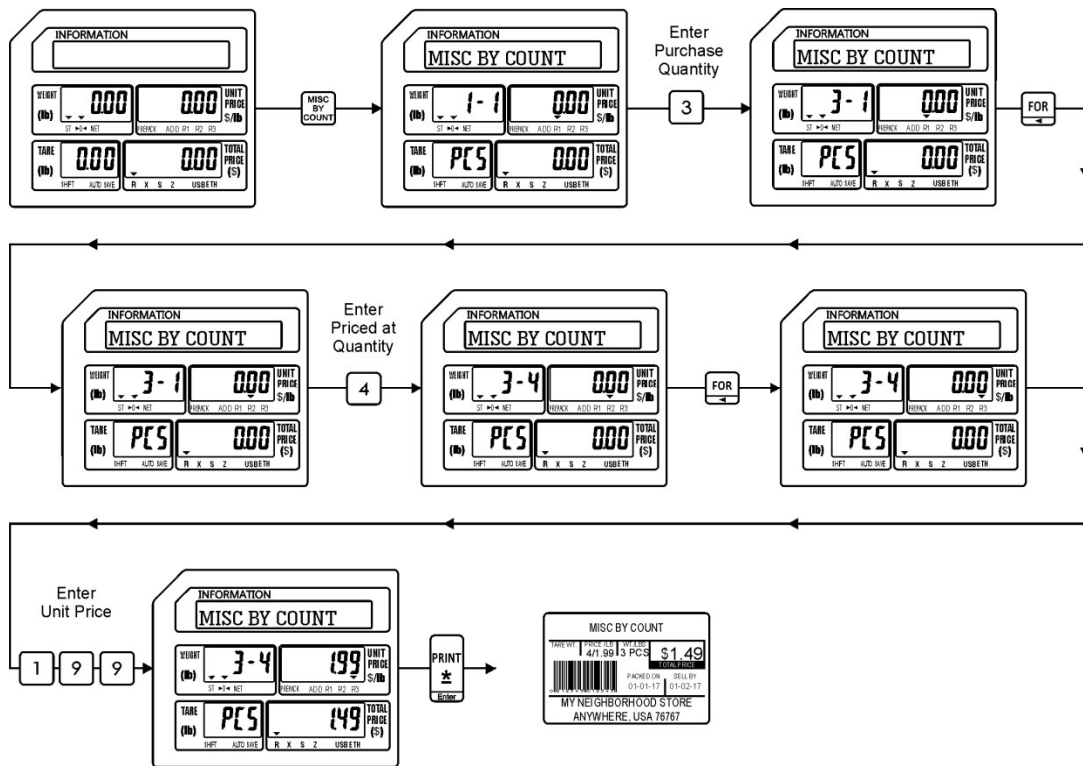

8.7 Preset Count Operations

8.7 Preset Count Operations

The Preset Count key is used to issue multiple labels for a recalled PLU. It may only be used on Non Weight and By Count type PLU's.

8.7.1 Preset Count using Non Weight PLU

Ex.) A quantity of 10 labels are needed for lettuce.

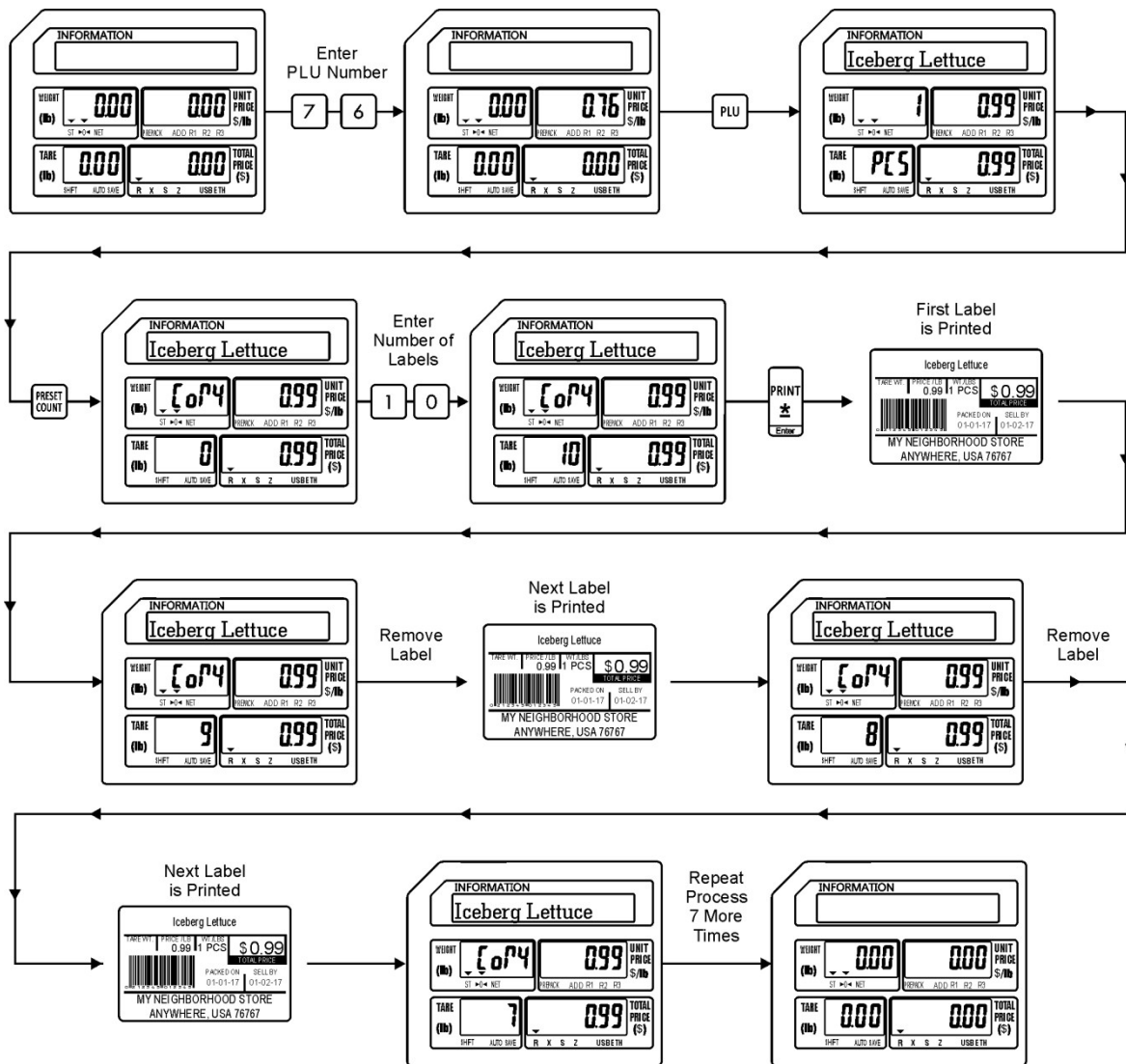

8.7.2 Preset Count using By Count PLU

8.7.2 Preset Count using By Count PLU

Ex.) A quantity of 10 labels is required for Bananas.

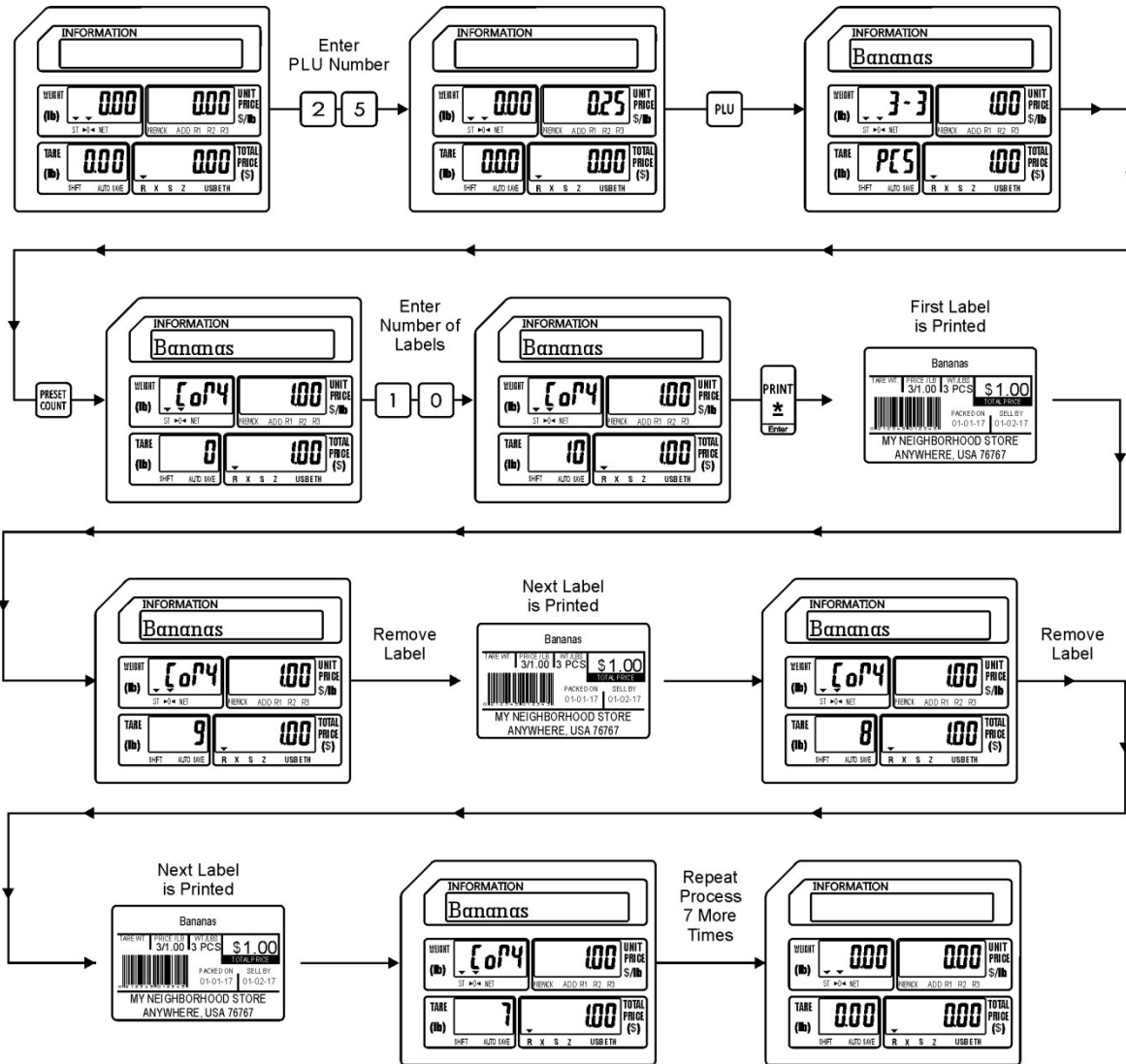

8.8 SAVE Key Operations

The SAVE key may be used to retain a recalled PLU's information. The type of information that is saved depends on the PLU type that is recalled.

8.8.1 Weigh Mode Operations with SAVE key

The information that is saved may be the Unit Price information and Preset Tare Weight.

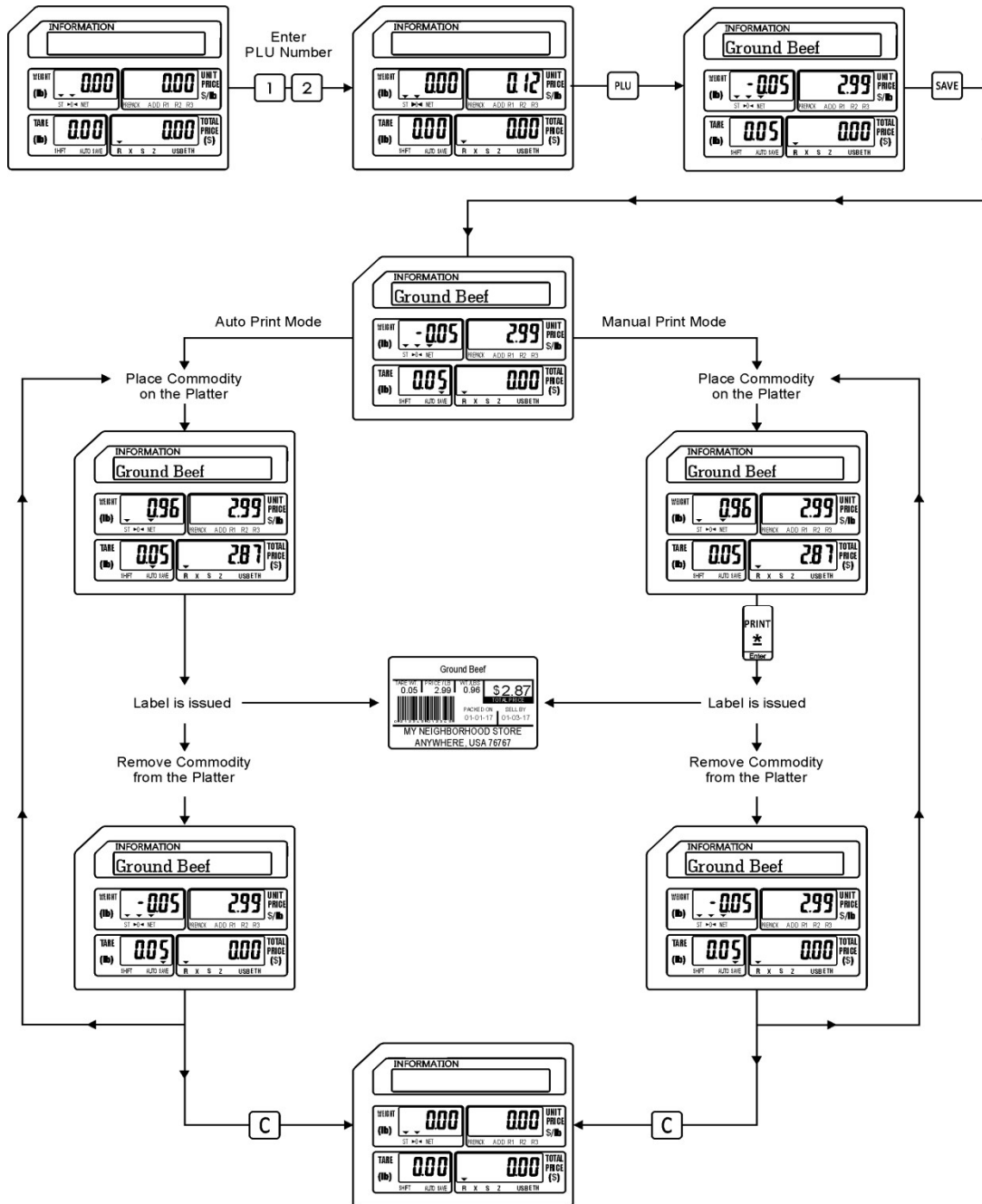

8.8.2 Non Weigh Mode using the SAVE key

8.8.2 Non Weigh Mode Operations with SAVE key

The information that is saved may be the Piece Count and the Unit Price.

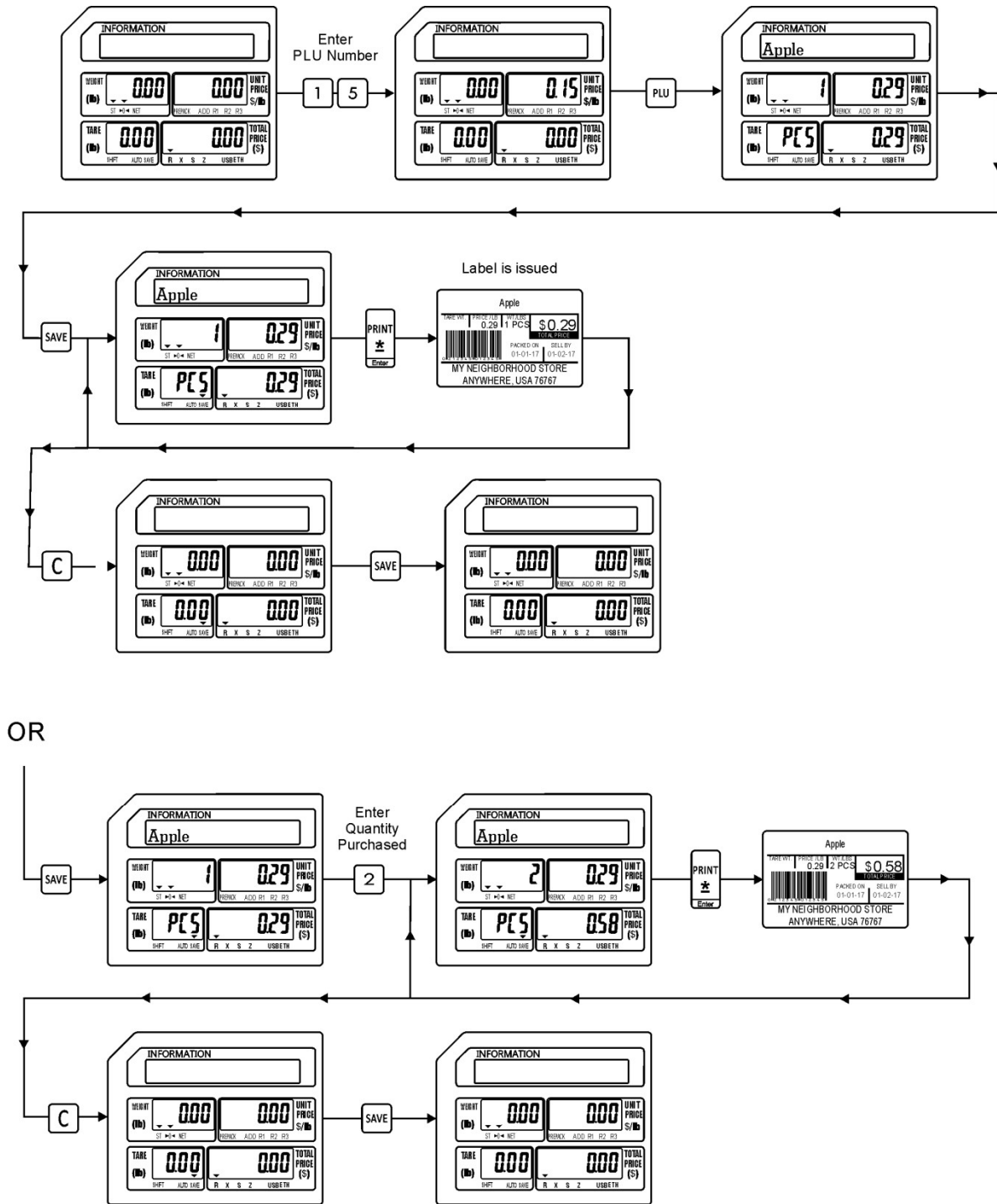

8.8.3 By Count Mode using the SAVE key

8.8.3 By Count Mode Operations with SAVE Key

The information saved may be the Quantity Purchased and Unit Price.

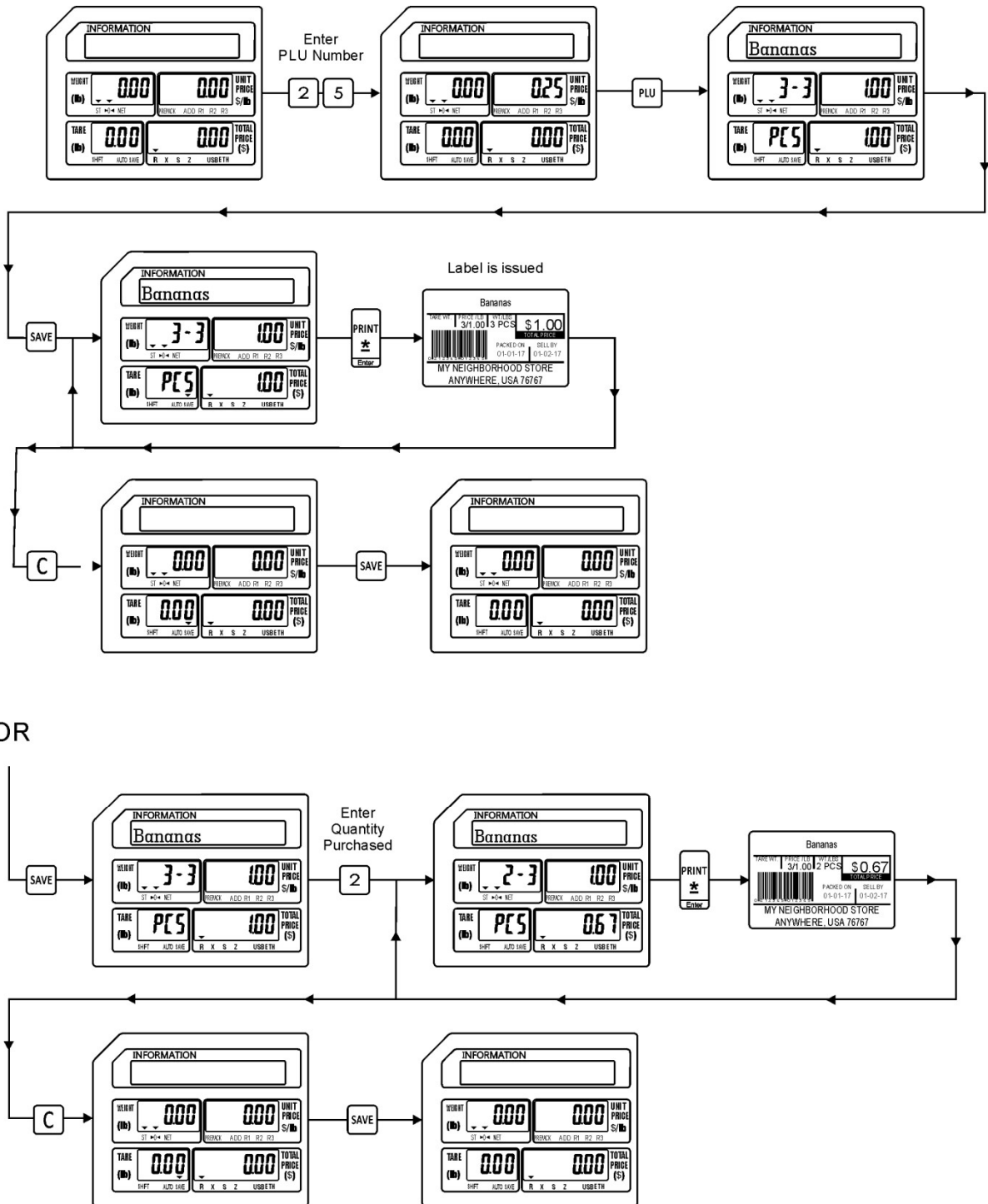

8.9 PLU Type Change Operations

8.9 PLU Type Change Operations

This special operation allows the operator to temporarily change a Weigh Mode PLU to a By Count Mode PLU.

Ex.) Change PLU #79 Onions from \$2.99 per pound to 3 Onions for \$1.29.

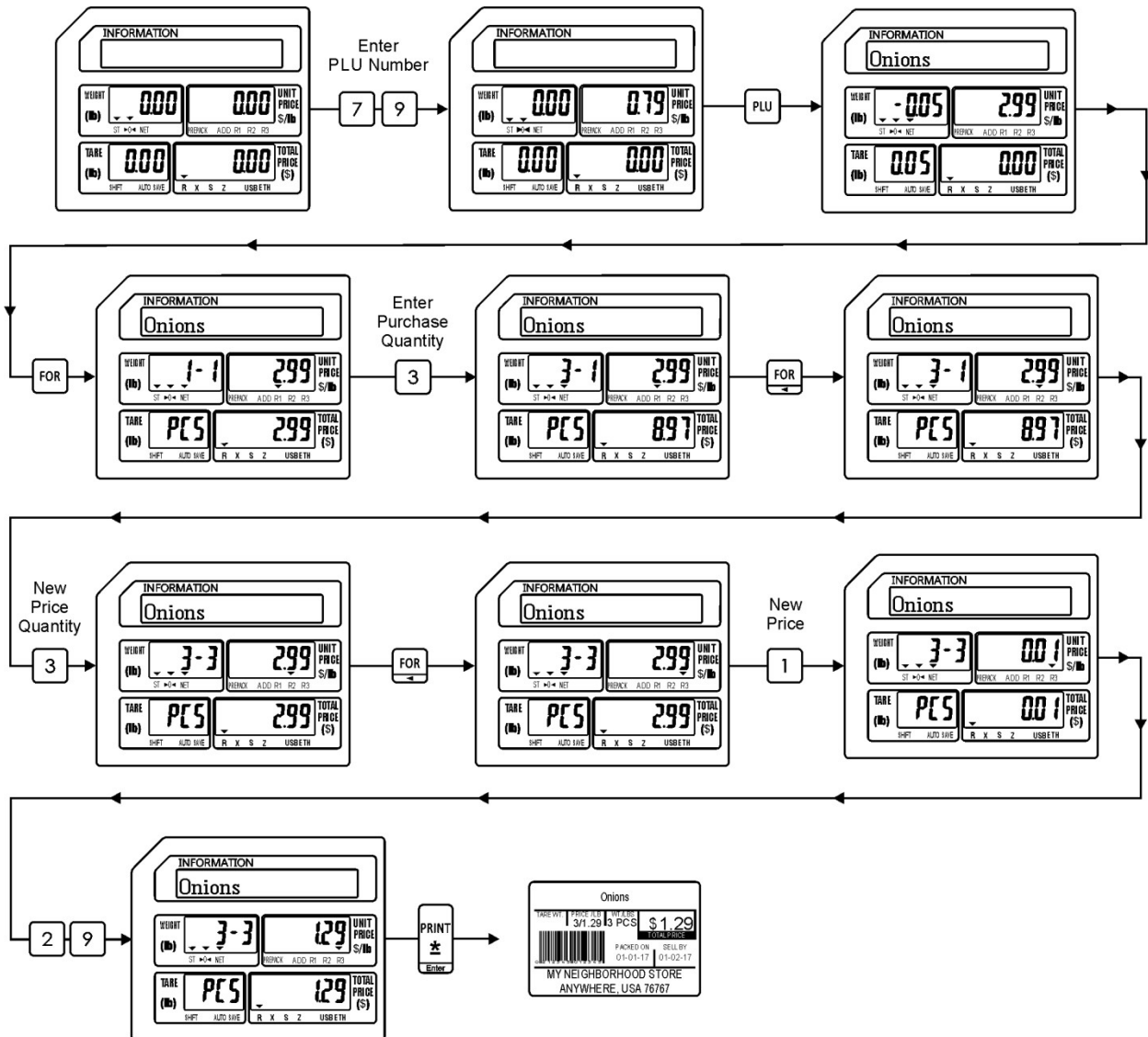

Note: PLU Type Change is only available for changing a Weigh Mode PLU into a By Count PLU.

9. Programming (S Mode)

Most of the information used in the scale is entered using the S Mode. (To access the S Mode press the **MODE** twice.) Items like PLU or commodity information, Store Name and Address, Speed Keys, Date/Time and Discount Information can be programmed using the built in programming keyboard. The procedures used to program information into the scale are outlined in this section of the manual.

- | | | | |
|--|---|--|--|
| | <p>S0 PLU Fields Visible
Used to select which PLU fields will be programmable while programming PLU information.</p> | | <p>S7 Upgrade
Used to perform System Upgrades.</p> |
| | <p>S1 PLU File
Used to program all PLU information.</p> | | <p>S8 System Time File
Used to program the Time and Date information.</p> |
| | <p>S2 Shop Name File
Used to program Store Names and Addresses.</p> | | <p>S9 Browse System File
Used to Browse System File information like number of PLU's, Departments, Groups, Pictures, etc.</p> |
| | <p>S3 Department File
Used to program Department information.</p> | | <p>S10 Browse CAL Record
Used to Browse the Calibration records of the scale.</p> |
| | <p>S4 Main Group File
Used to program Main Group information.</p> | | <p>S11 MMX Discount Rate
Used to assign PLU Discounts by a percentage rate.</p> |
| | <p>S5 PLU Key File
Used to program PLU Speed Key information.</p> | | <p>S12 MMX Discount Price
Used to assign PLU Discounts using a new unit price.</p> |
| | <p>S6 Function Key File
Used to assign special Function Keys to the Speed Key keyboard.</p> | | <p>S13 Clerk Number
Used to program Clerk information.</p> |

9.1 PLU Fields Visible (S0 Mode)
9.1 PLU Fields Visible (S0 Mode)

The PLU Fields Visible function allows you to select the PLU information fields that will be displayed while programming PLU's in the S Mode - S1 PLU File. This function should be completed prior to programming any PLU information in the S Mode – S1 PLU File. Refer to the list below for all of the possible PLU information fields available.

Mode No.	Field Name	Remarks
S0.0	PLU No.	PLU Number (0-999999)
S0.1	Name	PLU Name (1-4 Lines, 30 characters per line)
S0.2	Unit Price	PLU Unit Price (0-9999.99)
S0.3	Price Max	PLU Maximum Price
S0.4	PLU Type	PLU Type (0-Weight, 1-Non Weight, 2-By Count)
S0.5	Label Format*	PLU Label Format Number (0-99)
S0.6	Barcode Format*	PLU Barcode Format Number(0-99)
S0.7	F1F2*	PLU Barcode Flag Number (0-99)
S0.8	Item Code	PLU Item Code (0-999999)
S0.9	BCD Type*	Barcode Type (0-Weight, 1-Qty, 2-Price)
S0.10	Main Group No	PLU Main Group Number (0-999999)
S0.11	Tax No	Tax Number (0-9)
S0.12	BLC No	N/A
S0.13	Tag No	N/A
S0.14	WT Unit	PLU Weight Unit
S0.15	Sell By Date	PLU Sell By Date (0-999) added to Packed Date
S0.16	Sell By Time	PLU Sell By Time (0-99) added to Packed Time
S0.17	Cook By Date	PLU Cook By Date (0-999)added to Packed Date
S0.18	Pack Date	PLU Packed Date (0-999) added to current date
S0.19	Pack Time	PLU Packed Time (0-99) added to current time
S0.20	VIP Price	PLU Special Customer Price
S0.21	Cost Price	PLU Cost Price
S0.22	Tare	Weight PLU Tare Weight
S0.23	Qty	Non Weight or By Count PLU Piece Count
S0.24	Net Wt	PLU Net Weight
S0.25	Message	Special Sales Message
S0.26	Ingredients	PLU Ingredients
S0.27	State	N/A
S0.28	Prt Sell By Date	Print PLU Sell By Date
S0.29	Prt Sell By Time	Print PLU Sell By Time

9.1 PLU Fields Visible (S0 Mode)

S0.30	Prt Cook By Date	Print PLU Cook By Date
-------	------------------	------------------------

Mode No.	Field Name	Remarks
S0.31	Prt Pack Date	Print PLU Packed Date
S0.32	Prt Pack Time	Print PLU Packed Time
S0.33	Enable Discount	Enable or Disable PLU Discount
S0.34	Can't Sell	PLU Sale Prohibit
S0.35	Enable Limit Price	Enable PLU Price Limit
S0.36	Nutrition	PLU Nutrition Information

Field Names marked with an "" may appear or not appear during PLU programming based on SPEC settings. These fields should be set to a "1" by default.*

9.1.1 Selecting PLU Fields

To select the PLU Fields that will be used in the S Mode – S1 PLU File program follow the procedures outlined below.

Note: You may save the information entered at any time and exit this program by pressing the SAVE key then the FEED/ESC key. You may also exit this program without saving any entered information by pressing the FEED/ESC key at any time.

1.) Start at the normal weigh mode screen

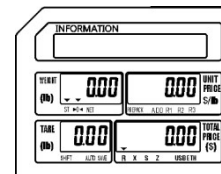

2.) Press the Mode Key twice

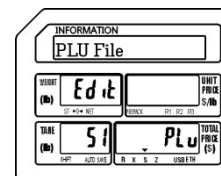

3.) Press the Override key once

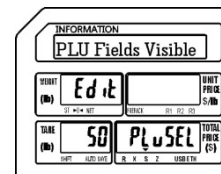

4.) Press the Print/* key

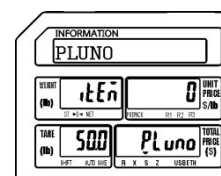

9.1.1 Selecting PLU Fields (SO Mode)

5.) Select PLU Number Field Status

0 = Not Visible
1 = Visible

Ex.) Make PLU Number Field visible by pressing the number one key.

Press the Print/* key.

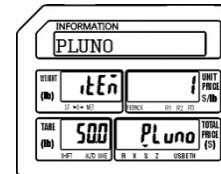
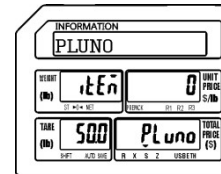

6.) Select PLU Name Field Status

0 = Not Visible
1 = Visible

Ex.) Make PLU Name Field visible by pressing the number one key.

Press the Print/* key.

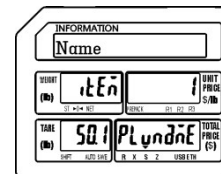
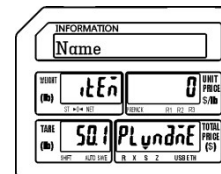
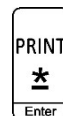

7.) Select Unit Price Field Status

0 = Not Visible
1 = Visible

Ex.) Make Unit Price Field visible by pressing the number one key.

Press the Print/* key.

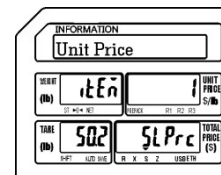
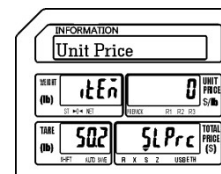
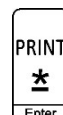

9.1.1 Selecting PLU Fields (S0 Mode)

8.) Select Price Max Field Status

0 = Not Visible
1 = Visible

Ex.) Make Price Max Field Not Visible by pressing the number zero key.

Press the Print/* key.

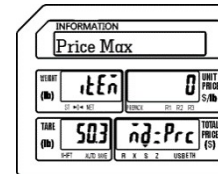
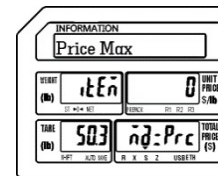

9.) Select PLU Type Field Status

0 = Not Visible
1 = Visible

Ex.) Make PLU Type Field visible by pressing the number one key.

Press the Print/* key.

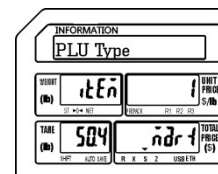
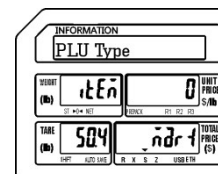

10.) Select Label Format Field Status

0 = Not Visible
1 = Visible

Note: If SPEC 14 is > 0 the Label Format Field will not be visible in S Mode – S1 PLU File regardless of this setting.

Ex.) Make Label Format Field visible by pressing the number one key.

Press the Print/* key.

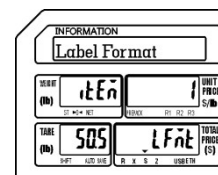
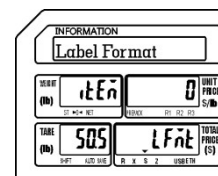
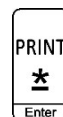

9.1.1 Selecting PLU Fields (S0 Mode)

11.) Select Barcode Format Field Status

0 = Not Visible
1 = Visible

Note: If SPEC 0 is = 1 the Barcode Format Field will not be visible in S Mode – S1 PLU File regardless of this setting.

Ex.) Make Barcode Format Field visible by pressing the number one key.

Press the Print/* key.

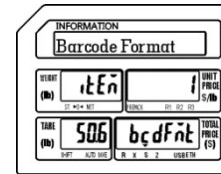
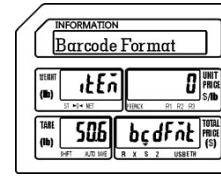
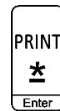

12.) Select F1F2 Field Status

0 = Not Visible
1 = Visible

Note: If SPEC 0 is = 1 the F1F2 Field will not be visible in S Mode – S1 PLU File regardless of this setting.

Ex.) Make the F1F2 Field visible by pressing the number one key.

Press the Print/* key.

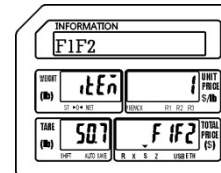
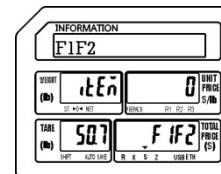

13.) Select Item Code Field Status

0 = Not Visible
1 = Visible

Ex.) Make Item Code Field visible by pressing the number one key.

Press the Print/* key.

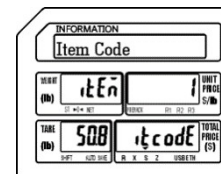
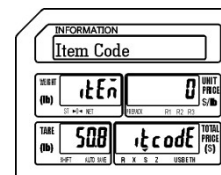
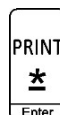

9.1.1 Selecting PLU Fields (S0 Mode)

14.) Select Barcode Type Field Status

0 = Not Visible
1 = Visible

Note: If SPEC 0 is = 1 the Barcode Type Field will not be visible in S Mode – S1 PLU File regardless of this setting.

Ex.) Make Barcode Type Field visible by pressing the number one key.

Press the Print/* key.

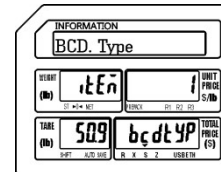
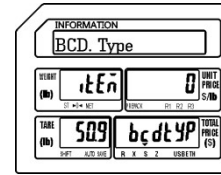
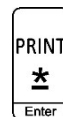

15.) Select Main Group No. Field Status

0 = Not Visible
1 = Visible

Ex.) Make Main Group No. Field not visible by pressing the number zero key.

Press the Print/* key.

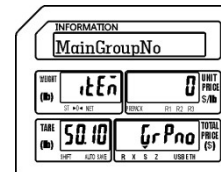
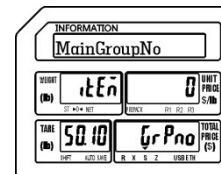

16.) Select Tax Number Field Status

0 = Not Visible
1 = Visible

Ex.) Make Tax Number Field not visible by pressing the number zero key.

Press the Print/* key.

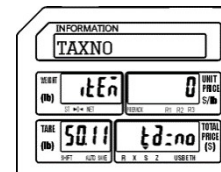
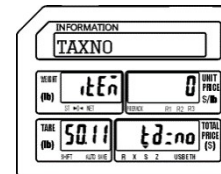
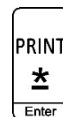

9.1.1 Selecting PLU Fields (S0 Mode)

17.) Select BLC No. Field Status

0 = Not Visible
1 = Visible

Ex.) Make BLC No. Field not visible by pressing the number zero key.

Press the Print/* key.

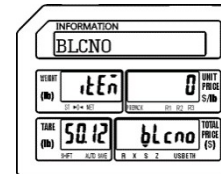
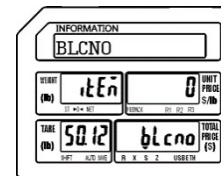

18.) Select Tag No. Field Status

0 = Not Visible
1 = Visible

Ex.) Make Tag No. Field not visible by pressing the number zero key.

Press the Print/* key.

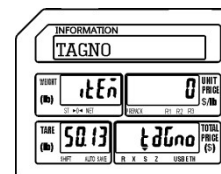
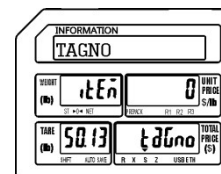
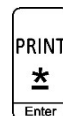

19.) Select Weight Unit Field Status

0 = Not Visible
1 = Visible

Ex.) Make Weight Unit Field not visible by pressing the number zero key.

Press the Print/* key.

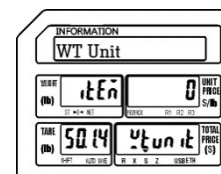
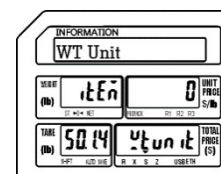
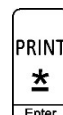

9.1.1 Selecting PLU Fields (S0 Mode)

20.) Select Sell By Date Field Status

0 = Not Visible
1 = Visible

Ex.) Make Sell By Date Field visible by pressing the number one key.

Press the Print/* key.

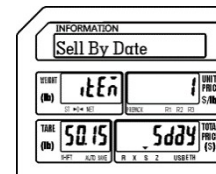
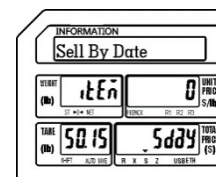

21.) Select Sell By Time Field Status

0 = Not Visible
1 = Visible

Ex.) Make Sell By Time Field visible by pressing the number one key.

Press the Print/* key.

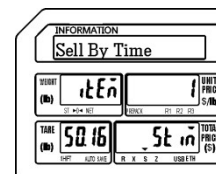
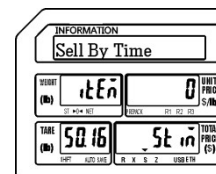

22.) Select Cook By Date Field Status

0 = Not Visible
1 = Visible

Ex.) Make Cook By Date Field not visible by pressing the number zero key.

Press the Print/* key.

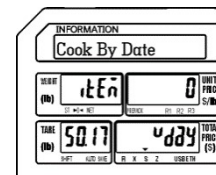
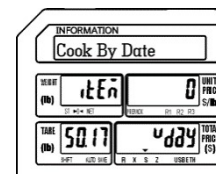

9.1.1 Selecting PLU Fields (S0 Mode)

23.) Select Pack Date Field Status

0 = Not Visible
1 = Visible

Ex.) Make Pack Date Field not visible by pressing the number zero key.

Press the Print/* key.

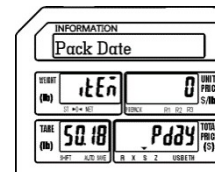
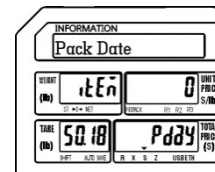

24.) Select Pack By Time Field Status

0 = Not Visible
1 = Visible

Ex.) Make Pack By Time Field not visible by pressing the number zero key.

Press the Print/* key.

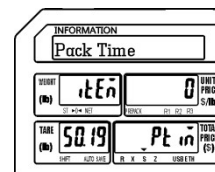
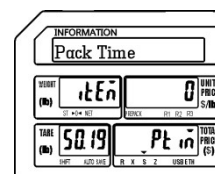

25.) Select VIP Price Field Status

0 = Not Visible
1 = Visible

Ex.) Make VIP Price Field not visible by pressing the number zero key.

Press the Print/* key.

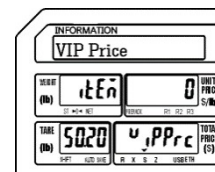
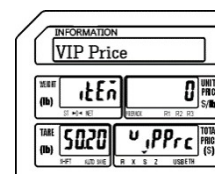

9.1.1 Selecting PLU Fields (S0 Mode)

26.) Select PLU Cost Price Field Status

0 = Not Visible
1 = Visible

Ex.) Make PLU Cost Price Field not visible by pressing the number zero key.

0

Press the Print/* key.

PRINT
*
Enter

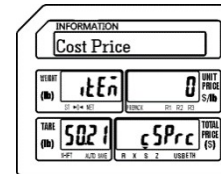
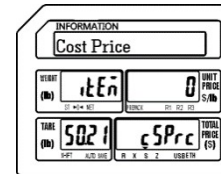

27.) Select Tare Weight Field Status

0 = Not Visible
1 = Visible

Ex.) Make Tare Weight Field visible by pressing the number one key.

1

Press the Print/* key.

PRINT
*
Enter

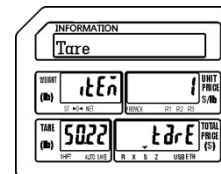
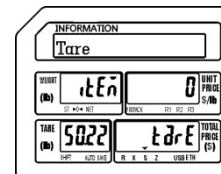

28.) Select Quantity Field Status

0 = Not Visible
1 = Visible

Ex.) Make Quantity Field visible by pressing the number one key.

1

Press the Print/* key.

PRINT
*
Enter

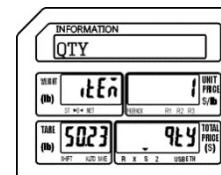
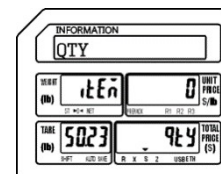

9.1.1 Selecting PLU Fields (S0 Mode)

29.) Select Net Weight Field Status

0 = Not Visible
1 = Visible

Ex.) Make Net Weight Field not visible by pressing the number zero key.



Press the Print/* key.

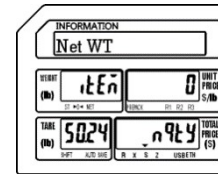
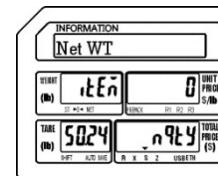
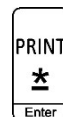

30.) Select Sales Message Field Status

0 = Not Visible
1 = Visible

Ex.) Make Sales Message Field not visible by pressing the number zero key.



Press the Print/* key.

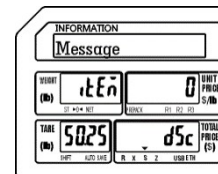
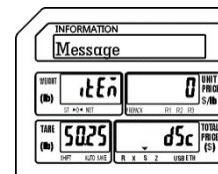

31.) Select Ingredients Field Status

0 = Not Visible
1 = Visible

Ex.) Make Ingredients Field visible by pressing the number one key



Press the Print/* key.

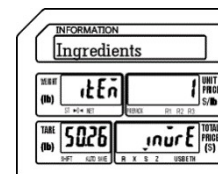
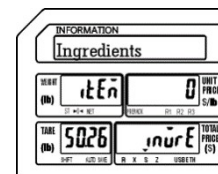
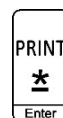

9.1.1 Selecting PLU Fields (S0 Mode)

32.) Select State Field Status

0 = Not Visible
1 = Visible

Ex.) Make State Field not visible by pressing the number zero key.

Press the Print/* key.

0

PRINT
*
Enter

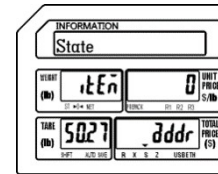
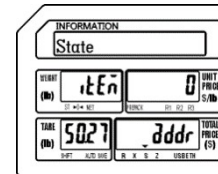

33.) Select Print Sell By Date Field Status

0 = Not Visible
1 = Visible

Ex.) Make Print Sell By Date Field visible by pressing the number one key.

Press the Print/* key.

1

PRINT
*
Enter

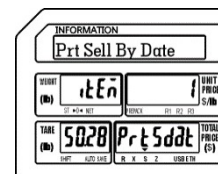
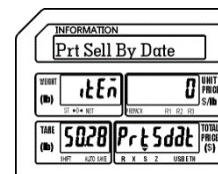

34.) Select Print Sell By Time Field Status

0 = Not Visible
1 = Visible

Ex.) Make Print Sell By Time Field visible by pressing the number one key.

Press the Print/* key.

1

PRINT
*
Enter

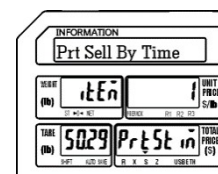
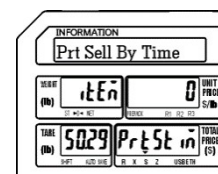

9.1.1 Selecting PLU Fields (S0 Mode)

35.) Select Print Cook By Date Field Status

0 = Not Visible
1 = Visible

Ex.) Make Print Cook By Date Field not visible by pressing the number zero key.

Press the Print/* key.

0

PRINT
*
Enter

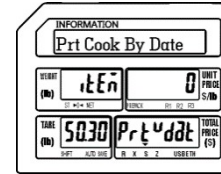
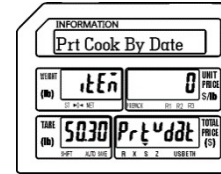

36.) Select Print Pack Date Field Status

0 = Not Visible
1 = Visible

Ex.) Make Print Pack Date Field visible by pressing the number one key.

Press the Print/* key.

1

PRINT
*
Enter

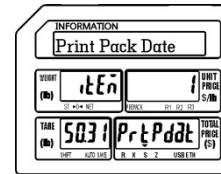
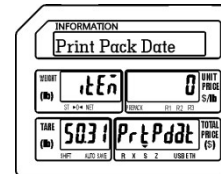

37.) Select Print Pack Time Field Status

0 = Not Visible
1 = Visible

Ex.) Make Print Pack Time Field not visible by pressing the number zero key.

Press the Print/* key.

0

PRINT
*
Enter

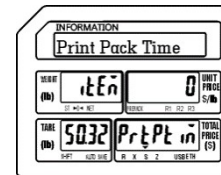
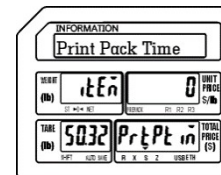

9.1.1 Selecting PLU Fields (S0 Mode)

38.) Select Enable Discount Field Status

0 = Not Visible
1 = Visible

Ex.) Make Enable Discount Field visible by pressing the number one key.

Press the Print/* key.

1

PRINT
*
Enter

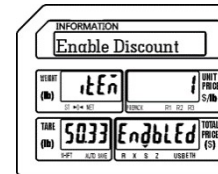
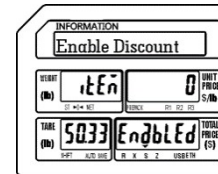

39.) Select Sale Inhibit Field Status

0 = Not Visible
1 = Visible

Ex.) Make Sale Inhibit Field not visible by pressing the number zero key.

Press the Print/* key.

0

PRINT
*
Enter

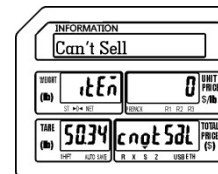
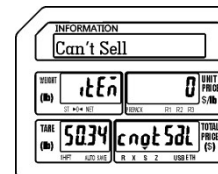

40.) Select Enable Price Limit Field Status

0 = Not Visible
1 = Visible

Ex.) Make Enable Price Limit Field not visible by pressing the number zero key.

Press the Print/* key.

0

PRINT
*
Enter

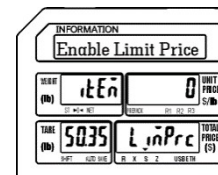
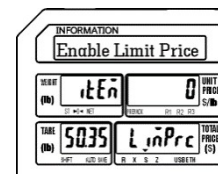

9.1.1 Selecting PLU Fields (S0 Mode)

41.) Select Nutrition Field Status

0 = Not Visible

1 = Visible

Ex.) Make Nutrition Field not visible by pressing the number zero key.



Press the SAVE key.



Press the FEED/ESC key.

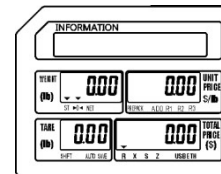
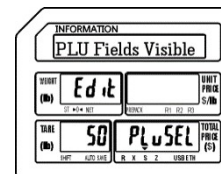
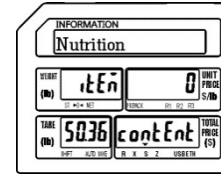
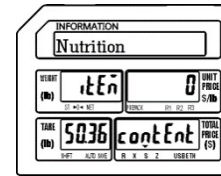

9.2 PLU File (S1 Mode)

The PLU File mode is used to program commodity or PLU information directly into the scale. There are 3 different types of PLU's available, Weigh Mode, Non Weigh Mode and By Count Mode. Each of the different types contains information that is similar such as name, price, expiration dates and ingredients. Each PLU type also contains some information that is unique based on the PLU type selected. The programming of each PLU type is explained separately in this section.

Note: Before entering any PLU information it is recommended to complete the programming of the S Mode – S0 PLU Fields Visible. This will ensure that all of the necessary PLU Fields will be available during the process of programming different types of PLU information.

9.2.1 Programming a Weigh Mode PLU (S1 Mode)

In the example below the PLU Fields that will be used have been programmed using the S Mode – PLU Fields Visible examples in the previous section.

Ex.) Create a Weigh Mode PLU for Ground Beef that has a Tare Weight of .05 lbs and a Unit Price of \$2.99/lb.

Note: You may save the information entered at any time and exit this program by pressing the SAVE key then the FEED/ESC key. You may also exit this program without saving any entered information by pressing the FEED/ESC key at any time.

1.) Start at the normal weigh mode screen

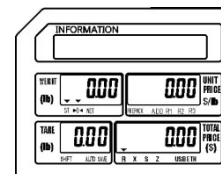

2.) Press the Mode Key twice

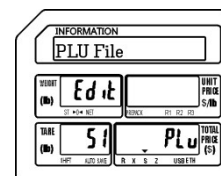

3.) Press the Print/* key

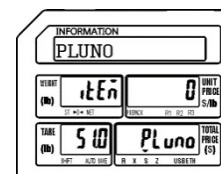
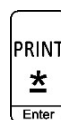

9.2.1 Programming a Weigh Mode PLU (S1 Mode)

4.) Enter the PLU Number

Ex.) Enter PLU Number 12 by pressing the number one key followed by the number two key.

Press the Print/* key.

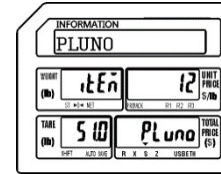
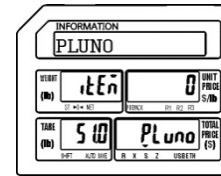

5.) Enter the PLU Name

Note: The PLU Name may be up to 4 lines of text. The number of characters printed on each line is determined by the font size of the PLU Name. The larger the font size the less characters that will be printed on each line

Ex.) Enter Ground Beef using the alpha keys on the programming keyboard.

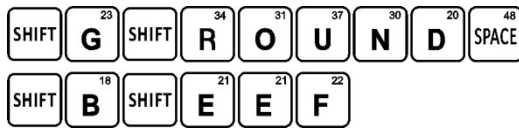

Press the Print/* key.

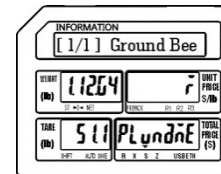
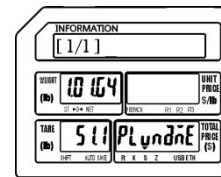

6.) Enter the Unit Price

Ex.) Enter a Unit Price of \$2.99 by pressing the number two key and then the number nine key twice.

Press the Print/* key.

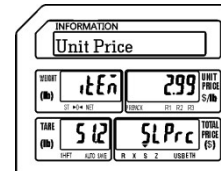
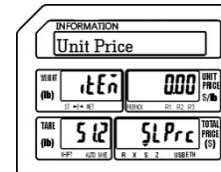
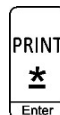
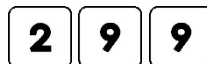

9.2.1 Programming a Weigh Mode PLU (S1 Mode)

7.) Enter the PLU Type

- 0 = Weigh type
- 1 = Non Weigh type
- 2 = By Count type

Ex.) Enter 0 for Weigh mode PLU Type by pressing the number zero key.



Press the Print/* key.

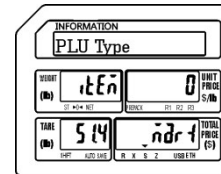
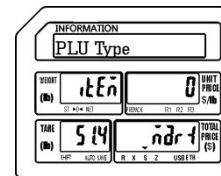

8.) Enter the Item Code

Note: The Item Code is used in the barcode to identify the PLU. It may be the same number as the PLU number or may be a different number.

Ex.) Enter an item code of 1212 using the number keys.



Press the Print/* key.

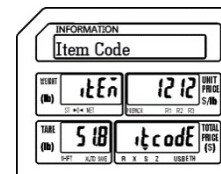
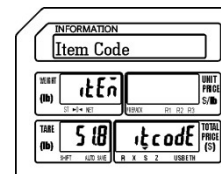

9.) Enter the Sell By Date

Note: The Sell By Date that is printed on the label is a result of adding the value (0 – 999 days) entered here to the Pack Date.

Ex.) Enter a Sell By Date of 5 days by pressing the number five key.



Press the Print/* key.

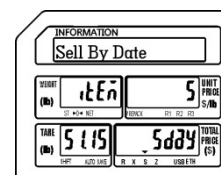
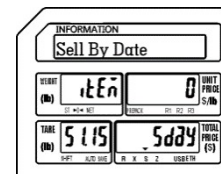
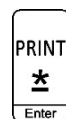

9.2.1 Programming a Weigh Mode PLU (S1 Mode)

10.) Enter the Sell By Time

Note: The Sell By Time that is printed on the label is a result of adding this value (0 – 99 hours) to the Pack Time.

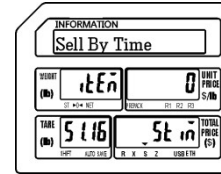

Ex.) Enter 0 for Sell By Time by pressing the number zero key.

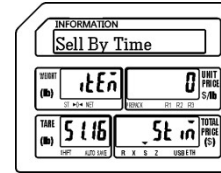

Press the Print/* key.

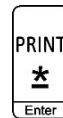

11.) Enter the Tare Weight

Note: The Tare Weight value must be in the resolution value of the scale.

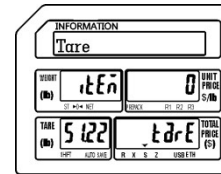

Ex.) Enter a Tare Weight value of .05 lbs by press the number five key.

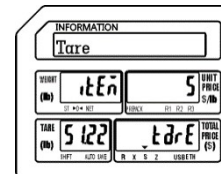

Press the Print/* key.



12.) Enter the Quantity

Note: The Quantity field is only used on Non Weight and By Count type PLU's. If a value is entered here it will be used if this PLU is Type Changed. (Section 8.9)

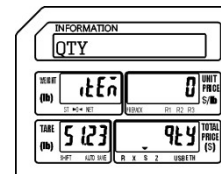

Ex.) Enter a Quantity of 1 by pressing the number one key.

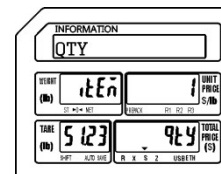

Press the Print/* key.

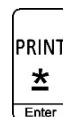

9.2.1 Programming a Weigh Mode PLU (S1 Mode)

13.) Enter the Ingredient Message

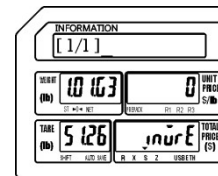

Ex.) The example PLU Ground Beef does not have any ingredients.

Press the Print/* key.



14.) Select Status of Print Sell By Date

- 0 = Don't Print Sell By Date
- 1 = Print Sell By Date

Note: The Printing of the Sell By Date on the label is controlled by this setting in each PLU.

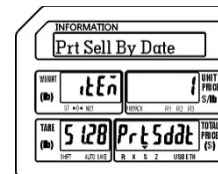

Ex.) Select a status of Print the Sell by Date by pressing the number one key.



Press the Print/* key.

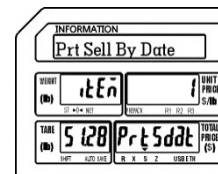
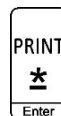

15.) Select Status of Print Sell By Time

- 0 = Don't Print Sell By Time
- 1 = Print Sell By Time

Note: The Printing of the Sell By Time on the label is controlled by this setting in each PLU.

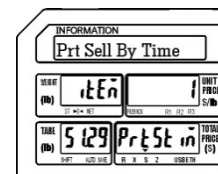

Ex.) Select a status of Don't Print the Sell By Time by pressing the number zero key.



Press the Print/* key.

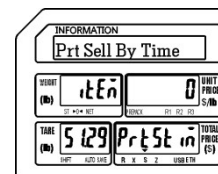
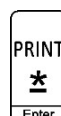

9.2.1 Programming a Weigh Mode PLU (S1 Mode)

16.) Select Status of Print Pack Date

- 0 = Don't Print Pack Date
- 1 = Print Pack Date

Note: The Printing of the Pack Date on the label is controlled by this setting in each PLU.

Ex.) Select a status of Print the Pack Date by pressing the number one key.

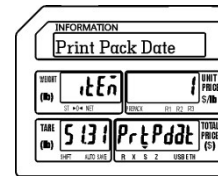

Press the Print/* key.

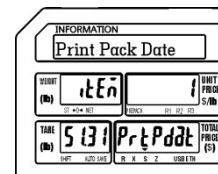

17.) Select Status of Discount

- 0 = Disable PLU Discount
- 1 = Enable PLU Discount

Note: The Discount status of each PLU is controlled by this setting.

Ex.) Select a status of Enable the PLU Discount by pressing the number one key.

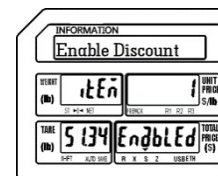

Press the Print/* key.

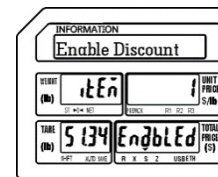

Press the SAVE key.

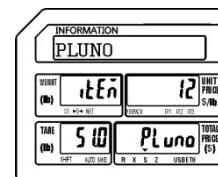

Press the FEED/ESC key.

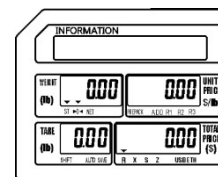
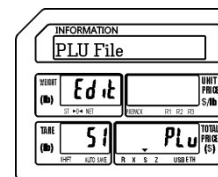

9.2.2 Programming a Non Weigh Mode PLU (S1 Mode)

9.2.2 Programming a Non Weigh Mode PLU (S1 Mode)

In the example below the PLU Fields that will be used have been programmed using the S Mode – PLU Fields Visible examples in the previous section.

Ex.) Create a Non Weigh Mode PLU for Apple that has a price of 1 for \$ 0.29.

Note: You may save the information entered at any time and exit this program by pressing the SAVE key then the FEED/ESC key. You may also exit this program without saving any entered information by pressing the FEED/ESC key at any time.

1.) Start at the normal weigh mode screen

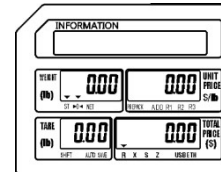

2.) Press the Mode Key twice

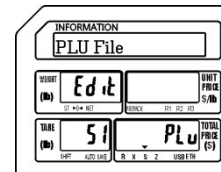

3.) Press the Print/* key

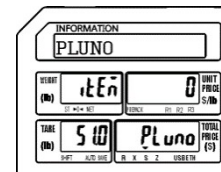

4.) Enter the PLU Number

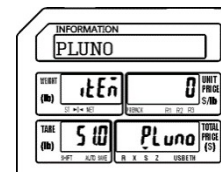

Ex.) Enter PLU Number 15 by pressing the number one key followed by the number five key.

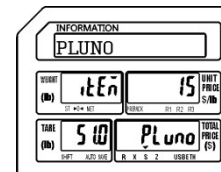

Press the Print/* key.

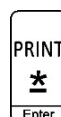

9.2.2 Programming a Non Weigh Mode PLU (S1 Mode)

5.) Enter the PLU Name

Note: The PLU Name may be up to 4 lines of text. The number of characters printed on each line is determined by the font size of the PLU Name. The larger the font size the less characters that will be printed on each line

Ex.) Enter Apple using the alpha keys on the programming keyboard.



Press the Print/* key.

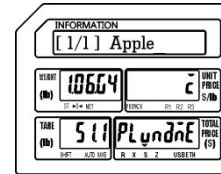
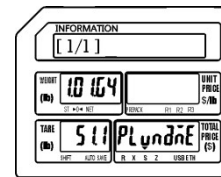

6.) Enter the Unit Price

Ex.) Enter a Unit Price of \$0.29 by pressing the number two key and then the number nine key.

Press the Print/* key.

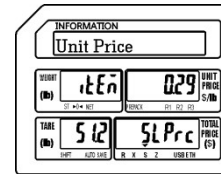
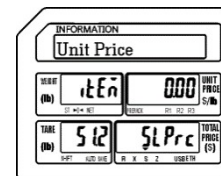

7.) Enter the PLU Type

- 0 = Weigh type
- 1 = Non Weigh type
- 2 = By Count type

Ex.) Enter 1 for Non Weigh mode PLU Type by pressing the number one key.

Press the Print/* key.

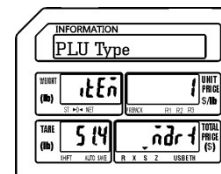
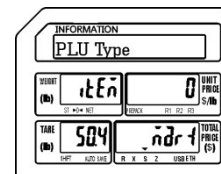
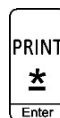

9.2.2 Programming a Non Weigh Mode PLU (S1 Mode)

8.) Enter the Item Code

Note: The Item Code is used in the barcode to identify the PLU. It may be the same number as the PLU number or may be a different number.

Ex.) Enter an item code of 2215 using the number keys.



Press the Print/* key.

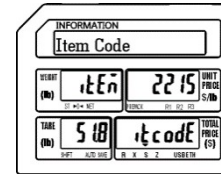
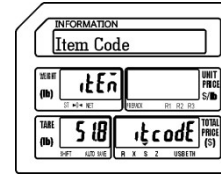

9.) Enter the Sell By Date

Note: The Sell By Date that is printed on the label is a result of adding the value (0 – 999 days) entered here to the Pack Date.

Ex.) Enter a Sell By Date of 7 days by pressing the number seven key.



Press the Print/* key.

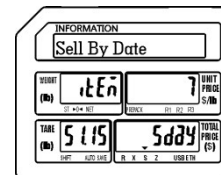
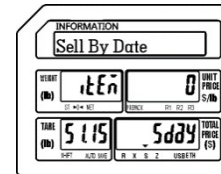

10.) Enter the Sell By Time

Note: The Sell By Time that is printed on the label is a result of adding the value (0 – 99 hours) entered here to the Pack Time.

Ex.) Enter a Sell By Time of 0 by pressing the number zero key.



Press the Print/* key.

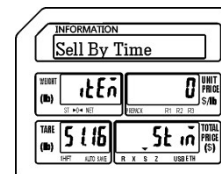
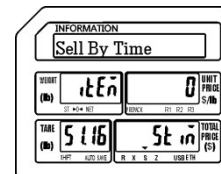
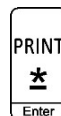

9.2.2 Programming a Non Weigh Mode PLU (S1 Mode)

11.) Enter the Tare Weight

Note: The Tare Weight is not used in the Non Weigh Mode.

Ex.) A Non Weight type PLU does not use the Tare Weight field.

Press the Print/* key.

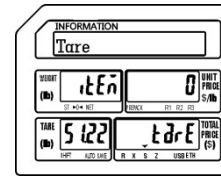

12.) Enter the Quantity

Ex.) Enter a Quantity of 1 by pressing the number one key.

Press the Print/* key.

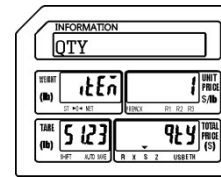
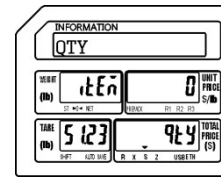

13.) Enter the Ingredient Message

Ex.) The example PLU Apple, does not have any ingredients.

Press the Print/* key.

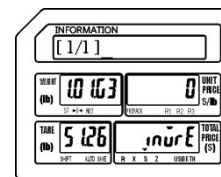
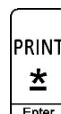

9.2.2 Programming a Non Weigh Mode PLU (S1 Mode)

14.) Select Status of Print Sell By Date

- 0 = Don't Print Sell By Date
- 1 = Print Sell By Date

Note: The Printing of the Sell By Date on the label is controlled by this setting in each PLU.

Ex.) Select a status of Print the Sell by Date by pressing the number one key.



Press the Print/* key.

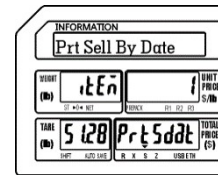
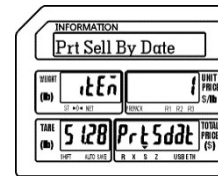

15.) Select Status of Print Sell By Time

- 0 = Don't Print Sell By Time
- 1 = Print Sell By Time

Note: The Printing of the Sell By Time on the label is controlled by this setting in each PLU.

Ex.) Select a status of Don't Print the Sell By Time by pressing the number zero key.



Press the Print/* key.

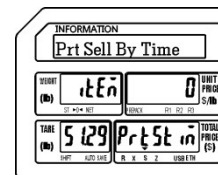
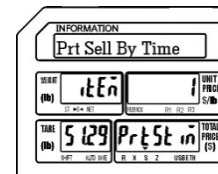

16.) Select Status of Print Pack Date

- 0 = Don't Print Pack Date
- 1 = Print Pack Date

Note: The Printing of the Pack Date on the label is controlled by this setting in each PLU.

Ex.) Select a status of Print the Pack Date by pressing the number one key.



Press the Print/* key.

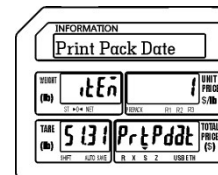
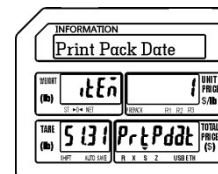
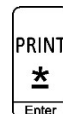

9.2.2 Programming a Non Weigh Mode PLU (S1 Mode)

17.) Select Status of Discount

0 = Disable PLU Discount

1 = Enable PLU Discount

Note: The Discount status of each PLU is controlled by this setting.

Ex.) Select a status of Enable the PLU Discount by pressing the number one key.

Press the Print/* key.

Press the SAVE key.

Press the FEED/ESC key.

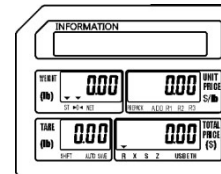
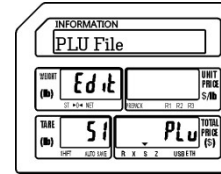
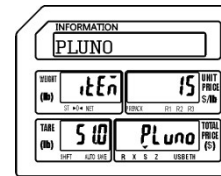
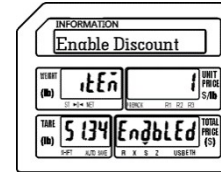
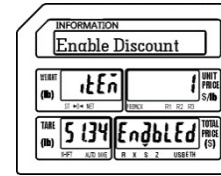
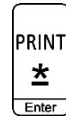

9.2.3 Programming a By Count Mode PLU (S1 Mode)

9.2.3 Programming a By Count Mode PLU (S1 Mode)

In the example below the PLU Fields that will be used have been programmed using the S Mode – PLU Fields Visible examples in the previous section.

Ex.) Create a By Count Mode PLU for Bananas that has a price of 3 for \$ 1.00.

Note: You may save the information entered at any time and exit this program by pressing the SAVE key then the FEED/ESC key. You may also exit this program without saving any entered information by pressing the FEED/ESC key at any time.

1.) Start at the normal weigh mode screen

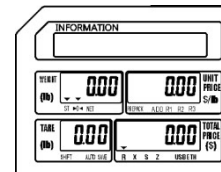

2.) Press the Mode Key twice

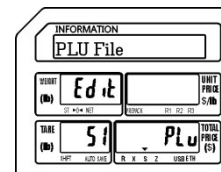

3.) Press the Print/* key

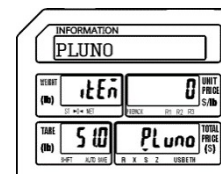

4.) Enter the PLU Number

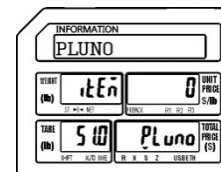

Ex.) Enter PLU Number 25 by pressing the number two key followed by the number five key.

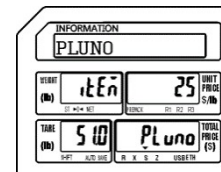

Press the Print/* key.

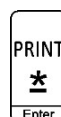

9.2.3 Programming a By Count Mode PLU (S1 Mode)

5.) Enter the PLU Name

Note: The PLU Name may be up to 4 lines of text. The number of characters printed on each line is determined by the font size of the PLU Name. The larger the font size the less characters that will be printed on each line

Ex.) Enter Bananas using the alpha keys on the programming keyboard.

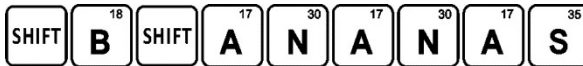

Press the Print/* key.

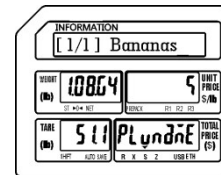
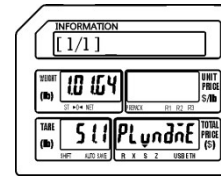
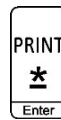

6.) Enter the Unit Price

Ex.) Enter a Unit Price of \$1.00 by pressing the number 1 key and then the number zero key twice.



Press the Print/* key.

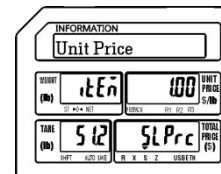
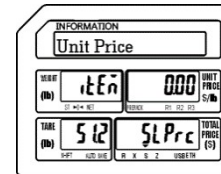

7.) Enter the PLU Type

- 0 = Weigh type
- 1 = Non Weigh type
- 2 = By Count type

Ex.) Enter 2 for By Count mode PLU Type by pressing the number two key.



Press the Print/* key.

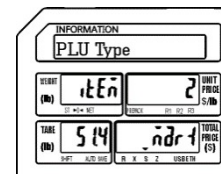
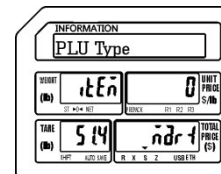

9.2.3 Programming a By Count Mode PLU (S1 Mode)

8.) Enter the Item Code

Note: The Item Code is used in the barcode to identify the PLU. It may be the same number as the PLU number or may be a different number.

Ex.) Enter an item code of 2225 using the number keys.



Press the Print/* key.

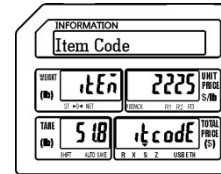
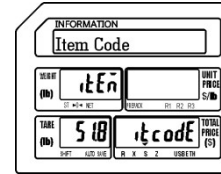
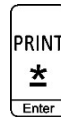

9.) Enter the Sell By Date

Note: The Sell By Date that is printed on the label is a result of adding the value (0 – 999 days) entered here to the Pack Date.

Ex.) Enter a Sell By Date of 7 days by pressing the number seven key.



Press the Print/* key.

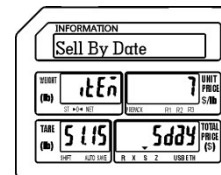
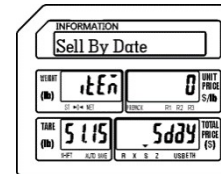

10.) Enter the Sell By Time

Note: The Sell By Time that is printed on the label is a result of adding the value (0 – 99 hours) entered here to the Pack Date.

Ex.) Enter a Sell By Time of 0 by pressing the number zero key.



Press the Print/* key.

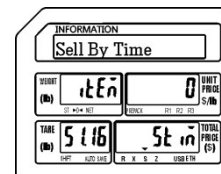
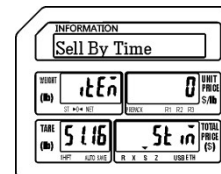
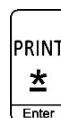

9.2.3 Programming a By Count Mode PLU (S1 Mode)

11.) Enter the Tare Weight

Note: The Tare Weight is not used in the By Count Mode.

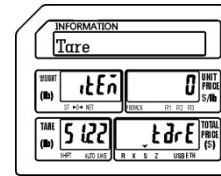

Ex.) A By Count type PLU does not use the Tare Weight field.

Press the Print/* key.



12.) Enter the Quantity

Ex.) Enter a Quantity of 3 by pressing the number three key.

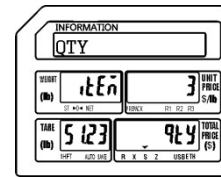
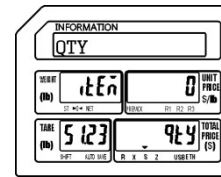

Press the Print/* key.



13.) Enter the Ingredient Message

Ex.) The example PLU Bananas, does not have any ingredients.

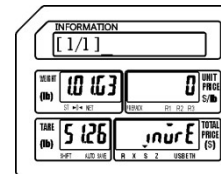

Press the Print/* key.

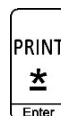

9.2.3 Programming a By Count Mode PLU (S1 Mode)

14.) Select Status of Print Sell By Date

- 0 = Don't Print Sell By Date
- 1 = Print Sell By Date

Note: The Printing of the Sell By Date on the label is controlled by this setting in each PLU.

Ex.) Select a status of Print the Sell by Date by pressing the number one key.



Press the Print/* key.

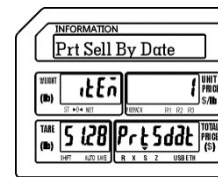
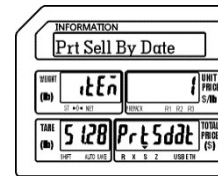

15.) Select Status of Print Sell By Time

- 0 = Don't Print Sell By Time
- 1 = Print Sell By Time

Note: The Printing of the Sell By Time on the label is controlled by this setting in each PLU.

Ex.) Select a status of Don't Print the Sell By Time by pressing the number zero key.



Press the Print/* key.

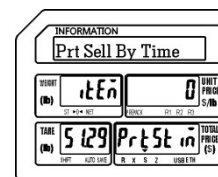
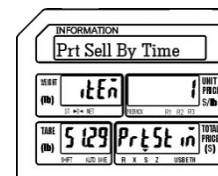
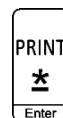

16.) Select Status of Print Pack Date

- 0 = Don't Print Pack Date
- 1 = Print Pack Date

Note: The Printing of the Pack Date on the label is controlled by this setting in each PLU.

Ex.) Select a status of Print the Pack Date by pressing the number one key.



Press the Print/* key.

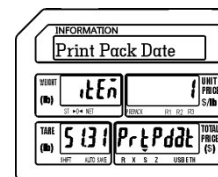
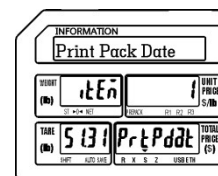
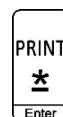

9.2.3 Programming a By Count Mode PLU (S1 Mode)

17.) Select Status of Discount

- 0 = Disable PLU Discount
- 1 = Enable PLU Discount

Note: The Discount status of each PLU is controlled by this setting.

Ex.) Select a status of Enable the PLU Discount by pressing the number one key.

Press the Print/* key.

Press the SAVE key.

Press the FEED/ESC key.

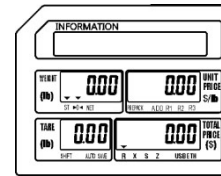
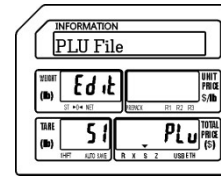
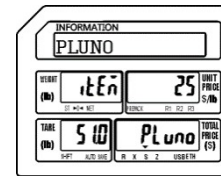
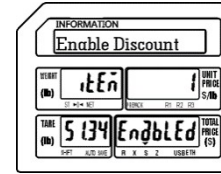
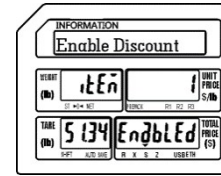
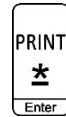

9.2.4 Deleting a PLU (S1 Mode)

9.2.4 Deleting a PLU

Follow the steps below to delete a PLU from the scale.

1.) From the PLU Number Screen

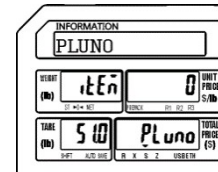

2.) Enter the PLU Number to delete

Ex.) Enter PLU Number 1 by pressing the number one key

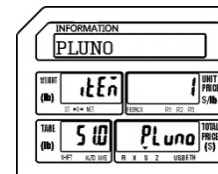

Press the VOID key

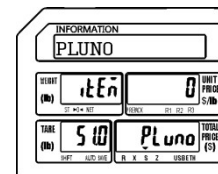

Press the FEED/ESC key

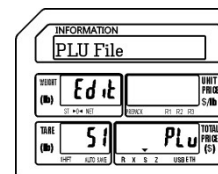

Press the FEED/ESC key.

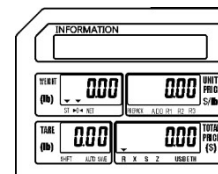

9.3 Shop Name File (S2 Mode)

9.3 Shop Name File (S2 Mode)

This programming mode allows you to enter up to 32 (1 – 32) different Shop or Store Names and Addresses. Each Shop Name can have up to 4 lines of text. Each line of text may have up to 28 characters depending on the font size and label format that is being used.

9.3.1 Entering Shop Name Information

1.) Start at the normal weigh mode screen

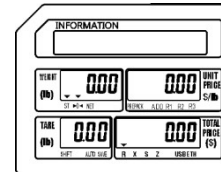

2.) Press the Mode Key twice

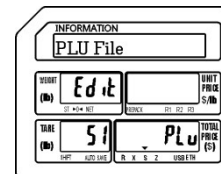

3.) Press the X key

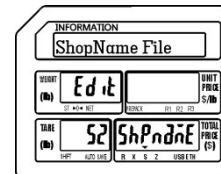

4.) Press the Print/* key

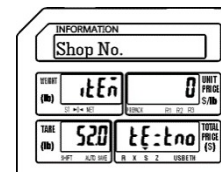

5.) Enter the Shop Number (1 – 32)

Ex.) Enter Shop Number 1 by pressing the number 1 key

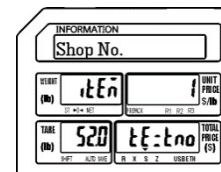

Press the Print/* key

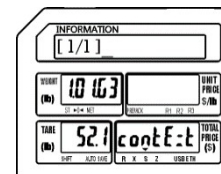

9.3.1 Entering Shop Name Information (S2 Mode)

6.) Enter First Line of Shop Information

Ex.) Store Name: Friendly Market

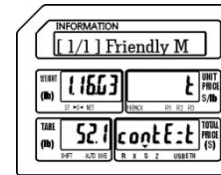
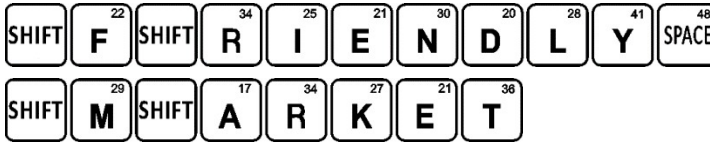

Change to the Second Line of text

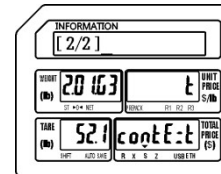

7.) Enter Second Line of Shop Information

Ex.) Store Address: 200 Main Street

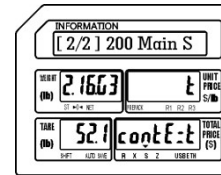

Press the Print/* key

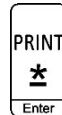

8.) Press the SAVE key

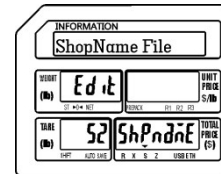

Press the FEED/ESC key.

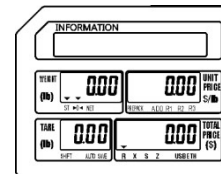

Note: Repeat the steps above as required to input all Store Information. Keep in mind that there are 4 lines of information available.

9.3.2 Deleting Shop Name Information (S2 Mode)

9.3.2 Deleting Shop Name Information

Follow the steps below to delete Shop Information from the scale.

1.) From the Shop Number Screen



2.) Enter the Shop Number to delete

Ex.) Enter Shop Number 1 by pressing the number one key

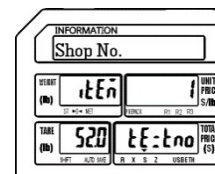

Press the Print/* key

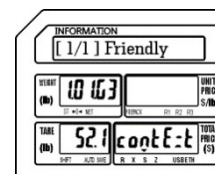

Press the VOID key

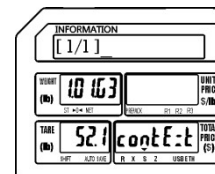

Press the FEED/ESC key

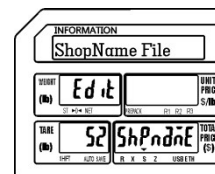

Press the FEED/ESC key.

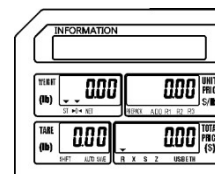

9.4 Department File (S3 Mode)

The Department File program allows you to categorize your PLU information into departments. Departments may be numbered from 1 – 99. The departments that are defined may also be assigned to groups using S Mode – S4 Main Group File.

9.4.1 Entering Department Information

1.) Start at the normal weigh mode screen

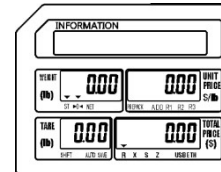

2.) Press the Mode Key twice

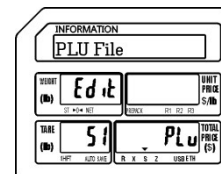

3.) Press the X key twice

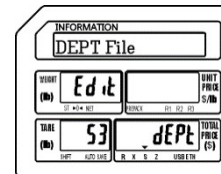
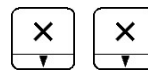

4.) Press the Print/* key

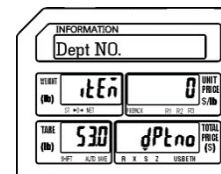
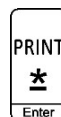

5.) Enter the Department Number (1 – 99)



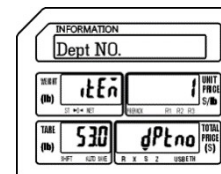



Ex.) Enter Department Number 1 by pressing the number one key

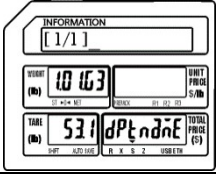
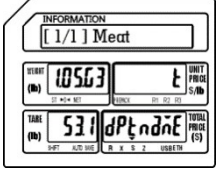

Press the Print/ key*

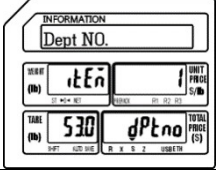

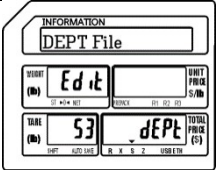
9.4 Department File (S3 Mode)

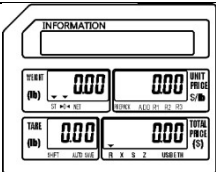
<p>6.) Enter Department Name</p>		
<p><i>Ex.) Department One Name: Meat</i></p> <p>SHIFT ²⁹M SHIFT ²¹E ¹⁷A ³⁶T</p>		
<p><i>Press the Print/* key</i></p>		
<p>7.) Press the SAVE key</p>		
<p><i>Press the FEED/ESC key</i></p>		

9.4.2 Deleting Department Information (S3 Mode)

9.4.2 Deleting Department Information

Follow the steps below to delete Shop Information from the scale.

1.) From the Department Number Screen

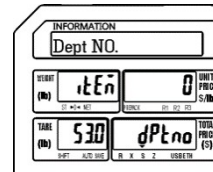

2.) Enter the Department Number

Ex.) Enter Department Number 1 by pressing the number one key

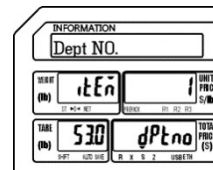

Press the Print/* key

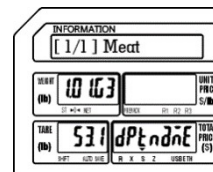

Press the VOID key

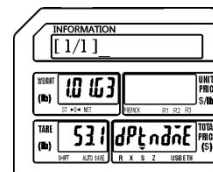

Press the FEED/ESC key

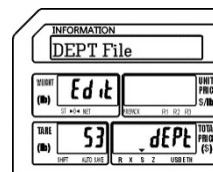

Press the FEED/ESC key

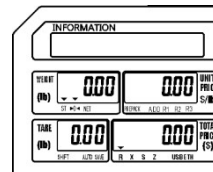

9.5 Main Group File (S4 Mode)

The Main Group File is used to further categorize the PLU information stored in the scale. Main Groups are linked to Departments and can be linked to individual or multiple scales.

9.5.1 Entering Main Group Information

1.) Start at the normal weigh mode screen

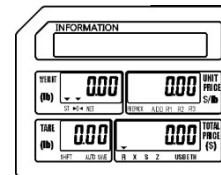

2.) Press the Mode Key twice

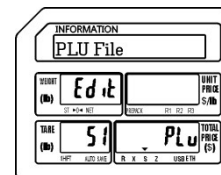

3.) Press the number four key then press the X key

Note: This has the same results as pressing the X key three times.

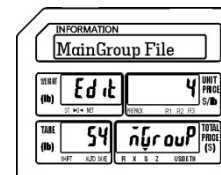

4.) Press the Print/* key

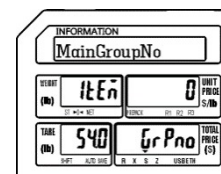

5.) Enter the Main Group Number

Ex.) Enter Main Group Number 1 by pressing the number one key

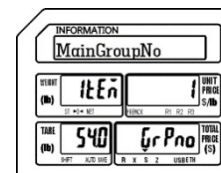

Press the Print/ key*

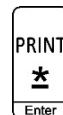

9.5.1 Entering Main Group Information (S4 Mode)

6.) Enter Main Group Name

Ex.) Main Group One Name: Beef



Press the Print/* key

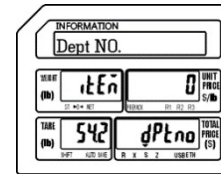
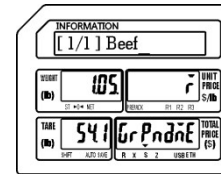
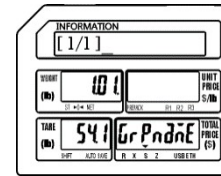

7.) Enter the Department Number

Ex.) Enter Department Number 1 by pressing the number one key

Note: This will be the Department Number that the Main Group is linked to.

Press the Print/* key

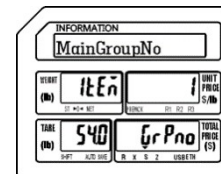
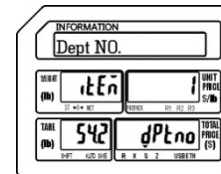
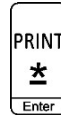

8.) Press the SAVE key

Press the FEED/ESC key

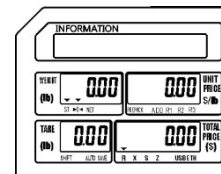
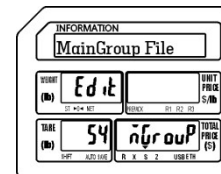

9.5.2 Deleting Main Group Information (S4 Mode)

9.5.2 Deleting Main Group Information

Follow the steps below to delete Main Group information.

1.) From the Main Group Number Screen

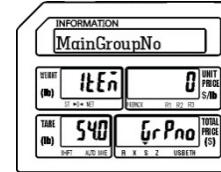

2.) Enter the Main Group Number to delete

Ex.) Enter Main Group Number 1 by pressing the number one key

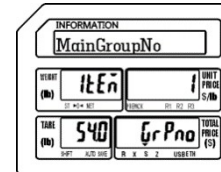

Press the Print/* key

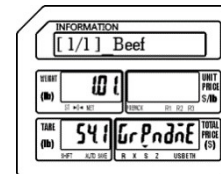
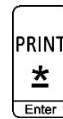

Press the VOID key

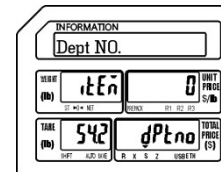

Press the FEED/ESC key

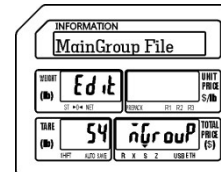

Press the FEED/ESC key

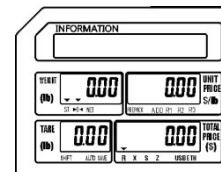

9.6 PLU Key File (S5 Mode)

9.6 PLU Key File (S5 Mode)

The PLU Key File mode is used to assign programmed PLU's to the Speed Keys. The Speed Keys are configured with 3 levels of 56 keys or a total of 168 possible Speed Keys available. Follow the steps outlined below to assign PLU's to the Speed Keys.

Note: Please keep in mind that if there is Function Key (S-Mode S6 FUNC. Key File) already assigned to a Speed Key location that location cannot have a PLU assigned to it.

The figure to the right explains the information in the display while programming PLU Speed Keys.

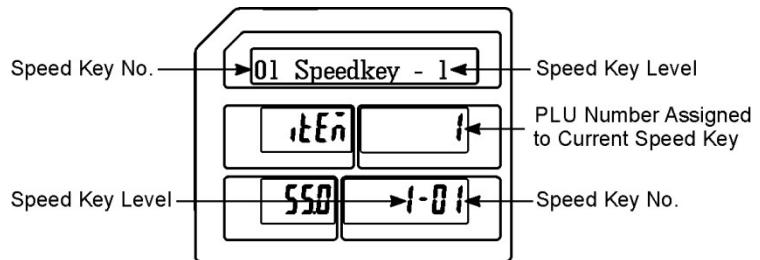

9.6.1 Programming a Speed Key on Level 1

1.) Start at the normal weigh mode screen

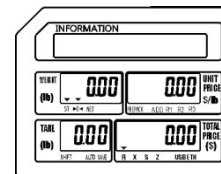

2.) Press the Mode Key twice

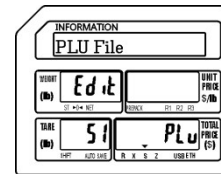

3.) Press the number five key then press the X key

Note: This has the same results as pressing the X key four times.

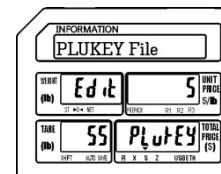

4.) Press the Print/* key

Note: Refer to the figure above for an explanation of the display.

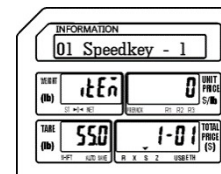

9.6.1 Programming a Speed Key on Level 1(S5 Mode)

Ex.) Assign PLU number 12 to Speed Key number 4 on Speed Key Level number 1.

5.) Enter the Speed Key Number

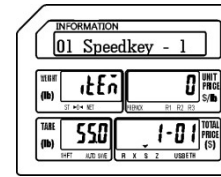

Ex.) Enter Speed Key number four by pressing the Speed Key numbered 4 one time.

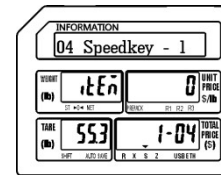

6.) Enter the PLU Number

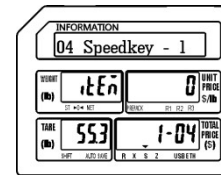

Ex.) Enter PLU number by pressing the number one key followed by the number two key.

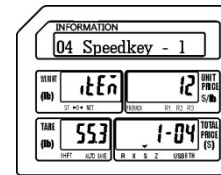

Press the SAVE key.

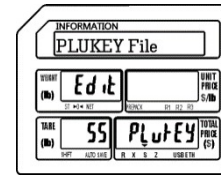

Press the FEED/ESC key

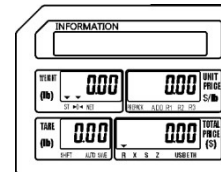

9.6.2 Programming a Speed Key Using Multiple Levels (S5 Mode)

9.6.2 Programming a Speed Key Using Multiple Levels

Ex.) Assign PLU number 12 to Speed Key number 4 on Speed Key Level number 1

Assign PLU number 18 to Speed Key number 4 on Speed Key Level number 2

Assign PLU number 25 to Speed Key number 4 on Speed Key Level number 3

1.) Start at the normal weigh mode screen

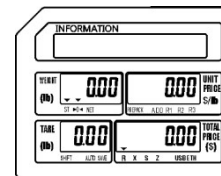

2.) Press the Mode Key twice

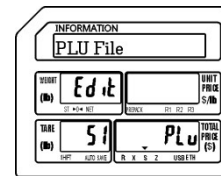

3.) Press the number five key then press the X key



Note: This has the same results as pressing the X key four times.

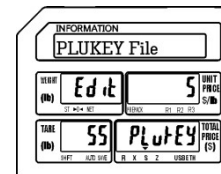

4.) Press the Print/* key



Note: Refer to the figure in Section 9.6 for an explanation of the display.

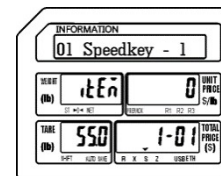

5.) Enter the Speed Key Number

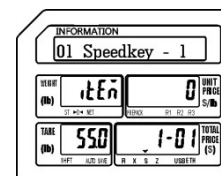

Ex.) Enter Speed Key number four by pressing the Speed Key numbered 4 one time.

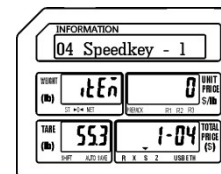

9.6.2 Programming a Speed Key Using Multiple Levels (S5 Mode)

6.) Enter the Level 1 PLU Number

Ex.) Enter Level 1 PLU number by pressing the number one key followed by the number two key.

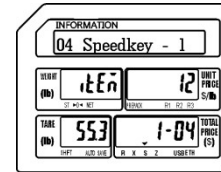
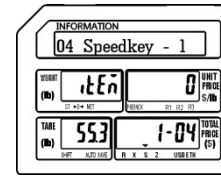

Press the SAVE key.

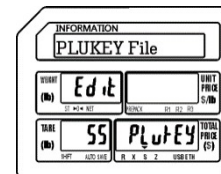

Press the Print/* key

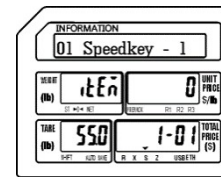
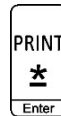

Press Speed Key number four again.

Note: Pressing Speed Key number four again selects Level 2.

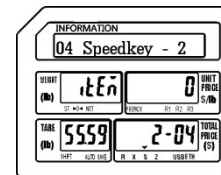

Ex.) Enter Level 2 PLU number by pressing the number one key followed by the number eight key.

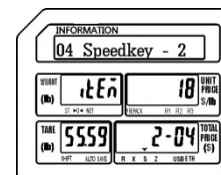

Press the SAVE key.

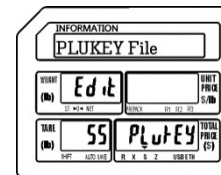

Press the Print/* key

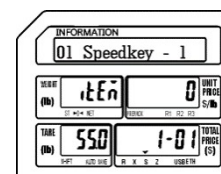

9.6.2 Programming a Speed Key Using Multiple Levels (S5 Mode)

Press Speed Key number four again.



Note: Pressing Speed Key number four again selects Level 3.

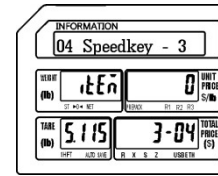

Ex.) Enter Level 3 PLU number by pressing the number two key followed by the number five key.

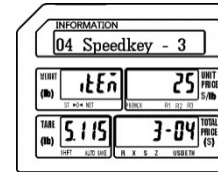

Press the SAVE key.

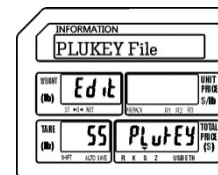

Press the FEED/ESC key

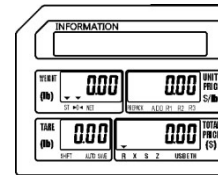

Note: The Multiple Level Speed Key programming procedure must be executed without interruption for the procedure to work as explained. If it is not executed without interruption you may have to press the Speed Key 4 twice to access the Level 2 and three times to access the Level 3 keys.

9.7 FUNC Key File (S6 Mode)

This mode is used to assign special functions to the Speed Keys. There are seven different function keys that can be assigned to any of the Speed Keys. Once a function is assigned to a Speed Key that key will no longer have multiple levels, it will only be that function.

Function Keys available are:

- Discount Amount •Discount Rate •Shop Number •Clerk Logon/Logoff
- Total Label •Subtotal Label •Label Format

9.7.1 Assigning Function Keys

Follow the procedures below to assign the special functions to the Speed Keys.

1.) Start at the normal weigh mode screen

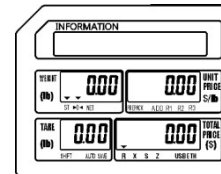

2.) Press the Mode Key twice

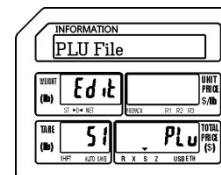

3.) Press the number six key then press the X key

Note: This has the same results as pressing the X key five times.

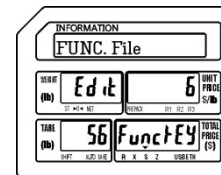

4.) Press the Print/* key

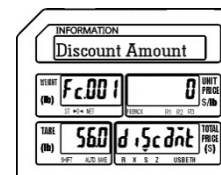

5.) Assign the Discount Amount function to a Speed Key

Ex.) Do Not Use the Discount Amount function. Enter a 0 by pressing the number zero key

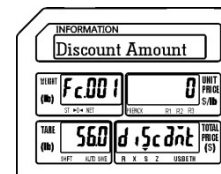

9.7 FUNC Key File (S6 Mode)

Press the Print/* key

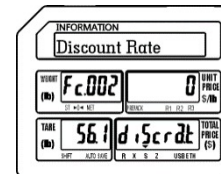

6.) Assign the Discount Rate function to a Speed Key

Ex.) Do Not Use the Discount Rate function. Enter a 0 by pressing the number zero key

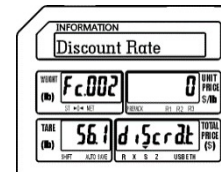

Press the Print/* key



7.) Assign the Change Shop No. function to a Speed Key

Ex.) Assign the Change Shop Number function to Speed Key number fifty five. Enter a 55 by pressing the number five key twice.



Press the Print/* key

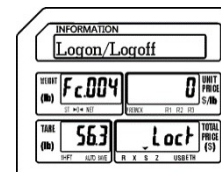

8.) Assign the Clerk Logon/Logoff function to a Speed Key

Ex.) Do Not Use the Clerk Logon/Logoff function. Enter a 0 by pressing the number zero key

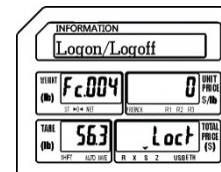

Press the Print/* key

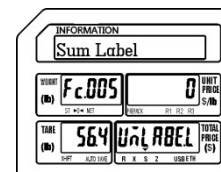

9.7 FUNC Key File (S6 Mode)

9.) Assign the Sum Label function to a Speed Key

Ex.) Do Not Use the Sum Label function.
Enter a 0 by pressing the number zero key

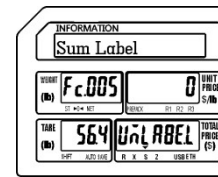

Press the Print/* key

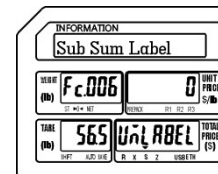
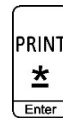

10.) Assign the Sub Sum Label function to a Speed Key

Ex.) Do Not Use the Sub Sum Label function. Enter a 0 by pressing the number zero key

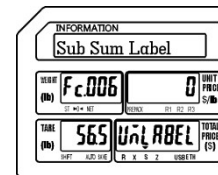

Press the Print/* key

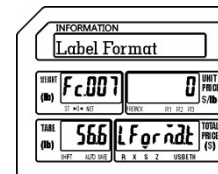
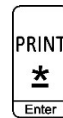

11.) Assign the Change Label Format No. function to a Speed Key

Ex.) Assign the Change Label Format Number function to Speed Key number fifty one. Enter a 51 by pressing the number five key and the number one key.

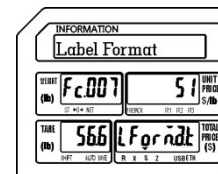

Press the Print/* key

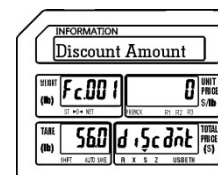
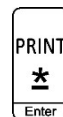

12.) Press the SAVE key

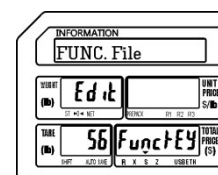

9.8 Upgrade (S7 Mode)

The Upgrade mode provides a method to update the scale's firmware version. This function is usually performed by a service technician. The new firmware file may be installed using a USB memory stick.

1.) Start at the normal weigh mode screen

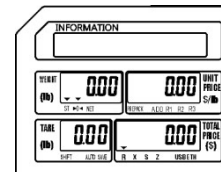

2.) Press the Mode Key twice

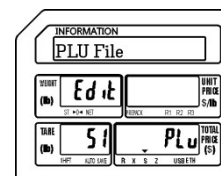

3.) Press the number seven key then press the X key

Note: This has the same results as pressing the X key six times.

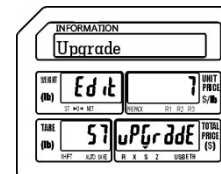

4.) Press the Print/* key

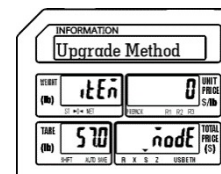

5.) Insert the USB Memory Stick

Ex.) Insert the USB memory stick with the upgrade file.

Note: USB tri mark should be lit.

Press the SAVE key.

Note S Mode tri mark will flash.

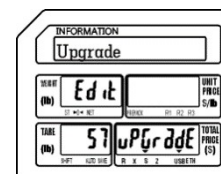

9.8 Upgrade (S7 Mode)

Screen changes to Reboot.

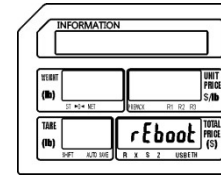

Scale reboots.

Note: During the reboot process the new firmware version should be displayed. Picture may not reflect your firmware version.

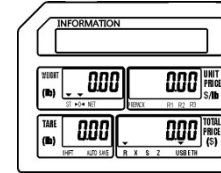
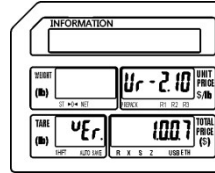

6.) Remove the USB Memory Stick.

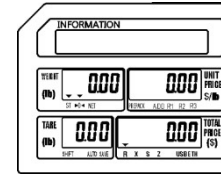

9.9 System Time File (S8 Mode)

9.9 System Time File (S8 Mode)

The System Time File is used to program the date and time in the scale. The input method must follow the scale's date and time format settings. This date and time setting is used as the reference for all other date and time functions.

1.) Start at the normal weigh mode screen

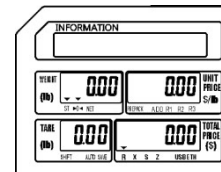

2.) Press the Mode Key twice

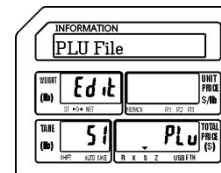

3.) Press the number eight key then press the X key



Note: This has the same results as pressing the X key seven times.

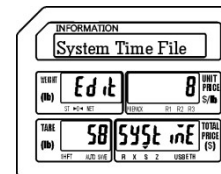

4.) Press the Print/* key

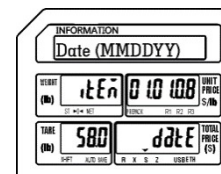

5.) Enter New Date

Ex.) Enter new date of December 8 2016 (120816) using the number keys.

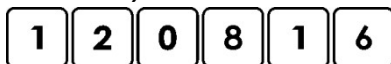

Press the Print/* key

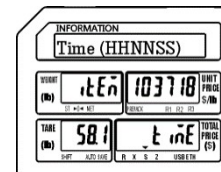

9.9 System Time File (S8 Mode)

6.) Enter New Time

Ex.) Enter new time of 10:15 AM
(101500) using the number keys.



Press the Print/* key



Press the SAVE key.



Press the FEED/ESC key.

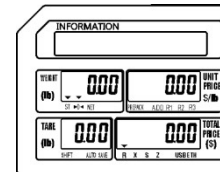
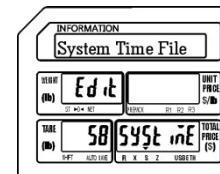
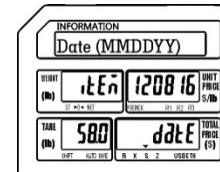
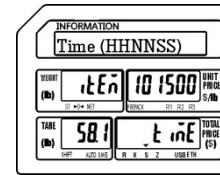

9.10 Browse System File (S9 Mode)

This mode is used to browse through the System information. It allows you to view items such as the number of PLU's, Departments and Main Groups that are programmed in the scale. You can also view the number of logos or label formats that are in the scale.

1.) Start at the normal weigh mode screen

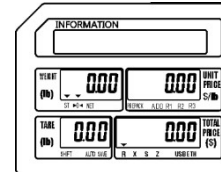

2.) Press the Mode Key twice

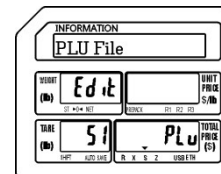

3.) Press the number 9 key then press the X key

Note: This has the same results as pressing the X key eight times.

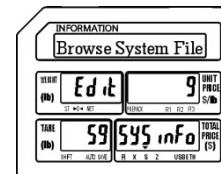

4.) Press the Print/* key



5.) Display the number of PLU's

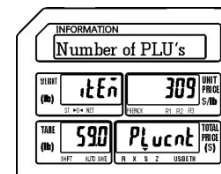

Press the Print/ key*

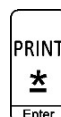

6.) Display the number of Departments

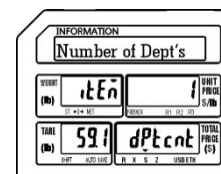

9.10 Browse System File (S9 Mode)

Press the Print/* key

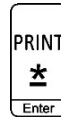

7.) Display the number of Main Groups

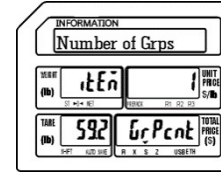

Press the Print/* key

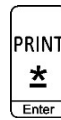

8.) Display the number of Tax Numbers

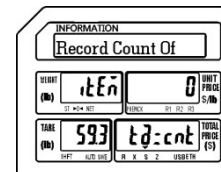

Press the Print/* key



9.) Display the number of Pictures

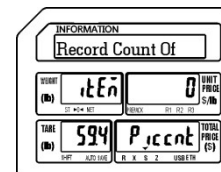

Press the Print/* key

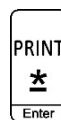

10.) Display the number of MPEG's

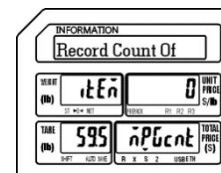

Press the Print/* key

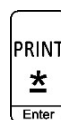

9.10 Browse System File (S9 Mode)

11.) Display the number of Bands

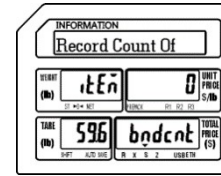

Press the Print/* key

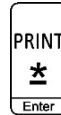

12.) Display the number of Addresses

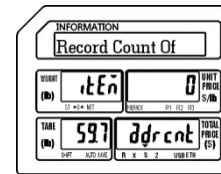

Press the Print/* key

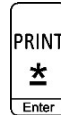

13.) Display the number of Labels

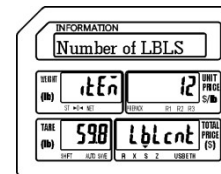

Press the Print/* key

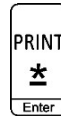

14.) Display the number of PLU D

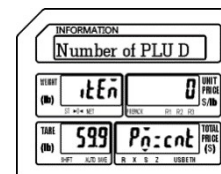

Press the Print/* key

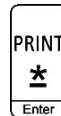

9.10 Browse System File (S9 Mode)

15.) Display the number of Logos

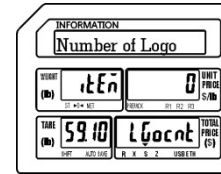

Press the Print/* key

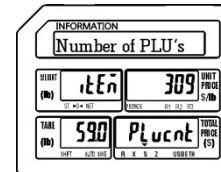
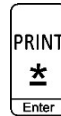

Press the FEED/ESC key

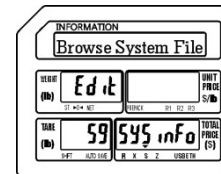

Press the FEED/ESC key.

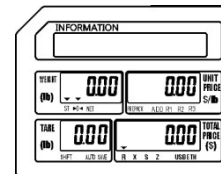

9.11 Browse CAL Record (S10 Mode)

9.11 Browse CAL Record (S10 Mode)

Using this mode allows you to view the Calibration record of the scale. Each record shows the Date and Time of the Calibration as well as the amount of weight used to Calibrate the scale during that session.

1.) Start at the normal weigh mode screen

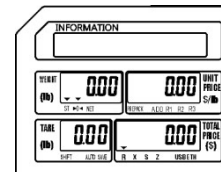

2.) Press the Mode Key twice

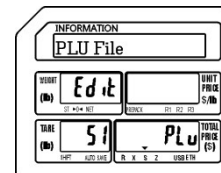

3.) Press the number 1 and then number 0 key then press the X key

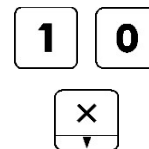

Note: This has the same results as pressing the X key nine times.

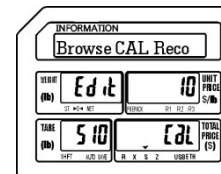

4.) Press the Print/* key



5.) Display first Calibration record

Note: Record states the scale was calibrated on November 20, 2015 at 11:59AM using 60.00 pounds.

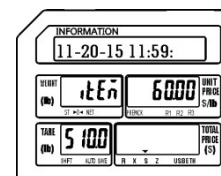

Press the Print/* key

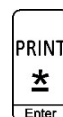

6.) Display next Calibration record

Note: Record states the scale was calibrated on November 19, 2016 at 13:16PM using 60.00 pounds.

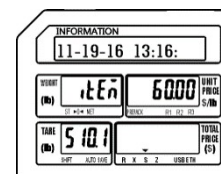

9.11 Browse CAL Record (S10 Mode)

7.) Display next Calibration record

Note: Record states the scale was calibrated on June 30, 2017 at 09:30AM using 60.00 pounds.

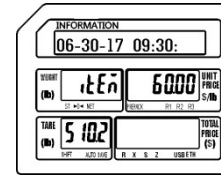

Press the Print/* key

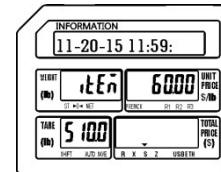
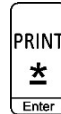

8.) Display next Calibration record

Note: This record is the first record viewed. This scale had been calibrated 3 times.

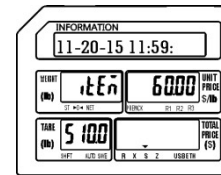

Press the FEED/ESC key

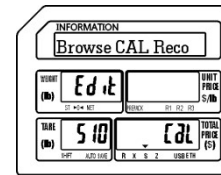

Press the FEED/ESC key.

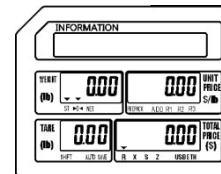

Note: *This example scale had only been calibrated three times, your scale may have several more records. The procedure to view all of them is the same as viewing these three.*

9.12 MMX – Discount Rate (S11 Mode)

9.12 MMX – Discount Rate (S11 Mode)

The MMX mode provides the ability to apply discounts to programmed PLU's. The S11 Mode allows you to discount PLU's based on a Percentage Rate. The discounts may be programmed to be active based on a date and time schedule.

9.12.1 Entering a PLU using Discount Rate

1.) Start at the normal weigh mode screen

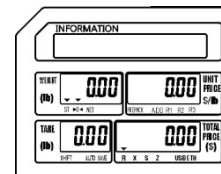

2.) Press the Mode Key twice

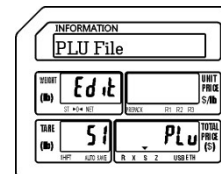

3.) Press the number 1 key twice then press the X key

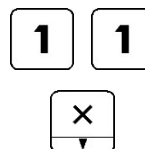

Note: This has the same results as pressing the X key ten times.

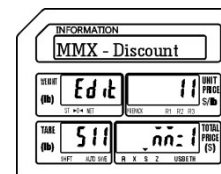

4.) Press the Print/* key

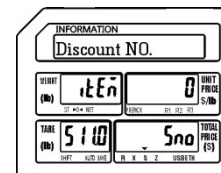

5.) Enter the Discount Number

Ex.) Enter Discount Number 1 by pressing the number one key.

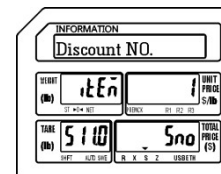

Press the Print/* key

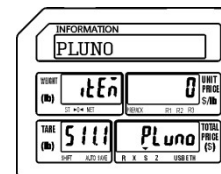

9.12.1 Entering a PLU Using Discount Rate (S11 Mode)

6.) Enter the Discounted PLU Number

Ex.) Select PLU Number 12 for Discounting by pressing the number one key and then the number two key.

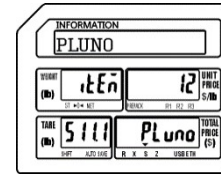

Press the Print/* key

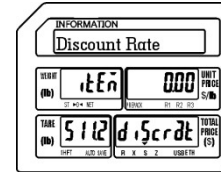
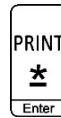

7.) Enter the Discount Rate

Ex.) Use 5% as a Discount Rate by pressing the number five key then the number zero key twice.

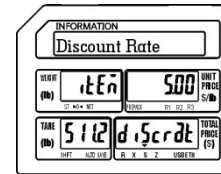

Press the Print/* key

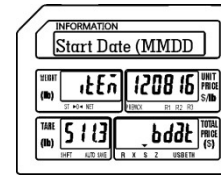
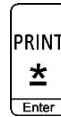

Note: The current date will be displayed. If you wish to use the current date you can just press the Print/* key again.

8.) Enter the Discount Start Date

Ex.) Enter a Start Date of December 9, 2016 (120916) using the number keys.

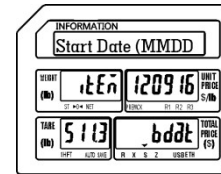
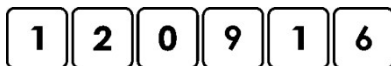

Press the Print/* key

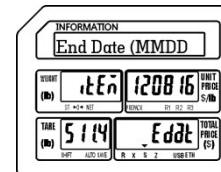

Note: The current date will be displayed. If you wish to use the current date you can just press the Print/* key again.

9.) Enter the Discount End Date

Ex.) Enter an end Date of December 15, 2016 (121516) using the number keys.

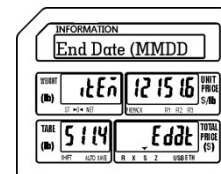

9.12.1 Entering a PLU Using Discount Rate (S11 Mode)

Press the Print/* key

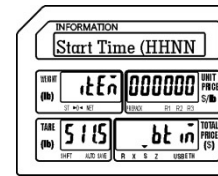
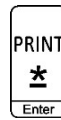

10.) Enter the Discount Start Time on each day in the date range

Ex.) Use the default Start Time of midnight. (00:00:00)

Note: To use the default Start Time simply press the Print/* key again.

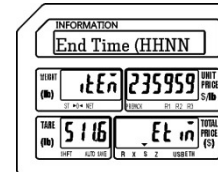

11.) Enter the Discount End Time on each day in the date range

Ex.) Use the default End Time of 11:59:59PM

Note: To use the default End Time simply press the Print/* key again.

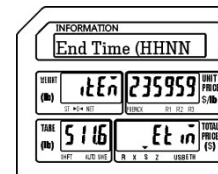

Press the SAVE key

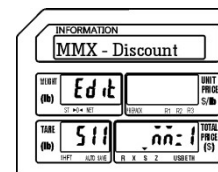

Press the FEED/ESC key.

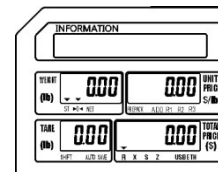

Note: After a discount has expired it must be manually deleted. Please refer to the Delete Discount procedure for the proper method to delete a discount.

9.12.2 Deleting a Discount (S11 Mode)

9.12.2 Deleting a Discount

Follow the steps below to delete a Discount.

1.) From the Discount Number Screen

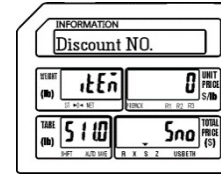

2.) Enter the Discount Number to delete

Ex.) Select Discount Number 1 to be deleted by pressing the number one key

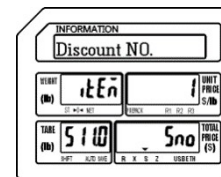

Press the VOID key

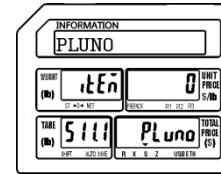

Press the FEED/ESC key

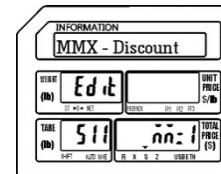

Note: Each Discount programmed can be deleted individually using the method above.

9.13 MMX – New Price (S12 Mode)

9.13 MMX –New Price (S12 Mode)

The MMX mode provides the ability to apply discounts to programmed PLU’s. The S12 Mode allows you to discount PLU’s based on a new Unit Price. This type of discount may also be programmed to be active based on a date and time schedule.

9.13.1 Entering a PLU Discount using New Price

1.) Start at the normal weigh mode screen

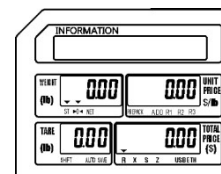

2.) Press the Mode Key twice

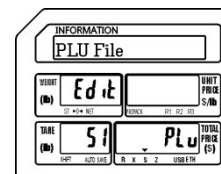

3.) Press the number 1 key then the number 2 key then press the X key

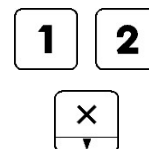

Note: This has the same results as pressing the X key eleven times.

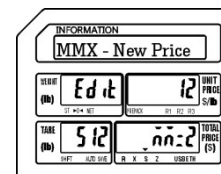

4.) Press the Print/* key

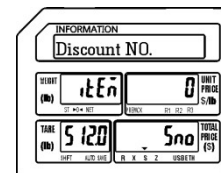
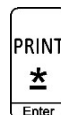

5.) Enter the Discount Number

Ex.) Enter Discount Number 5 by pressing the number five key.

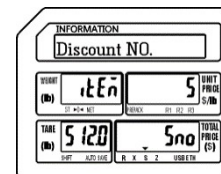

Press the Print/* key

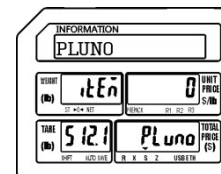
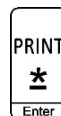

9.13.1 Entering a PLU Discount Using New Price (S12 Mode)

6.) Enter the Discounted PLU Number

Ex.) Select PLU Number 18 for Discounting by pressing the number one key then the number eight key.

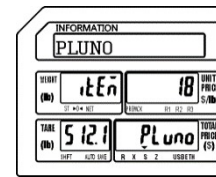

Press the Print/* key

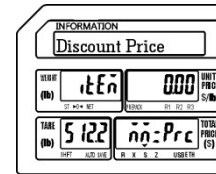

7.) Enter the New Price Discount

Ex.) Use \$7.99 as the New Price Discount by pressing the number seven key then the number nine key twice.

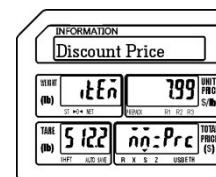

Press the Print/* key

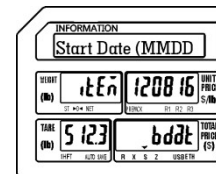
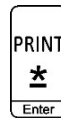

Note: The current date will be displayed. If you wish to use the current date you can just press the Print/* key again.

8.) Enter the Discount Start Date

Ex.) Enter a Start Date of December 20, 2016 (122016) using the number keys.

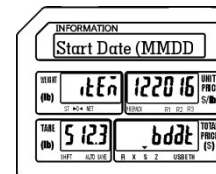
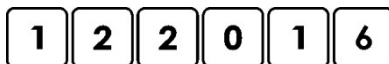

Press the Print/* key

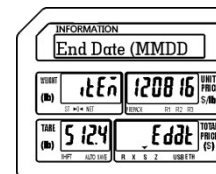

Note: The current date will be displayed. If you wish to use the current date you can just press the Print/* key again.

9.) Enter the Discount End Date

Ex.) Enter an end Date of December 27, 2016 (122716) using the number keys.

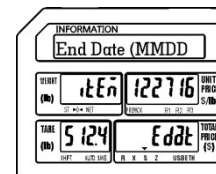
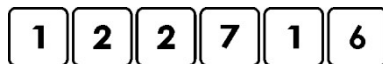

9.13.1 Entering a PLU Discount Using New Price (S12 Mode)

Press the Print/* key

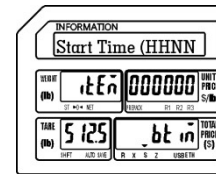
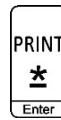

10.) Enter the Discount Start Time on each day in the date range

Ex.) Use the Start Time of 9:00AM (09:00:00)



Note: To use the default Start Time simply press the Print/* key again.

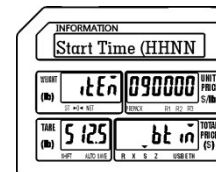

Press the Print/* key

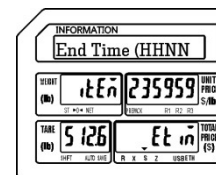

11.) Enter the Discount End Time on each day in the date range

Ex.) Use the End Time of 6:00PM

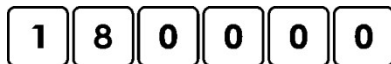

Note: To use the default End Time simply press the Print/* key again.

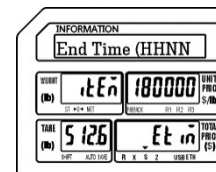

Press the Print/* key

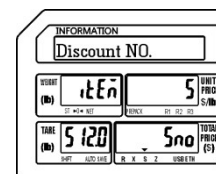
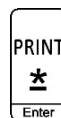

Press the SAVE key

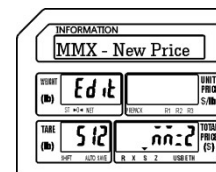

Note: After a discount has expired it must be manually deleted. Please refer to the Delete Discount procedure for the proper method to delete a discount.

9.13.2 Deleting a Discount (S12 Mode)

9.13.2 Deleting a Discount

Follow the steps below to delete a Discount.

1.) From the Discount Number Screen

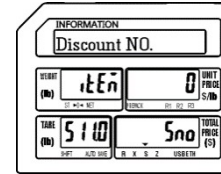

2.) Enter the Discount Number to delete

Ex.) Select Discount Number 5 to be deleted by pressing the number five key

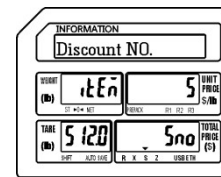

Press the VOID key

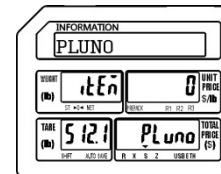

Press the FEED/ESC key

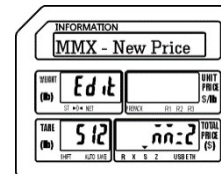

Note: Each Discount programmed can be deleted individually using the method above.

9.14 Clerk Information (S13 Mode)

9.14 Clerk Information (S13 Mode)

This mode allows you to enter Clerk Information such as Clerk No., Clerk Name and Clerk Password.

- **Note: To use the Clerk function you must assign the function key of Logon/Logoff.**

1.) Start at the normal weigh mode screen

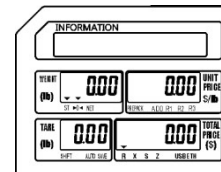

2.) Press the Mode Key twice

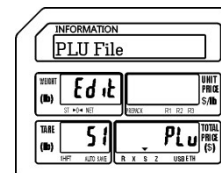

3.) Press the number 1 key then the number 3 key then press the X key

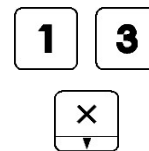

Note: This has the same results as pressing the X key twelve times.

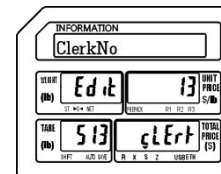

4.) Press the Print/* key

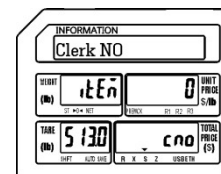

5.) Enter the Clerk Number

Ex.) Enter Clerk Number 1 by pressing the number one key.

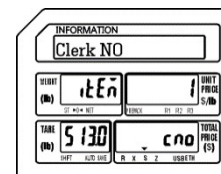

Press the Print/ key*

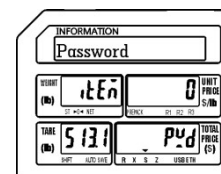
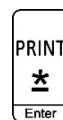

9.14 Clerk Information (S13 Mode)

6.) Enter the Clerk Password

Ex.) Enter 1537 for Clerk Number 1's password (1537) using the number keys.

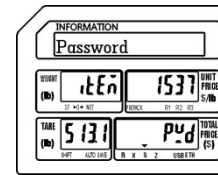

Press the Print/* key

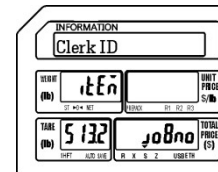
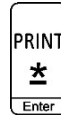

7.) Enter the Clerk Job ID Number

Ex.) Use 9 as the Clerk Job ID Number by pressing the number nine key.

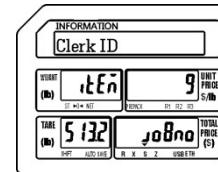

Press the Print/* key

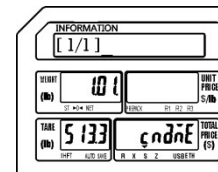

8.) Enter the Clerk Name

Ex.) Enter Clerk 1's Name as MIKE.

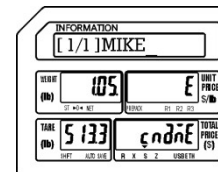

Press the Print/* key

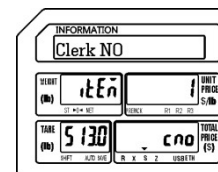
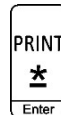

Press the SAVE key

