



Ohaus Corporation
29 Hanover Road
Florham Park NJ
07932-0900

**MOISTURE DETERMINATION
BALANCE
Model MB200**

Instruction Manual

NOTE: THIS EQUIPMENT HAS BEEN TESTED AND FOUND TO COMPLY WITH THE LIMITS FOR A CLASS A DIGITAL DEVICE, PURSUANT TO PART 15 OF THE FCC RULES.

THESE LIMITS ARE DESIGNED TO PROVIDE REASONABLE PROTECTION AGAINST HARMFUL INTERFERENCE WHEN THE EQUIPMENT IS OPERATED IN A COMMERCIAL ENVIRONMENT. THIS EQUIPMENT GENERATES, USES, AND CAN RADIATE RADIO FREQUENCY ENERGY AND, IF NOT INSTALLED AND USED IN ACCORDANCE WITH THE INSTRUCTION MANUAL, MAY CAUSE HARMFUL INTERFERENCE TO RADIO COMMUNICATIONS. OPERATION OF THIS EQUIPMENT IN A RESIDENTIAL AREA IS LIKELY TO CAUSE HARMFUL INTERFERENCE IN WHICH CASE THE USER WILL BE REQUIRED TO CORRECT THE INTERFERENCE AT HIS OWN EXPENSE.

THIS DIGITAL APPARATUS DOES NOT EXCEED THE CLASS A LIMITS FOR RADIO NOISE EMISSIONS FROM DIGITAL APPARATUS AS SET OUT IN THE INTERFERENCE-CAUSING EQUIPMENT STANDARD ENTITLED "DIGITAL APPARATUS", ICES-003 OF THE DEPARTMENT OF COMMUNICATIONS.

CET APPAREIL NUMERIQUE RESPECTE LES LIMITES DE BRUITS RADIOELECTRIQUES APPLICABLES AUX APPAREILS NUMERIQUES DE CLASSE A PRESCRITES DANS LA NORME SUR LE MATERIEL BROUILLEUR : "APPAREILS NUMERIQUES", NMB-003 EDICTEE PAR LE MINISTRE DES COMMUNICATIONS.

Unauthorized changes or modifications to this equipment are not permitted.

IN ORDER TO ENSURE COMPLIANCE WITH FCC LIMITS, INTERFACE CABLES USED WITH THIS UNIT MUST BE TRIPLE SHIELDED.

WARNING

DO NOT USE THIS PRODUCT WITH EXPLOSIVES OR COMBUSTIBLE SUBSTANCES. BECAUSE OF THE HIGH TEMPERATURES OBTAINABLE, THERE COULD BE DANGER OF IGNITION.

OHAUS CORPORATION EXPRESSLY DISCLAIMS ANY LIABILITY OR RESPONSIBILITY FOR ANY DAMAGE WHICH MAY RESULT FROM ANY USE OF THIS PRODUCT WHICH IS NOT IN ACCORD WITH THIS WARNING.

TABLE OF CONTENTS

INSTALLATION

Unpacking Instructions	5
Assembly Procedure.....	6
Platform Installation	6

GENERAL OPERATING NOTES

Locating	7
Span Calibration	8
Linearity and Span Calibration.....	9
Weighing.....	10
Taring	10
Batching (or Compounding)	11
Checkweighing	11

PRODUCT USE

Drying Curves.....	12
Normal Mode	13
Auto Dry Mode.....	15
Multi-Temp Program	18
Moisture Regain Option	20
Auto Print Option	21
Items to Print Option	22
Interval Print Option.....	22
Port Parameters Selection	23

RS232 INTERFACE

Hardware	24
Software	25

ACCESSORIES AND REPLACEMENT PARTS

TROUBLESHOOTING

SPECIFICATIONS



SERVICE INFORMATION

CARE AND MAINTENANCE

WARRANTY

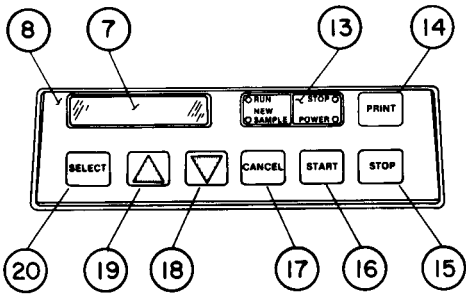
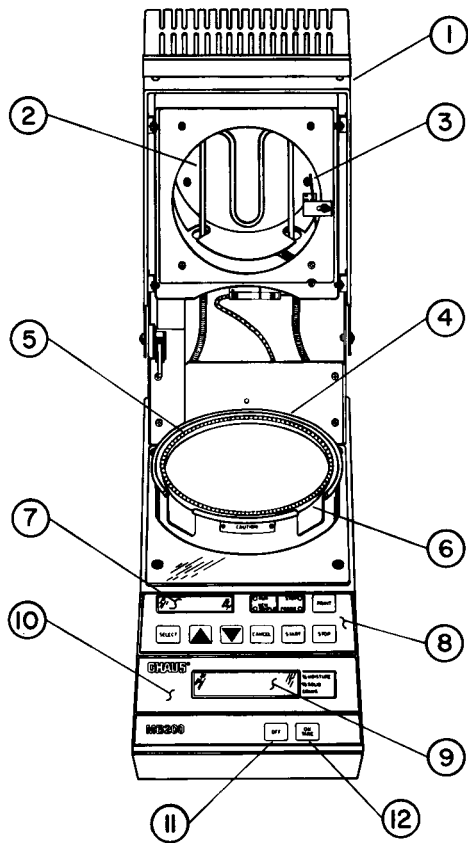
- ① DRYING HOOD
- ② HEATER UNIT
- ③ TEMPERATURE PROBE
- ④ CLEAN OUT TRAY
- ⑤ PAN LINER
- ⑥ PLATFORM
- ⑦ UPPER DISPLAY
- ⑧ UPPER CONTROL PANEL
- ⑨ LOWER DISPLAY
- ⑩ LOWER CONTROL PANEL
- ⑪ OFF BUTTON
- ⑫ ON/TARE BUTTON



- ⑬ INDICATOR LIGHT GROUP
- ⑭ PRINT BUTTON
- ⑮ STOP BUTTON
- ⑯ START BUTTON
- ⑰ CANCEL BUTTON
- ⑱ DECREASE BUTTON 
- ⑲ INCREASE BUTTON 
- ⑳ SELECT BUTTON

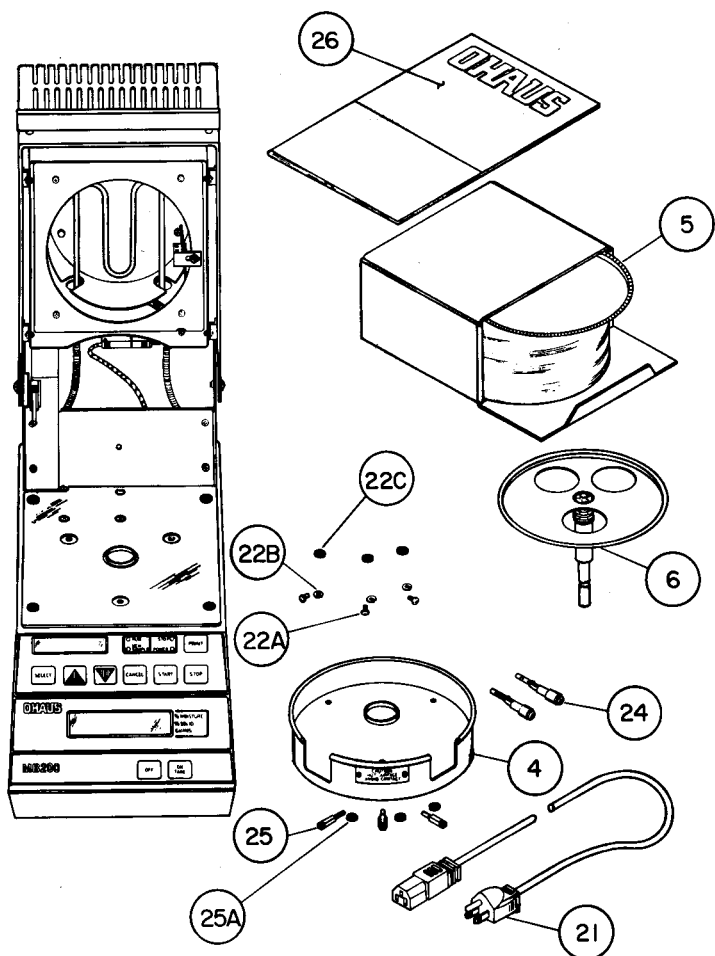

UNPACKING INSTRUCTIONS

1. Remove the POWER CORD (21), the box of PAN LINERS (5), the WARRANTY CARD and the plastic bag containing spare FUSES (24).
2. Remove the tape holding the PLATFORM (6) to the upper packing materials and remove the PLATFORM.
3. With the box sitting on a flat surface, grasp opposite edges of the upper packing materials and remove by pulling straight up.
4. Grasp the balance from the bottom and pull straight up out of the box.
5. Remove the plastic bag. Raise the HOOD (1) and remove the tape and the protective foam strip.
6. It is recommended that you save the packing material. It will be of value when storing and/or transporting your balance.

ASSEMBLY PROCEDURE

Packed along with your BALANCE please find:

- ④ CLEAN OUT TRAY
- ⑤ PAN LINERS
- ⑥ PLATFORM
- ① POWER CORD
- ②A SCREWS
- ②B LOCKWASHERS
- ②C WASHERS
- ④ FUSES
- ⑤ SPACERS
- ⑤A WASHERS
- ⑥ D&M BOOKLET

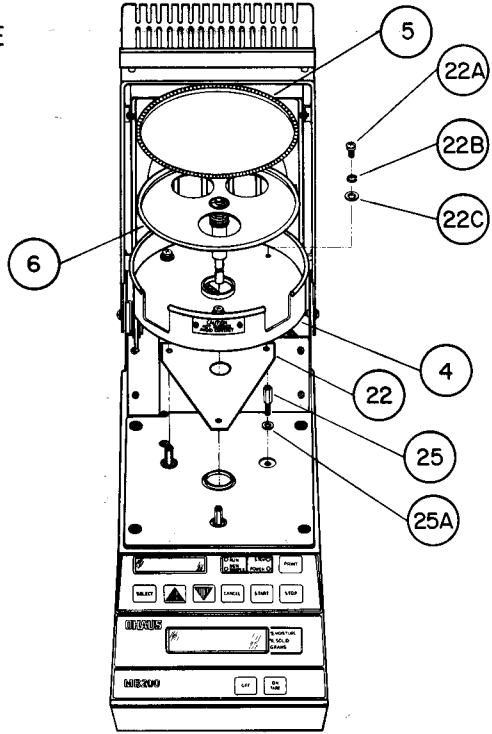





PLATFORM INSTALLATION



Follow this sequence:

- ⑤ SPACERS
- ④ CLEAN OUT TRAY
- ⑥ PLATFORM
- ⑤ PAN LINER

GENERAL OPERATING NOTES:

The programmable features of the MB200 are selectable from four basic menu steps; NORMAL MODE, AUTO DRY MODE, MULTI TEMP PRGRM, and OPTIONS. The menu step can be selected by using the  or  buttons. Desired parameters are also set by using the  or  buttons. Holding either button down will cause the values to change at a faster rate.

The  button confirms the choice displayed on the upper display and acts much like the function of choose, save or enter.

The  button erases the last choice displayed. Pressing the  button three times restores the menu and program to the power up status of NORMAL MODE.

 permits the programmed test procedure to begin.

 interrupts any test in progress and turns the heater off.

 initiates a print command to release data displayed in the lower display through the RS-232 port.

The  button turns the unit on and functions as a tare button which also functions to clear the unit of the last test results.

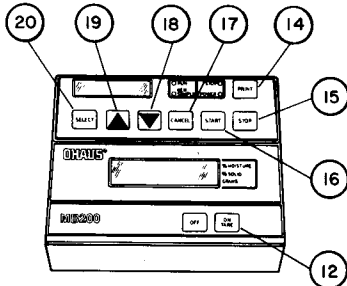

LOCATING

WARNING!
YOUR BALANCE
GENERATES
HEAT!

Operate only in an area which provides the CLEARANCES specified.

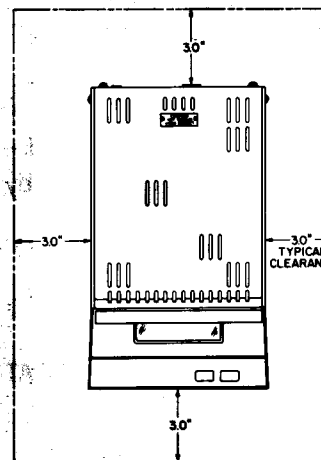
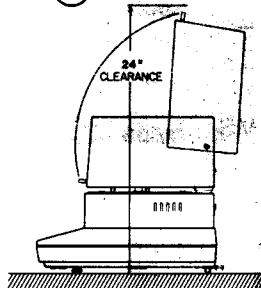

SPAN CALIBRATION

If after placing a CALIBRATED WEIGHT on the PLATFORM (6), it becomes evident that your MB200 balance needs to be calibrated again, proceed in the following manner:

1. Raise the DRYING HOOD (1), turn the balance ON (12), and allow it to warm up, with NO WEIGHT on the PLATFORM (6), FOR AT LEAST 30 MINUTES.

2. Press and hold  (12).

Release when **CAL** appears on the LOWER DISPLAY (9).

0 g will then be displayed, indicating that no weight should be on the PLATFORM (6).

3. Press  (12) again and — C — followed by

200 g will be displayed.

4. Place a 200 gram, ASTM Class 1 Tolerance CALIBRATION WEIGHT on the center of the PLATFORM (6) and close the DRYING HOOD (1).

5. Press  (12) and — C — followed by

200.00 GRAMS will be displayed.

6. Remove the CALIBRATION WEIGHT.

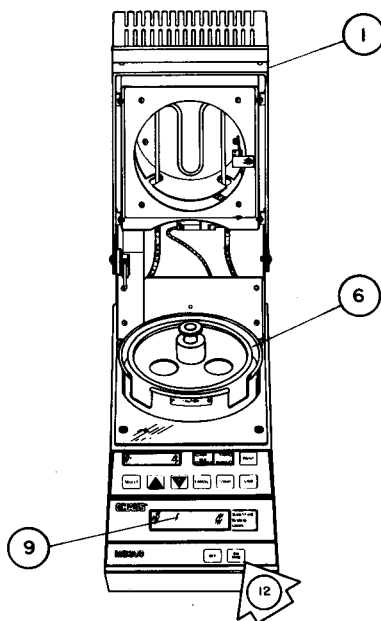

LINEARITY AND SPAN CALIBRATION PROCEDURE

1. Raise the DRYING HOOD (1), turn the balance ON (12), and allow it to warm up, with NO WEIGHT on the PLATFORM (6), for at least 30 minutes.

2. Turn the balance OFF (11).

3. Press and hold ON TARE (12).

Release when **- [** appears on the LOWER DISPLAY (9).

[0 g will be displayed, indicating that no weight should be on the PLATFORM (6).

4. Momentarily press ON TARE (12).

5. The balance will display:

[100 g

6. Place a 100 gram, ASTM Class 1 Tolerance CALIBRATION WEIGHT on the center of the PLATFORM (6) and close the DRYING HOOD (1).

7. Momentarily press ON TARE (12).

[200 g will be displayed. Remove the 100 gram CALIBRATION WEIGHT, then place a 200 gram CALIBRATION WEIGHT in the center of the PLATFORM (6), and close the DRYING HOOD (1).

8. Momentarily press ON TARE (12) again.

9. Wait until **200.00** GRAMS is displayed, which indicates that the balance is now calibrated.

10. Remove the CALIBRATION WEIGHT. Your balance is ready for weighing and moisture determination.

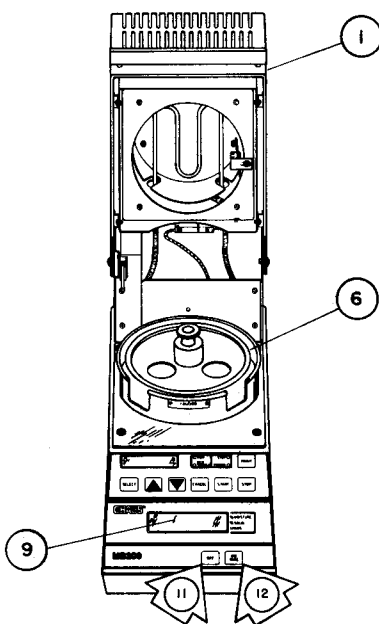



WEIGHING

1. Turn the balance ON by pressing  (12). The LOWER DISPLAY (9), will show the following for approximately three seconds:

° 1888.88 %



This indicates that all display segments are operating properly.

2. TARE the balance by pressing  (12).
3. Raise the DRYING HOOD (1) and place an unknown mass on the center of the PLATFORM (6). The weight will be displayed. The stability indicator on the LOWER DISPLAY (9) will light when reading is stable.
4. Press  (11).

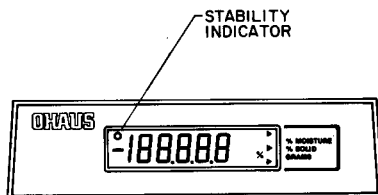
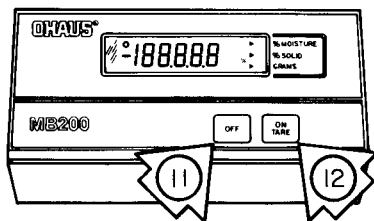
NOTE: Overload or underload will be indicated by ERROR being shown on the LOWER DISPLAY (9).



TARING

1. Press  (12) to obtain a reading of ZERO on the LOWER DISPLAY (9).
2. Raise the DRYING HOOD (1) and place an empty container on the center of the PLATFORM (6). Its weight will be displayed.
3. Press  (12) and ZERO will be displayed again. The "container weight" will be automatically subtracted from further weighings. As objects are placed in the container, only the weight of those objects will be displayed.
4. When the container and its contents are removed from the PLATFORM (6), the total "TARED" weight will be shown as a negative value on the LOWER DISPLAY (9).

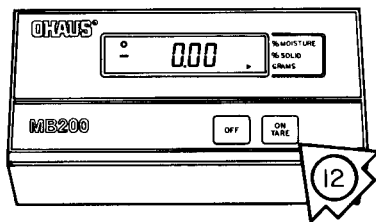

BATCHING (OR COMPOUNDING)

This procedure is actually repetitive taring. You may repeat the above procedure for each component until the capacity of the balance is reached.

CHECKWEIGHING

1. Raise the DRYING HOOD ① and place a known weight on the PLATFORM ⑥ to serve as a reference.
2. Press **ON TARE** ⑫ to obtain a zero reading.
3. Remove the known weight from the PLATFORM ⑥, and its weight will be shown as a negative value on the LOWER DISPLAY ⑨.
4. Place the other weight to be checked against the known weight on the PLATFORM ⑥.
5. If it is underweight, the difference will be displayed as a negative value. If it exceeds the known weight the difference will be displayed as a positive value.

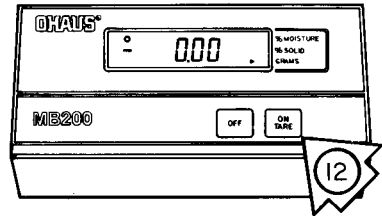

PRODUCT USE:

Normal Mode:

Use the Normal Mode to dry your sample for a specific amount of time at a selected temperature.

Auto Dry Mode:

Use the Auto Dry Mode to dry your sample until a selected rate of drying is reached. This is factory pre-set at 10 milligrams in 10 seconds.

Multi-Temp Program:

Use the Multi-Temp Program Mode to dry your sample with up to three different temperature/time periods in up to three programs, or save and recall up to three preselected drying parameters (programs). The programs

are labeled M1, M2, and M3. Each program may consist of one, two or three steps labeled M1-1, M1-2, and M1-3 for example. This function can be used to rapidly dry a very moist sample by setting a higher initial temperature for a period of time when the risk of scorching is low, then resetting the heat to a lower temperature when the risk of scorching is high.

Moisture Regain Mode:

Use the Regain Mode to obtain percent moisture based upon the dry weight according to the following formula:

$$\text{Percentage of Moisture Regained} = \frac{(\text{Wet Sample Mass} - \text{Dry Sample Mass})}{\text{Dry Sample Mass}} \times 100$$

DRYING CURVES

For the most efficient use of the balance, it is necessary to know the characteristics of the materials most frequently used. The curve shown below depicts the general drying characteristics typical of many common materials, but it will be necessary to prepare other drying curves for the materials that you are using in your specific applications.

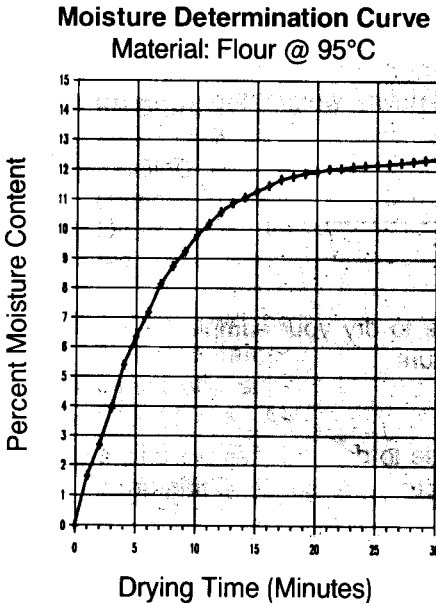

Preparation of a drying curve consists of drying a sample mass and recording the percentage of moisture loss at a predetermined time interval. In most cases, a one minute time interval is suitable. For slow drying materials, two minutes or even five minute intervals are satisfactory. Use of the Autoprint feature in the Options Menu in combination with the Auto Dry Mode and a printer or computer can aid or even automate the procedure.

If the percentage of moisture values are plotted as shown in the “Moisture Determination Curve” table, it will be obvious when the curve has reached its high point and has leveled off. At the point where the curve has leveled off, the length of time required to dry the material has been determined. For future tests, when that preset time interval is reached, the sample mass will have fully dried.

For the greatest efficiency, drying curves should be run at several different heat settings. The higher the heat, the faster the sample mass will dry. It is important to observe the sample mass after each drying test to be certain that the heat has not been set so high that the sample mass has been scorched. The best results will be obtained by a heat setting just low enough to prevent scorching, and a timer setting just slightly beyond the point where the drying curve levels off.

With the Moisture Regain Option turned off, the balance calculates percent moisture in all modes according to the following equation and is true for any sample mass within the capacity of the balance:

$$\text{Percentage of Moisture Loss} = \frac{(\text{Wet Sample Mass} - \text{Dry Sample Mass})}{\text{Wet Sample Mass}} \times 100$$

To obtain the greatest accuracy from your Moisture Determination Balance it is important to prepare a sample of at least 10 grams even though the unit will accept smaller samples. Other factors influencing accuracy are balance calibration, consistent sample preparation, and uniformity of the sample itself.

Normal Mode:

1. Upon power up your MB200 upper display will show:

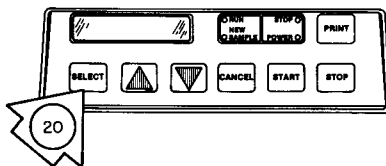

NORMAL MODE
? select

2. Press , the display shows:
SET : [] [] [] ° / [] [] [] min
? select or start



3. Press **SELECT** to change or set new parameters. The display will show:

SELECT NEW TEMP
? [] [] °C

Use the  or  to increase or decrease the temperature value. Holding the button down will cause the values to change at a faster rate. When the desired value is achieved press **SELECT**.

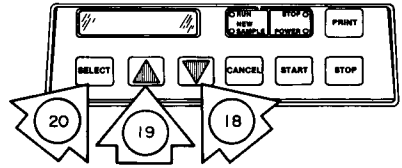

4. The display will now read:

SELECT NEW TIME
? [] [] Minutes

Select the desired value as in step 3. When the desired value is achieved press **SELECT**.

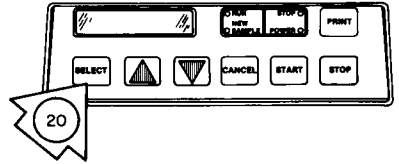

5. The display will show your settings and permit you to either start the test or edit the settings. Press **SELECT** to edit and repeat steps 3 and 4.

6. Place a pan liner on the platform and press **ON TARE**. NEW SAMPLE, STOP, and POWER indicators should all be lighted.

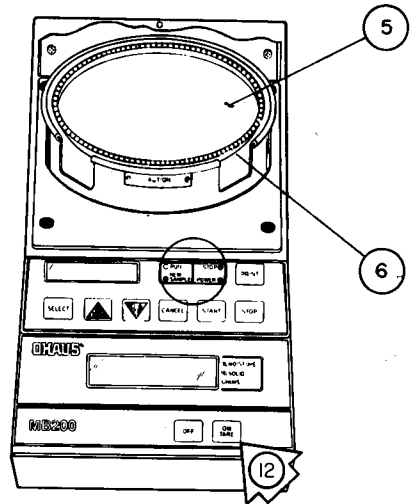

7. Raise the heater hood and place a sample of at least 10 grams on the pan liner. Lower the hood and press **START**. The test will begin immediately as indicated by the flashing RUN light. The upper display is factory set to show the set parameters, the actual temperature and elapsed time.

SET : [] [] ° / [] [] min
ACT : [] [] ° / [] [] : [] []

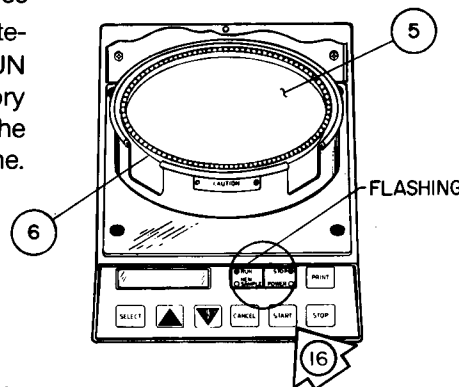



8. At the completion of the test the upper display will show:

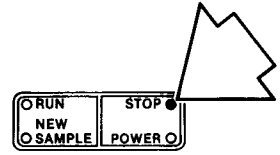

SET: [] [] [] ° / [] [] [] min
TEST COMPLETE

An audible signal will sound and the STOP indicator will be lighted.

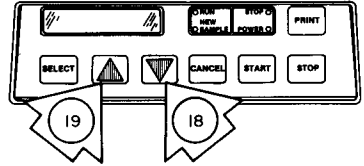

9. To display % moisture, % solid, the initial sample weight, final sample weight, or the final time and temperature, press either the  or .



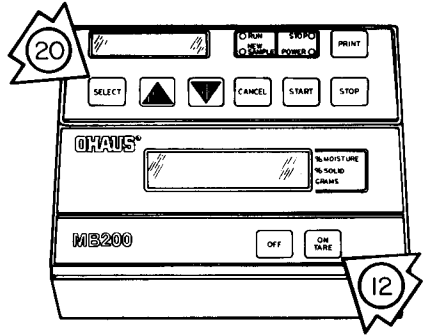

10. The lower display is factory set to show % moisture during drying tests. To transfer the % solid, or final sample weight reading from the second line of the upper display to the lower display press . This may be done any time during the test to permit monitoring both the weight and percent changes if desired. All data is maintained until the  button is pressed.



Auto Dry Mode:

1. Upon power up the unit will show:

NORMAL MODE
? select

2. Press either the  or  until the display shows:

AUTO DRY MODE
? select

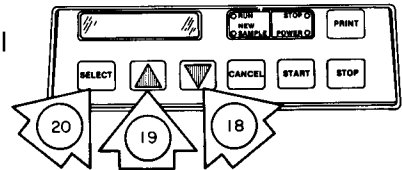



3. Press , the display will show:

A [] [] [] ° / [] [] [] g / [] [] [] s
? select or start

4. Press **SELECT** to change or set new parameters. The display will read:

SELECT TEMP (°C)
? [] [] [] ° / [] . [] [] g / [] [] s

Use the  or  to increase or decrease the temperature value. Holding the button down will cause the values to change at a faster rate. When the desired value is achieved press **SELECT**.

5. The display will now show:

SELECT DELTA (g)
? [] [] [] ° / [] . [] [] g / [] [] s

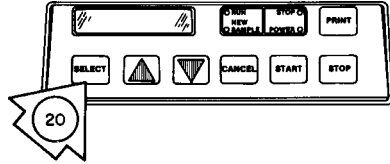

Select the desired value as in step 4. When the desired value is achieved press **SELECT**.

6. The display will now show:

SELECT TIME (SEC)
? [] [] [] ° / [] . [] [] g / [] [] s

Select the desired value as in step 4. When the desired value is achieved press **SELECT**.

7. The display will show your settings and permit you to either start the test or edit the settings. Press **SELECT** to edit and repeat steps 4, 5, and 6.

A [] [] [] ° / [] . [] [] g / [] [] s
? select or start

8. Place a pan liner on the platform and press **ON TARE**. NEW SAMPLE, STOP, and POWER indicators should all be lighted.

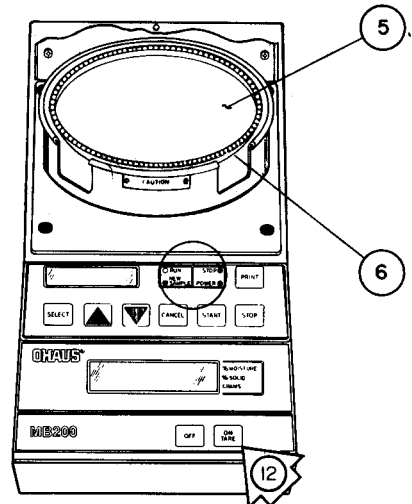

9. Raise the heater hood and place a sample of at least 10 grams on the pan liner. Lower the hood and press **START**. The test will begin immediately as indicated by the flashing RUN light.

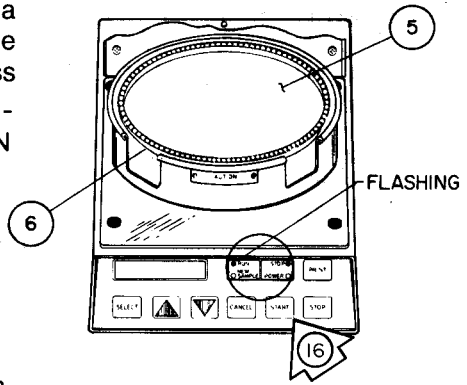

The display will show the set parameters, the actual temperature and elapsed time. There is a time limit of 180 minutes.

A [] [] [] ° / [] . [] [] g / [] [] s
 ACT: [] [] [] ° / [] [] [] : [] []

10. At the completion of the test the upper display will show:

A [] [] [] ° / [] . [] [] g / [] [] s
TEST COMPLETE

An audible signal will sound and the STOP indicator will light.

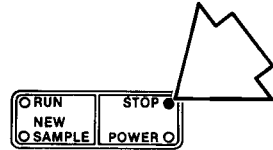

11. To display % moisture, % solid, the initial sample weight, final sample weight, or the final time and temp, press either the or .

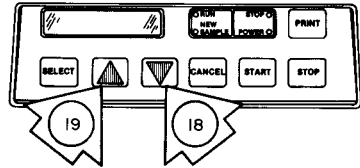

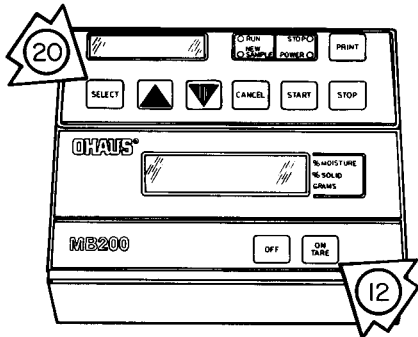

12. To transfer the % moisture, % solid, or final sample weight reading from the second line of the upper display to the lower display press **SELECT**. This may be done any time during the test to permit monitoring both the weight and percent changes if desired. All data is maintained until the **ON TARE** button is pressed.



Multi-Temp Program

1. Upon power up your MB200 upper display will show:



NORMAL MODE
? select

2. Press either the  or  until the display shows:

MULTI-TEMP PRGRM
? select

3. Press , the display will show:

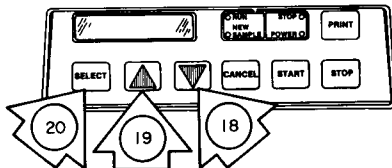

M1 [] [] [] / [] [] [] / [] [] [] °C
[] [] [] / [] [] [] / [] [] [] M

Use  or  to switch to M2 or M3 setpoints.



4. Press  to change or set new parameters. The display will show:

M1-1 CHANGE TEMP
[] [] °C [] [] min

Use the  or  to increase or decrease the temperature value. Holding the button down will cause the values to change at a faster rate. When the desired value is achieved press  .

5. The display will now show:



M1-1 CHANGE TIME
[] [] °C [] [] min

Select the desired value as in step 4 above. When the desired value is achieved press  .



6. Repeat steps 4 and 5 for each of the remaining two time and temperature intervals.

7. Upon completing the programming in steps 4 through 6 the display should show:

APPEND AUTO DRY
? yes

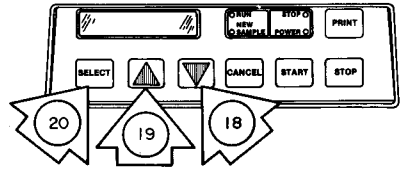
Press either  or  to select yes or no. Press  to confirm your selection. (Selecting yes will allow continued drying according to the AUTO MODE setpoints.)



8. The display will show your settings and permit you to either start the test or edit the settings. Press  to edit and repeat steps 4 through 7.
9. Place a pan liner on the platform and press . NEW SAMPLE, STOP, and POWER indicators should all be lighted.

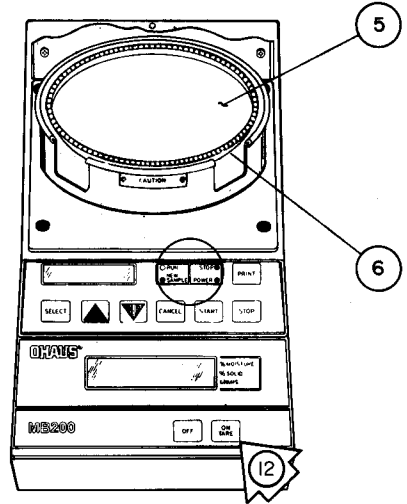



10. Raise the heater hood and place a sample of at least 10 grams on the pan liner. Lower the hood and press . The test will begin immediately as indicated by the flashing RUN light. The display will show the set parameters, the actual temperature, and elapsed time.

M1-1 : [] [] [] [] °C / [] [] [] [] M
ACT : [] [] [] [] ° / [] [] [] [] :

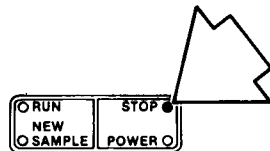
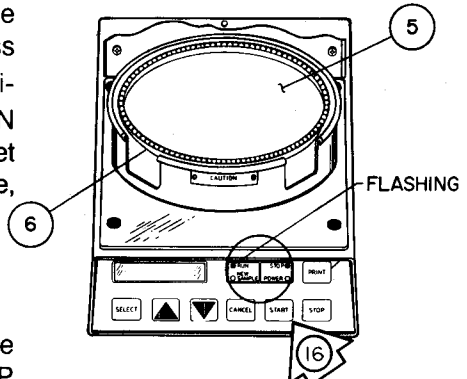

11. At the completion of the test an audible signal will sound and the STOP indicator will light. The display will show:

M1-3 : [] [] [] [] °C / [] [] [] [] M
TEST COMPLETE



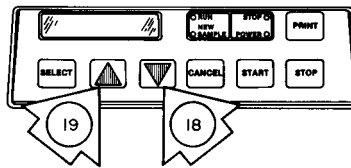

12. To display % moisture, % solid, the initial sample weight, final sample weight, or the final time and temp, press either the  or .

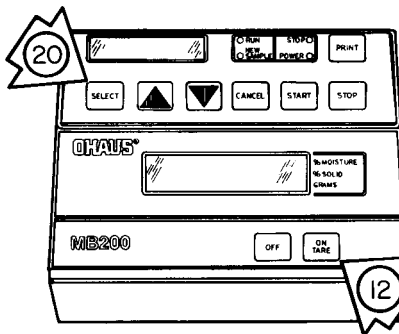

13. To transfer the % moisture, % solid, or final sample weight reading from the second line of the upper display to the lower display press . This may be done any time during the test to permit monitoring both the weight and percent changes if desired. All data is maintained until the  button is pressed.





Moisture Regain Option:

1. Upon power up your MB200 upper display will show:
2. Press either the  or  until the display shows:

NORMAL MODE
? select

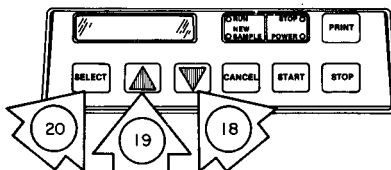

OPTIONS
? select



3. Press , the display will show:
4. Press , the display will show:

OPTIONS
? %m regain

%M REGAIN
? off

Press either  or  to select on or off. Press  to confirm your selection.

- To return to the main menu selections press **CANCEL** twice. Upon selecting any test mode, an audible signal will sound (for approximately 3 seconds) which indicates that the moisture regain mode has been activated.

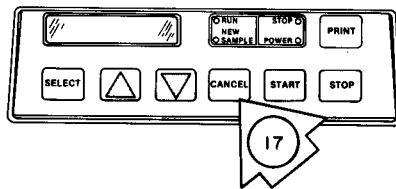

The display will show:

**%M REGAIN
ENABLED**

for approximately 3 seconds.

- Moisture determination modes employing the Moisture Regain Option are signified by the use of the % symbol in the lower display rather than the indicator arrow on at the right.

Auto Print Option:

- Upon power up your MB200 upper display will show:

**NORMAL MODE
? select**

- Press either the  or  until the display shows:

**OPTIONS
? select**

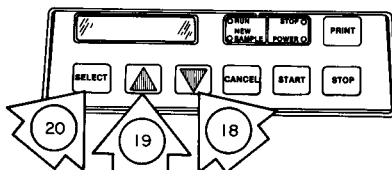

- Press **SELECT**, the display will show:



**OPTIONS
? %m regain**

- Press either the  or  until the display shows:

**OPTIONS
? auto print**

- Press **SELECT**, the display will show:

**AUTO PRINT
? off**

Press either  or  to select off, at end of test, or on intervals. Press **SELECT** to confirm your selection.



6. Upon selecting at end of test or off, the display will show:

OPTIONS
? items to print

Items to Print Option:



7. Press **SELECT**, the display will read:

ITEMS TO PRINT
TEST SETUP no ?

Press either  or  to select yes or no. Press **SELECT** to confirm your selection.

8. Repeat step 7 for each of the selectable items to print which include:

TEST SETUP	WEIGHT
% MOISTURE	TEMPERATURE
% SOLID	ELAPSED TIME

Press either  or  to select yes or no. Press **SELECT** to confirm each selection.



9. To return to the main menu selections press **CANCEL** twice or proceed to 'Port Parameters' section.

Interval Print Option:

10. Upon selecting 'on intervals' the display will show:

AUTO PRINT
? on intervals

AUTO PRINT
? every [] SECS

Press  or  to increase or decrease the time value. Holding the button down will cause the values to change at a faster rate. When the desired value is achieved press **SELECT**

11. To return to the main menu selections press **CANCEL** twice or proceed to 'Items to Print' selection.

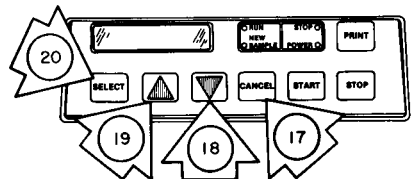
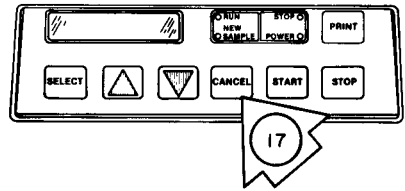
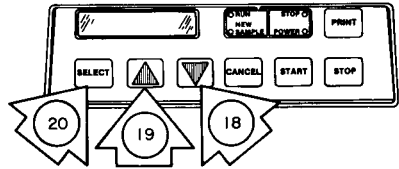

Port Parameters Selection:

1. In order to proceed with the Port parameters selection you need to know the interface requirements of the device to be connected to your MB200. These include baud rate, parity check, data bits, and stop bits.

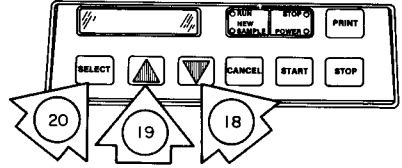



2. From the OPTIONS menu press either the  or  until the display shows:

OPTIONS
?port parameters

Press  to change port parameters.

3. The display will then show:

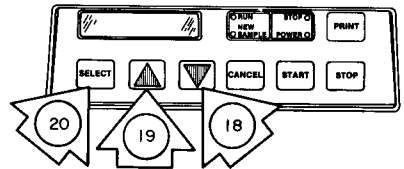

PORT PARAMETERS
BAUD RATE = [][][][]

4. Press  or  to select the desired baud rate. Rates of 300, 1200, 2400, 4800, and 9600 are available. Press  to confirm your selection.



5. The display will then show:

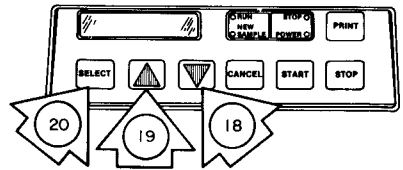

PORT PARAMETERS
PARITY CHK. = [][][][]

6. Press  or  to select the desired parity check. The choices are none, odd, or even. Press  to confirm your selection.





7. The display will then show:

PORT PARAMETERS
DATA BITS = []

8. Press  or  to select the desired data bits of either 7 or 8. Press  to confirm your selection.

9. The display will then read:

PORT PARAMETERS
STOP BITS = []

10. Press  or  to select the desired stop bits of either 1 or 2. Press  to confirm your selection.

11. To return to the main menu selections press .

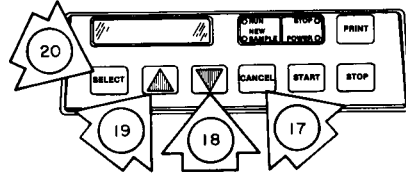

RS-232 Interface — Hardware

You can interface your balance to other equipment by means of the 9 pin subminiature "D" connector found on the back of the unit. The pinout and pin description is as shown:

- | | |
|-----------------------|-----------------------------|
| 1 - not used | 6 - DTR data terminal ready |
| 2 - TXD data out | 7 - ground |
| 3 - RXD data in | 8 - RTS request to send |
| 4 - not used | 9 - print |
| 5 - CTS clear to send | |

Threshold 0 to ± 3 volts*

*Except pin 9 — PRINT

A switch across pins 9 and 7 can be used in place of the front panel  button.

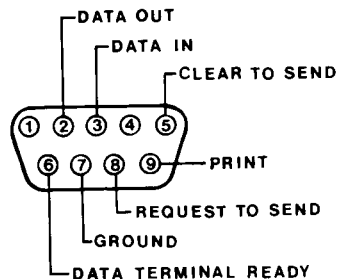

The unit will not output any information under any circumstances unless pin 5 (CTS) is held in an ON state (+3 to +15 VDC). Interfaces not utilizing the CTS handshake may tie pin 5 to pin 6 to defeat it.

NOTE: This interface does not strictly adhere to the official RS-232 standard (particularly in the connector used). However, it is compatible with what has become commonplace in the microcomputer industry.

RS-232 Interface — Software

Output Formats

	<u>OUTPUT</u>	<u>DESCRIPTION</u>
1.	Mode	'N' where N is for Normal Mode.
		'A' where A is for Auto Mode.
		'MYZ' where M is for Multi-Temp Mode. Y is the program number (1, 2 or 3). Z is the time period (1, 2 or 3).
2.	Time	'xxx m' where xxx is the setpoint time in minutes. 5 total digits
		'xxx:xx' where xxx:xx is the elapsed time in minutes and seconds. 6 total digits
3.	Temperature	'xxx C' where xxx is the temperature, either current or a setpoint, in degrees Centigrade with no decimal values. 5 total digits
4.	Weight	'xxx.xgx' where xxx.xx is weight, current, final, or sample in grams. 7 total digits (8 with minus sign)
5.	Percent	'xxx.x%y' where xxx.x is the percentage and y is either 'M' for moisture, 'S' for solid, or 'R' for regain. 7 total digits
6.	Status	'NEW' signifies that a new sample is ready for testing.
		'RUN' signifies that a test is presently running.
		'STP' signifies that a test has been stopped.
		'END' signifies that a test has ended and all final values have been saved.

NOTE: All numeric outputs feature lead zero blanking. Output strings are terminated by a carriage return-line feed combination.

RS-232 Interface — Software

Input Commands

	<u>INPUT</u>	<u>DESCRIPTION</u>														
1.	'B' <CR>	Start Test														
2.	'E' <CR>	End Test (Stop)														
3.	'T' <CR>	Tare Balance. This function is subject to the same restrictions as a tare from the front panel, i.e., no tares while a test is in progress.														
4.	'xP' <CR>	Print Command. This causes the balance to output data as specified: <table><thead><tr><th></th><th><u>Description</u></th></tr></thead><tbody><tr><td>0P</td><td>Test Setup</td></tr><tr><td>1P</td><td>Elapsed Time</td></tr><tr><td>2P</td><td>Temperature</td></tr><tr><td>3P</td><td>Weight</td></tr><tr><td>4P</td><td>% Moisture</td></tr><tr><td>5P</td><td>% Solid</td></tr></tbody></table>		<u>Description</u>	0P	Test Setup	1P	Elapsed Time	2P	Temperature	3P	Weight	4P	% Moisture	5P	% Solid
	<u>Description</u>															
0P	Test Setup															
1P	Elapsed Time															
2P	Temperature															
3P	Weight															
4P	% Moisture															
5P	% Solid															
5.	'xxS' <CR>	Select Mode and Output Setpoints <table><tbody><tr><td>_ _S</td><td>Output current mode setpoints (without changes)</td></tr><tr><td>_NS</td><td>Select Normal Mode and output setpoints</td></tr><tr><td>_AS</td><td>Select Auto Mode and output setpoints</td></tr><tr><td>1MS</td><td>Select Multitemp Program 1 and output setpoints</td></tr><tr><td>2MS</td><td>Select Multitemp Program 2 and output setpoints</td></tr><tr><td>3MS</td><td>Select Multitemp Program 3 and output setpoints</td></tr><tr><td>_MS</td><td>Select last used program and output setpoints</td></tr></tbody></table>	_ _S	Output current mode setpoints (without changes)	_NS	Select Normal Mode and output setpoints	_AS	Select Auto Mode and output setpoints	1MS	Select Multitemp Program 1 and output setpoints	2MS	Select Multitemp Program 2 and output setpoints	3MS	Select Multitemp Program 3 and output setpoints	_MS	Select last used program and output setpoints
_ _S	Output current mode setpoints (without changes)															
_NS	Select Normal Mode and output setpoints															
_AS	Select Auto Mode and output setpoints															
1MS	Select Multitemp Program 1 and output setpoints															
2MS	Select Multitemp Program 2 and output setpoints															
3MS	Select Multitemp Program 3 and output setpoints															
_MS	Select last used program and output setpoints															
6.	'C' <CR>	Output current status of balance, where <ol style="list-style-type: none">First line of output indicates the current state, ie. NEW, RUN, STP or END.Second line of output lists the setpoints of the current modes.Third line of output lists the current weight if the status is 'NEW', otherwise, elapsed time, current temperature, current weight, % moisture, and % solid.														

NOTE: <CR> indicates carriage return. A carriage return-line feed combination is also acceptable. Spaces (indicated by “_”) are optional.

RS-232 Interface — Software

Test Setup Commands

<u>MODE</u>	<u>INPUT</u>	<u>DESCRIPTION</u>
1. Normal Mode	'xxx_yyy_N' <CR> (7 digits min.)	'xxx' Setpoint temperature in Centigrade. 'yyy' Setpoint time in minutes.
2. Auto Mode	'xxx_y.yy_zz A' <CR> (10 digits min.)	'xxx' Setpoint temperature in Centigrade. 'yy' Setpoint change in weight (delta) in grams. 'zz' Setpoint change in time (delta) in seconds (must be multiples of 10)
3. MultiTemp Mode	'aaa_bbb_x_yz_M' <CR> (10 digits)	'aaa' Setpoint temperature for program 'yz'. 'bbb' Setpoint time for program 'yz'. 'x' 1 to append auto mode, 0 to end normally. 'yz' y is the program number, 1-3 available. z is the period in the program, 1-3 available.

NOTE: Entries must contain the equivalent number of characters in the field as shown.

ACCESSORIES AND REPLACEMENT PARTS

Accessory

	Ohaus
	<u>Part Number</u>
Span Calibration Weight - 200g ASTM Class 1 Tolerance	49025-11
Linearity Calibration Weight - 100g ASTM Class 1 Tolerance	49015-11
Service Manual	9755-34
Security Locking Cable	76288-00
Below balance Hook	76790-00
Pan Liners (package of 100)	6081-00
Data Printer	AS023-01
Shielded I/O Cable Assembly for Data Printer	AS017-20
Pads (box of 400)	77597-01

Replacement Parts

	Ohaus
	<u>Part Number</u>
Power Cord, 120 V ac - U.S.	6569-00
Power Cord, 220 V ac - European	76212-00
Power Cord, 240 V ac - European	76448-00
Power Cord, Universal Australian	76199-01

Fuses (all slow blow)

100/120 V ac - 5 Amperes	90360-15
100/120 V ac - 1/2 Ampere	96360-05
220/240 V ac - 2 1/2 Amperes	90360-12
220/240 V ac - 3/8 Ampere	90360-04

TROUBLESHOOTING

Before assuming that your Ohaus MB200 is faulty, check through the following troubleshooting list. These simple corrective actions may eliminate a call to your service representative.

SYMPTOM	PROBABLE CAUSE(S)	REMEDY
DISPLAY WILL NOT LIGHT	1. Power cord not connected	Connect power cord.
	2. Fuse blown	Unplug the balance. Check the voltage setting and replace fuse with one of the proper size. If fuse still fails, contact service representative.
BALANCE DISPLAYS ERROR SIGNAL	1. Pan missing from balance	Replace pan.
	2. Balance capacity exceeded	Reduce the amount of weight to less than range capacity.
	3. Balance calibrated incorrectly	Calibrate balance using correct weights and proper procedure.
UNSTABLE WEIGHT READINGS	1. Hostile environment	Protect balance from environment.
	2. Pan movement obstructed	Inspect and correct.
UNSTABLE TEMPERATURE READINGS	1. Thermocouple disconnected	Connect thermocouple.
	2. Heater hood disturbed during test	Do not raise hood during test.

SPECIFICATIONS

Capacity (g)	200
Readability (g) [%]	0.01/0.1
Taring Range	To Capacity
Taring Time	1 Second
Precision (Std Dev) (g)	± 0.007
Linearity (g)	± 0.01
Stabilization Time	2.5 Seconds
Moisture Range (%)	0-100 (0-999 to regain Mode)
Timer	0-180 Minutes
Temperature Settings	35°C to 205°C by 1°C
Temperature Variation* - typ	$\pm 1^\circ\text{C}$
Heat Source	Infrared
Interface	RS-232 Bi-directional
Baud Rate	300, 1200, 2400, 4800, 9600
Weight (net/gross) [lb]	12.5/18
Dimensions (L×W×H)	12.75"×7.5"×10.75"
Operating Temperature Range	10°C-40°C
Power Requirements	120 VAC, 50/60 Hz
Also available	100, 220, 240 VAC, 50/60 Hz

*Temperature variation reading is taken at sensor after stabilization.

SERVICE INFORMATION

If your electronic balance needs maintenance, and/or repair, you can be assured of the best and fastest service available by calling the Ohaus Product Service Department for return information. A Product Service Specialist will be able to provide advise on packing, shipping instructions, local service availability, turnaround time, etc. Failure to call may cause delays.

For Electronic Balance Service assistance, please call Ohaus Corporation toll-free at (800) 526-0659.

In New Jersey call 201-377-9000.

CARE AND MAINTENANCE

To keep your balance operating properly, the cover, housing, drying hood and removable pan should be kept clean and free from foreign materials.

UNPLUG THE BALANCE before cleaning. DO NOT USE CHEMICALS OF ANY KIND on the cover or housing, because they may damage the displays windows. If necessary, a damp cloth with a mild, non-abrasive detergent may be used. Be careful not to scratch the display windows and do not allow any liquid to flow inside the balance. Wipe the balance dry with a soft cloth.

LIMITED WARRANTY

Ohaus products are warranted against defects in materials and workmanship from the date of delivery through the duration of the warranty period. During the warranty period Ohaus will repair, or, at its option, replace any component(s) that proves to be defective at no charge, provided that the product is returned, freight prepaid, to Ohaus.

This warranty does not apply if the product has been damaged by accident or misuse, exposed to radioactive or corrosive materials, has foreign material penetrating to the inside of the product, or as a result of service or modification by other than Ohaus. In lieu of a properly returned warranty registration card, the warranty period shall begin on the date of shipment to the authorized dealer. No other express or implied warranty is given by Ohaus Corporation. Ohaus Corporation shall not be liable for any consequential damages.

As warranty legislation differs from state to state and country to country, please contact Ohaus or your local Ohaus dealer for further details.



11

Ohaus Corporation
29 Hanover Road,
Florham Park, NJ 07932, USA
Tel: (201) 377-9000,
Fax: (201) 593-0359

Ohaus Europe Ltd.
ENGLAND
Tel: +44 (0) 1954 251343,
Fax: +44 (0) 1954 250205

With offices in Germany, France, Spain, Italy, Canada, Mexico and Japan.



Ohaus Corporation
29 Hanover Road
Florham Park NJ
07932-0900

The pages you are about to
view are for an accessory
which is no longer available

June 8, 2000



Security Device Accessory

~~P/N 76288-00~~

OBSOLETE, NO LONGER AVAILABLE

Installation Instructions

The Security Device accessory kit is designed to protect OHAUS® balances against theft. Before installing this accessory, carefully read these instructions. If assistance is needed, contact Ohaus Corporation:

- In the U.S., call toll-free at 1-800-526-0659.
- In New Jersey, call 1-201-377-9000.

INSTALLATION

Figure 1 shows the typical lock and cable assembly for balances requiring the Security Device Bushing to be installed in the balance.

WARNING: ALWAYS DISCONNECT POWER BEFORE OPENING BALANCE.

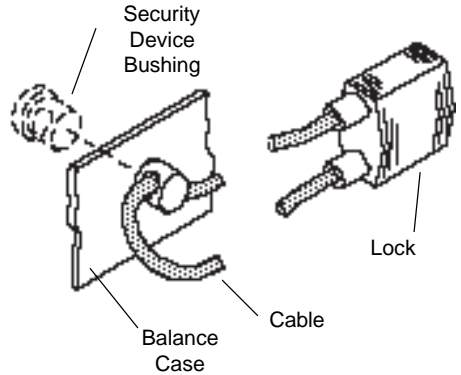
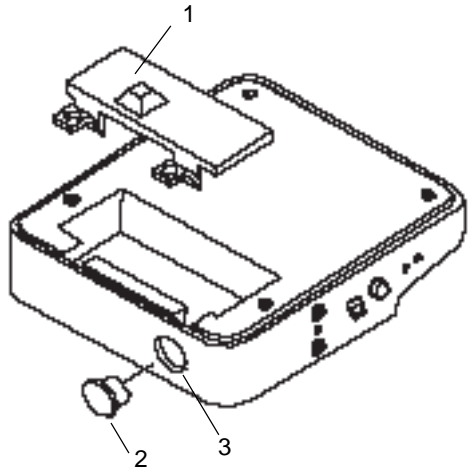

Figure 1

CT Series, C305, C505 and S200

1. Remove Battery Cover and Battery Pack.
2. Remove Hole Plug.
3. Install Security Device Bushing in hole and install Lock and Cable as in Figure 1.
4. Reassemble.



Port-O-Gram Balances

1. Remove screws which secure Battery Cover. Remove cover and battery pack.
2. Remove Hole Plug.
3. Install Security Device Bushing in hole and install Lock and Cable as in Figure 1.
4. Reassemble.

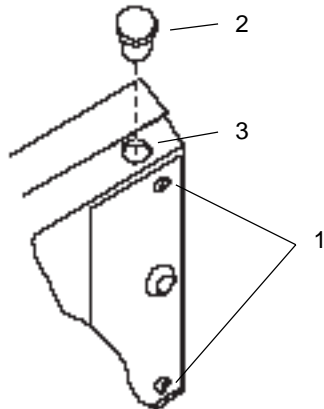

E Series, Galaxy, GT400, GT4000 and GT8000 Only

1. Remove screws and washers which secure cover to base and lift the cover. Be careful not to pull any wires, cables or connectors going from the cover to the base.
2. Remove Hole Plug.
3. Install Security Device Bushing in hole and install Lock and Cable as in Figure 1.
4. Reassemble.

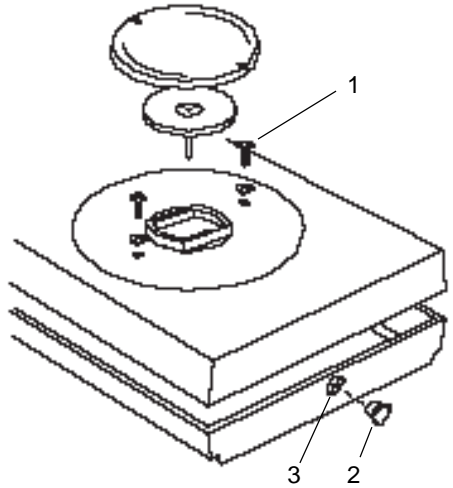

PRECISION *Standard* Balances

1. Remove the Draft Shield (if installed), Pan and Pan Support.
2. Remove the three screws which secure cover to base and lift cover off.
3. Remove Hole Plug.
4. Install Security Device Bushing in hole and install Lock and Cable as in Figure 1.
5. Reassemble.

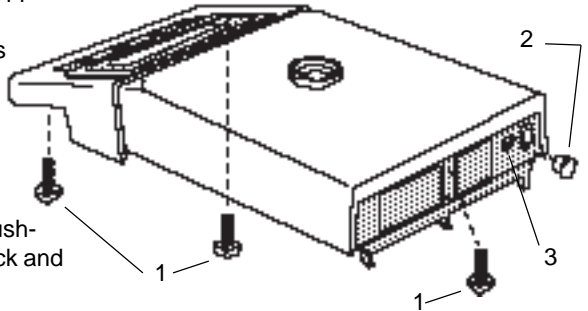

MB200, PRECISION *Plus* and All GT Series Except GT400, GT4000 and GT8000

The Security Device Bushing is not required on these balances.

To install, simply pass the Cable through the hole in the level indicator on the rear of the balance.

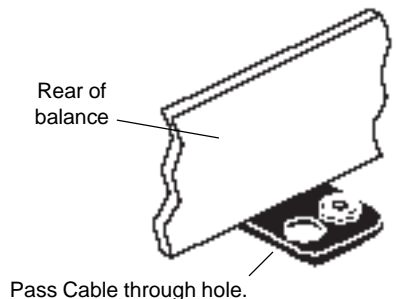

MB 300, MB301 and B Series Balances

The Security Device Bushing is not required on these balances.

To install, simply pass the Cable through the hole in the pad between two heat sink fins on the rear of the balance.

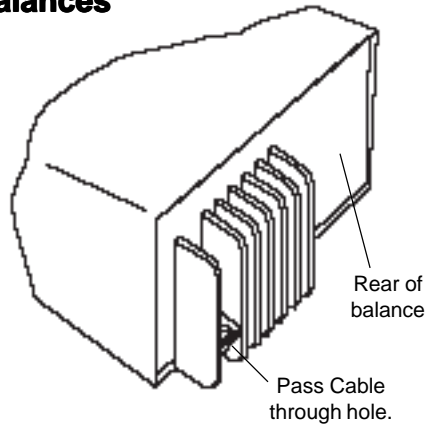

Other Balances

The Security Device may be used with other balances however, a 1/2" diameter hole may need to be drilled in the balance to accept the Security Device Bushing. If so, the following precautions must be taken:

PRECAUTIONS

- Select a location on the balance where drilling will not damage any internal components.
- If uncertain, contact balance manufacturer for recommendations.
- Make sure that chips caused by drilling do not get into the mechanism of the balance.
- Verify that operation of balance will not be obstructed when Security Device Bushing is installed in the balance.

OHAUS® is the registered trademark of Ohaus Corporation as are the following trademarks: CENT-O-GRAM®, CHECK-O-GRAM®, DEC-O-GRAM®, DIAL-O-GRAM®, PRIMER®, 5-0-5®, and 10-10®.

OHAUS CORPORATION

P.O. Box 900
29 Hanover Road
Florham Park, N.J. 07932, USA
Tel: 201-377-9000
Telex: 6853191 OHAUS UW
Fax: 201-593-0359

With other offices in England, Mexico, Canada,
Japan, Germany, France, Switzerland

OHAUS®