

AD-4407A

OP-03/05/07/08

WEIGHING INDICATOR

INSTRUCTION MANUAL



1WMPD4002032

This Manual and Warning Definitions

The warnings described in this manual have the following meanings:

CAUTION	Disregarding the caution could result in loss of important data or damage to the instrument
Note	Provides information useful for the user to operate the instrument.

 This is a hazard alert mark.

© 2012 A&D Company, Limited. All rights reserved.

No part of this publication may be reproduced, transmitted, transcribed, or translated into any language in any form by any means without the written permission of A&D Company, Limited.

The contents of this manual and the specifications of the instrument covered by this manual are subject to change for improvement without notice.



Contents

1. Compliance.....	3
1.1. Compliance with FCC Rules.....	3
1.2. Compliance with European Directives	3
2. Introduction.....	4
3. Installation and Precautions.....	5
3.1. Installation and Precautions	5
3.2. Load Cell Connections	5
3.3. Adjustment of the Load Cell Output.....	6
3.4. Verifying Load Cell Output and Input Sensitivity.....	6
3.5. Installing an Option board.....	7
4. Description of Panels and Symbols	8
4.1. Front Panel Description	8
4.2. Rear Panel Description.....	9
4.3. Other Displays and Symbols	10
4.4. Accessories and Options.....	10
5. Calibration	11
5.1. Items of Calibration Mode.....	11
5.2. Calibration Procedure.....	12
5.2.1. Configuring a Weighing Instrument	12
5.2.2. To Get Stabilized Data	14
5.2.3. Zero Calibration.....	15
5.2.4. Span Calibration.....	15
5.2.5. Exiting the Calibration Mode.....	16
5.3. Weighing Range Function	17
5.3.1. Selecting the Division and Range.....	18
5.4. Digital Linearization Function	18
5.5. Gravity Compensation Function	19
5.5.1. Gravity Acceleration Table	20
5.6. Calibration Error Code List	21
6. Functions	22
6.1. Changing the Function Settings.....	22
6.2. F-Functions	23
6.3. CF-Functions.....	30
7. Tare.....	31
7.1. Weighing Tare	31
7.2. Digital Input	31
7.3. Clearing Tare.....	31

8.	Accumulation	32
8.1.	Preparation and Specification	32
8.2.	Display and Operation	33
9.	Code Memory	34
9.1.	Using Code Memory	35
10.	Comparison	36
10.1.	Weight Check Mode	36
10.1.1.	Condition Formula for Comparison.....	37
10.1.2.	Setting the Upper/Lower Limit Values	37
10.2.	Setpoint Comparison	39
10.2.1.	Description of Input Parameters and Outputs.....	39
10.2.2.	Simple Batch	40
10.2.3.	Setting the Parameters of Setpoint Comparison	41
11.	Hold Function.....	42
11.1.	Setting the Hold Functions.....	42
12.	Counting Function.....	44
12.1.	Using the Counting Function	44
12.2.	Unit Weight Registration	44
13.	RS-232C Interface (OP-05, OP-08)	46
13.1.	Specification	46
13.2.	Data Format.....	47
13.3.	Command Format.....	47
13.3.1.	Command to Request Data	48
13.3.2.	Commands to Control the Indicator	49
13.3.3.	Commands to Set Parameters	51
13.3.4.	Commands for Hold Function	52
13.3.5.	Commands to Set Serial Data Output Format (UFC)	52
13.4.	UFC Command.....	53
14.	RS-422/RS-485, Relay Output(OP-03)	55
15.	Relay Output and Control Input (OP-05).....	57
16.	4-20mA Analog Output (OP-07).....	58
17.	Current Loop Output (OP-08)	59
18.	Specifications.....	61
18.1.	Dimensions.....	62



1. Compliance



1.1. Compliance with FCC Rules

Please note that this equipment generates, uses and can radiate radio frequency energy. This equipment has been tested and has been found to comply with the limits of a Class A computing device pursuant to Subpart J of Part 15 of FCC rules. These rules are designed to provide reasonable protection against interference when this equipment is operated in a commercial environment. If this unit is operated in a residential area it may cause some interference and under these circumstances the user would be required to take, at his own expense, whatever measures are necessary to eliminate the interference.

(FCC = Federal Communications Commission in the U.S.A.)



1.2. Compliance with European Directives



This appliance complies with the statutory EMC (Electromagnetic Compatibility) directive 89/336/EEC and the Low Voltage Directive 73/23/EEC for safety of electrical equipment designed for certain voltages.

Note: The displayed value may be adversely affected under extreme electromagnetic influences.



2. Introduction

- The AD-4407A is a weighing indicator that amplifies the signal from a load cell, converts it to digital data and displays it as a mass value.
- This indicator has the following performance:
 - Input sensitivity: 0.15 μ V/division.
 - Maximum display: 40000 divisions.
 - Refresh rate of the display: . 10 times/second approximately.
 - Input voltage range: -35 mV ~ +35 mV.
- The following standard functions are available:
 - The HiHi / Hi / OK / Lo / LoLo limit comparison to check a mass value.
 - The setpoint comparison for batching applications.
 - The counting function for piece counting.
 - The preset tare function.
 - Four code memories to store the above mentioned data.
 - The accumulation function to totalize the mass values and to count the number of accumulations.
 - The hold function enables weighing a living animal.
 - UFC (Universal Flex Coms) function to customize the protocol of outputting data using the serial interface.
 - **0** - **9** keys enables easy operation, such as specifying comparator values.
 - IP-65 dust & water-proof stainless housing.
- The following interfaces are available as options:

One interface can be installed in the indicator at a time.

 - OP-03: RS-422/485 and 3-Relay Outputs
 - OP-05: RS-232C, 3-Relay Outputs and 3-Control Inputs
 - OP-07: Analog Output (4-20mA)
 - OP-08: RS-232C, Current Loop Output, 3-Relay Outputs and 1-Control Input
- The calibration function includes the following functions:
 - Setting the minimum division (weighing interval) and the maximum capacity.
 - Zero and span calibration.
 - The weighing range function of the multi-interval weighing instrument (scale).
 - Digital linearization function.
 - Gravity compensation function.



3. Installation and Precautions



3.1. Installation and Precautions

- The weighing indicator is a precision electronic instrument. Handle it carefully.
- The operating temperature is -10°C to +40°C (14°F to 104°F).
- Do not install the scale in direct sunlight.
- Mis-operation or other problems may be caused by an unstable power source including momentary power failure or instantaneous noise. Use a stable power source.
- ⚠ □ Do not connect the power cord before the installation has been completed.
- ⚠ □ Verify that the local voltage and receptacle type are correct for your indicator.
- Use shielded cables for all connections. Connect the cable shields to the shield terminal or case as an earth terminal.
- Earth ground the indicator. Do not share the earth ground line with other electrical power equipment. (Example: There is an earth ground terminal at the power cord receptacle.)
- Do not install the indicator in a place where it is apt to be charged with static electricity, or where the relative humidity is lower than 45%RH. Plastic and insulating materials are apt to be charged with static electricity.
- Even if the display is turned off, the power is on while the power cord is connected to the AC power source.
- Even if the indicator complies with IP-65, do not immerse the indicator in water.
- To maintain water-proof performance, tighten the cable clamp firmly when connecting the load cell cable or interface cable. And tighten the bolts on the rear panel firmly.



3.2. Load Cell Connections

- Connect the load cell cable to the terminal as shown below.
- It is possible to connect a 4 wire cable provided that pins 1-2 and pins 3-4 are connected, if the distance between the indicator and a load cell is shorter than 5m. At this time, use a cable with a wire having a cross-sectional area of 0.5 mm² or greater because thin cables will decrease the temperature coefficient.
- The output voltage of a load cell is a very sensitive signal. Space the load cell cable away from any noise source.
- It is possible to connect eight 350ohm load cells.
The load cell drive is 5VDC ± 5% between EXC+ and EXC-, the maximum current 120mA.

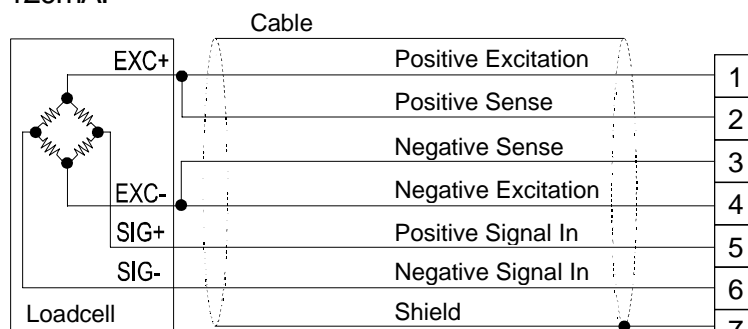

Standard connection

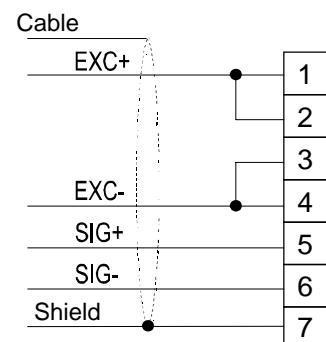

Connection available for a cable shorter than 5m.
(Recommended wire cross-sectional area: 0.5 mm² or greater)



3.3. Adjustment of the Load Cell Output

Caution □ When adding a resistor to adjust a load cell output, use a metal film resistor in the range of 50kohm to 500kohm with a good temperature coefficient. Use as large of a resistance value as possible in the range in which the zero adjustment is possible. Solder this resistor at a point near the load cell or the indicator.

In Case of Reducing the Output Voltage

When the zero output is too large, add a resistor between EXC+ and SIG-.

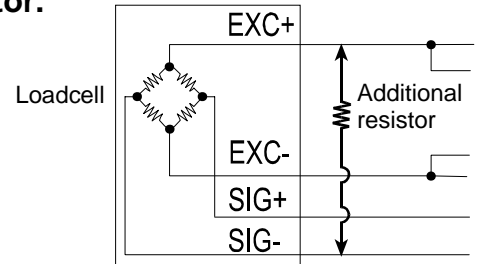

In Case of Adding an Offset Voltage to the Output

When the zero output is too small, add a resistor between EXC+ and SIG+.

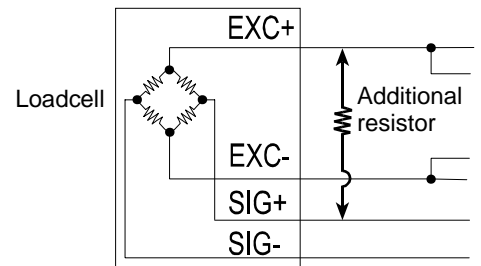

3.4. Verifying Load Cell Output and Input Sensitivity

The input sensitivity of the indicator is 0.15 μV/division or more. Satisfy the following inequality, when you design a weighing instrument using the indicator and load cell(s).

Caution □ A change in input voltage sensitivity is required to cause a one division change of the display. Select as large an input sensitivity voltage as possible so that the weighing interval becomes stable.
 □ Consider the leverage if a lever is used.

Weighing instrument using one load cell.	$0.15 \leq \frac{E * B * D}{A}$	A: Rated capacity of load cell [kg] B: Rated output [mV/V] D: Weighing interval [kg]
Weighing instrument using multi-load cell	$0.15 \leq \frac{E * B * D}{A * N}$	E: Excitation voltage [mV] N: Number of load cells

Verification Example

Design:		
Load cell	N=1	
Rated capacity	A=750 [kg]	$\frac{5000 * 3 * 0.05}{750} = 1 \geq 0.15$ <p>Therefore, regard the instrument as a good design.</p>
Rated output	B=3 [mV/V]	
Excitation voltage	E=5000 [mV]	
Weighing interval	D=0.05 [kg]	
Weighing capacity	300 [kg]	



3.5. Installing an Option board

Caution □ Do not remove any screws other than described below.

Install an interface (OP-03, OP-05, OP-07 or OP-08) as follows:

- Step 1 Remove the power cord from the AC power source.
- Step 2 Remove eight hex bolts (one of them is the sealing bolt) from the rear panel.
- Step 3 Remove the rear panel carefully as there are cables between the front panel unit and the rear panel.
- Step 4 Place the option board on the option board installation area in the rear panel and secure it with screws.
- Step 5 Connect the option board and the main board in the front panel unit, using the option cable.
 - OP-03 (RS-422/485, Relay output) J2 - Main board J2
J3 - Main board J5
 - OP-05 (RS-232C, I/O) J5 - Main board J5
 - OP-07 (4-20mA Analog output) J2 - Main board J2
J5 - Main board J5
 - OP-08 (RS-232C, current loop output, I/O) J5 - Main board J5
- Step 6 Pass the interface cable through the cable clamp to the external equipment.
- Step 7 Connect the interface cable to the option board connector or terminal block.
- Step 8 Place the rear panel on the front panel unit, and secure it using the bolts removed in Step 2.
- Step 9 After powered on, enter the F-functions and store the F30 parameter, depending on the option.
 - OP-03, OP-05 and OP-08: Serial output
 - OP-07: Analog output



4. Description of Panels and Symbols



4.1. Front Panel Description

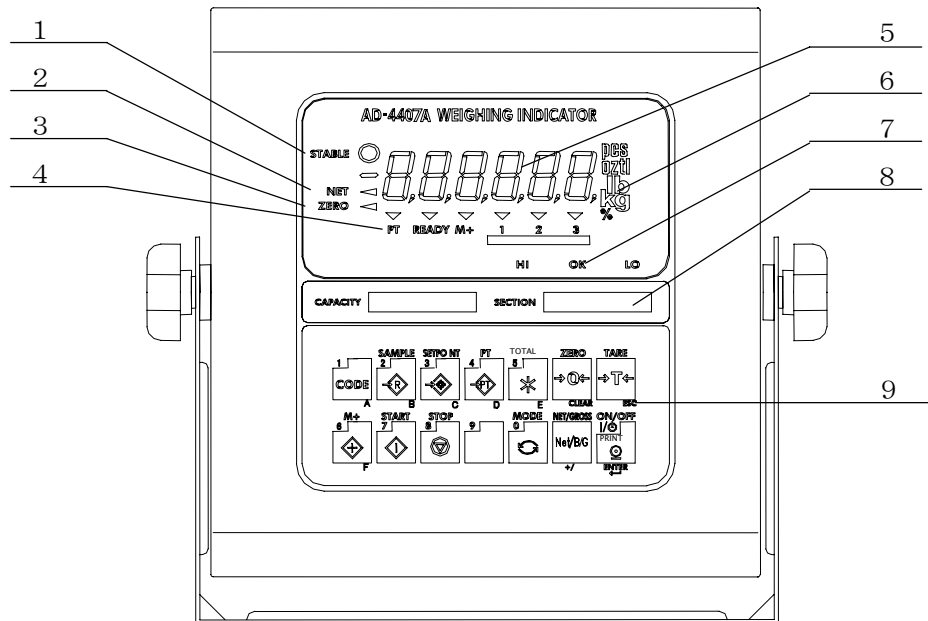

No.	Name	Description
1	STABLE	Indicates when the display is stable.
2	NET	Indicates when the weight is net weight.
3	ZERO	Indicates when the display weight is in the Zero range.
4	PT	Indicates when the PRESET TARE value is being used.
	READY	Indicates the state of comparison or batching.
	M+ (Accumulation)	Indicates when there is a result of addition or accumulation.
	Triangle▼1,2,3	Depending on the function selected, indicates various states.
5	Main display	Displays the weight data, stored parameters and accumulated result.
6	UNIT part	Unit used to weigh.
7	HI/OK/LO	Indicates the results of comparison.
8	Capacity label	To note the capacity and division. (provided as an accessory)
9	CODE key	The key to select the code memory.
	SAMPLE key	The key to store the unit weight for counting function.
	SETPOINT key	The key to store the comparator value.
	PT key	The key to store the PRESET TARE value.
	TOTAL key	The key to display the total weight.
	M+ key	The key to perform accumulation.
	START key	The key to start comparison / batch weighing.
	STOP key	The key to stop comparison / batch weighing.
	MODE key	The key to switch the unit used to weigh.
	0 – 9 key	The numerical keys.
	A – F key	The key to enter a value (press the NET/GROSS key at the same time).
	ZERO key	The key to zero the current display.
	CLEAR key	The key to clear the data.
TARE key	The key to perform tare.	

9	ESC key	The key to proceed to the next step without changing the data.
	NET/GROSS key	The key to select net or gross weight in the display.
	+/- key	The key to select the sign of a value.
	ENTER key	The key to confirm parameters and store the data.
	PRINT key	The key to output data.
	ON/OFF key	The key to turn the display on and off (OFF: hold for 3 seconds).



4.2. Rear Panel Description

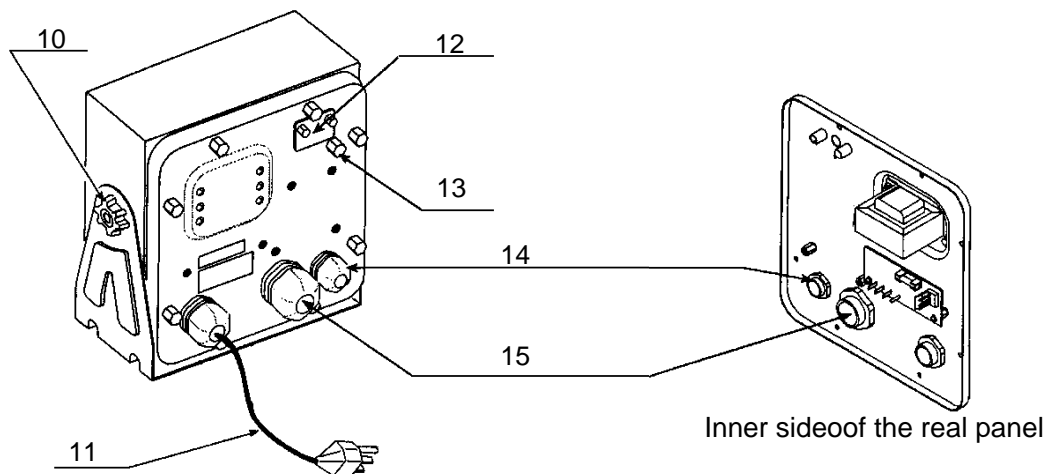

No.	Name	Description
10	Adjustment knob	Adjust the viewing angle.
11	Power cord	Connect to the AC power source.
12	CAL key (cover)	The CAL key is located inside the panel.
13	Grounding terminal	Connect to earth ground.
14	Load cell cable clamp	Connect the load cell cable.
15	Interface cable clamp	Connect the interface cable.

Caution Please confirm that the receptacle type and local voltage is correct for your indicator (scale).



4.3. Other Displays and Symbols

	Standby display.
	Zero error when turning the display on. If the [ESC] key is pressed, the current weighing value may be displayed.
Blank Decimal point	Overload display. Remove any load from the load cell immediately. It may cause damage to the load cell(s).
	Example of an error display.



4.4. Accessories and Options

Accessories	Instruction manual	1
	Time lag fuse	1
		FS-EAWK-200MA: 200mA (for 200-230 VAC) or FS-EAWK-315MA : 315mA (for 100-120 VAC)
	Annunciator label	1
	Capacity label	1
	Bracket	1

Caution Please confirm that the receptacle type and local voltage is correct for your indicator (scale).

Options

- OP-03 (AD-4407-03) RS-422/485 Interface, 3-Relay outputs
- OP-05 (AD-4407-05) RS-232C Interface, 3-Relay outputs and 3-Control inputs
- OP-07 (AD-4407-07) 4-20mA Analog output
- OP-08 (AD-4407-08) RS-232C Interface, 20mA current loop output, 3-Relay outputs and 1-Control input

One option can be installed at a time.



5. Calibration

This indicator, converts an input voltage from a load cell to the "mass" value, and displays it. Calibration is the adjustment function so that the scale (indicator) can display the weight correctly.



5.1. Items of Calibration Mode

There are four items in the calibration mode.

How to enter the calibration mode:

In the weighing mode, press the **CAL** key. After **CR L 10** is displayed for 2 seconds **CR L 0** will appear. Then the required items should be selected and displayed with the **MODE** key, then executed by pressing **ENTER** key.

Note: Calibration could be started by simultaneously pressing the **ZERO** and **TARE** key, instead of **CAL** key. The procedure is prohibited when the indicator has received a certified approval.

Items Required to be Performed

CR L SET

Sets capacity, resolution, decimal point position and display format, weighing range and unit. These items should be input first in order for the indicator to function as a weighing instrument. These parameters do not need to be changed again unless the indicator itself is replaced. For details, refer to "5.2.1. Configuring a Weighing Instrument".

CR L 0

Calibrates zero and span. This is required after installation, to get accurate data. For details, refer to "5.2.3. Zero Calibration" and "5.2.4. Span Calibration".

Optional Items to be Performed as Necessary

Lnr 0

Performs digital linearization. Refer to "5.4. Digital Linearization Function".

G SET

Compensates for acceleration of gravity. Refer to "5.5. Gravity Compensation Function".

Gravity compensation function: Compensates for weighing error between the calibration location and other weighing location using gravity acceleration.

In the calibration mode, the keys have functions as follows:

0 - 9

Numerical keys.

MODE

The key to display other items.

CLEAR

The key to restore the numerical value to the initial setting or to change the parameters.

+/-

The key to display other parameters.

ESC

The key to proceed to the next step without changing the parameters.

ENTER

The key to store new calibration data and proceeds to the next step.

CAL The key to store all data into memory and display **CRLOFF**. Press the **ON/OFF** key to turn the display off.

Note that the **ON/OFF** key does not function alone in the calibration mode. When a value is mistakenly set, press the **ESC** key while holding the **ON/OFF** key to finish the calibration mode without storing the value. After **CANCEL** is displayed, press the **ON/OFF** key to exit from the calibration mode and turns the display off.

Note: **CRLOFF** can be displayed by pressing the **+/-** key while pressing the **ON/OFF** key, instead of **CAL** key.

- Caution**
- **The maximum display is less than or equal to 40000 divisions. This number is calculated from the maximum capacity divided by the minimum division.**
 - **Check the accuracy of weighing instrument periodically.**
 - **Recommended mass, use a mass heavier than 2/3 maximum capacity.**
 - **Calibrate the scale, if it is moved to other location or the environment has changed.**
 - **It is not necessary to input the gravity acceleration correction, when calibrating the scale with a calibration mass at the place where the scale is used.**
 - **Enter the stable weight data while the STABLE mark is displayed. If unstable data is used, it may cause a weighing error. Arrange the condition using the F00 filter function.**
 - **The span calibration needs the zero calibration data. We recommend that you perform the span calibration immediately after the zero calibration.**
 - **If you use the dual range function of the multi-interval scale, perform the "Range Function", "Zero Calibration" and "Span Calibration".**



5.2. Calibration Procedure

5.2.1. Configuring a Weighing Instrument

This section explains how to specify capacity, resolution, decimal point position and display format, weighing range and unit. Perform this procedure when installing the indicator.

When **CALSEL** is displayed, enter this mode by pressing the **ENTER** key.

Specify the range and unit.

Single Range

Select resolution and decimal point position and format.



Specify the weighing capacity.

Dual Range

<First range> Select the resolution, decimal point position and format.



<First range> Select the weighing range



<Second range> Select the resolution



<Second Range> Specify the weighing capacity

For the range function, refer to “5.3. Weighing Range Function”.

Specifying the Range and Unit

Step 1 The range and unit of measure are displayed.

Range display : **SINGLE** : single range

DUAL : dual range

To change the range function, use the **CLEAR** key

Unit display: The active unit is displayed. The unit can be changed; such as kg or lb. Calibration is performed with the displayed unit.

Press the **MODE** key to select a unit.

Press the **+/-** key to select a unit for calibration. The unit for calibration (first unit) is displayed and the alternate unit (second unit) is blinking.

ENTER The key to store the parameter displayed and proceed to the next step.

ESC The key to proceed to the next step without changing the parameter.

Specifying the Resolution, Decimal Point Position and Format

Step 2 The resolution will be displayed as **d 0.1** with decimal point. The indicator displays triangle ▼ 1 and the first unit selected at the previous step. Specify the position of the decimal point with the **MODE** key. Specify the display format (point or comma) with the **+/-** key. Specify the resolution with the **CLEAR** key. The decimal point format, specified in this step, will only apply to the display. The decimal point format for serial data output is selected using the F-function settings. Press the **ENTER** key to store the parameters and proceed to the next step. When pressing the **ESC** key, regardless of what is displayed, the indicator will proceed to the next step without changing the parameters.

Specifying the Weighing Range of the First Range

Step 3 After displaying **[RPP]** for 2 seconds, single range or the weighing capacity will be displayed. When dual range is used, **[RPP1]** is displayed for 2 seconds. Triangle ▼ 1 will be displayed. Specify the range or the capacity using the **[0]** - **[9]** keys and press the **[ENTER]** key to store the parameter and proceed to the next step. When pressing the **[ESC]** key, regardless of what is displayed, the indicator will proceed to the next step without changing the parameter. The next step is Zero Calibration in single range or specifying the second range resolution in dual range.

Specifying the Second Range Resolution

Step 4 After displaying **[RnRES]** for 2 seconds, the resolution with decimal point and triangle ▼ 2 will be displayed. Specify the second range resolution in the same way as the first range. The decimal point cannot be moved. Specify the second range resolution greater than the first range.

Press the **[ENTER]** key to store the parameter and proceed to the next step.

When pressing the **[ESC]** key, regardless of what is displayed, the indicator will proceed to the next step without changing the parameter.

Specifying the Second Range Capacity

Step 5 After displaying **[RPP2]** for 2 seconds, the capacity with unit and decimal point is displayed. Specify the capacity in the same way as the first range capacity. The value should be greater than the first range capacity.

Press the **[ENTER]** key to store the parameter and proceed to Zero Calibration.

When pressing the **[ESC]** key, regardless of what is displayed, the indicator will proceed to the next step without changing the parameter.

5.2.2. To Get Stabilized Data

Step 6 Maintain the following conditions to calibrate the scale (indicator) correctly.

- ❑ Maintain a constant temperature, stable power and stable input voltage from the load cell.
- ❑ Avoid direct sunshine or the near the outlet of an air conditioner.
- ❑ Do not install the scale (indicator) where there is a strong magnetic field.

Step 7 Turn the display on and leave it for several minutes.

5.2.3. Zero Calibration

Procedure

Step 8 Start with the CAL 0 display.

Select a zero calibration method to adjust the zero point

Weighing input (Normal way)	The adjustment method with nothing on the weighing unit.	To step 9
Digital input	The numerical way to input a load cell output voltage.	To step 10

Weighing Input

Step 9 Place nothing on the weighing unit. Wait for the STABLE mark to turn on and press the ENTER key. The new zero point parameter will be stored. Proceed to step 11.

ESC key The key to proceed to the next step without changing the parameter.

Caution Do not press the ENTER key while the STABLE mark is off (detecting motion). Arrange the condition using the F00 filter function.

Digital Input

Step 10 Press the +/- key to display the input voltage parameter of the zero point in the unit of mV/V. Adjust the input voltage using the 0 - 9 keys.

ENTER The key to store the zero point parameter and proceed to the next step.

ESC key The key to proceed to the next step without changing the parameter.

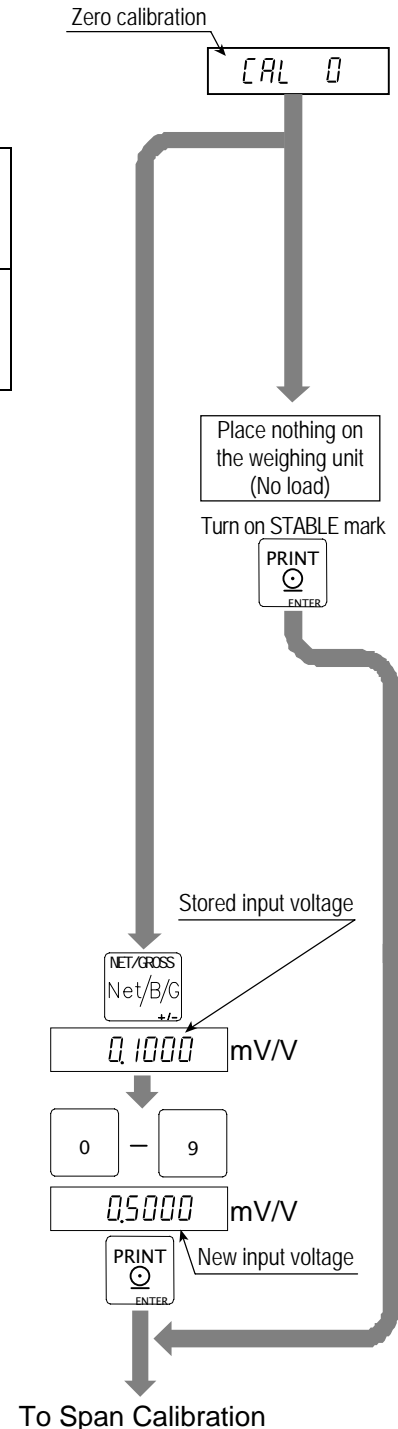

5.2.4. Span Calibration

Step 11 After displaying CAL F for 2 seconds, the capacity is displayed.

Select a span calibration method to adjust the capacity.

Weighing a mass less than the maximum capacity	The method to weigh a mass less than the maximum capacity.	To step 12
Weighing maximum capacity mass	The method to weigh a mass equivalent to the maximum capacity.	To step 14
Digital input	The numerical way to enter a load cell output voltage.	To step 16

Weighing a Mass except the Maximum Capacity

Step12 Specify a mass value using $\boxed{0}$ - $\boxed{9}$ keys.

Step13 Place a mass equivalent to displayed value on the weighing unit. Proceed to step 15.

Weighing Capacity Mass

Step14 Place a mass equivalent to the maximum capacity on the weighing unit.

Step15 Wait for the STABLE mark to turn on and press the $\boxed{\text{ENTER}}$ key. Proceed to step 17.
 $\boxed{\text{ESC}}$ key.....The key to proceed to step17 without changing the parameter.

Caution Do not press the $\boxed{\text{ENTER}}$ key while the STABLE mark is off (detecting motion). Arrange the condition using the F00 filter function.

Digital Input

Step16 Press the $\boxed{+/}$ key to display the input voltage parameter of the span in the unit of mV/V. Adjust the input voltage using the $\boxed{0}$ - $\boxed{9}$ keys. (It is possible to store a greater value than the capacity.)

$\boxed{\text{ENTER}}$ keyThe key to store the parameter and proceed to step 17.

$\boxed{\text{ESC}}$ key.....The key to proceed to step 17 without changing the parameter.

5.2.5. Exiting the Calibration Mode

Step17 $\boxed{\text{CALEnd}}$ is displayed.

Use the following keys.

$\boxed{\text{CAL}}$ key To store the parameters and display $\boxed{\text{CALoff}}$. Proceed to the next step.
 $\boxed{\text{CALoff}}$ can be displayed by pressing the $\boxed{+/}$ key while pressing the $\boxed{\text{ON/OFF}}$ key instead of $\boxed{\text{CAL}}$ key.

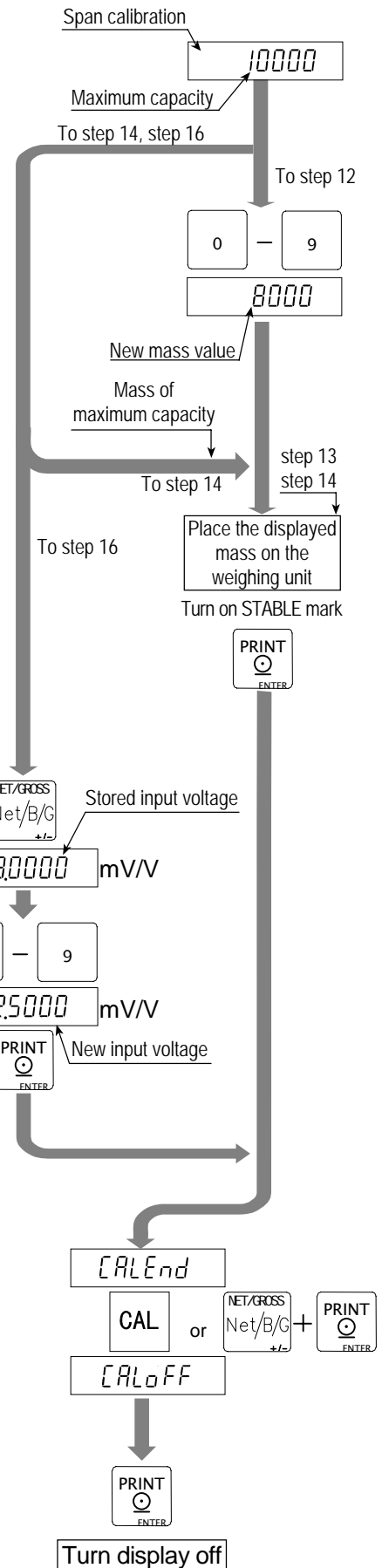

ESC key The key to store the parameters temporarily.

Proceed to the **ARL** display.

Press and hold the **ON/OFF** key and press the **ESC** key

No parameters are changed, **ARnEL** is displayed and the calibration mode is finished.

Step18 Press the **ON/OFF** key to turn the display off.



5.3. Weighing Range Function

In the weighing range function, select "single range" and "dual range". Specify each weighing interval (division) for the multi-interval instrument. Each weighing interval is displayed according to a net value or gross value.

Caution □ When single range is used, this function is not used.

Example 1 The gross display.

Specified parameters:

First range Range = 50.00 kg, division 0.02 kg

Second range Range = 100.00 kg (maximum capacity), division 0.1 kg

Display

0 kg to 50 kg : The first range, division 0.02 kg.

50 kg to 100 kg : The second range, division 0.1 kg.

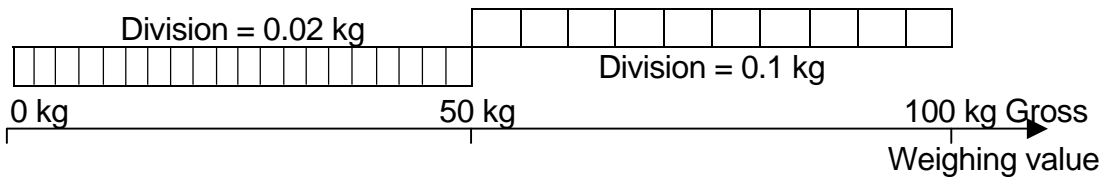

Example 2 The net display using a 40kg tare value.

Specified parameters: The same parameters as example 1.

Display

-40 kg to 50 kg : The first range, division 0.02 kg.

50 kg to 60 kg : The second range, division 0.1 kg.

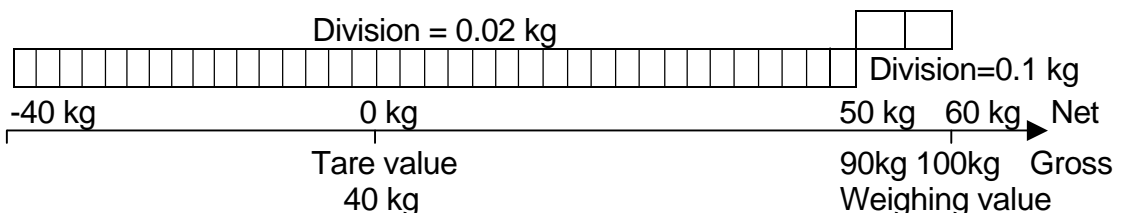

5.3.1. Selecting the Division and Range

Consider the following rules to design the weighing range.

Rule 1 Select the division and range of each weighing range so as to satisfy the following inequality.

The first range < the second range

The division of the next weighing range is automatically set larger than the division of the lower weighing range. Changing the division is possible.

Rule 2 When specifying the dual range, the upper limit value of the second range becomes the maximum capacity.

Rule 3 Select a resolution smaller than 40000. The resolution is a value obtained by dividing the maximum capacity by the minimum division of the first range.



5.4. Digital Linearization Function

Even if the zero and span calibration have been completed, there may still remain a linearity deviation caused by the performance of the weighing unit. The digital linearization function can rectify or reduce the linearity deviation using weighing points except zero and capacity. Up to three weighing points can be specified.

- Caution**
- **This function does not improve repeatability or hysteresis.**
 - **Use the mass on the condition that $L_{nr\ 1} < L_{nr\ 2} < L_{nr\ 3}$.**
 - **Do not press the **ENTER** key while the **STABLE** mark is off.**

Step 1 When **RL** is displayed, press the **MODE** key to display **Lnr**.

Step 2 Enter the zero point. Refer to "5.2.3. Zero Calibration".

Step 3 The value of the middle point is displayed after indicating **Lnr x**. x is 1, 2 or 3. The triangle ▼ mark of the same number(x) is displayed along with the value.

Step 4 Select a middle point.

- If you want to cancel the current procedure, press the **ESC** key to finish this function. Proceed to step 7 and other points are cleared (canceled).
- Select a middle point value using the **0** - **9** keys. Proceed to step 5.

Step 5 Place a mass equivalent to the displayed value on the weighing unit. Wait for the **STABLE** mark to turn on and press the **ENTER** key. Proceed to step 6.

Step 6 If you include a 2nd and 3rd middle point, repeat steps 3, 4, 5 for each point. If you finish this function, proceed to step 7.

Step 7 Perform step 11 of "5.2.4. Span Calibration" immediately.



5.5. Gravity Compensation Function

- If the scale is used at the calibration location, it is not necessary to perform this function.
- If there is a difference of gravity acceleration between the installed location and calibration location, it may cause a weighing error. This function specifies these gravity accelerations and corrects the span error.

- Note**
- **The decimal point is not displayed in the function. Example:** $\boxed{9798} = 9.798 \text{ m/s}^2$
 - **When span calibration is executed, the gravity acceleration correction will be cleared and the two gravity acceleration values will return to the factory settings.**

Step 1 At the $\boxed{CAL \ 0}$ display, press the \boxed{MODE} key until $\boxed{G \ SET}$ is displayed and press the \boxed{ENTER} key to enter the gravity compensation function.

If you want to cancel the current procedure, press and hold the $\boxed{ON/OFF}$ key and press the \boxed{ESC} key to display \boxed{CANCEL} . Then, no parameters are changed and the calibration mode is finished. Press the $\boxed{ON/OFF}$ key to turn the display off.

Step 2 The parameter is displayed with triangle ▼ 1. Enter the gravity acceleration of the calibration location using the $\boxed{0} - \boxed{9}$ keys. The parameter xxxx is the gravity acceleration.

\boxed{ENTER} key .. The key to store the new gravity acceleration and proceed to step 3.

\boxed{ESC} key..... The key to return to $\boxed{G \ SET}$ without changing the value.

Step 3 The parameter is displayed with triangle ▼ 2. Enter the gravity acceleration of the installed location using the $\boxed{0} - \boxed{9}$ keys. The parameter xxxx is the gravity acceleration.

\boxed{ENTER} key .. The key to store the new gravity acceleration and proceed to step 4.

\boxed{ESC} key..... The key to return to step 2 without changing the value.

Step 4 Now $\boxed{G \ xxxx}$ is displayed. Press the \boxed{CAL} key to store the parameters. The \boxed{CALOFF} is displayed. Proceed to step5.

Note: \boxed{CALOFF} can be displayed by pressing the $\boxed{+/-}$ key while pressing the $\boxed{ON/OFF}$ key, instead of \boxed{CAL} key.

Step 5 Press the $\boxed{ON/OFF}$ key to turn the display off.

5.5.1. Gravity Acceleration Table

Amsterdam	9.813 m/s ²	Manila	9.784 m/s ²
Athens	9.800 m/s ²	Melbourne	9.800 m/s ²
Auckland NZ	9.799 m/s ²	Mexico City	9.779 m/s ²
Bangkok	9.783 m/s ²	Milan	9.806 m/s ²
Birmingham	9.813 m/s ²	New York	9.802 m/s ²
Brussels	9.811 m/s ²	Oslo	9.819 m/s ²
Buenos Aires	9.797 m/s ²	Ottawa	9.806 m/s ²
Calcutta	9.788 m/s ²	Paris	9.809 m/s ²
Chicago	9.803 m/s ²	Rio de Janeiro	9.788 m/s ²
Copenhagen	9.815 m/s ²	Rome	9.803 m/s ²
Cyprus	9.797 m/s ²	San Francisco	9.800 m/s ²
Djakarta	9.781 m/s ²	Singapore	9.781 m/s ²
Frankfurt	9.810 m/s ²	Stockholm	9.818 m/s ²
Glasgow	9.816 m/s ²	Sydney	9.797 m/s ²
Havana	9.788 m/s ²	Tainan	9.788 m/s ²
Helsinki	9.819 m/s ²	Taipei	9.790 m/s ²
Kuwait	9.793 m/s ²	Tokyo	9.798 m/s ²
Lisbon	9.801 m/s ²	Vancouver, BC	9.809 m/s ²
London (Greenwich)	9.812 m/s ²	Washington DC	9.801 m/s ²
Los Angeles	9.796 m/s ²	Wellington NZ	9.803 m/s ²
Madrid	9.800 m/s ²	Zurich	9.807 m/s ²

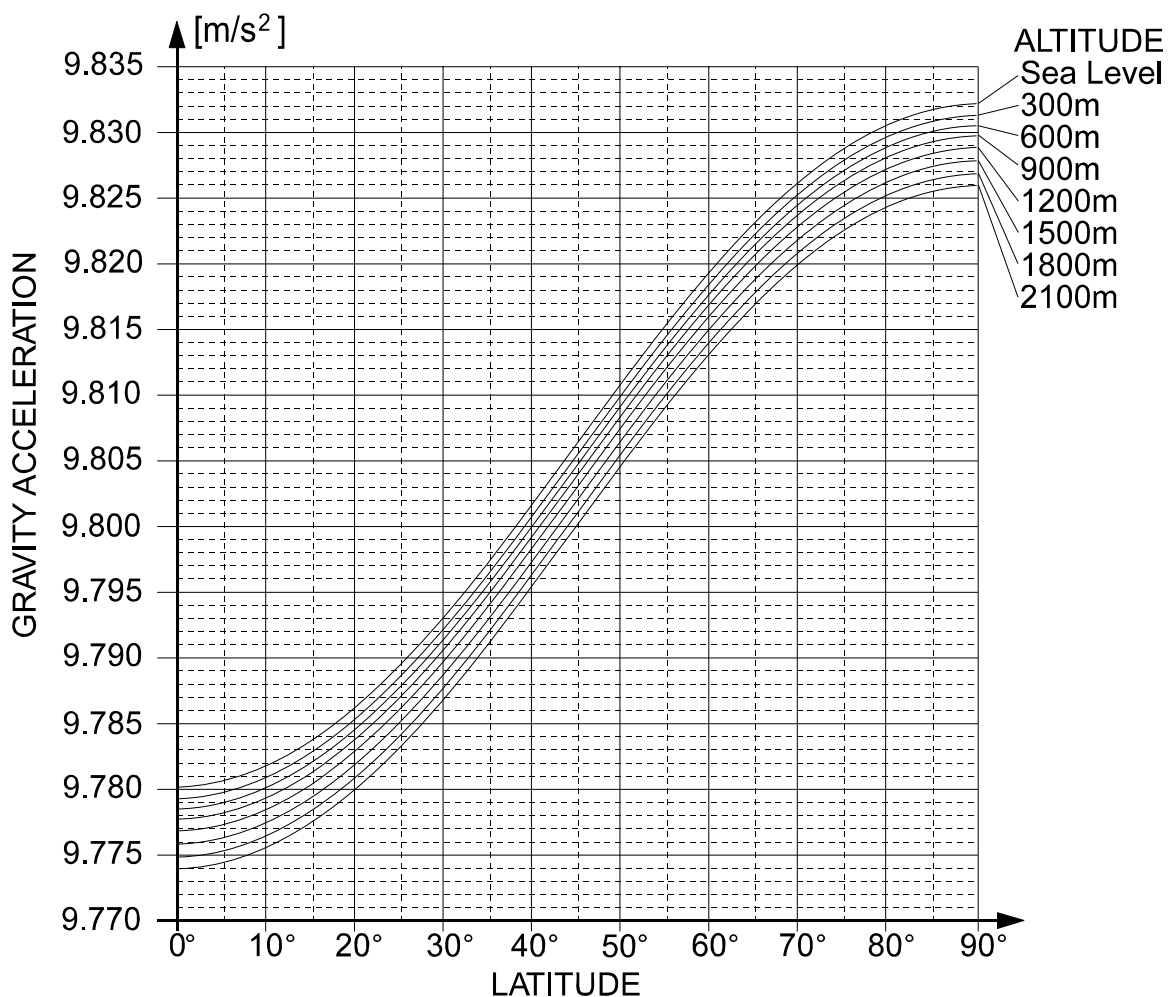



5.6. Calibration Error Code List

Exiting from a Calibration Error

ESC key..... The key to return to the point where an error occurred. Retry the operation.

ESC key while pressing the **ON/OFF** key.

No parameters are changed, **CANCEL** is displayed and the calibration mode is finished. Press **ON/OFF** key to turn the display off.

Error Code List

If an error has occurred during the calibration mode, the following code is displayed.

Error code	Description
<i>Err 0</i>	In multi-interval scale. The last division is set to maximum (d-50). Therefore the next division can not be entered.
<i>Err 1</i>	Resolution exceeds 40000. (Resolution = maximum capacity/ minimum division) Reduce the maximum capacity or increase the minimum division.
<i>Err 2</i> <i>Err 3</i>	The load cell output is too large or too small at zero calibration. Check the weighing unit and load cell. Refer to "3.4. Verifying Load Cell Output and Input Sensitivity".
<i>Err 4</i>	The calibration mass value exceeded the maximum capacity. Use the calibration mass less than the maximum capacity.
<i>Err 5</i>	The selected calibration mass is smaller than the minimum division.
<i>Err 6</i>	The new input sensitivity is less than 0.15 $\mu\text{V}/\text{division}$. Increase the input sensitivity. Refer to "3.4. Verifying Load Cell Output and Input Sensitivity".
<i>Err 7</i>	When a mass is placed on the weighing unit, the load cell output becomes a negative value. Check the load cell cable connections and the direction of load cell mounting.
<i>Err 8</i>	The load cell output exceeds the input range before reaching the maximum capacity. Adjust zero balance referring to "3.4. Verifying Load Cell Output and Input Sensitivity". Replace with a load cell designed for a smaller output. Or reduce the maximum capacity.
<i>Err 9</i>	The weight value is out of the input range at zero calibration or span calibration. Check the weighing unit and cables.
<i>Err 12</i>	The first weighing range is larger than second weighing range.
<i>Err 13</i>	An incorrect mass is selected at the digital linearization function. Select a mass of the following relation. $L_{nr 1} < L_{nr 2} < L_{nr 3}$.
<i>E Err</i>	An unacceptable value is selected in the gravity acceleration function.



6. Functions

There are two parameters lists, one for the F-functions and one for the CF-functions. These functions control the indicator. The parameters of each function are stored in the non-volatile memory, and are not lost even if power is turned off.

F-functions: These parameters can always be changed and are used for internal settings.

CF-functions: If you accept a certified approval of the weighing instruments, the CAL cover (rear panel) must be sealed. In this case, parameters of the CF-function can not be changed.



6.1. Changing the Function Settings

To enter the function setting mode, do either of the following.

1. When the display is off, press the **ON/OFF** key while pressing the **+/-** key.
2. When in the weighing mode, press both the **+/-** and **ON/OFF** keys at the same time.

In the function setting mode, **F00** will be displayed.

Selecting an Item

Step 1 Select an item using the **0** - **9** keys.

ENTER key The key to display a parameter of the selected item.
Proceed to step 2.

ESC key To finish the function setting mode and enter the weighing mode.

CAL key The key to switch between F-functions and CF-functions.

Selecting a Parameter

Step 2 Select a parameter using the **0** - **9** keys.

ENTER key The key to store the parameter and return to step 1.

ESC key The key to return to step 1 without changing the parameter.

CLEAR key The key to restore the display to the initial setting.(Type1)
Changes the sub item.(Type2, Type3) Type2 and Type3 are indicated in the parameter table.

Exiting from the Function Setting Mode

Press **ESC** key to proceed to the weighing mode when an item number is displayed.

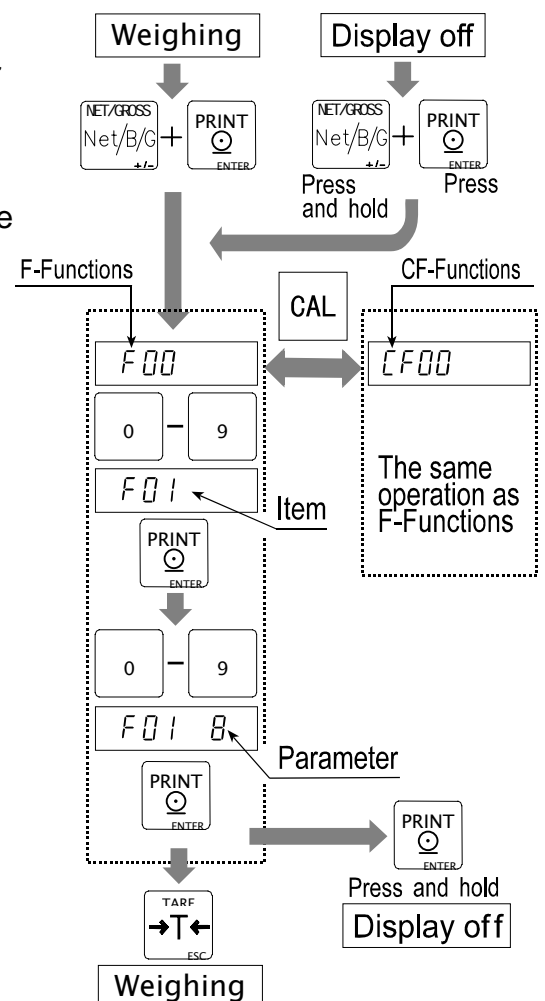



6.2. F-Functions

Weighing Conditions (Digital Filter, Zero Tracking and Stability)

Item	Parameter		Description
F00 Filter Motion / Averaging time	0	2 d/ 1.6s	If weak filter is set, the response will be fast, but will be more sensitive to external influences such as vibration.
	1	4 d/ 1.6s	
	2	8 d/ 1.6s	
	3	16 d/ 1.6s	
	4	32 d/ 1.6s	
	5	64 d/ 1.6s	
	6	128 d/ 1.6s	
	7	2 d/ 3.2s	
	*8	4 d/ 3.2s	
	9	8 d/ 3.2s	
	10	16 d/ 3.2s	
	11	32 d/ 3.2s	
	12	64 d/ 3.2s	
	13	128 d/ 3.2s	
F01 Zero tracking	0	OFF	This function traces the weight value drifting around the zero point slowly, displayed as zero. If a strong parameter is set, a very small zero drift may be not detected. If [F00] is 1, then only 0 or 1 can be selected for F01. (Initial setting is 1)
	1	0.5 d/ 1s	
	2	1.0 d/ 1s	
	3	1.5 d/ 1s	
	4	2.0 d/ 1s	
	5	2.5 d/ 1s	
	6	0.5 d/ 2s	
	7	1.0 d/ 2s	
	*8	1.5 d/ 2s	
	9	2.0 d/ 2s	
F02 STABLE mark Motion detection condition	0	No motion detection	The function to set the condition of judgment whether a weight value is unstable or stable. The ZERO key and TARE key are active in the stable state. If these keys need to be active in the unstable state, select 1 for [F04]. If [F00] is 1, then only 6 or 7 can be selected for F02. (Initial setting is 6.)
	1	0.5 d/ 0.5s	
	2	1.0 d/ 0.5s	
	3	2.0 d/ 0.5s	
	4	3.0 d/ 0.5s	
	5	4.0 d/ 0.5s	
	6	0.5 d/ 1s	
	7	1.0 d/ 1s	
	*8	2.0 d/ 1s	
	9	3.0 d/ 1s	
10	4.0 d/ 1s		
F03 Auto Printing/Auto Accumulation timing	0	Once (STABLE on)	Set the number of times the STABLE mark turns on in succession, before output/print out. If [F00] is 1, then only 2 or 3 can be selected for F03.
	1	Twice in succession	
	*2	Three times	
	3	Four times	

d: division (weighing interval) of first range.

s: second.

*: Initial settings.

Display and Other General Functions

Item	Parameter		Description
F04 Display update rate	* 0	5 times/s	The selection in the unstable condition.
	1	10 times/s	
F05 [Type2] Buzzer	1 x	Key click (ON/OFF)	Left: Item, select using the ZERO key Right: Parameter, select using the 0 - 9 keys 0: OFF 1: Continuous 2: 4 times/s 3: 2 times/s 4: 1 time/s 5: 1 time/2s Initial value is 11, others x0.
	2 x	LoLo / Zero band	
	3 x	Lo	
	4 x	OK	
	5 x	HI	
	6 x	HiHi / Batch finish / Full	
F06 Device ID (Address)	00 to 99	Command address or DeviceID	Initial setting is 00.
F07 Counting function	* 0	Disable	
	1	Enable	

*: Initial settings.

s: second.

Key Switch

Item	Parameter		Description				
F12 [Type2] Disabling key switches	2 0		<p>Left: Key Right: * 0 Enable 1 Disable</p> <p>ZERO key to select a key F : The same function as the CAL key</p> <p>0, 1 key to select Enable/Disable</p> <p>When F13, F14 and F15 are set to 17 and the terminal is connected to the common, all keys are enabled, regardless of the F12 setting.</p>				
		<table border="1"> <tr> <td>* 0</td> <td>Enable</td> </tr> <tr> <td>1</td> <td>Disable</td> </tr> </table>		* 0	Enable	1	Disable
	* 0	Enable					
	1	Disable					
		1 CODE key					
		2 SAMPLE key					
		3 SETPOINT key					
		4 PT key					
		5 TOTAL key					
		6 M+ key					
		7 START key					
		8 STOP key					
		9 "9" key					
		A MODE key					
		b ZERO key					
		c TARE key					
		d NET/GROSS key					
	e PRINT key						
	F ZERO+TARE = CAL						

*: Initial settings.

External Input

Item	Parameter	Description
F 13 EXT1 Function selection of external input	* 0	Not used (No function)
	1	ZERO key
	2	TARE key
	3	NET/GROSS key
	4	ON/OFF key
	5	PRINT key, ENTER key
	6	(No function)
	7	Serial data output (Format 1)
	8	Serial data output (Format 2)
	9	Accumulation (M+)
	10	Start batching
	11	Stop batching
	12	"Over" signal, Gross over and display data out when ON
	13	NET weight display when shorting the terminal.
	14	Accumulated data display when shorting the terminal.
	15	Execute comparison when shorting the terminal.
	16	Display by the second unit when shorting the terminal.
	17	All keys are enable when shorting the terminal. (Ignores the F 12 temporarily)
	18	Inhibit memory code reading when shorting the terminal.
	19	Start averaging to hold
20	Release holding data	
F 14 EXT2	0 to 17, 19 and 20	Same as F 13
	18	Memory cord (BCD 1)
F 15 EXT3	0 to 17, 19 and 20	Same as F 13
	18	Memory cord (BCD 2)

*: Initial settings.

Accumulation

Item	Parameter	Description
F 20 [Type2] Accumulation Mode	10 11	Do not add(0)/Add(1)
	20 21	Manual(0)/Automatic(1)
	30 31	+ Only(0) / Both +/- (1)
	40 41	OK only(0)/All data(1)
F 21 Inhibit region for accumulation	0	Add data anytime
	* 1	Above ± 5 d
	2	Above ± 10 d
	3	Above ± 20 d
	4	Above ± 50 d
		Left: Sub item, select using the ZERO key Right: Setting, select using the 0 , 1 keys Initial settings: 10, 21, 31, 41
		Selection of the inhibit region for accumulation. Do not set F 21 to 0 when Auto accumulation (F 20=21).

d: division (weighing interval) of first range.

*: Initial settings.

Comparator

Item	Parameter	Description	
F22 Comparator function	* 0	Not used	
	1	Upper/lower limit comparison (2 limits)	
	2	Upper/lower limit comparison (Target and allowance)	
	3	Upper/lower limit comparison (Target and % allowance)	
	4	HH/Hi/OK/Lo/LL comparison (4 limits)	
	5	HH/Hi/OK/Lo/LL comparison (Target and allowance)	
	6	HH/Hi/OK/Lo/LL comparison (Target and % allowance)	
	7	Check weighing 1	
	8	Check weighing 2	
	9	Check weighing 3	
	10	Simple batch 1	
	11	Simple batch 2	
	12	Simple batch 3 (Loss in weight)	
F23 (F22= 1 to 6) [Type2] Validation of comparison	10 11	Includes zero band(1)	Initial settings are 11,2 1,3 1 and 40.
	20 21	Includes minus(1)	
	30 31	Stable(0) /All time(1)	
	40 41	All time(0)/Start, stop(1)	
F23 (F22= 10 to 12) [Type2] Sub function for batch weighing	10 11	Tare when start(1)	Initial settings are 11,2 1,3 1 and 40.
	20 21	Stop after Full by key(0)/Auto(1)	
	30 31	Over/Under judgment: after dribble flow(0) / Batch finish(1)	
	40 41	No function	
F24 Relay output selection	* 0	Over	Effective when F22=7,9, 10 or 12. F22=9, 10, 12
	1	Under	
	2	Finish (F22= 10) / Full (F22=9, 12)	
F25 Batch finish output time	00 to 99	Relay on time by 0.1second step (00 : continuous to zero band)	Initial setting is 00.
F26 Zero band	-999999 to 999999		Initial setting is 0.

*: Initial settings.

Hold

Item	Parameter	Description	
F27 Hold mode	* 0	Not hold (Hold function is off)	
	1	Manual hold	
	2	Auto hold	
	3	Manual and Auto hold	
F28 Averaging time	00 to 99	Averaging time by 0.1second step (00 : hold at start)	Initial setting is 00.

*: Initial settings.

Data Output *: Initial settings.

Item	Parameter	Description	
F30 Data output	* 0	No data output	
	1	Analog output	Set F31, 32, 33
	2	Serial output	RS-232C,
	3	Serial output (Zero suppressing)	RS-422/485

Analog Output *: Initial settings.

Item	Parameter	Description	
F31 Output data	* 0	Display data	
	1	Gross data	
	2	Net data	
F32 Weight value at 4mA output	-999999 to 999999 (Initial setting is 0)		Polarity is changed by pressing the +/- key.
F33 Weight value at 20mA output	-999999 to 999999 (Initial setting is 10000)		

Serial Data Format

Item	Parameter	Description		
F34 [Type3] Serial data format 1 Initial value 19, 2E, 3A 4F E50	x 0	Terminator	Left 3 digits: order of output (1-999), select using the ZERO key	
	x 1	Device ID (selected at F06)		
	x 2	Code memory number		
	F35 [Type3] Serial data format 2 Initial value 17 2F E30	x 3	Data number *	Right 1 digit: output data, select using the 0 - 9, A - F keys
		x 4	Result of comparison	
		x 5	(Reserved)	
		x 6	(Reserved)	
		x 7	Accumulated data	
		x 8	Accumulation count	
	x 9	Stable / Over	"Exxx" indicates the end of data to output	
	x A	Displayed weight		
	x b	Gross weight		
	x c	Net weight		
	x d	Tare weight		
	x E	Weight type (G / N / T, refer to [F06])	NET/GROSS key: Expand or shorten output data length	
	x F	Weight unit (Refer to [F07])		

- Comma of the parameter display indicates that the comma (F46=0, semi-colon for F46=1) is output after the data. To turn this mark on and off, press the 9 key while pressing NET/GROSS key.
Output of initial setting of F34 (19, 2E, 3A 4F E50) is like "ST,GR,+12345.6kg".
- The data number (parameter 3) increments automatically with each serial data output from 1 to 99999 (1 comes after 99999). The starting number can be set by the keys.
Press the CODE(1) key while pressing the PRINT key in the weighing mode. The display changes to DATA r then r xxx. "xxx" is the next data number. Use the 0 - 9 keys to enter the number and press the ENTER key to store the number and return to the weighing mode.

Current Loop Output

Item	Parameter	Description
F36 Output data	* 0	Displayed data
	1	Gross data
	2	Net data
	3	Tare data
	4	Gross data / Net data / Tare data
F37 Output mode	0	Stream mode
	1	Manual mode
	2	Auto print mode(+)
	3	Auto print mode(+/-)
	4	When accumulation, automatically output
	* 5	Not used
F38 Delay for F36=4	* 0	No delay
	1	2.0 seconds (No delay when F37=0)
F39 Baud rate	0	600 bps
	1	1200 bps
	* 2	2400 bps

*:Initial settings.

bps: bit per second.

Serial Interface

Item	Parameter	Description
F40 Output mode	* 0	Stream mode, command is not acceptable
	1	Manual mode, command is effective
	2	Auto print mode(+), command is effective
	3	Auto print mode(+/-), command is effective
	4	When accumulation, automatically output
	5	Command mode (output by command only)
F41 Accumulated data output at accumulated data display	0	No output
	* 1	Manual, Fixed format
	2	Auto, Fixed format
	3	Manual, Format 1 (F34)
	4	Auto, Format 1 (F34)
	5	Manual, Format 2 (F35)
F42 Delay for continual data	* 0	No delay
	1	0.5 second
	2	1.0 second
	3	1.5 seconds
	4	2.0 seconds
F43 Command address	* 0	Not use
	1	Used (selected at F06)
F44 Time out	* 0	Approx. 1 second
	1	No limitation
F45 Terminator	* 0	CR, LF (0Dh, 0Ah)
	1	CR (0Dh)

*: settings.

Serial Interface (continued)

Item	Parameter	Description	
F46 DP / Delimiter	* 0	DP:point(.) / Delimiter:comma(,)	Common to sending/receiving
	1	DP:comma(,)/ Delimiter:semicolon(,;)	
F47 Baud rate	0	600 bps	
	1	1200 bps	
	* 2	2400 bps	
	3	4800 bps	
	4	9600 bps	
F48 Data bits, parity	* 0	Data 7bits, Even parity	
	1	Data 7bits, Odd parity	
	2	Data 8bits, Non parity	

*: Initial settings. bps: bit per second.

Description of "Stream Mode"

Function F37 0, F40 0

Operation The data is output at every sampling (when refreshing the display).
Use this mode to output data to an external display (The data may not be output due to timing of the baud rate and internal sampling rate) or to print data by pressing the **PRINT** key on the printer.

Description of "Manual Print"

Function F37 1, F40 1

Operation When the **PRINT** key is pressed, the stable weight data is output just once.

Description of "Auto Print Mode"

Function F37 2, F37 3, F40 2 or F40 3

Operation When the weight data enters the "inhibit region for output" and becomes stable in the "permission region of output", the stable data is output or printed just once. To use this mode, set F02 to 1 to 10, but not 0.

- For weighing (and removing) each object and printing the data.
- In case of F37 2, F40 2
"Inhibit region for output" $\leq +5d$. $+5d < \text{"permission region of output"}$.
- In case of F37 3, F40 3
 $-5d \leq \text{"inhibit region for output"} \leq +5d$.
"Permission region of output" $< -5d$, $+5d < \text{"permission region of output"}$.
d: division (weighing interval) of the first range.

Description of "Delay for continual data"

Function F38, F42

Operation This function can be used in the "Auto print mode" and "Manual print mode".
When using a non-buffered printer, set to F42 3 and F43 1 (or F38 1).



6.3. CF-Functions

Item	Parameter	Description
[F00] Zero track width, motion detection condition	* 0	No limitation
	1	Use limitation at F01, F02, F03, F27 and F28.
[F01] Zero range (by pressing the ZERO key)	* 0	±2% of CAP, Tare limit is 100 % CAP
	1	±10% of CAP, Tare limit is 100 % CAP
	2	±3% of CAP, Tare limit is 50 % CAP
	3	±4% of CAP, Tare limit is 50 % CAP
[F02] Power on zero range	0	Not to zero when turning the display on.
	* 1	±10% of CAP
	2	± 3% of CAP
[F03] Zero tracking	0	Gross when displaying gross.
	1	Gross
	* 2	Gross or Net when displaying net.
[F04] TARE, ZERO in motion / TARE at negative gross value	TARE, ZERO in motion / TARE at negative gross	
	* 0	Not accepted / Not accepted
	1	Execute / Not accepted
	2	Not accepted / Execute
[F05] Output overload and unstable data	* 0	Not to output unstable or overload data. Effective in key mode.
	1	To output data always.
[F06] Header 2	GROSS / NET / TARE / Preset TARE	
	* 0	GR / NT / TR / TR
	1	GR / NT / TR / PT
[F07] Figure number of unit	* 0	Two digits
	1	Three digits
[F08] Accumulation function	* 0	Not used (Ineffective)
	1	Used (Effective)
[F09] Preset Tare (PT)	* 0	Used (Effective)
	1	Not used (Ineffective)

CAP : maximum capacity

*: Initial settings

Power on ZERO (CF02)

[F02]=0 After power on, the weight display starts immediately.

[F02]=1,2,3 When the zero range is exceeded at power on, ----- is displayed.
Press the **ESC** key to start the weight display



7. Tare

- The function is used to display a net value with the container weight subtracted from the total weight, if you place an object into a container to weigh it.
- Using a serial interface such as RS-232C, you can do this from the external equipment.

Caution □ When turning the display off with [F02]=1, 2 or 3, the tare data is cleared.
□ When turning the power off, the tare data is cleared.



7.1. Weighing Tare

Operation Place the tare on the weighing unit. Wait for the STABLE mark to turn on and press the **TARE** key to store the tare weight. The display changes to net.

Caution □ When the gross value is zero or negative, tare can not be used (with [F04]=0, 1).
To enable tare at zero or a negative gross value, specify at [F04].



7.2. Digital Input

Caution □ The input value is rounded off to the unit of division (weighing interval).
□ In the case of [F02]=1, 2 or 3(power-on zero), the displayed value will be zeroed when turning the display on.
□ When using a multi-interval scale, the usable input range is the first range.
□ In the case of [F09]=1(To inhibit preset tare), preset tare can not be used.
□ Preset tare is stored as one of the code memory data. Refer “9. Code Memory”.
□ Preset tare value can be set via the serial interface.

Step 1 Press the **PT** key to display the stored tare value and the triangle ▼ mark blinking. When the tare is cleared or is not used, the value is zero.

Step 2 Enter a new tare value using the 0 - 9 keys.

ENTER key The key to store a new tare value.

The triangle ▼ mark is turned on and the net is displayed.

ESC key The key to return to the previous stage (weighing mode or code memory number selection mode) without changing the stored value.



7.3. Clearing Tare

- When pressing the **TARE** key while gross is zero, tare is cleared and gross is displayed.
- When zeroing with the **ZERO** key, tare is cleared.



8. Accumulation

The function accumulates weight data and stores the total data and the accumulation count. Data is stored in non-volatile memory, and is not lost even if the power is turned off.



8.1. Preparation and Specification

Set the following parameters to use the accumulation function.

- Set CF-function $[F08]$ to 1 to enable the accumulation function.
- Specify the method of accumulation and data at $F20$ of the F-functions.
- Specify the inhibit region for accumulation at $F21$ of the F-functions.

Selection of Accumulation Mode, F20 of the F-functions

- There are two methods of accumulation; manual accumulation using the $[M+]$ key and automatic accumulation.
- The data to accumulate can be selected from "positive data only" or "both polarity data".
- The data to accumulate can be selected from "result of comparison is OK only" or "all results".

Accumulation Condition, F21 of the F-function

- In the case of manual accumulation mode, press the $[M+]$ key to accumulate weight data when the STABLE mark is displayed.
- Data can be accumulated after the weight data enters the "inhibit region for output". When turning the display on, the accumulation mode takes the same action.

Inhibit region for accumulation	F21	Description
Add data anytime	$F21\ 0$	Stable data can be used anytime
Above ± 5 d	$F21\ 1$	Factory setting
Above ± 10 d	$F21\ 2$	
Above ± 20 d	$F21\ 3$	
Above ± 50 d	$F21\ 4$	

- Caution**
- Do not set to $F21=0$ for the automatic accumulation mode.
 - If $F21$ is set to 0, the same data may be added two times or more.

Limitation of Accumulation Count and Total

- The limitation of accumulation count is 999999.
The limitation of total is 999999 ignoring the decimal point.
- If exceeding these limitations, the data is not accumulated.
Example: When the decimal point is set to "0.0", the limitation is "99999.9".



8.2. Display and Operation

Action of Accumulation

- When accumulating data, the display blinks once.

If the accumulated data is stored, the M+ mark is displayed.

Caution □ **This function can not accumulate data with a different unit. Specify a unit before use.**

Display of Accumulated Data

- With $[F08]=1$ (Effective accumulation function), press the **TOTAL** key. After **total** appears, the total data is displayed with the M+ mark blinking. Pressing the **TOTAL** key alternatively displays the accumulated data and the accumulation count. Press the **ESC** key to return to the weighing mode.
- The total data can be output. Refer to "Output of Accumulated Data" on the next page.

Undoing the Accumulated Data

- The last weight data can be deleted from the accumulated data unless new data has been accumulated.

Step 1 Press the **TOTAL** key to display **total** and the accumulated data.

Step 2 Press and hold the **+/-** key for more than 3 seconds. The display blinks once and the data, accumulated before the last weight data, is displayed.

Caution □ **External input can not be used.**

Clearing the Accumulated Data

Step 1 Press **TOTAL** key to display **total** and the accumulated data.

Step 2 Press and hold the **ZERO** key for more than 3 seconds. The display blinks once and the accumulated data is cleared.

Caution □ **External input can not be used.**

Initializing the Data Number and Clearing the Accumulated Data at the same time

- When the data number is included with the data of the serial data output, initializing the data number and clearing accumulated data can be done at the same time.

Step 1 Press **TOTAL** key to display **total** and the accumulated data.

Step 2 Press and hold the **ZERO** and **+/-** keys at the same time for more than 3 seconds. The display blinks once and the accumulated data is cleared. And the data number is initialized (1).

Caution □ **External input can not be used.**

Output of Accumulated Data

- The accumulated data can be output to the serial interface.
- Output by manual or automatic, and output data format is selected at *F41* of the F-function setting.

F41	Parameter	Manual/Automatic	Format
Accumulated data output at accumulated data display	0	No output	
	* 1	Manual (Initial setting)	Fixed format
	2	Automatic	
	3	Manual	Format 1(selected at <i>F34</i>)
	4	Automatic	
	5	Manual	Format 2(selected at <i>F35</i>)
	6	Automatic	

Step 1 Press the **TOTAL** key to display **total** and the accumulated data.

Step 2 If automatic output is selected, the data is output once.

Step 3 If manual output, press the **PRINT** key while the accumulated data is displayed, to output data.

Fixed data format : Count

□	□	□	□	N	,	+	0	0	0	0	0	0	0	1	CR	LF
---	---	---	---	---	---	---	---	---	---	---	---	---	---	---	----	----

□ Space(20h)

Header Data Terminator

Total

T	O	T	A	L	,	+	0	0	0	0	0	0	1	k	g	CR	LF
---	---	---	---	---	---	---	---	---	---	---	---	---	---	---	---	----	----

Header Data Unit Terminator



9. Code Memory

- This indicator has four code memories (1 through 4). Each code memory stores a set of setpoints, preset tare and the unit weight for piece counting.
- The data is stored in non-volatile memory, and is not lost even if power is turned off.
- Memory number 0 is a temporary memory and the data is lost when power is turned off.
- The active code memory number can be changed by key switch, external control input, or a command via the serial interface.
- The data set can be copied from one code memory to another code memory.



9.1. Using Code Memory

- Step 1 Press the **CODE** key in the weighing mode. $[[d x]$ is displayed with the current code memory number “x” blinking. Use the following keys:
- $[0 - 4]$ key The key to input the code memory number.
 - CLEAR** key..... The key to reset the code memory number (0).
 - $[+/]$ key..... The key to copy the data set to other code memory number. Proceed to step 3.
 - ESC** key The key to return to the weighing display without changing the code memory number.
 - ENTER** key The key to set the code memory number. Proceed to step 2.
- Step 2 The code memory number is set and the blinking stops. Use the following keys:
- SETPOINT** key The key to set the comparator value. Refer "10. Comparison".
 - PT** key The key to set the preset tare data. Refer "7.2. Digital Input".
 - ESC** key The key to return to step 1.
 - ENTER** key The key to store the selected code memory number's data and return to the weighing mode.
- Step 3 $[[OPY]$ is displayed for 2 seconds and then $[[x-y]$ is displayed with “y” blinking. Here, “x” is the code memory number specified at step 1 and “y” is the destination code memory number. Use the following keys:
- $[0 - 4]$ key The key to input the destination code memory number.
 - ESC** key The key to return to step 1.
 - ENTER** key The key to copy number x's data to the destination “y” and to return to step 1.

Changing the Code Memory Number by External Input

- The code memory number can be changed by external input from OP-05 or OP-08.
- Set F14 and F15 to 18. (OP-08 has only one input; set F15)
- F13=18 : Inhibit reading EXT.2 and EXT.3 to prevent unintentional reading when switching the codes.

EXT.2 (F 14)	EXT.3 (F 15)	Code Memory number
ON	ON	1
OFF	ON	2
ON	OFF	3
OFF	OFF	4



10. Comparison

- This function has the "upper / lower comparison", the "5-stage(HiHi / Hi / OK / Lo / LoLo) comparison", the "setpoint comparison" and the "simple batch". They compare the weight data with preset parameters and can output the result of the comparison to the display and buzzer, also to the relay-outputs of OP-03, OP-05 and OP-08.
- Set the F-function $F22$ and $F23$ to use the "upper / lower comparison", the "5-stage(HiHi / Hi / OK / Lo / LoLo) comparison" (these two comparison methods will be combined and hereafter be called the "Weight check mode"), and $F22$ through $F26$ to use the "setpoint comparison" and the "simple batch".
- There are four code memories for the setpoints. Data is stored in non-volatile memory and is not lost even if power is turned off.
- Code memory can be selected by key switch, external control input, or a command via the serial interface. Refer to "13.3. Command Format".



10.1. Weight Check Mode

- This function compares the weight data with the upper and lower limit values (upper/lower limit comparison) or with four limit values of HiHi, Hi, Lo and LoLo (5-stage comparison), and displays, sounds the buzzer and outputs the results to the three relays of HI, OK and LO. Use this comparison when judging whether a weight is proper.
 - Set the F-function $F22$ to 1, 2 or 3 to use upper/ lower limit comparison and $F22$ to 4, 5 or 6 to use 5-stage comparison.
 - Select a parameter of the F-function $F23$ for the comparison condition.
 - Set the F-function $F26$ (zero band) if $F23$ is set to 10 (not to compare in the zero band).
 - Specify the upper and lower limit / HiHi, Hi, Lo, LoLo limit values.
 - When entering the limit value(s), it is not necessary to enter the F-function $F22$ and $F23$ again unless comparison conditions are changed.
 - There are 3 type of limit values for each comparison.
 - (1) Set the limit value (upper and lower limit / HiHi, Hi, Lo, LoLo limit).
 - (2) Set the Target value and an acceptable tolerance(upper and lower) in weight.
The limit value is calculated automatically.
 - (3) Set the Target value and an acceptable tolerance(upper and lower) in percentage of the target weight. The limit value is calculated automatically.
- Example. Target = 50 kg, Upper limit = 51 kg, Lower limit = 48 kg
- (1) Hi (Upper limit) : 51 (kg), Lo (Lower limit) : 48 (kg)
 - (2) TG (Target) : 50 (kg), Hi (Upper acceptable tolerance) : 1 (kg),
Lo (Lower acceptable tolerance) : 2 (kg) not negative value
 - (3) TG (Target) : 50 (kg), Hi (Upper acceptable tolerance) : 2 (% of Target),
Lo (Lower acceptable tolerance) : 4 (% of Target) not negative value

10.1.1. Condition Formula for Comparison

Comparison is performed based on the following formula.

Upper/lower comparison

Judge	Condition Formula	Display	Output
HI	Upper limit (Hi limit) value < Displayed value	HI	HI
OK	Lower limit value \leq Displayed value \leq Upper limit value	OK	OK
LO	Displayed value < Lower limit (Lo limit) value	LO	LO

5-stage comparison

Judge	Condition Formula	Display	Output
HiHi	HiHi limit value < Displayed value	HI,▼2	HI
HI	Upper limit (Hi limit) value < Displayed value	HI	HI, OK
OK	Lower limit value \leq Displayed value \leq Upper limit value	OK	OK
LO	Displayed value < Lower limit (Lo limit) value	LO	LO, OK
LoLo	Displayed value < LoLo limit value	LO,▼3	LO

- ❑ The decimal point is ignored. Example: If the upper limit value is 10.0, enter 100.
- ❑ These parameters are stored in non-volatile memory, and are not lost even if the power is turned off. (except code 0 memory).
- ❑ When the displayed value becomes an overload (positive over), HI (over) is output. When the displayed value becomes an under load (negative over), LO (under) is output.
- ❑ This function compares the Hi / HiHi limit value first.
- ❑ This function does not check the relationship between the upper and lower limit values.

10.1.2. Setting the Upper/Lower Limit Values

Step 1 By pressing the **SETPOINT** key, the selected code memory number is displayed and the first comparison class term (Hi, TG, etc.) is blinking.

Step 2 Select the comparison class using the following keys:

SETPOINT key The key to select a comparison class.

ESC key The key to return to the previous stage (weighing mode or code memory number selection mode).

ENTER key The key to proceed to step 3.

Step 3 Set the setpoint values using the following keys.

0 - 9 key The key to enter a value.

ESC key The key to return to step 2 without changing the set value.

ENTER key The key to store the value and return to step 2.

Setting Order and Display for Weight Check Mode

F22	MODE	Display	1	2	3	4	5
1	Upper Lower 1	Setpoint	Upper	Lower			
		Class	Hi	Lo			
		Comparator	HI	LO			
2	Upper Lower 2	Setpoint	Target	Upper	Lower		
		Class	tG	Hi	Lo		
		Comparator	OK	HI	LO		
3	Upper Lower 3	Setpoint	Target	Upper	Lower		
		Class	tG	Hi	Lo		
		Comparator	OK	HI	LO		
		Unit		%	%		
4	5-stage 1	Setpoint	HiHi	Hi	Lo	LoLo	
		Class	HH	Hi	Lo	LL	
		Comparator	HI	HI	LO	LO	
		Triangle ▼	2			3	
5	5-stage 2	Setpoint	Target	HiHi	Hi	Lo	LoLo
		Class	TG	HH	Hi	Lo	LL
		Comparator	OK	HI	HI	LO	LO
		Triangle ▼		2			3
6	5-stage 3	Setpoint	Target	HiHi	Hi	Lo	LoLo
		Class	TG	HH	Hi	Lo	LL
		Comparator	OK	HI	HI	LO	LO
		Unit		%	%	%	%
		Triangle ▼		2			3



10.2. Setpoint Comparison

- This function includes the weighing sequence and is used for acquiring a preset target weight.
- Four parameters of "Final", "Preliminary", "Free fall" and "Zero band" are used for the setpoint comparison.
- The result of the sequence is output to the three relays of OP-03, OP-05 or OP-08.
- It is not necessary to enter the F-function $F22$ again unless comparison conditions are changed.

10.2.1. Description of Input Parameters and Outputs

$F22 = 7$ (Check weighing 1)

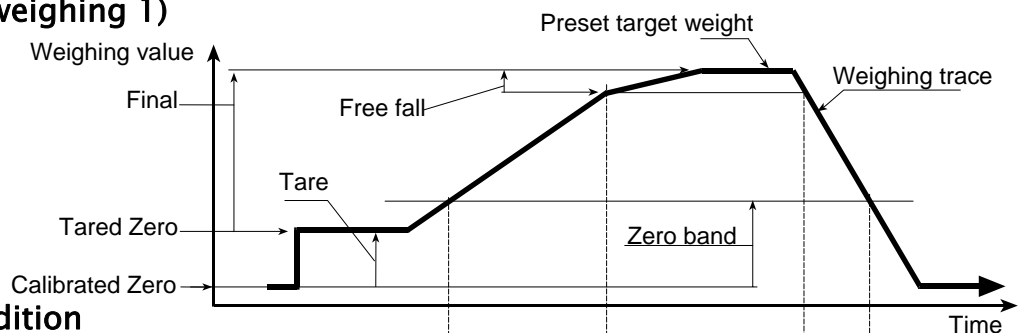

Output and Condition

Relay HI, ▼1, $Net \geq (Final - Free\ fall)$	OFF	ON	OFF
Relay LO, ▼3, $Gross < Zero\ band$	ON	OFF	ON

Relay OK output can be changed to OVER or UNDER by $F24$. The triangle ▼2 is not displayed.

OVER/UNDER is judged always and the result is output to the LED and the relay.

$F22 = 8$ (Check weighing 2)

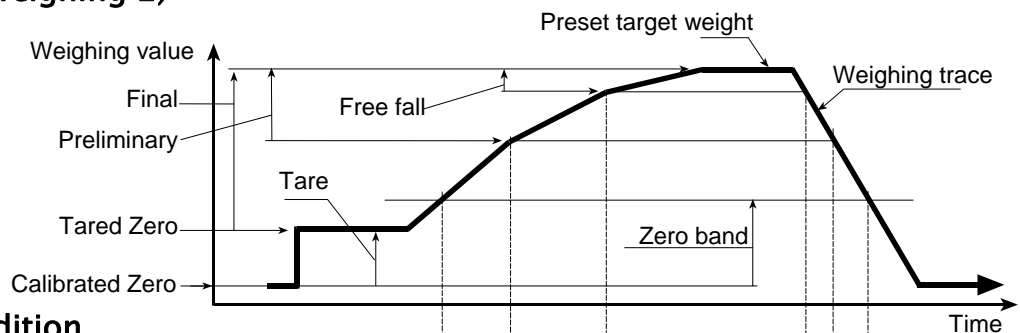

Output and Condition

Relay HI, ▼1, $Net \geq (Final - Free\ fall)$	OFF	ON	OFF
Relay OK, ▼2, $Net \geq (Final - Preliminary)$	OFF	ON	OFF
Relay LO, ▼3, $Gross < Zero\ band$	ON	OFF	ON

OVER/UNDER is judged always and the result is output to the LED but not to the relay.

F22 = 9 (Check weighing 3: Loss in weight)

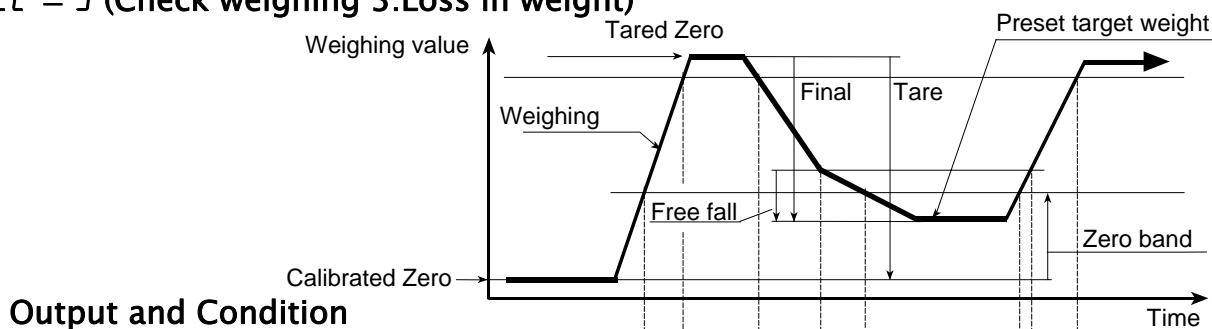

Output and Condition

Relay HI, ▼1, Net \geq (Final - Free fall)	OFF		ON		OFF
Relay LO, ▼3, Gross < Zero band	ON	OFF		ON	OFF
Relay OK*, ▼2, Gross \geq Full	OFF	ON	OFF		ON

* Relay OK output can be changed to OVER or UNDER by F24.

Triangle ▼ 2 is displayed when Gross \geq Full regardless of the F24 setting.

OVER/UNDER is judged always and the result is output to the LED and the relay.

10.2.2. Simple Batch

The weighing sequences of Simple batch (F22=10, 11 or 12) are similar to those of Check weighing (F22=7, 8 or 9) respectively. The differences are listed below.

- 1 Basically ON/OFF of the relay and the LED is reversed.
- 2 No judgement other than Zero band and Full before input Start signal.
- 3 The weighing completion condition is set by F23=2x and it is effective after Start.
- 4 The outputs of Preliminary and Free fall are off from weighing completion to the next start.
- 5 Weighing completion can be output by F24 and F25.
- 6 The start signal can be accepted after weighing completion even the weight is not within the zero band.
- 7 Over/Under output is set by F23=3x.

Start

Tare automatically when the Start is input if F23=11.

The READY mark turns off when the Start is input.

Weighing Completion

The weighing completion condition is set by F23=2x

F23=20 : Either the STOP key is pressed or the Batch stop input is on

F23=21 : Stable is detected after reaching Final

Before reaching Final, the STOP key or Batch stop input forces weighing completion even if F23=21.

Toward the Zero band

Preliminary and Free fall output maintain the off state.

Over/Under comparison starts. If $F23=30$, judgment starts when Free fall turns on.

The judgment is not latched and the output is according to the state at the time.

The Weighing completion relay is turned on if $F24=2$. The on time is set by $F25$.

The READY mark is blinking regardless of $F24$ and $F25$.

Start may be accepted at this state.

Returns to Zero band

Over/Under and Weighing completion output is off.

The READY mark is turned on.

10.2.3. Setting the Parameters of Setpoint Comparison

Refer to "10.1.2. Setting Upper/Lower Limit Values".

Zero band value is set at $F26$ of the F-Function, and the value does not belong to a specific code memory, but is used commonly.

Setting Order and Display for Setpoint Comparison and Simple batch

$F22$	MODE	Display	1	2	3	4	5
7	Setpoint Comparison 1	Setpoint	Final	Free fall	Over	Under	
		Class	Fi	FF	Hi	Lo	
		Comparator	OK		HI	LO	
		Triangle ▼		1			
8	Setpoint Comparison 2	Setpoint	Final	Free fall	Preliminary	Over	Under
		Class	Fi	FF	Pr	Hi	Lo
		Comparator	OK			HI	LO
		Triangle ▼		1	2		
9	Setpoint Comparison 3	Setpoint	Final	Free fall	Full	Over	Under
		Class	Fi	FF	Fu	Hi	Lo
		Comparator	OK			HI	LO
		Triangle ▼		1	2		
10	Simple Batch 1	Setpoint	Final	Free fall	Over	Under	
		Class	Fi	FF	Hi	Lo	
		Comparator	OK		HI	LO	
		Triangle ▼		1			
11	Simple Batch 2	Setpoint	Final	Free fall	Preliminary	Over	Under
		Class	Fi	FF	Pr	Hi	Lo
		Comparator	OK			HI	LO
		Triangle ▼		1	2		
12	Simple Batch 3	Setpoint	Final	Free fall	Full	Over	Under
		Class	Fi	FF	Fu	Hi	Lo
		Comparator	OK			HI	LO
		Triangle ▼		1	2		



11. Hold Function

- This function displays the hold weight data after averaging the weight data for a specific period.
- Useful to determine a living animal's weight.
- Averaging time can be set up to 9.9 seconds by a 0.1 second step.
- 3 methods are available to start averaging; manual start, start automatically after stable and manual / automatic start.
- Manual start is available with key switch or external input.
- Serial interface commands are also available; averaging start, releasing the hold data and outputting the hold state. Refer to "13.3.4. Commands for Hold Function".

- Caution**
- **This function can not be used with $[F00]=1$.**
 - **Averaging can not start at a displayed value smaller than +/- 5 digits.**
 - **OVER data is not included for averaging.**
 - **When powered off, hold is released automatically.**
 - **No peak hold function.**

The Display and the Data Output of Hold and Average

- The weight display blinks during the averaging period.
- The output data in the averaging period is the actual weight at the time.
- The weighing unit blinks when the weight display is in the hold state.
- The output data format of the hold weight data is the same as that of the normal weight data except the header of stable state is "HD" in the response to the "RW" or "RW,n"(n=1 or 2) command.

Relations to the Other Functions

- If automatic accumulation ($F20=2, 1$) and/or auto print ($F37=2, 3$, $F40=2, 3$) is set, accumulation and/or data output is performed after the hold data is obtained.



11.1. Setting the Hold Functions

- $F27$ determines how to start averaging.
 - $F27=1$ Manual start: Start averaging and release with key switch operation.
 - $F27=2$ Automatic start: After passing the inhibit region * and detecting stable **, start averaging automatically, release when the weight returns to the inhibit region.
 - $F27=3$ Both Manual start and Automatic start.
- *inhibit region 0 +/- 5 digits
 **stable detection Satisfied both $F02$ and $F03$

- $F28$ determines the averaging time by 0.1second step. $F28=0$ holds the data at averaging start.
- The key switch function as the HOLD key (Average start or release holding data): Press the **TOTAL** key while pressing the **ENTER** key.
- The external input function of averaging start is $I9$ and hold release is $P0$ of $F13$, $F14$ and $F15$. The function is accepted at the off to on edge of the external input.

Conditions of Averaging and Release

The method to start/stop averaging and release the hold state depends on the $F27$.

Condition	$F27=1$	$F27=2$	$F27=3$
Average start in the inhibit region	No	No	No
Average start with key switch (including unstable)	Yes	No	Yes
Average start with ext. input (including unstable)	Yes	No	Yes
Average start with command (including unstable)	Yes	Yes	Yes
Average start after passing the inhibit region and stable	No	Yes	Yes
Weight is entering the inhibit region at averaging	Continue	Stop	Stop
Weight becomes over at averaging	Pending	Stop	Pending
Hold key input at averaging	Stop	Stop	Stop
Release input from external input at averaging	Stop	Stop	Stop
Release command input at averaging	Stop	Stop	Stop
Hold key input at hold	Release	Release	Release
Release input from external input at hold	Release	Release	Release
Release command input at hold	Release	Release	Release
Weight is entering the inhibit region at hold	Continue	Release	Release
Weight becomes over at hold	Continue*	Continue*	Continue*

Pending: Suspend the count up timer and do not average under the condition.

Release: Key, ext. input and command are effective at over display.

Continue*: Continue hold, but over display.

Key Input and Command in the Hold State

Release hold and perform key function:

Keys: TARE, ZERO, SETPOINT, TOTAL

Commands: MT, MZ, HC

Continue hold and perform key functions

Keys: NET/GROSS, Accumulation, Comparison start/stop

Commands: other commands



12. Counting Function

This function determines the number of objects in a sample based on the unit weight. The unit weight is stored as one of the code memory data in non-volatile memory, and is not lost even if power is turned off.



12.1. Using the Counting Function

- Set $F07$ to 1 in the F-Functions.
- Select the code memory number. Refer to “9.1. Using Code memory”.
- Register the unit weight. Refer to “12.2. Unit Weight Registration”.
- Press the **MODE** key to enter the counting mode. The unit in the display changes to pcs.
- In the counting mode, TARE, ZERO, NET/GROSS and other operations are the same as that in the normal weighing mode.



12.2. Unit Weight Registration

- There are three methods to register the unit weight: By weighing the actual samples to determine the unit weight, by digital input of the unit weight, or by command via the serial interface.
- The unit weight is one item of the code memory data. Select the code memory number and start the unit weight registration in the counting mode. The unit weight registration can not be done from the code memory number display.
- The counting accuracy improvement function by re-calculating the unit weight based on the actual weight is not available..

Weigh Actual Samples

When the unit weight is unknown, prepare some samples to determine the unit weight.

Step 1 Enter the counting mode.

Step 2 Press the **SAMPLE** key to enter the unit weight registration mode. $\boxed{5} \boxed{0}$ or $\boxed{5} \boxed{-}$ is displayed and unit pcs blinks. the left side of the display is the number of samples. The right side of the display indicates the weight, $\boxed{0}$ means that the weight is zero and $\boxed{-}$ means that the display is not at zero.

Step 3 Select the number of samples and place the samples specified on the weighing unit. Use the following keys:

$\boxed{0} - \boxed{9}$ key The key to set the number of samples. Maximum is 9999.

$\boxed{+/-}$ key The key to select the number of samples, 5, 10, 20, 50,100.

ZERO key The key to set the zero point.

TARE key The key to tare, when using a container.

ENTER keyThe key to register the unit weight and return to the counting mode. The unit weight is calculated automatically with the weight and the number of samples.

Press **ESC** key while pressing the **+/-** key

The key to return to the counting mode without changing the unit weight.

- Notes**
- It is preferable to have a large number of samples, to minimize the counting error.
 - Press the **ENTER** key after the **STABLE** mark turns on.
 - If the total weight of the samples is too light and is not adequate to be used as the unit weight, **LoUt** is displayed for 2 seconds and returns to the registration display.

Digital Input

When the unit weight is known, digital input is available.

Step 1 Start with the normal weighing mode.

Step 2 Press the **SAMPLE** key. **U xxx** and the unit weight is displayed with unit pcs blinking. Use the following keys:

0 - 9 keyThe key to set the unit weight. Maximum is 5 digits.

+/- key.....The key to select the weight unit of the unit weight.

ZERO keyThe key to clear the digital input. **U - - - -** is displayed.

ESC key.....The key to return to the the weighing mode without changing the registered unit weight.

ENTER keyThe key to register the unit weight and return to the weighing mode.

Press the **MODE** key while pressing **+/-** key....The key to shift the decimal point.

Command Input

When the unit weight is known, command input via the serial interface is available. For details, refer to “13.3. Command Format”.



13. RS-232C Interface (OP-05, OP-08)



13.1. Specification

Transmission	Asynchronous, bi-directional, half-duplex
Baud rate	600, 1200, 2400, 4800, 9600 bps
Data bits	7 bits, 8 bits
Parity bit	1 bit, Even or Odd (for 7 data bits) or Non parity (for 8 data bits)
Start bit	1 bit
Stop bit	1 bit
Code	ASCII
Terminator	CR LF, CR (CR: 0Dh, LF: 0Ah)
Connector	Terminal block

Circuit and Pin Connection

Pin No.	Signal name	Direction	Description
1	TXD	Output	Transmit data
2	RXD	Input	Received data
3	DSR	Output	Data set ready
4	SG	-	Signal ground
5	FG	-	Shield (Frame ground)

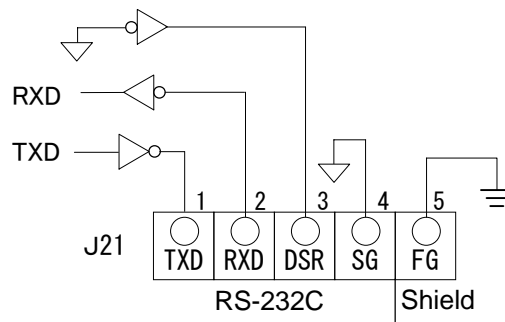

Bit Format

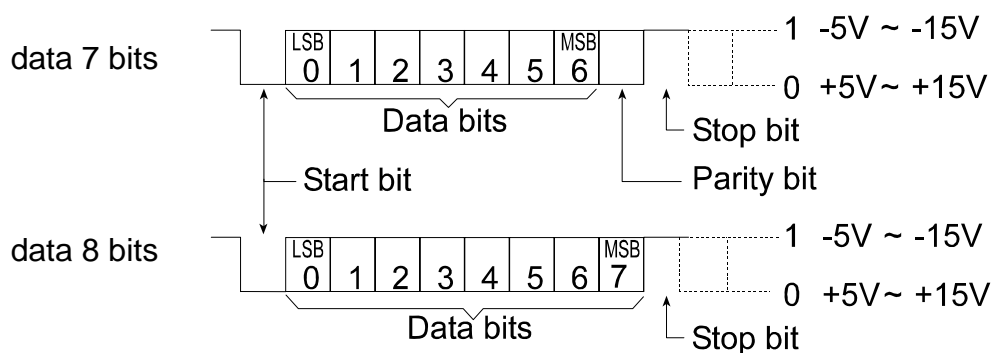



13.2. Data Format

- Two types of data format can be set at F-Function $F34$ and $F35$.
- The initial data format of $F34$ is shown below.

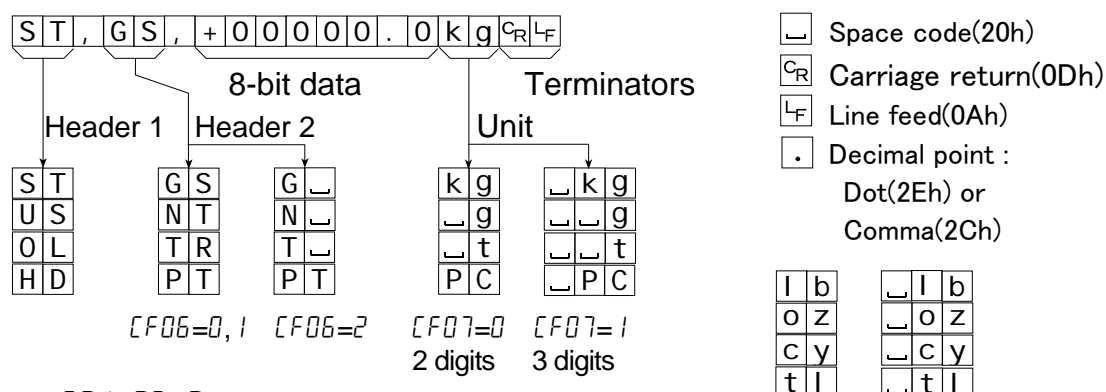

Header 1 $F34, 35=9$ (Status)

- ST St_ab_le weight data
- US Un_us_ta_bl_e weight data
- OL Ove_rl_oa_d (Out of range)
- HD Hel_d weight data (The response of the "RW and "RW,n" command)

Header 2 $F34, 35=E$ (weight type)

- GS or G Gross data
- NT or N Net data
- TR or T Tare data
- PT Preset Tare

Data $F34, 35=A, b, c, d$ (weight data)

The first of the data bits is the polarity, "+" or "-".

When the data is zero, the polarity is "+".

8 bits including polarity and decimal point (dot or comma).

In case of "Out of range", the data are replaced with spaces except the decimal point.

Unit $F34, 35=F$ (unit)

In case of $CF07=0$, the unit length is 2 digits.

In case of $CF07=1$, the unit length is 3 digits. Depending on circumstances, an A&D printer may not work correctly.



13.3. Command Format

Description of Command

- When performing a command, the received command or reply data is sent back.
- When the received command can not be performed such as in the "busy" state, the code " I " is sent back. In this case, insert a delay time. Electrical noise may be the cause of this error.

- When receiving an undefined command (unknown command), a "?" is sent back.
- When the memory is insufficient to store the data of UFC commands, an "M" is sent back.
- Optional addresses can be added to a command. The address form is "@address" and the address is specified at F-Function $F06$. The reply (data or error code) is also sent with the address.

Example: Command is "Display net data". Address is 23.

Sending a command



Sending a command with address

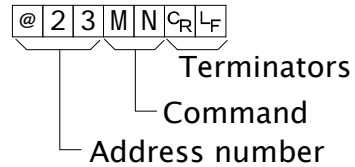

Unperformed command reply

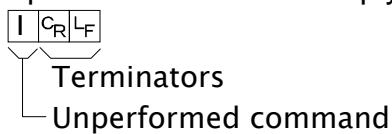

Unknown command reply

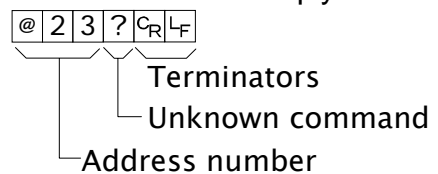

Memory overflow (for UFC commands)

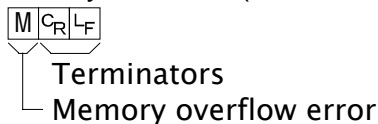

CR Carriage return(0Dh)
LF Line feed(0Ah)

13.3.1. Command to Request Data

Request Display Data (1)

When receiving this command, returns the displayed data immediately.

Template RW

Command $R|W|CR|LF$

Reply $S|T|,|G|S|,|+|0|0|1|2|3|.|0|k|g|CR|LF$

Request Display Data (2)

When receiving this command, returns the displayed data immediately with format 1 or 2.

Template RW,1 or RW,2

Command $R|W|,|1|CR|LF$ or $R|W|,|2|CR|LF$

Reply Format1(F34) or Format2(F35)

Request Gross weight

When receiving this command, returns the gross data immediately.

Template RG

Command $R|G|CR|LF$

Reply $S|T|,|G|S|,|+|0|0|1|2|3|.|0|k|g|CR|LF$

Request Net weight

When receiving this command, returns the net data immediately.

Template RN

Command

R	N	C _R	L _F
---	---	----------------	----------------

Reply

S	T	,	N	T	,	+	0	0	1	2	3	.	0	k	g	C _R	L _F
---	---	---	---	---	---	---	---	---	---	---	---	---	---	---	---	----------------	----------------

Request Tare weight

When receiving this command, returns the tare data immediately.

Template RT

Command

R	T	C _R	L _F
---	---	----------------	----------------

Reply

S	T	,	T	R	,	+	0	0	1	2	3	.	0	k	g	C _R	L _F
---	---	---	---	---	---	---	---	---	---	---	---	---	---	---	---	----------------	----------------

Request Accumulated Data

When receiving this command, returns the accumulated data immediately.

Template RA

Command

R	A	C _R	L _F
---	---	----------------	----------------

Reply Refer to the Fixed data format of “8.2. Display and Operation, Output of Accumulated data”.

Is Zero

When receiving this command, returns “at zero point” or no immediately.

Template RZ

Command

R	Z	C _R	L _F
---	---	----------------	----------------

Reply

1	C _R	L _F
---	----------------	----------------

 when at ZERO

0	C _R	L _F
---	----------------	----------------

 Not at ZERO

13.3.2. Commands to Control the Indicator

Zero Display

Sets the current display to the zero point.

Template MZ

Command

M	Z	C _R	L _F
---	---	----------------	----------------

Reply

M	Z	C _R	L _F
---	---	----------------	----------------

Tare

Sets the current display to zero of the net data.

Template MT

Command

M	T	C _R	L _F
---	---	----------------	----------------

Reply

M	T	C _R	L _F
---	---	----------------	----------------

Clear Tare Data

Clears the tare data and displays the gross data_.

Template CT

Command

C	T	C _R	L _F
---	---	----------------	----------------

Reply

C	T	C _R	L _F
---	---	----------------	----------------

Display Gross Data

Displays the gross data.

Template MG

Command

M	G	C _R	L _F
---	---	----------------	----------------

Reply

M	G	C _R	L _F
---	---	----------------	----------------

Display Net Data

Displays the net data.

Template MN

Command

M	N	C _R	L _F
---	---	----------------	----------------

Reply

M	N	C _R	L _F
---	---	----------------	----------------

Accumulation (M+)

Accumulates the displayed data.

Template MA

Command

M	A	C _R	L _F
---	---	----------------	----------------

Reply

M	A	C _R	L _F
---	---	----------------	----------------

Clearing the Accumulated data

Clears the accumulated data.

Template CA

Command

C	A	C _R	L _F
---	---	----------------	----------------

Reply

C	A	C _R	L _F
---	---	----------------	----------------

Changing the Weight Unit

Changes the weight unit.

Template UC

Command

U	C	C _R	L _F
---	---	----------------	----------------

Reply

U	C	C _R	L _F
---	---	----------------	----------------

Changing the Code Memory

Changes the code memory number.

Template SC,m

m: code memory number, 0 - 4

Command

S	C	,	4	C _R	L _F
---	---	---	---	----------------	----------------

Reply

S	C	,	4	C _R	L _F
---	---	---	---	----------------	----------------

Disabling Key Switches

Disables the key switches. Once power off, no effect remains by this command.

Template DK,n

n: key switch number (0: all keys, 1 - F: refer F-Function *F 12*)

Command

D	K	,	4	C _R	L _F
---	---	---	---	----------------	----------------

Example: to disable TARE key

Reply

D	K	,	4	C _R	L _F
---	---	---	---	----------------	----------------

Enabling Key Switches

Enables the key switches that are disabled by the DK command. Not applicable to the keys disabled by F_{12} .

Template EK,n

n: key switch number (0: all keys, 1 - F: refer F-Function F_{12})

Command

E	K	,	0	C _R	L _F
---	---	---	---	----------------	----------------

Example: to enable all keys

Reply

E	K	,	0	C _R	L _F
---	---	---	---	----------------	----------------

13.3.3. Commands to Set Parameters

Set Limit/Setpoint Value

Sets the limit or setpoint value of the comparison. The decimal point is not necessary.

Template S_m,n, [value]

m: code memory number, 0 - 4

n: setpoint order number. Refer to "10.1.2. Setting the Upper/Lower Limit values" and "10.2.3. Setting the Parameters of Setpoint Comparison."

Command

S	1	,	3	,	+	1	6	0	C _R	L _F
---	---	---	---	---	---	---	---	---	----------------	----------------

Reply

S	1	,	3	,	+	1	6	0	C _R	L _F
---	---	---	---	---	---	---	---	---	----------------	----------------

Set Zero Band

Sets the F_{26} value (zero band) of the comparison. The decimal point is not necessary.

Template SZ, [value]

Command

S	Z	,	+	7	4	8	C _R	L _F
---	---	---	---	---	---	---	----------------	----------------

Reply

S	Z	,	+	7	4	8	C _R	L _F
---	---	---	---	---	---	---	----------------	----------------

Set Preset Tare

Sets the preset tare value. The decimal point is not necessary.

Template PT,m, [value]

m: code memory number, 0 - 4

Command

P	T	,	2	,	2	1	3	C _R	L _F
---	---	---	---	---	---	---	---	----------------	----------------

Reply

P	T	,	2	,	2	1	3	C _R	L _F
---	---	---	---	---	---	---	---	----------------	----------------

Set Unit Weight for Counting Mode

Sets the unit weight value with decimal point.

Template UW,m, [value]

m: code memory number, 0 - 4

Command

U	W	,	2	,	2	1	.	3	C _R	L _F
---	---	---	---	---	---	---	---	---	----------------	----------------

Reply

U	W	,	2	,	2	1	.	3	C _R	L _F
---	---	---	---	---	---	---	---	---	----------------	----------------

13.3.4. Commands for Hold Function

Start Averaging to Hold

Starts averaging to hold. The reply differs with the conditions.

Template HS

Command

H	S	C _R	L _F
---	---	----------------	----------------

Reply

H	S	C _R	L _F
---	---	----------------	----------------

 Averaging start

H	D	,	1	C _R	L _F
---	---	---	---	----------------	----------------

 Averaging now

H	D	,	2	C _R	L _F
---	---	---	---	----------------	----------------

 Hold

Release the Hold Data

Release the hold data or stop averaging and goes to the normal weighing mode.

Template HC

Command

H	C	C _R	L _F
---	---	----------------	----------------

Reply

H	C	C _R	L _F
---	---	----------------	----------------

Request Hold State

When receiving this command, returns the average/hold state immediately.

Template HD

Command

H	D	C _R	L _F
---	---	----------------	----------------

Reply

H	D	,	0	C _R	L _F
---	---	---	---	----------------	----------------

 Not hold nor averaging

H	D	,	1	C _R	L _F
---	---	---	---	----------------	----------------

 Averaging now

H	D	,	2	C _R	L _F
---	---	---	---	----------------	----------------

 Hold

13.3.5. Commands to Set Serial Data Output Format (UFC)

Set Serial Data Format

Sets the serial output data format.

Format 1 (2) data is stored in the same memory area of *F34* (*F35*).

Template SFf, [parameters]

f: Format number, 1 or 2

Command

S	F	1	,	\$	G	R	C _R	L _F
---	---	---	---	----	---	---	----------------	----------------

Reply

S	F	1	,	\$	G	R	C _R	L _F
---	---	---	---	----	---	---	----------------	----------------



13.4. UFC Command

- UFC (Universal Flexi Coms) function enables editing the serial data output format freely using the serial interface command.
- For customizing the printout of the printer or efficient data collection.
- Output data is not only the indicator's data/status but also characters at will.
- It can output the control code* of the printer. (* depends on the individual printer)
- There are 2 set of memories for storing the parameters.

UFC Command Parameter

UFC commands such as SF1 have many parameters.

- One command line can have a multiple number of parameters. The parameters are stored in memory in order.
- Multiple UFC commands are possible. The parameters are stored next to the last parameter stored by the last UFC command.
- Clear all of the data first, if storing a new set of parameters. The parameters in the stored data can not be changed partially.
- The various types of parameters and their descriptions are shown below.

data	Weight, result of comparison etc.
\$CL	Clear previous settings. UFC command parameters can not be changed partially.
\$WT	Displayed data
\$GR	Gross data
\$NT	Net data
\$TR	Tare data
\$HD	Header of Gross/Net/Tare or Preset tare. Refer to CF06.
\$UT	Weight Unit
\$ST	Stable/Unstable
\$CP	Result of Comparison
\$ID	ID number specified at F06
\$DN	Data Number increments with each output automatically
\$CD	Code memory number
\$AN	Accumulation count
\$TL	Total weight
\$CM	Command
\$CR	CR code (0Dh)
\$LF	LF code (0Ah)
\$DE	Delete the last parameter
\$DL	Inserting Delay time (0.1 second step) Example: DL10: 1.0 second delay

strings

Output the specified strings, enclosed by a single quotation (').

' itself is described using three single quotations; '''.

Example: 'A & D' 'This is a sample of '''.'

Set data bits = 8 bits if using the 8-bit characters.

hexadecimal

Control code of the printer etc, preceded by #.

2 characters preceded by # is hexadecimal code.

Example: #09, #7C

The #FF code can not be used because it is used for internal control.

□ Example

SF1,\$ID\$DN\$CR\$LF\$GR\$UT\$CR\$LF

Serial output data format 1, ID number, data number, carriage return and line feed, Gross weight, unit, carriage return and line feed.

SF2,' Welcome to A & D'\$LF'Total weight '\$AN\$TL\$LF\$LF

Serial output data format 2, the strings ' Welcome to A & D' and line feed, the strings 'Total weight ' accumulation count, total weight, and 2 sets of line feed.



14. RS-422/RS-485, Relay Output(OP-03)

- Replacing the RS-232C interface with this option, the RS-422/RS-485 interface can connect up to 32 indicators and control them from a computer or a PLC.
- The functions of RS-422/RS-485 interface are common to RS-232C except for the signal system.
- The relays output the result of comparison.

Solid-state-relay

Maximum voltage 50VDC

Maximum current 100 mA DC

Maximum resistance 8 Ω

Pin connections and Circuits

Function	Pin No.	Signal name	Direction	Description
RS-422 RS-485	1	SDA	Output	Transmission A terminal
	2	SDB	Output	Transmission B terminal
	3	RDA	Input	Receive A terminal
	4	RDB	Input	Receive B terminal
	5	TRM	-	Terminator resistor (100 Ω)
Relay output	6	HI	Output	Relay output HI
	7	OK	Output	Relay output OK
	8	LO	Output	Relay output LO
	9	COM	-	Relay output common

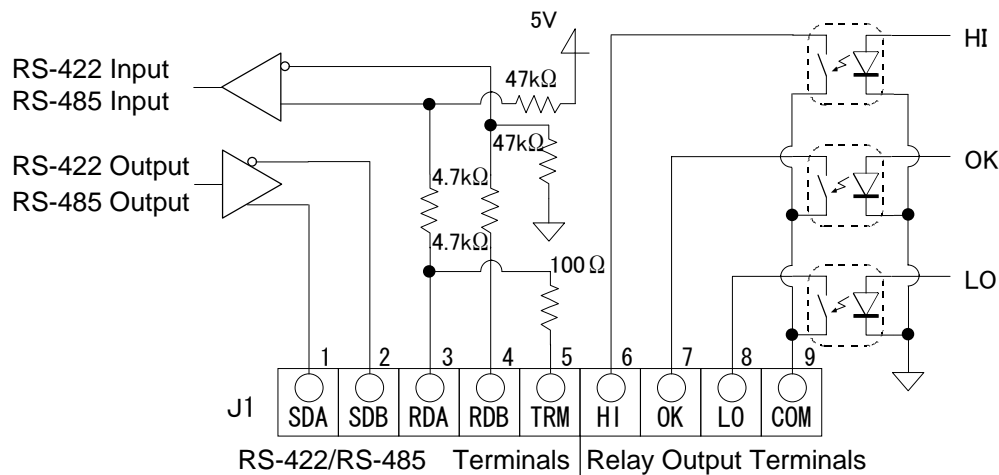

Adaptable connector

TM-BLA9 (provided with the OP-03)

Switching Between RS-422/RS-485

Switching between RS-422/RS-485 is made with the slide switch (SW1) on the OP-03 board.

Connection

- The polarity of signals A and B may vary with different computers.
- It is not necessary to ground the SG terminal when using a computer without a signal ground terminal.

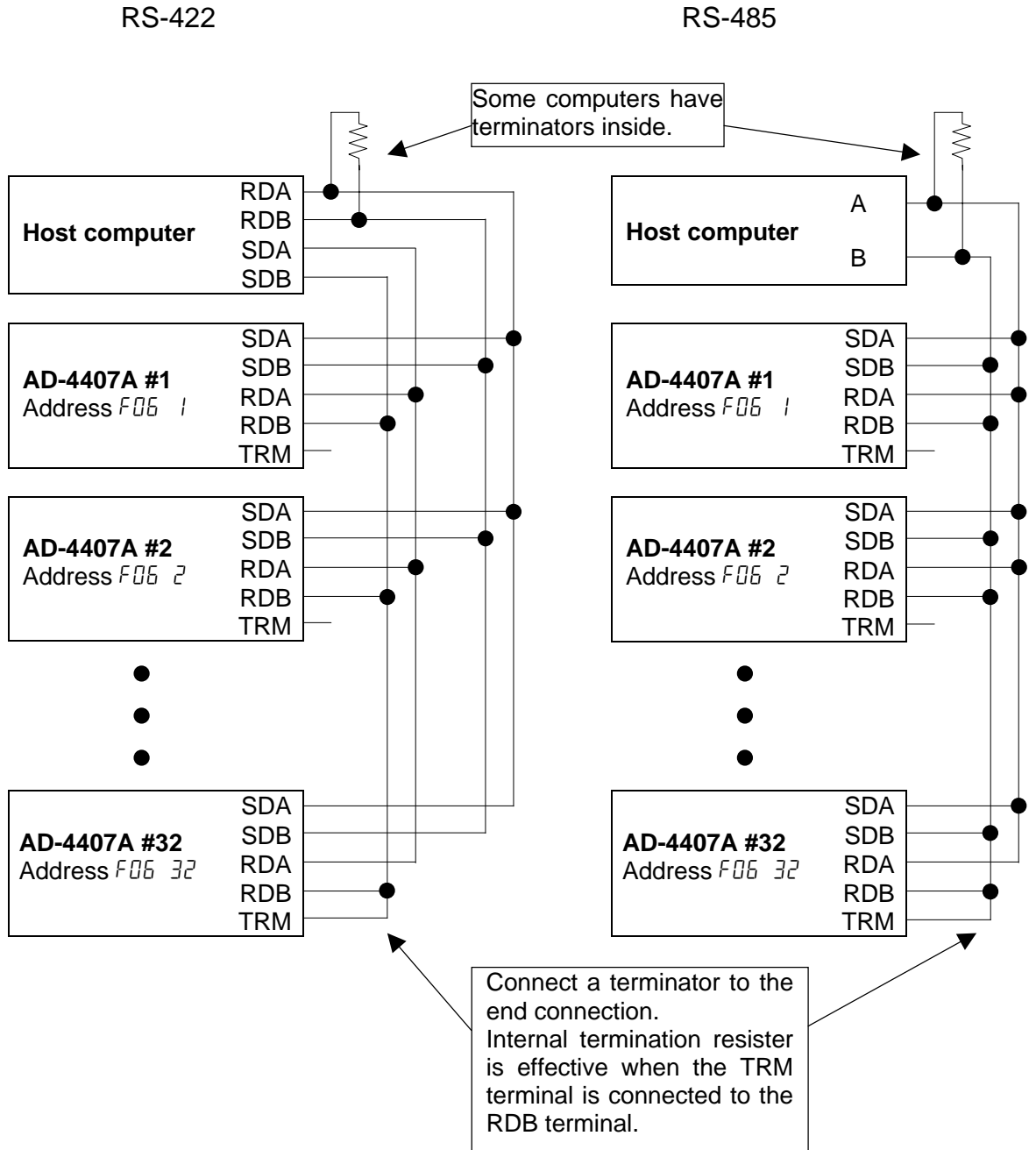



15. Relay Output and Control Input (OP-05)

- Replacing the RS-232C interface with this option, 3-relay outputs and 3-control inputs can be used with the RS-232C interface of this option.
- RS-232C functions are the same as the RS-232C interface described in “13. RS-232C Interface”.
- The solid state relays output the result of comparison.
- The control inputs can control the indicator from an external terminal just like the front panel key operations.
- Set the external control functions at *F 13* - *F 15* of the F-Functions.
- When connecting each function pin to the common pin, the indicator makes the action.
- Keep a signal width of more than 100 ms for the On-time and Off-time.

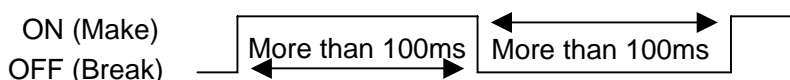

Pin connections and Circuits

Function	Pin No.	Signal name	Direction	Description
RS-232C	1	TXD	Output	Transmit data
	2	RXD	Input	Received data
	3	DSR	Output	Data set ready
	4	SG	-	Signal ground
Relay output	5	HI	Output	Relay output HI
	6	OK	Output	Relay output OK
	7	LO	Output	Relay output LO
	8	COM(out)	-	Relay output common
Control input	9	EXT1	Input	Control input 1 (<i>F 13</i>)
	10	EXT2	Input	Control input 2 (<i>F 14</i>)
	11	EXT3	Input	Control input 3 (<i>F 15</i>)
	12	COM(in)	-	Control input common
FG	13	FG	-	Frame ground (case)

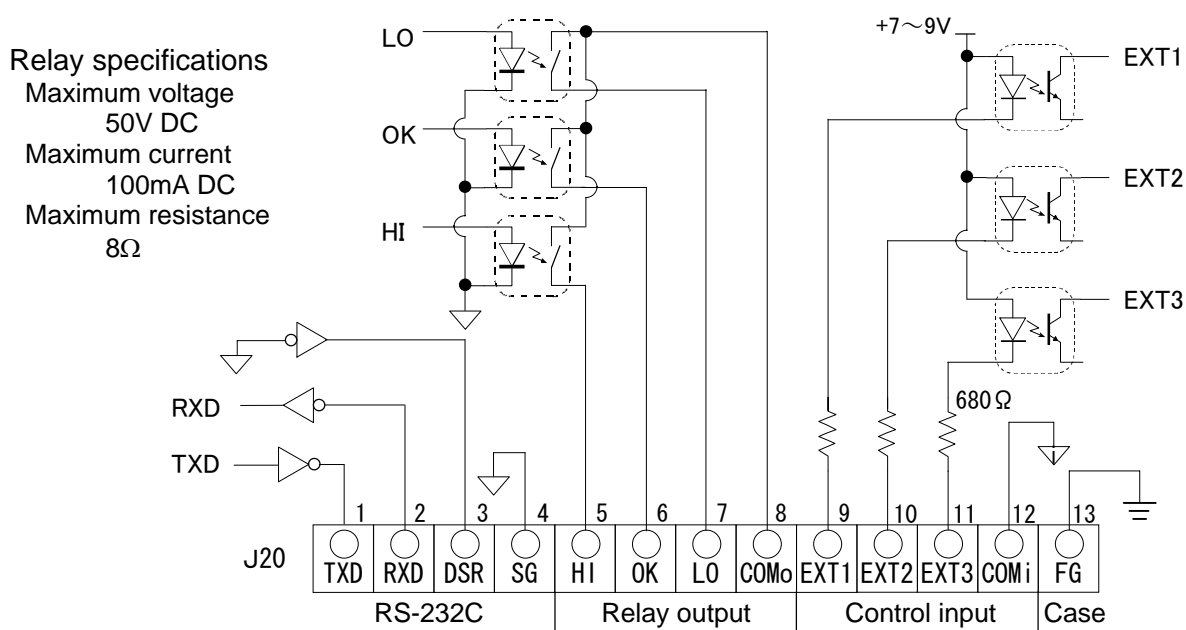

Relay specifications
 Maximum voltage
 50V DC
 Maximum current
 100mA DC
 Maximum resistance
 8Ω



16. 4–20mA Analog Output (OP-07)

- The OP-07 analog output option is for sending the weight data to an analog input unit.
- The output is a 4mA to 20mA current output proportional to the display reading.
- The output data is updated in synchronization with the display update.

Specifications

Output current	4mA to 20mA *	Non-linearity		Less than +/- 0.1% fs
Load resistance	0 to 510 Ω	Temperature	ZERO	Less than +/- 0.02% fs/°C
Resolution	Approx. 1/10000	coefficient	SPAN	
Output terminal	Connector terminal	No.1 : +	No.2 : -	No.3 : FG(Earth)

* When set to a non-weight display (Calibration, F-settings etc.), the output current is 4mA.

The output current is not adjustable.

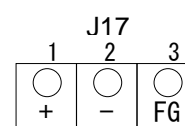

Analog output terminal

Settings

Set *F30* to 1 of the F-Function, and set *F31* to *F33*.

	Item	Parameter	Remarks	
Data output	<i>F30</i> Data output	* 0	No output	Initial setting
		1	Analog output	Must be set to 1
		2	Serial in/out 1	
		3	Serial in/out 2	
Analog output	<i>F31</i> Output data	* 0	Displayed value	Initial setting
		1	GROSS weight	
		2	NET weight	
	<i>F32</i> Weight value at 4mA	-999999 to 999999 (Initial setting is 0)	Decimal point is set at <input type="text" value="CALSET"/>	
	<i>F33</i> Weight value at 20mA	-999999 to 999999 (Initial setting is 10000)	Decimal point is set at <input type="text" value="CALSET"/>	

Settings of *F32* and *F33*

When entering the *F32* or *F33* settings (press the key when "32" or "33" is blinking), the setting value is displayed. Set the value using the 0 - 9 key. By pressing the key, the polarity of the value can be alternated. Press the key to store the setting value into memory. After this the display returns to selection of the Function number.

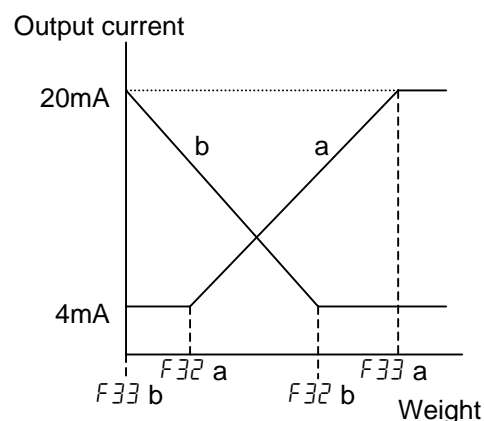



17. Current Loop Output (OP-08)

- Replacing the RS-232C interface with this option, current loop output, 3-relay outputs and 1-control input can be used with the RS-232C interface of this option.
- RS-232C functions are the same as the RS-232C interface described in “13. RS-232C Interface”.
- The solid state relays output the result of comparison.
- The control input can control the indicator from an external terminal just like the front panel key operations.
- Set the external control function at F15 of the F-Functions.
- When connecting the function pin and the common pin, the indicator makes the action.
- Keep a signal width of more than 100 ms for the On-time and Off-time.

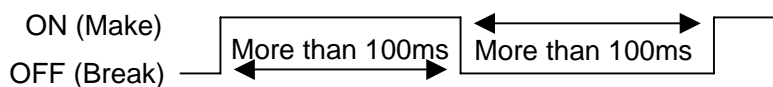

Pin connections and Circuits

Function	Pin No.	Signal name	Direction	Description
RS-232C	1	TXD	Output	Transmit data
	2	RXD	Input	Received data
	3	DSR	Output	Data set ready
	4	SG	-	Signal ground
Relay output	5	HI	Output	Relay output HI
	6	OK	Output	Relay output OK
	7	LO	Output	Relay output LO
	8	COM(out)	-	Relay output common
Current loop	9	CL1	Output	Current loop output 1
	10	CL2	Output	Current loop output 2
Control input	11	EXT3	Input	Control input 3 (F15)
	12	COM(in)	-	Control input common
FG	13	FG	-	Frame ground (case)

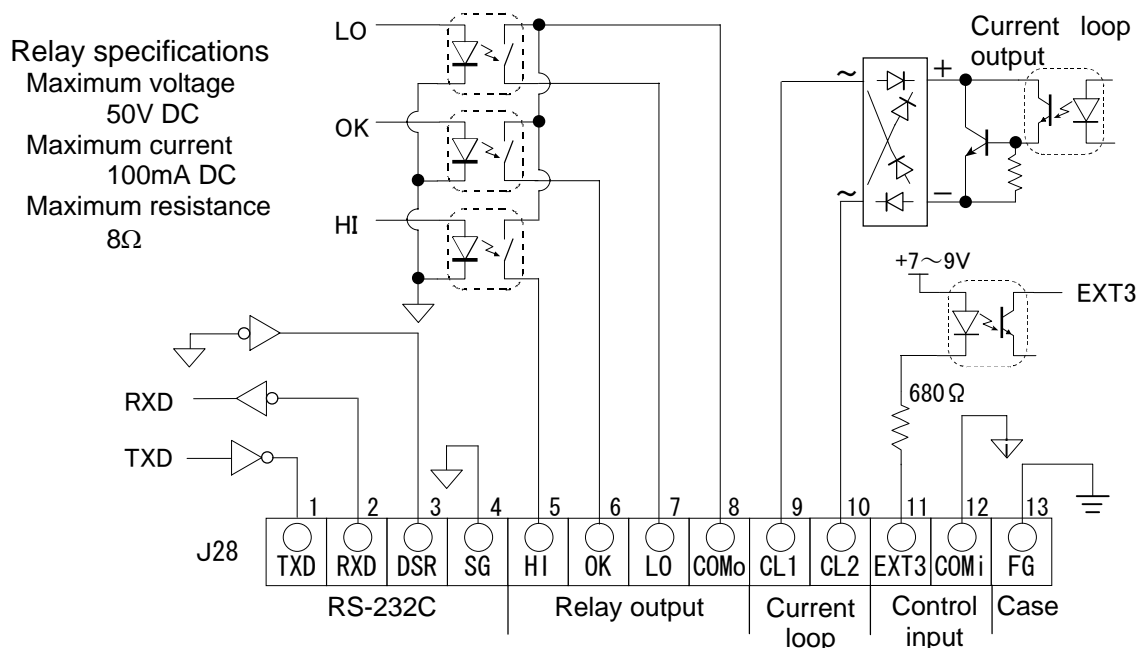

Current Loop Output

- The current loop output can be used to output the data to an A&D printer and a display unit.
- The current loop output is of the passive type and requires an external current source of 20 mA current. A&D's printer and display unit can be connected without an external power source, because they supply the current.
- The output terminals do not have a polarity. Each output terminal can be connected to either the plus or minus inputs of the peripheral unit.
- Set *F36*, *F37*, *F38* and *F39* of F-Functions. Please note the initial setting of *F37* is disabling the current loop output.

Data format

- The data format is the same as that of the initial setting of *F34* of RS-232C data format.
- The current loop output data format is fixed and can not be changed.
- The header 2 and the unit selection are common to RS-232C (*CF06*, *CF07*).

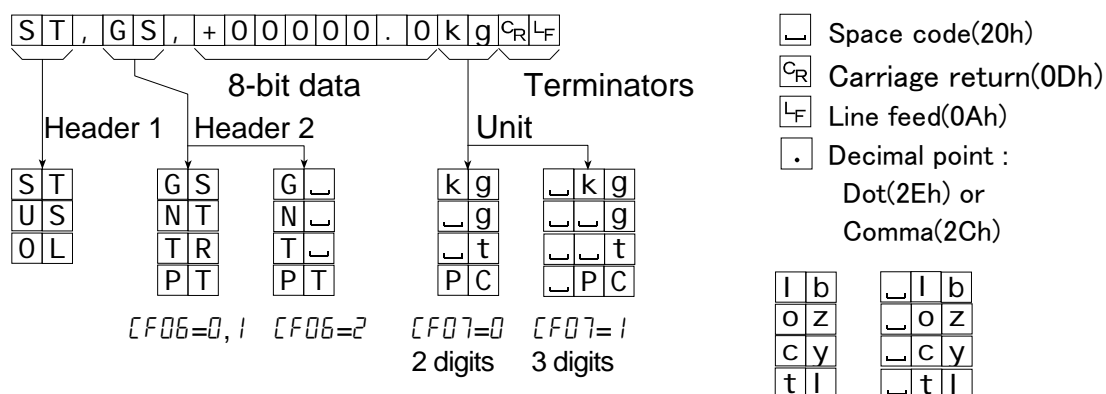



18. Specifications

Analog Input and A/D Conversion

Input sensitivity	0.15 μ V/division	
Input signal range	-35 mV to +35 mV	
Load cell excitation voltage	5V DC \pm 5%, 120 mA with sense voltage input	
Load cell drive capacity	Maximum 8 x 350 Ω load cells	
Temperature coefficient	Zero	\pm 0.02 μ V/ $^{\circ}$ C (typ.) \pm 0.1 μ V/ $^{\circ}$ C (max.)
	Span	\pm 3ppm/ $^{\circ}$ C (typ.) \pm 15ppm/ $^{\circ}$ C (max.)
Non-Linearity	0.005 % of full scale	
Maximum input noise	0.15 μ Vp-p (typ.)	
Input impedance	10 M Ω or more	
A/D conversion method	Delta-sigma method	
A/D resolution count	40000 counts	
A/D conversion rate and display update rate	Approximately 10 times/s	
Maximum display resolution	20000 (permissible 40000)	

Digital Section

Measurement display	7 segment, Vacuum fluorescent display tube	
	Character color	Cobalt-blue
	Character height	20 mm
State indicator Symbol	Minus sign, Zero point, Stable, Net, Preset tare value, Storing accumulated data, Percentage, Various state indicator (triangle \blacktriangledown 1,2,3)	
	Character color	Cobalt-blue
Comparison result	HI, OK, LO	
	Character color	Red for HI and LO, Green for OK
Unit	kg, g, t (lb, oz, lb-oz / catty, tl, catty-tl : depends on the region)	
	Character color	Cobalt-blue

Interface

RS-232C interface	Serial interface for communication (terminal block)
RS-422/485 interface	Serial interface for communication, control (terminal block)
Current Loop output	20mA, passive type (terminal block)
Analog output	4-20mA, free scaling output (terminal block)
External Control Input	3 or 1 input selected functions (terminal block)
Relay output	3 point (terminal block)
	Capacity: 50V AC/DC, maximum current 100mA (resistive load)
	Comparison mode selection
	HiHi, Hi, OK, Lo, LoLo output for limit comparison
	Zero band, preliminary, free fall, final for setpoint comparison



A&D Company, Limited

3-23-14 Higashi-Ikebukuro, Toshima-ku, Tokyo 170-0013 JAPAN
Telephone: [81] (3) 5391-6132 Fax: [81] (3) 5391-6148

A&D ENGINEERING, INC.

1756 Automation Parkway, San Jose, California 95131 U.S.A.
Telephone: [1] (408) 263-5333 Fax: [1] (408)263-0119

A&D INSTRUMENTS LIMITED <UK Office>

Unit 24/26 Blacklands Way, Abingdon Business Park, Abingdon, Oxfordshire
OX14 1DY United Kingdom
Telephone: [44] (1235) 550420 Fax: [44] (1235) 550485

A&D INSTRUMENTS LIMITED <German Sales Office>

Große Straße 13 b 22926 Ahrensburg Deutschland
Telefon: [49] (0) 4102 459230 Telefax: [49] (0) 4102 459231

A&D Australasia Pty Ltd.

32 Dew Street, Thebarton, South Australia 5031 AUSTRALIA
Telephone: [61] (8) 8301-8100 Fax: [61] (8) 8352-7409

A&D KOREA Limited

한국에이.엔.디(주)
대한민국 서울시 영등포구 여의도동 36-2 맨하탄 빌딩 8층
(8th Floor, Manhattan Bldg. 36-2 Yoido-dong, Youngdeungpo-ku, Seoul, KOREA)
전화: [82] (2) 780-4101 팩스: [82] (2) 782-4280

A&D RUS CO., LTD.

Компания Эй энд Ди Рус
121357, Российская Федерация, г.Москва, ул. Верейская, дом 17
(Bldg. 17, Vereyskaya st., Moscow, 121357 RUSSIAN FEDERATION)
тел.: [7] (495) 937-33-44 факс: [7] (495) 937-55-66

A&D Instruments India Private Limited

ऐ&डी इन्स्ट्रूमेन्ट्स इण्डिया प्रा० लिमिटेड
509, उद्योग विहार , फेस -5, गुडगांव - 122016, हरियाणा , भारत
(509, Udyog Vihar, Phase-V, Gurgaon - 122 016, Haryana, India)
फोन : 91-124-4715555 फैक्स : 91-124-4715599