

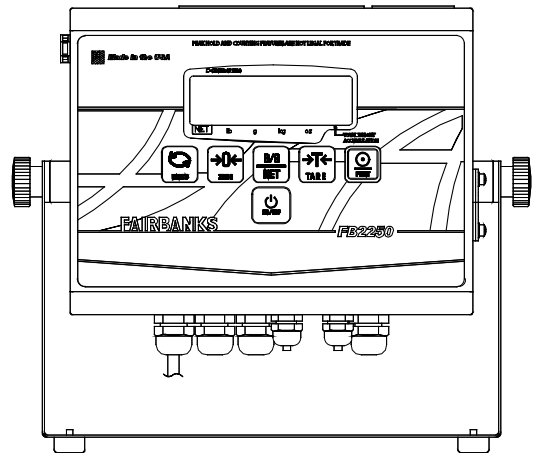

FB2250 Series Instrument PC2250 Utility Software

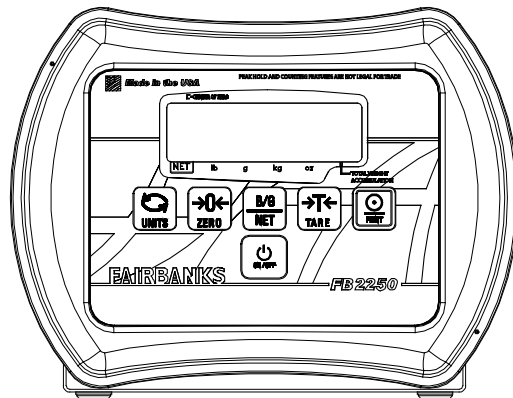

Amendment Record

FB2250 Series Instrument PC2250 Utility Software Document 51214

Manufactured by **Fairbanks Scales Inc.**

Created	03/2009	
Revision 1	03/2009	Released Manual
Revision 2	05/2009	Added CC and ETL Approvals
Revision 3	06/2009	Added MC Approval, IP69K, and Panel Mount Models
Revision 4	07/2009	Added power on/off instruction
Revision 5	03/2010	Updated for Rev 2 Software
Revision 6	05/2011	Added fieldbus information.
Revision 7	06/2012	Added PC2250 information.
Revision 8	08/2013	Corrected grammatical errors and clarification of charts.
Revision 9	05/2015	Updated battery specifications, product names, 4-20mA definitions, and added ControlNet information. Added FB225X TCP configuration instructions.
Revision 10	08/2015	Updated Fieldbus information
Revision 11	08/2016	Added Modbus to Fieldbus information
Revision 12	03/2016	Updated Weight Accumulation
Revision 13	04/2016	Added TM-U220 Tape Printer Information
Revision 14	08/2019	Updated 4-20mA programming steps
Revision 15	10/2019	Added 4-20mA "Warning" information
Revision 16	02/2020	Updated Accessories > Fieldbus links
Revision 17	08/2020	Updated Weight Accumulation

Disclaimer

Every effort has been made to provide complete and accurate information in this manual. However, although this manual may include a specifically identified warranty notice for the product, Fairbanks Scales makes no representations or warranties with respect to the contents of this manual, and reserves the right to make changes to this manual without notice when and as improvements are made.

It is the responsibility of the requesting party to develop, maintain, install, and connect networking devices and general network connectivity as it applies to the originating party's network. No warranty or guarantee, expressed or implied, concerning the network, its design, its installation, or operational characteristics has been offered by Fairbanks Scales.

Fairbanks Scales shall not be liable for any loss, damage, cost of repairs, incidental or consequential damages of any kind, whether or not based on express or implied warranty, contract, negligence, or strict liability arising in connection with the design, development, installation, or use of an intended network or scale instrument.

The Bluetooth® word mark and logos are owned by the Bluetooth SIG, Inc. and any use of such marks by Fairbanks Scales is under license. Other trademarks and trade names are those of their respective owners.

© Copyright 2009-2020

This document contains proprietary information protected by copyright. All rights are reserved; no part of this manual may be reproduced, copied, translated, or transmitted in any form or by any means without prior written permission of the manufacturer.

TABLE OF CONTENTS

SECTION 1: GENERAL INFORMATION.....	7
1.1. Model Descriptions	7
1.2. Main Product Features	7
1.3. Specifications	8
1.3.1. <i>Instrument Approvals.....</i>	8
1.3.2. <i>Specifications.....</i>	8
1.3.3. <i>Settings.....</i>	9
1.3.4. <i>Weight Accumulator.....</i>	9
1.3.5. <i>Outputs</i>	9
1.3.6. <i>AC Operation</i>	9
1.3.7. <i>DC Models</i>	10
1.3.8. <i>Out of Range Warnings</i>	10
1.3.9. <i>External Printers</i>	10
1.3.10. <i>Environment.....</i>	10
1.3.11. <i>PC2250.....</i>	10
1.3. Accessories	11
1.4. Battery Installation	11
1.5. Powering up the FB2250	12
1.6. Flow Charts.....	12
SECTION 2: FRONT PANEL PROGRAMMING.....	13
2.1. Front Panel Programming Parameters.....	13
2.2. Front Panel Programming.....	14
2.2.1. <i>Programming and Setting Time.....</i>	14
2.2.2. <i>Programming the Date.....</i>	14
2.2.3. <i>Display Battery Voltage</i>	15
2.2.4. <i>Programming the Sleep Function</i>	15
2.2.5. <i>Clearing the Accumulator</i>	15
2.2.6. <i>Display Operating Mode Data</i>	16
2.2.7. <i>4-20mA Output Setup.....</i>	16
2.2.8. <i>Programming the 4-20mA Analog Output Weighing Mode</i>	17
2.2.9. <i>Programming the 4mA Weight Value</i>	17
2.2.10. <i>Programming the 20mA Weight Value</i>	18
SECTION 3: OPERATION.....	19
3.1. Setup Menu Programming Parameters – Version 2.0+	19
3.2. Setup Menu Programming	20
3.2.1. <i>Programming and Setting Time.....</i>	20
3.2.2. <i>Programming the Date.....</i>	20
3.2.3. <i>Programming Port 1.....</i>	21
3.2.4. <i>Programming the Port 1 Output Type.....</i>	21
3.2.5. <i>Programming Port 1 Baud Rate</i>	22
3.2.6. <i>Programming Port 1 Data Bits.....</i>	22
3.2.7. <i>Programming Port 1 Parity Setting</i>	22
3.2.8. <i>Programming Port 1 Stop Bits</i>	23
3.2.9. <i>Programming Port 2.....</i>	23
3.2.10. <i>Programming the Port 2 Output Type.....</i>	23
3.2.11. <i>Programming Port 2 Baud Rate</i>	24
3.2.12. <i>Programming Port 2 Data Bits.....</i>	24
3.2.13. <i>Programming Port 2 Parity Setting</i>	24
3.2.14. <i>Programming Port 2 Stop Bits</i>	25
3.2.15. <i>Programming the Back Light Options.....</i>	25
3.2.16. <i>Programming the Back Light Timing</i>	25



- 3.3. Configuration Menu Programming Parameters..... 26**
 - 3.3.1. *Programming the Scale Capacity..... 27*
 - 3.3.2. *Programming the Scale Units..... 27*
 - 3.3.3. *Programming the Primary Unit..... 28*
 - 3.3.4. *Programming the Automatic Zero Tracking Band..... 28*
 - 3.3.5. *Programming the Motion Band..... 28*
 - 3.3.6. *Programming the Zero Range..... 29*
 - 3.3.7. *Programming the Division Size..... 29*
 - 3.3.8. *Programming the Filter Setting..... 29*
 - 3.3.9. *Programming the Tare Setting..... 30*
 - 3.3.10. *Programming the Display Update Rate..... 30*
- 3.4. Application Menu Programming Parameters..... 31**
 - 3.4.1. *Microvolts Per Division..... 31*
 - 3.4.2. *Programming the 4-20mA Analog Output..... 31*
 - 3.4.3. *Programming the Piece Count Feature..... 32*
 - 3.4.4. *Programming the Accumulator Feature..... 32*
 - 3.4.5. *Programming the Peak Hold Feature..... 32*
- 3.5. Operating Mode..... 33**
 - 3.5.1. *Front Panel Key Functions..... 33*
 - 3.5.2. *Operating Procedures..... 34*
 - 3.5.3. *Instrument Weighing Functions..... 35*
 - 3.5.4. *Basic Weighing..... 35*
 - 3.5.5. *Gross Weighing..... 35*
 - 3.5.6. *Net Weighing..... 35*
 - 3.5.7. *Gross/Tare/Net Weighing..... 36*
- 3.6. Weight Accumulation..... 36**
 - 3.6.1. *Weight Accumulation..... 36*
 - 3.6.2. *Printing Weight Accumulations..... 37*
 - 3.6.3. *Number of Accumulations..... 40*
 - 3.6.4. *Clearing the Accumulators..... 40*
 - 3.6.5. *Piece Counting..... 41*
 - 3.6.6. *Piece Count and Total..... 41*
 - 3.6.7. *Peak Weight..... 42*
 - 3.6.8. *Display Total Number of Pieces..... 43*
- SECTION 4: ACCESSORIES..... 44**
 - 4.1. Attaching an external power supply..... 44**
 - 4.1.1. *Requirements..... 44*
 - 4.1.2. *Programming the Weigh Mode that the Output Tracks..... 44*
 - 4.1.3. *Programming the 4mA Weight Value..... 45*
 - 4.1.4. *Programming the 20mA Weight Value..... 45*
 - 4.2. Fieldbus..... 46**
 - 4.2.1. *ETHERNET/IP Addressing..... 46*
 - 4.3. Fieldbus Connections..... 47**
 - 4.4. PROFIBUS®-DP Diagnostic LEDs:..... 50**
 - 4.5. DeviceNet™ Diagnostic LEDs:..... 51**
 - 4.6. Modbus® Diagnostic LEDs:..... 51**
 - 4.7. ETHERNET / IP Diagnostic LEDs:..... 52**
 - 4.8. ControlNet..... 53**
- SECTION 5: SERIAL COMMUNICATION WIRING..... 55**
 - 5.1. JP3 Jumper Configuration:..... 55**
 - 5.2. TB4 Connections, COM1 (A), COM2 (B), and COM2 (C)..... 55**
- SECTION 6: PRINTER INSTALLATION..... 56**



- 6.1. 3550 Tape Printer..... 56
- 6.2. TM-U220 Tape Printer..... 56
- 6.3. Okidata 186 T Form Printer..... 57
- 6.4. Okidata 420 Form Printer 61
- 6.5. TM-U295 Ticket Printer..... 64
- 6.6. TM-U590 Ticket Printer..... 65
- 6.7. 1600 Series Remote Display 66
- 6.8. FB2250 Remote Display 67
- SECTION 7: PC2250 UTILITY SOFTWARE 68**
- 7.1. Introduction 68
- 7.2. Wiring..... 68
- 7.3. Communication Settings 68
- 7.4. Menu Bar 70
- 7.5. Configuration..... 72
- 7.6. Calibration..... 73
- 7.7. First time Connection Using PC225X PC Utility and FB225X ETHERNET TCP/IP option..... 74
- 7.8. Fieldbus..... 78
- 7.9. 4-20mA 81
- 7.10. Custom Output: Settings 82
- 7.11. Custom Output: Load..... 83
- 7.12. Custom Output: Build 84
- 7.13. Custom Output: Tokens..... 85
- 7.14. Custom Output: Weights 87
- 7.15. Format tickets..... 88
- 7.16. Printed Examples: 89
- APPENDIX I: DATA OUTPUT FORMATS 92**
- A. General Notes 92
- B. Fairbanks/ Toledo Continuous Output..... 92
- B. Cardinal 738 Continuous Scoreboard Output 95
- C. Weightronics WI-120 Continuous Output 95
- D. Condec Continuous Output..... 96
- E. Demand Output - Default 96
- F. Continuous Output - Default..... 97
- G. PLC (Do not use.) 98
- H. UPS..... 99
- I. P Ship 100
- I. P Ship, Continued..... 101
- APPENDIX II: ASCII CHART..... 102**
- APPENDIX III: FB2250 REMOTE DISPLAY WIRING 103**
- APPENDIX IV: REMOTE DISPLAY ACTIVE KEYS..... 104**
- APPENDIX V: REMOTE PC COMMANDS 105**
- APPENDIX VI: FB2250 PANEL MOUNT DIMENSIONS..... 106**

SECTION 1: GENERAL INFORMATION

1.1. Model Descriptions

The FB2250 is a general-purpose weighing instrument that can be used with a wide variety of platforms and load receivers and is available in nine (9) different configurations.

MODEL	PART NO.
• FB2250 Series ABS, AC Power	29250
• FB2250 Series ABS, AC/Battery Power	29561
• FB2250 Series SS, AC Power	29251
• FB2250 Series SS, AC/Battery Power	29562
• FB2250 Series SS, AC Power, No Bracket	29563
• FB2250 Series SS, AC/Battery Power, No Bracket	29564
• FB2250 Series SS, AC Power, No Bracket, IP69K	29013
• FB2250 Series SS, AC Power, IP69K	28990
• FB2250 Series, AC Power, Panel Mount	29803

1.2. Main Product Features

Major features of the Instrument include the following.

- Push-button programming and calibration.
- Program data is stored in battery supported RAM and backed up in flash memory.
- The battery should be replaced every 12 months.
- The FB2250 series instrument features a large one-inch high green backlit LCD weight display, which can be tilted up or down to accommodate different lighting conditions. Microprocessor controlled design allows the instrument to be rapidly programmed at installation to meet the specific requirements of the application.
- The obtainable accuracy meets Handbook 44 requirements, and the instrument is approved for commercial application up to 10,000 divisions. A maximum of 100,000 displayed divisions can be programmed for non-commercial applications.
- A computer utility software program PC2250 is available, via download from Fairbanks Intranet for programming via computer, and is required for certain features such as custom ticket formatting.

1.2. Main Product Features, Continued

- The PC2250 software utility program can also upload and modify the instruments set-up, configuration, and calibration. Saved information can be downloaded from a computer to the FB2250 Series in the event of a catastrophic failure.
- The instrument provides two (2) serial communication ports to provide communication to various types of peripheral devices for RS232, RS422, RS485, and 20mA data outputs.
- Optional accessories include a 4-20mA analog output, Bluetooth® serial adapter, and five different fieldbus devices; PROFIBUS®, DeviceNet™, ControlNet™, Modbus® and ETHERNET/IP.

1.3. Specifications

1.3.1. Instrument Approvals

• CC	09-023
• MC	AM-5720
• ETL	ETL Listed
• Conforms to ANSI/UL STD 60950-1	
• Certified to CAN/CSA C22.2 STD NO. 60950-1-03	

1.3.2. Specifications

• ENCLOSURE	ABS, Black NEMA 1, Stainless Steel NEMA 4X Desk and Wall Mount
• DISPLAY	6 digits, 1 inch LCD, Green Backlight
• FRONT PANEL KEYS	On/Off, Units, Zero, B/G, Net, Tare and Print
• UNITS	lbs, oz, kg, g and lbs/oz, or custom
• GRADUATION SIZE	0.0001 to 50
• AD CONVERSION	66 per second
• LOAD CELL EXCITATION	5 Volts DC
• SENSITIVITY	1µv/d (microvolt/division)
• LOAD CELLS	Eight (8) 350 ohm or Sixteen (16) 1000 ohm
• DISPLAYED DIVISIONS	10,000d Commercial and 100,000d Non-Commercial
• CAPACITIES	Programmable to 999999

1.3. Specifications, Continued

1.3.3. Settings

• Zero Range	2 % or 100%
• Auto Zero Tracking	OFF, 0.5, 1 or 3 divisions
• Balance	OFF, 0.5, 1 or 3 divisions
• Filter	Slow, Cattle, Standard, and Fast
• Display Update Rate	0.2, 0.4, and 0.8 seconds

1.3.4. Weight Accumulator

• Capacity	Up to 99,999 accumulations , or 999,999 totaled weight units . – Printed or viewed
------------	---

1.3.5. Outputs

• PORT 1	Bidirectional Serial Port. Settings include OFF, RS232, RS422, and RS485 . RS232 has 30+ updates a second
• PORT 2	Port 2 is used to interface to the PC2250 program , OR to provide 20mA passive, RS232, RS422* , or RS485 .

*Port should be set to RS485. Note jumper and wiring connections listed in **Section 5:Serial Communication Wiring**.

1.3.6. AC Operation

The FB2250 is designed to operate from **80 to 260 volts AC, 50 to 60 Hertz** with **Auto Switching** capability.

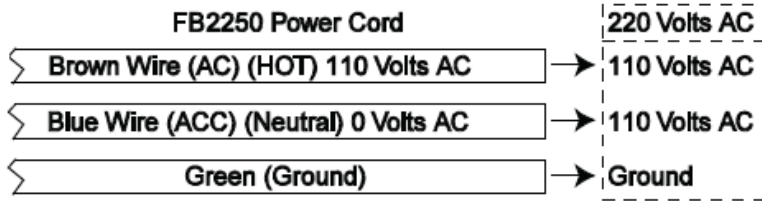
<ul style="list-style-type: none"> • 110 Volt AC Operation <ul style="list-style-type: none"> ○ The FB2250 is factory wired for 110 VAC and requires a three-prong grounded outlet. • 220 Volt AC Operation <ul style="list-style-type: none"> ○ Rewire the power cord according to the following diagram:
<p>FB2250 Power Cord</p> 
<ul style="list-style-type: none"> • 1.5 watts maximum • The FB2250 is designed to operate from 80 to 260 volts AC, 50 to 60 Hertz

1.3.7. DC Models

• Batteries	Five (5) Size "D" Alkaline batteries @ 1.5 Volts DC each.
• Battery Life	<p>Battery usage time can be adversely affected by battery storage, battery capacity and battery brand.</p> <p>To maximize battery life, serial Ports 1 and 2 should be switched OFF, if not used.</p> <p>(1) 350Ω load cell, Back Light = OFF, RS232 ports = OFF.....55 hours</p> <p>(4) 350Ω load cell, Back Light = ON, RS232 ports = OFF.....16 hours</p> <p>(4) 350Ω load cell, Back Light = OFF, RS232 ports = OFF.....33 hours</p>
• Internal Battery	• Should be replaced every 12 months using Panasonic CR 1220 3V or equivalent.

1.3.8. Out of Range Warnings

• HiCAP	Scale input is over capacity
• -----	Displayed weight exceeds 6 digits
• Sleep Mode	Settings include OFF, 1, 2, 5, 10, 20, and 30 minutes
• Time and Date	Battery Maintained

1.3.9. External Printers

• Tape Printers – Citizens IDP 3550 and Epson Model TM-U220 Tape Printers
• Serial Form Printers – Okidata 184 & 186 Serial Form Printer
Okidata 420 Serial Form Printer
• Ticket Printers – Epson Models TM-U295, TM-U590 Ticket Printers

1.3.10.Environment

• Temperature	-10°C to + 40°C (+14°F to + 104°F)
• Storage Temp.	-40°C to + 60°C (-40°F to + 140°F)

1.3.11.PC2250

<ul style="list-style-type: none"> • Computer software utility program is available for download using the Fairbanks Intranet. • PC2250 is required for setting certain aspects of programming, such as custom Units and custom ticket formatting.
--

1.3. Accessories

Optional accessories include the following.

FIELDBUS DEVICES				
• DeviceNet™	• ControlNet™	• PROFIBUS®-DP	• Modbus®	• ETHERNET/IP

4-20MA ANALOG CURRENT LOOP OUTPUT	
• 16 bit Resolution and Monotonicity	• 0.01% Non-Linearity
• Isolated 4mA to 20mA	• Front Panel Programmable or via PC2250 utility software program

BLUETOOTH® TECHNOLOGY INTERFACE
<ul style="list-style-type: none"> Utilizes either Port 1 or Port 2 Serial Output. RS232 serial Interface to Bluetooth Interface. Range 100 meters (328 feet). The Bluetooth option will operate either as a Client or Server depending on which device the FB2250 is connected. <ul style="list-style-type: none"> If connected to a printer, the FB2250 will be a Server. If connected to a PC, the Instrument will be a Client.

1.4. Battery Installation

STAINLESS STEEL ENCLOSURE

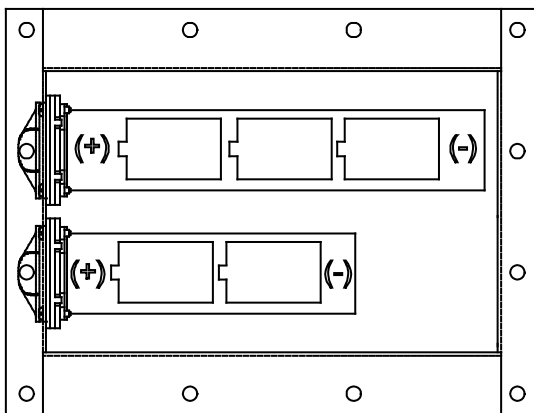

ABS ENCLOSURE

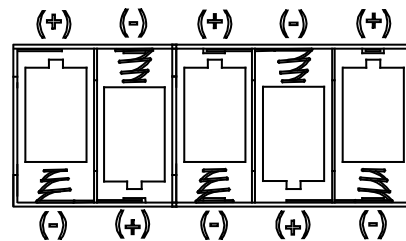

Stainless Steel Instrument: Unscrew the black plastic end caps and insert 5 alkaline “D” cells as shown above.

ABS Instrument: Unscrew the two large knurled screws on the back of the Instrument and remove the battery cover. Insert 5 alkaline “D” cells as shown above. Industrial "D" Size battery Energizer EN95 or equivalent is recommended for maximum operating time.

1.5. Powering up the FB2250

Press the ON / OFF Key for 1 to 2 seconds. The Instrument will display “888888” followed by a “1234567890” character display moving from right to left, followed by the revision of software. Upon completing the warm-up, the FB2250 will display the actual weight on the scale.

To turn the FB2250 off, press the **ON / OFF** key for 1 to 2 seconds.

1.6. Flow Charts

Dashed line boxes used in the flowchart indicate that the menu item availability is dependent upon programming performed elsewhere. For example, “clearing the accumulator” will not be available if accumulation has not been enabled.

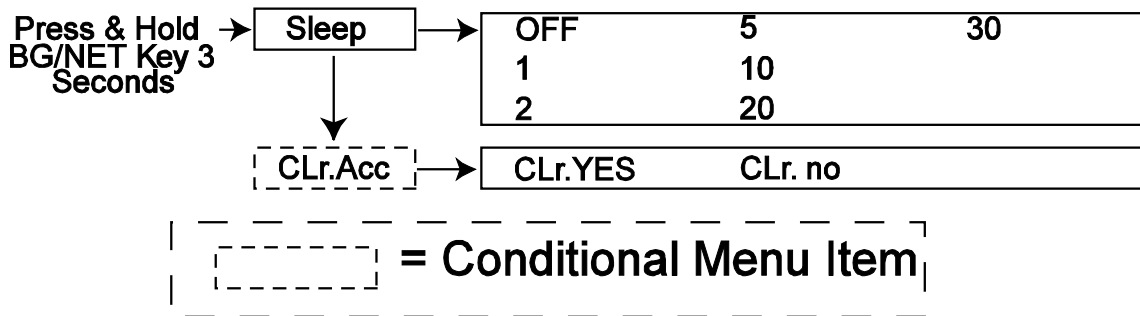

SECTION 2: FRONT PANEL PROGRAMMING

2.1. Front Panel Programming Parameters

Front Panel Programming

Operating ZERO enters the change Mode
 Operating UNITS scrolls through the selections
 Operating ZERO saves the change
 Operating B/G NET backs up through selections

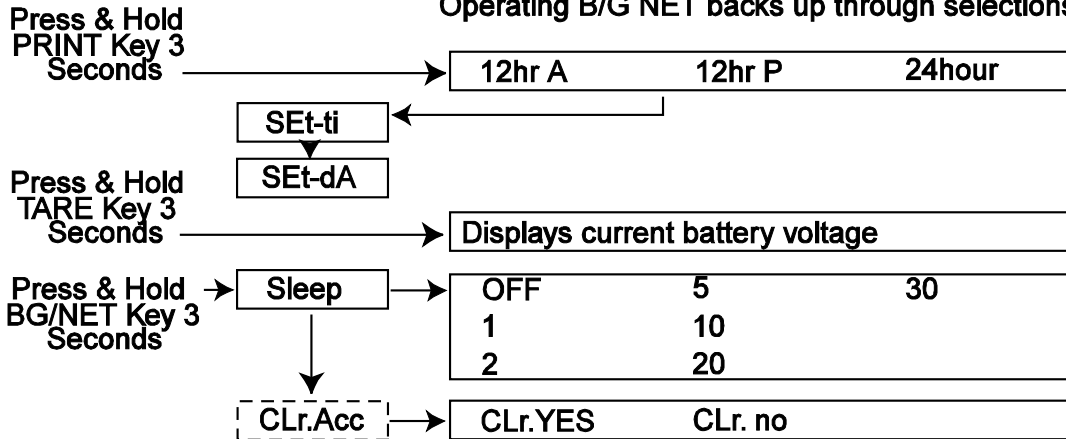

NOTE Press Zero key will Clear the Accumulator/Total Register/ Peak Weight parameters and set the Instrument to the Net/Gross Mode

NOTE Press Units key will not Clear the Accumulator/Total Register/ Peak Weight parameters and set the Instrument to the Net/Gross Mode

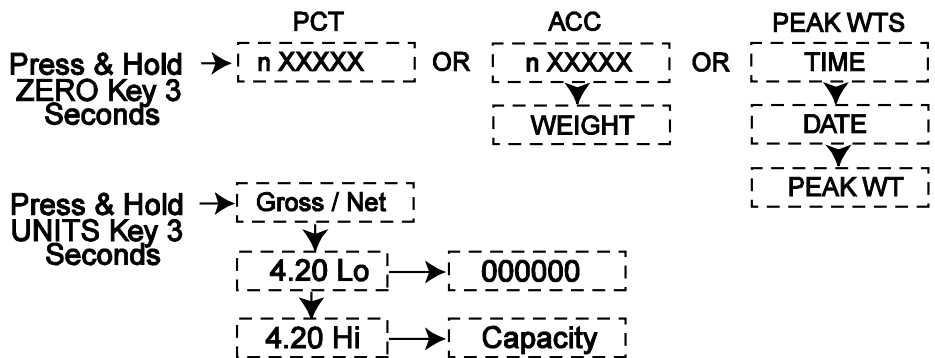

2.2. Front Panel Programming

2.2.1. Programming and Setting Time

1. Press and hold the **PRINT** key for three (3) seconds.
2. Current Time Format will display:
 - **12hr A** – 12 hour clock, currently AM.
 - **12hr P** – 12 hour clock, currently PM.
 - **24 hour** – Military time, (1:00 PM = 1300 hours).
3. Press the **ZERO** key to edit or **UNITS** key to skip.
 - Press the **UNITS** key to toggle through the available selections.
 - Press the **ZERO** key to enter the selection.
4. The display indicates **Set-ti**, and then shows the current time in **HHMMSS** format.
5. Press the **ZERO** key to edit or **UNITS** key to skip.
 - The Hour digits will blink.
 - Press **UNITS** key to increment to the **hour setting**.
 - Press **ZERO** key.
 - The Minutes digits will blink.
 - Press **UNITS** key to increment to the **minutes setting**.
 - Press **ZERO**.
 - The Seconds digits will blink.
 - Press **UNITS** to increment to the **seconds setting**.
 - Press **ZERO** to enter the time settings.
6. When complete, Program will advance to programming the date.

2.2.2. Programming the Date

1. **Set-dA** displays, followed by the current date setting in **MM-DD-YY** format.
2. Press the **ZERO** key to edit or **UNITS** key to skip.
 - The Month digits will blink.
 - Press **UNITS** key to increment to the desired month setting.
 - Press the **ZERO** key to advance to the day setting.
 - The Day digits will blink.
 - Press **UNITS** key to increment to the desired day setting.
 - Press the **ZERO** key to advance to the year setting.
 - The Year digits will blink.
 - Press **UNITS** key to increment to the desired year setting.
 - Press the **ZERO** key to save the date setting.
3. When complete, the FB2250 will return to the weight mode.

2.2.3. Display Battery Voltage

1. Press and hold the **TARE** key for three (3) seconds.
 - The battery current or power supply voltage displays
 - **8.3 VDC nominal**
2. When **TARE** key is released, the FB2250 will return to the weight mode.

2.2.4. Programming the Sleep Function

This function serves to prolong battery life by turning off the Instrument. When there is no activity, the **Sleep Mode** activates according to the programmed time frame. Activity is when weight is applied to the scale exceeding the motion band setting, pressing a key, or receiving a polling request on a communication port.

1. Press and hold the **BG/Net** key for three (3) seconds.
2. The display will indicate **SLEEP**, and then display the current setting.
 - Settings in minutest include **OFF, 1, 2, 5, 10, 20, 30.**
3. Press the **ZERO** key to edit or **UNITS** key to skip.
 - Press **UNITS** key to scroll through available settings.
 - Press **ZERO** key to enter the selection.
4. When complete, the FB2250 will return to the weight mode, if the Accumulator function is not active.

2.2.5. Clearing the Accumulator

The Accumulator(s) to be cleared depend on whether the **Operating Mode** is programmed to **Accumulation** or **Piece Count and Total**. (See Section 3.5 [Operating Mode](#) for details)

- Press and hold the **BG/Net** key for three (3) seconds.
 - Press **UNITS** key until **CLr.ACC** displays on the Instrument.
1. Press the **ZERO** key to edit or **UNITS** key to skip.
 - Press **UNITS** key to toggle the available settings.
 - **CLr.YES** (Clear the Accumulator)
 - **CLr.NO** (Do NOT Clear the Accumulator)
 - Press the **ZERO** key to enter the selection.
 2. When complete, the FB2250 will return to the weight mode.

2.2.6. Display Operating Mode Data

NOTE: These options are conditional upon programming the **Operating Mode** (See Section 3.5 [Operating Mode](#) for details)

1. Press and hold the **ZERO** key for three (3) seconds.
2. Depending upon how the FB2250 was programmed in the **Operating Mode**, one of these conditions will occur:
 - **ACCUMULATION:**
 - The display will alternate between the number of Gross weight Accumulations "**n**" and the total Gross weight Accumulated for thirty (30) seconds, and then return to the **Weigh Mode**.
 - The caret (v) above the printed *Total Weight Accumulated* legend of the display will be seen.
 - Press the **B/G NET** key
 - The display will alternate between the number of Net weight Accumulations "**n**" and the total Net weight Accumulated for thirty (30) seconds, and then return to the **Weigh Mode**.
 - The caret (v) above the printed *Total Weight Accumulated* and *NET* legends of the display will be seen.
 - **PIECE COUNT** or **PIECE COUNT AND TOTAL:**
 - After completing an initial piece sampling
 - When in the NET Weigh Mode (with container), the number of pieces "**n**" on the scale at the time the key is pressed will be displayed for 30 seconds.
 - When in the Gross Weigh Mode (without container), the number of pieces "**n**" on the scale at the time the key is pressed will be displayed for 30 seconds.
 - **PEAK HOLD STABLE** or **PEAK HOLD UNSTABLE;** displays time, date, and peak weight, then times out to the Weigh Mode in thirty (30) seconds.
3. Pressing the **UNITS** key will skip time out and immediately exit to the Weigh Mode.

2.2.7. 4-20mA Output Setup

WARNING: Do not physically install the 4-20mA card until the instrument is configured and calibrated (weight) to the platform.

The 4-20mA analog output is passive, therefore it requires the receiving element to supply the loop with a dedicated, isolated power source from 7-24V DC. The output is linear throughout the range from 4mA to 20mA and can be programmed to increase (upweigh) or decrease (downweigh) as weight is increased.

Connections are as follows:

Pin 1	+ 4-20mA
Pin 2	- 4-20mA

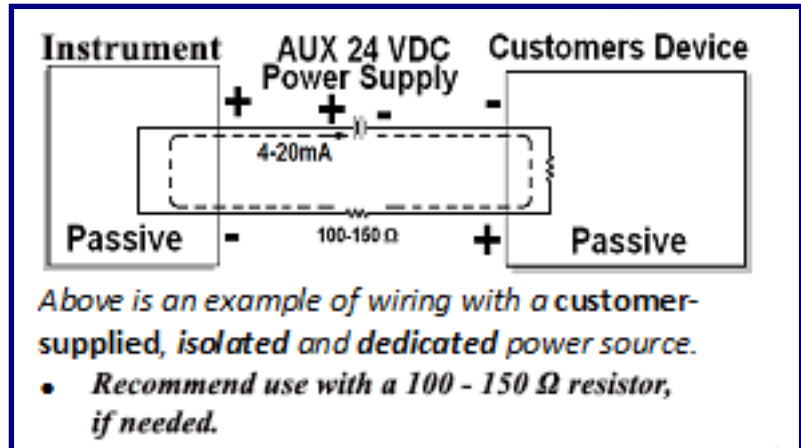
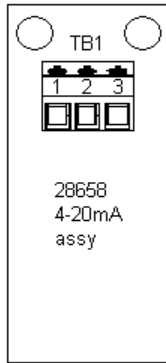

2.2.8. Programming the 4-20mA Analog Output Weighing Mode

Setting up the **4-20mA Option** depends on how it is enabled and configured.

1. Press and hold **UNITS** for three (3) seconds.
2. **4-20** displays, followed by the current setting
 - **GROSS** or **NET**.
 - The 4-20mA analog output will track the selection.
 - It will continue to track the selection regardless of the active weight display mode of the FB2250.
3. Press the **ZERO** key to edit or the **UNITS** key to skip.
 - Press the **UNITS** key to toggle the available settings.
 - Press **ZERO** to enter the selection.

When complete, Program will advance to programming the 4-20mA 4mA setting.

2.2.9. Programming the 4mA Weight Value

1. **4.20 Lo** displays, followed by the current setting.
2. If the output needs fine-tuned, use the **TARE** or **PRINT** keys to adjust. **Adj Lo** displays.
3. Press **ZERO** to return to the weight settings.
4. Press the **ZERO** to edit or press the **UNITS** key to skip.

- a. The most significant digit will be blinking, operate the **UNITS** key to increment the number.
- b. When the desired value has been obtained, Press the **ZERO** key.
- c. The next less significant digit will then blink, operate the **UNITS** key to increment the number.
- d. Repeat steps b and c until the least significant digit has been completed.

*This weight value will result in a **4mA Output**.*

5. When complete, the program will advance to the 20mA menu.

2.2.10. Programming the 20mA Weight Value

1. **4.20 Hi** displays, followed by the current setting.
2. If the output needs fine-tuned, use the **TARE** or **PRINT** keys to adjust. **Adj Hi** displays.
3. Press **ZERO** to return to the weight settings.
4. Press the **ZERO** key to edit or press the **UNITS** key to skip.
 - a. The most significant digit will be blinking, operate the **UNITS** key to increment the number.
 - b. When the desired value has been obtained, Press the **ZERO** key.
 - c. The next less significant digit will then blink, operate the **UNITS** key to increment the number.
 - d. Repeat steps b and c until the least significant digit has been completed.

*This weight value will result in a **20mA Output***

5. When complete, the FB2250 will return to weigh mode.

NOTE: Fine tune adjustment is available in firmware version 2.04 and after.

SECTION 3: OPERATION

3.1. Setup Menu Programming Parameters – Version 2.0+

Set-up Menu Version 2.0 +

Operating ZERO enters the change Mode
 Operating UNITS scrolls through the selections
 Operating ZERO saves the change
 Operating B/G NET backs up through selections

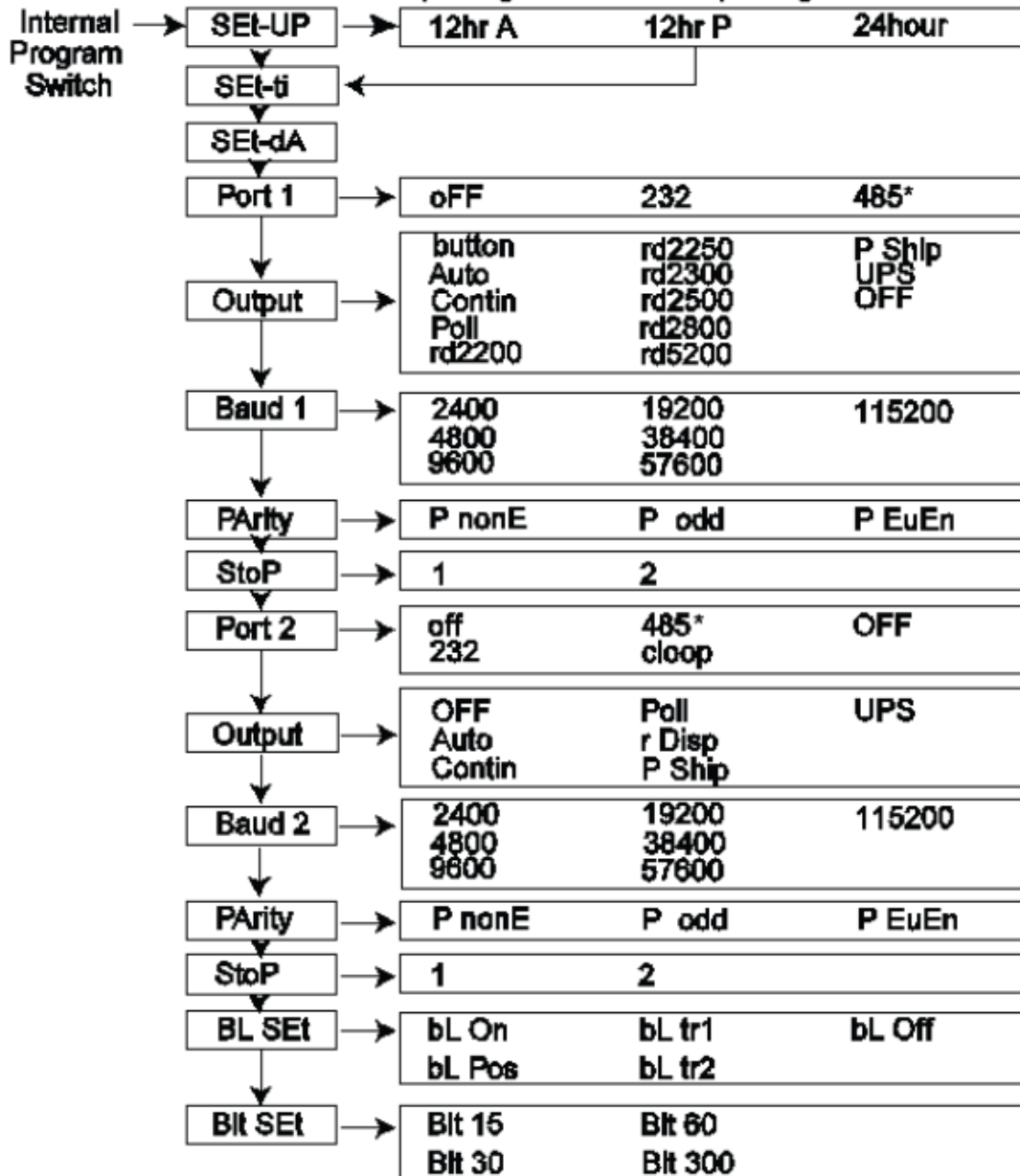

* RS485 is selected when RS422 output is required. Reference wiring and jumper connections in **Section 5: Serial Communication Wiring**.

3.2. Setup Menu Programming

1. Press the **INTERNAL PROGRAM SWITCH** until **Setup** displays.
2. Press the **UNITS** key.

3.2.1. Programming and Setting Time

1. The current display format setting will display
 - **12hr A** – 12 hour clock, currently AM.
 - **12hr P** – 12 hour clock, currently PM.
 - **24 hour** – Military time (1:00 PM = 1300 hours).
2. Press the **ZERO** key to edit or **UNITS** key to skip.
 - Press the **UNITS** key to toggle through the available selections.
 - Press the **ZERO** key to save the selection.
3. **Set-ti** displays, followed by the current time setting in **HHMMSS** format.
4. Press the **ZERO** key to edit or **UNITS** key to skip.
 - The Hour digits will blink.
 - Press **UNITS** key to increment to the **hour setting**.
 - Press **ZERO** key.
 - The Minutes digits will blink.
 - Press **UNITS** key to increment to the **minutes setting**.
 - Press **ZERO**.
 - The Seconds digits will blink.
 - Press **UNITS** to increment to the **seconds setting**.
 - Press **ZERO** to enter the time settings.
5. When complete, the program will advance to Programming the Date.

3.2.2. Programming the Date

1. **Set-dA** displays, followed by the current date setting in **MM-DD-YY** format.
2. Press the **ZERO** key to edit or **UNITS** key to skip.
 - The Month digits will blink.
 - Press **UNITS** key to increment to the desired month setting.
 - Press the **ZERO** key to advance to the day setting.
 - The Day digits will blink.
 - Press **UNITS** key to increment to the desired day setting.
 - Press the **ZERO** key to advance to the year setting.
 - The Year digits will blink.
 - Press **UNITS** key to increment to the desired year setting.
 - Press the **ZERO** key to save the date setting.
3. When complete, the program will advance to Port 1.

3.2.3. Programming Port 1

1. **Port 1** displays, followed by the current protocol setting.
 - OFF – com port is not active.
 - rS232 – using RS232 protocol
 - rS485 – using RS485 or RS422 protocol
2. Press **ZERO** key to edit, or **UNITS** key to skip.
 - Press the **UNITS** key to scroll through available settings.
 - Press **ZERO** to select an option.
3. When complete, the program will advance to Port 1 output.

NOTE: See [Section 5.2. TB4 Connections, COM1 \(A\), COM2 \(B\), and COM2 \(C\)](#)

3.2.4. Programming the Port 1 Output Type

1. **Output** displays, followed by the current output type setting:
 - **Button** -Using the Print key.
 - **Auto**- Activated by stable weight above 10d, reset by return to half of printed weight.
 - **Contin** -Continuous Output. Once every display update rate.
 - **Poll** -Demand Output by receipt of CR or programmed poll character
 - **Rd2200** -Remote Display for FB2200
 - **Rd2250** -Remote Display for FB2250/55
 - **Rd2300** -Remote Display for 2300
 - **Rd2500** -Remote Display for 2500
 - **Rd2800** -Remote Display for 2800
 - **Rd5200** -Remote Display for 5200
 - **P Ship** -Used for FedEx Shipping Software
 - **UPS** -Used for UPS Shipping Software
 - **OFF** -Output is not active
2. Press **ZERO** key to edit, or **UNITS** key to skip.
 - Press the **UNITS** key to scroll through available settings.
 - Press **ZERO** to select an option.
3. When complete, the program will advance to Port 1 Baud Rate.

3.2.5. Programming Port 1 Baud Rate

1. **Baud 1** displays, followed by the current baud rate setting.
 - 2400
 - 4800
 - 9600
 - 19200
 - 38400
 - 57600
 - 115200
2. Press **ZERO** key to edit, or **UNITS** key to skip.
 - Press the **UNITS** key to scroll through available settings.
 - Press **ZERO** key to select an option.
3. When complete, the program will advance to Port 1 Data Bits.

3.2.6. Programming Port 1 Data Bits

1. **d-bitS** displays, followed by the current data bits setting:
 - 8
 - 7
2. Press **ZERO** key to edit, or **UNITS** key to skip.
 - Press the **UNITS** key to scroll through available settings.
 - Press **ZERO** key to select an option.
3. When complete, the program will advance to Port 1 Parity Setting.

3.2.7. Programming Port 1 Parity Setting

1. **Parity** displays, followed by the current parity bit setting:
 - **P None** – no parity bit
 - **P Odd** - odd parity bit
 - **P Even** – even parity bit
2. Press **ZERO** key to edit, or **UNITS** key to skip.
 - Press the **UNITS** key to scroll through available settings.
 - Press **ZERO** key to select an option.
3. When complete, the program will advance to Port 1 stop bits.

3.2.8. Programming Port 1 Stop Bits

1. **Stop** displays, followed by the current stop bits setting:
 - 1
 - 2
2. Press **ZERO** key to edit, or **UNITS** key to skip.
 - Press the **UNITS** key to scroll through available settings.
 - Press **ZERO** key to select an option.
3. When complete, the program will advance to Port 2.

3.2.9. Programming Port 2

1. **Port 2** displays, followed by the current protocol setting:
 - **OFF** – com port is not active
 - **rS232** - Using RS232 protocol
 - **rS485** - Using RS485 or RS422 protocol
 - **Cloop** Using 20mA Current Loop (passive)
2. Press **ZERO** key to edit, or **UNITS** key to skip.
 - Press the **UNITS** key to scroll through available settings.
 - Press **ZERO** key to select an option.
3. When complete, the program will advance to Port 2 Output.

3.2.10. Programming the Port 2 Output Type

1. **Output** displays, followed by the current output type setting:
 - **Auto** - Activated by stable weight above 10d, reset by return to half of printed weight.
 - **Contin** - Continuous Output. Once every display update rate.
 - **Poll** - Demand Output by receipt of CR from external source.
 - **r Disp** – 1600 Series Remote Display output format
 - **P Ship** - Used for Fed Ex Shipping Software
 - **UPS** - Used for UPS Shipping Software
 - **OFF** - output is not active.
2. Press **ZERO** key to edit, or **UNITS** key to skip.
 - Press the **UNITS** key to scroll through available settings.
 - Press **ZERO** key to select an option.
3. When complete, the program will advance to Port 2 baud rate.

3.2.11. Programming Port 2 Baud Rate

1. **Baud 2** displays, followed by the current baud rate setting.
 - 2400
 - 4800
 - 9600
 - 19200
 - 38400
 - 57600
 - 115200
2. Press **ZERO** key to edit, or **UNITS** key to skip.
 - Press the **UNITS** key to scroll through available settings.
 - Press **ZERO** key to select an option.
3. When complete, the program will advance to Port 2 Data Bits.

3.2.12. Programming Port 2 Data Bits

1. **d-bitS** displays, followed by the current data bits setting:
 - 8
 - 7
2. Press **ZERO** key to edit, or **UNITS** key to skip.
 - Press the **UNITS** key to scroll through available settings.
 - Press **ZERO** key to select an option.
3. When complete, the program will advance to Port 2 Parity Setting.

3.2.13. Programming Port 2 Parity Setting

1. **Parity** displays, followed by the current parity bit setting:
 - **P None** – no parity bit
 - **P Odd** - odd parity bit
 - **P Even** – even parity bit
2. Press **ZERO** key to edit, or **UNITS** key to skip.
 - Press the **UNITS** key to scroll through available settings.
 - Press **ZERO** key to select an option.
3. When complete, the program will advance to Port 2 stop bits.

3.2.14. Programming Port 2 Stop Bits

1. **Stop** displays, followed by the current stop bits setting:
 - 1
 - 2
2. Press **ZERO** key to edit, or **UNITS** key to skip.
 - Press the **UNITS** key to scroll through available settings.
 - Press **ZERO** key to select an option.
3. When complete, the program will advance to Back light options.

3.2.15. Programming the Back Light Options

1. The current setting displays:
 - **bL On** - Back light always **ON**.
 - **bL POS** - Back light only on with a positive weight on the scale, otherwise off.
 - **bL tr1** - Back light **ON** with a positive weight on the scale until weight has been stable for the amount of time selected at the following program step.
 - **bL tr2** - Back light **ON** with a positive weight until returned to zero and stable for the amount of time selected at the following program step.
 - **bL OFF** - Back light always **OFF**.
2. Press **ZERO** key to edit, or **UNITS** key to skip.
 - Press the **UNITS** key to scroll through available settings.
 - Press **ZERO** key to select an option.
3. When complete, the program will advance to Back light timing.

3.2.16. Programming the Back Light Timing

1. The current setting displays:
 - **bLt 15** - back light remains illuminated 15 seconds
 - **bLt 30** - back light remains illuminated 30 seconds
 - **bLt 60** - back light remains illuminated 60 seconds
 - **bLt 300** - back light remains illuminated 300 seconds
2. Press **ZERO** key to edit, or **UNITS** key to skip.
 - Press the **UNITS** key to scroll through available settings.
 - Press **ZERO** key to select an option.
3. When complete, the program will advance to Configuration Menu.

3.3. Configuration Menu Programming Parameters

ConFig Menu

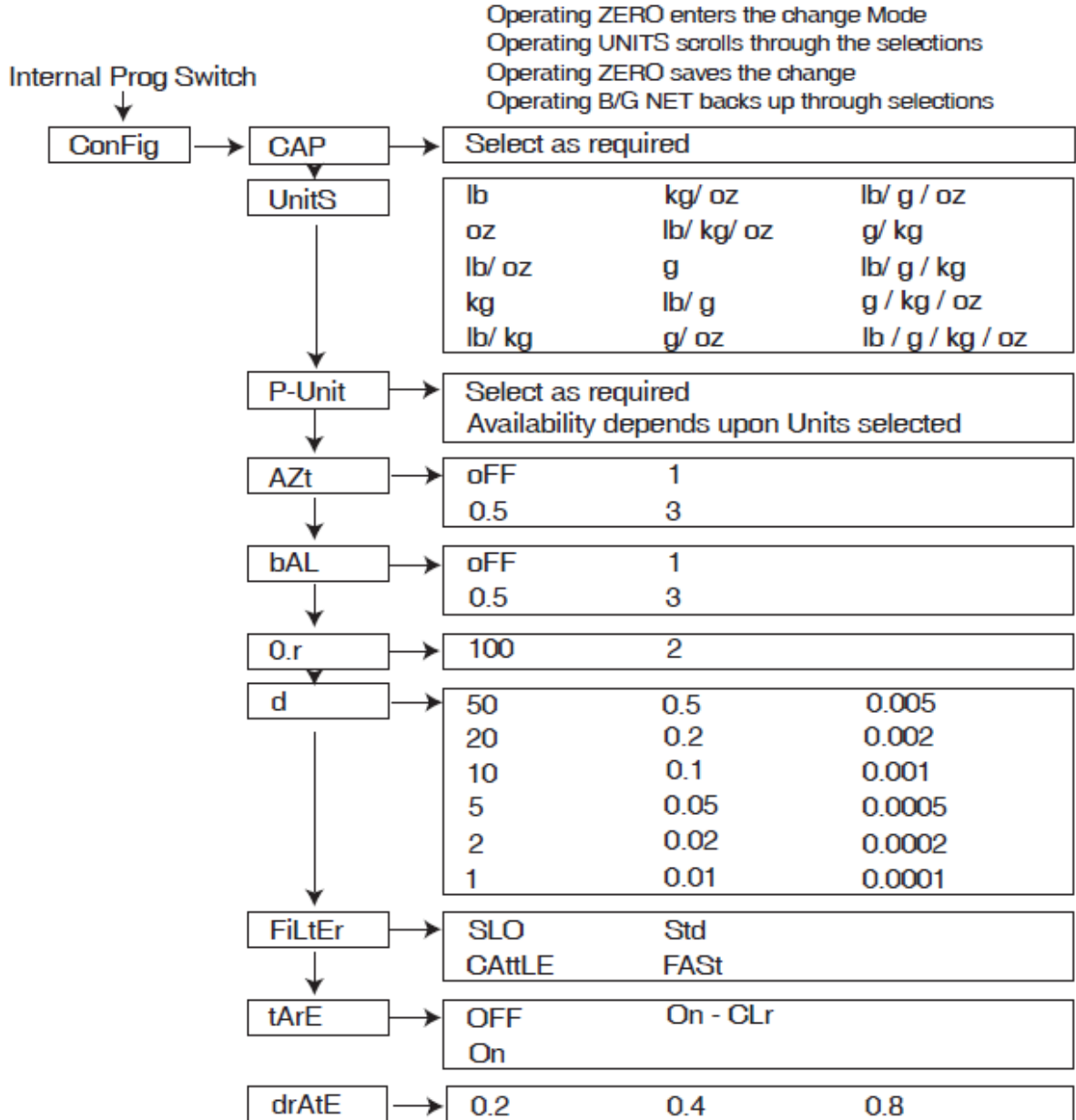

3.3. Configuration Menu Programming Parameters, Continued

1. Press the **INTERNAL PROGRAM SWITCH** until **ConFig** is displayed.
2. Press the **UNITS** key.

3.3.1. Programming the Scale Capacity

1. **CAP** displays, followed by the current scale capacity setting with a caret symbol (V) located above the printed unit legend of the display representing the current primary unit setting.
2. Press **ZERO** key to edit, or **UNITS** key to skip.
 - Most significant digit will blink
 - Press **UNITS** key to scroll through available settings.
 - Press **ZERO** key to enter and advance to next digit
 - Repeat the process until the least significant digit is selected.
3. When complete, the program will advance to scale units.

NOTE: Capacity can be up to six (6) displayed digits (i.e. 999999). All six digits must be entered to advance to the next parameter.

3.3.2. Programming the Scale Units

1. **UnitS** displays, and the current setting with a caret symbol (V) above the printed unit(s) legend of the display.
2. Press **ZERO** key to edit, or **UNITS** key to skip.
 - Press the **UNITS** key to scroll through available settings.
 - The caret will automatically move to the choices.
 - Available selections include any single or combinations of:
 - lb - pounds
 - kg - kilograms
 - oz - ounces
 - g - grams
 - Press **ZERO** key to save the selection.
3. When complete, the program will advance to programming primary unit.

NOTES:

1. **lb-oz** and **custom** units are also available but can only be programmed with the PC2250 software utility (see [Section 7](#).)
2. The **lb-oz** and **custom unit** settings cannot be used as the **Primary Unit** in the FB2255. **They are not legal for trade.**
3. When using **lb-oz**, the FB2250 must be calibrated in **lb** or **oz**, and not **lb-oz**.

4. When programming for **lb-oz**, the division size must be 0.2 or smaller; 0.5 or higher will not convert to lbs/oz, the instrument will display dashes.
 5. When **lb-oz** units are active, both the lb and oz caret symbols are on.
 6. When **custom** units are active, all caret symbols are off.
-

3.3.3. Programming the Primary Unit

This option sets up the **Unit** parameter for scale capacity, calibration, and the default unit when the instrument is powered up.

1. **P-Unit** displays, and the current Primary Unit setting with a caret symbol (v) above the printed unit legend of the display.
2. Press **ZERO** key to edit, or **UNITS** key to skip.
 - Press the **UNITS** key to scroll through available settings.
 - The caret will automatically move to the choices.
 - Available selections include:
 - lb - pounds
 - kg - kilograms
 - oz - ounces
 - g - grams
 - Press **ZERO** key to save the selection.
3. When complete, the program will advance to programming AZT.

3.3.4. Programming the Automatic Zero Tracking Band

This option maintains **ZERO** when small amounts of material are placed on the scale, such as rain, snow, debris, etc.

1. The current AZT setting displays:
 - **AZt .off** – function is not active.
 - **AZt 0.5** - Half of a division / increment / graduation
 - **AZt 1** - One division / increment / graduation
 - **AZt 3** - Three divisions / increments / graduations
2. Press **ZERO** key to edit, or **UNITS** key to skip.
 - Press the **UNITS** key to scroll through available settings.
 - Press **ZERO** key to select an option.
3. When complete, the program will advance to programming the Motion Band.

3.3.5. Programming the Motion Band

This option defines the range that weight must be stable before the scale can be zeroed and the print function can generate a ticket.

1. The current motion band setting displays:

- **bAL .off** – function is not active.
 - **bAL 0.5** - Half of a division / increment / graduation
 - **bAL 1** - One division / increment / graduation
 - **bAL 3** - Three divisions / increments / graduations
2. Press **ZERO** key to edit, or **UNITS** key to skip.
 - Press the **UNITS** key to scroll through available settings.
 - Press **ZERO** key to select an option.
 3. When complete, the program will advance to programming the Motion Band.

3.3.6. Programming the Zero Range

This option defines the percentage of scale capacity that can be “zeroed” off by pressing the **ZERO Key**.

1. The current zero range setting displays:
 - **O.r 100** - One hundred percent (100%) zero range
 - **O.r 2** - Two percent (2%) zero range
 - **Disabl** - Disables the **ZERO** key.
2. Press **ZERO** key to edit, or **UNITS** key to skip.
 - Press the **UNITS** key to scroll through available settings.
 - Press **ZERO** key to select an option.
3. When complete, the program will advance to programming the Division Size.

3.3.7. Programming the Division Size

1. The current division size setting displays:
 - **d X**, where **X** is one of the following:

• 50	• 20	• 10	• 5	• 2
• 1	• 0.5	• 0.2	• 0.1	• 0.05
• 0.02	• 0.01	• 0.005	• 0.002	• 0.001
• 0.0005	• 0.0002	• 0.0001		
2. Press **ZERO** key to edit, or **UNITS** key to skip.
 - Press the **UNITS** key to scroll through available settings.
 - Press **ZERO** key to select an option.
3. When complete, the program will advance to programming the Division Size.

3.3.8. Programming the Filter Setting

This option compensates for the effects of motion, vibration, and wind currents.

1. **FILtEr** displays, followed by the current filter setting:

- **SLO** - Heavy filtering
 - **Cattle** - Very heavy filtering
 - **Stand** - Medium filtering
 - **FASt** - Light filtering
2. Press **ZERO** key to edit, or **UNITS** key to skip.
 - Press the **UNITS** key to scroll through available settings.
 - Press **ZERO** key to select an option.
 3. When complete, the program will advance to programming the Tare setting.

3.3.9. Programming the Tare Setting

This option determines whether or not the instrument will display the product's **Net Weight**, without the container's weight.

1. **tArE** displays, followed by the current **Tare** setting:
 - **OFF** - Tare is disabled.
 - **ON** - Tare is active.
 - **On-CLr** - Tare automatically clears when Gross Weight returns to ZERO.
2. Press **ZERO** key to edit, or **UNITS** key to skip.
 - Press the **UNITS** key to scroll through available settings.
 - Press **ZERO** key to select an option.
3. When complete, the program will advance to programming the display update rate.

3.3.10. Programming the Display Update Rate

This option sets the allotted time between **Display Updates**.

1. **drAtE** displays, followed by the current update rate setting:
 - **0.2** - 200 milliseconds
 - **0.4** - 400 milliseconds
 - **0.8** - 800 milliseconds
2. Press **ZERO** key to edit, or **UNITS** key to skip.
 - Press the **UNITS** key to scroll through available settings.
 - Press **ZERO** key to select an option.
3. When complete, the program will advance to the Application Menu.

3.4. Application Menu Programming Parameters

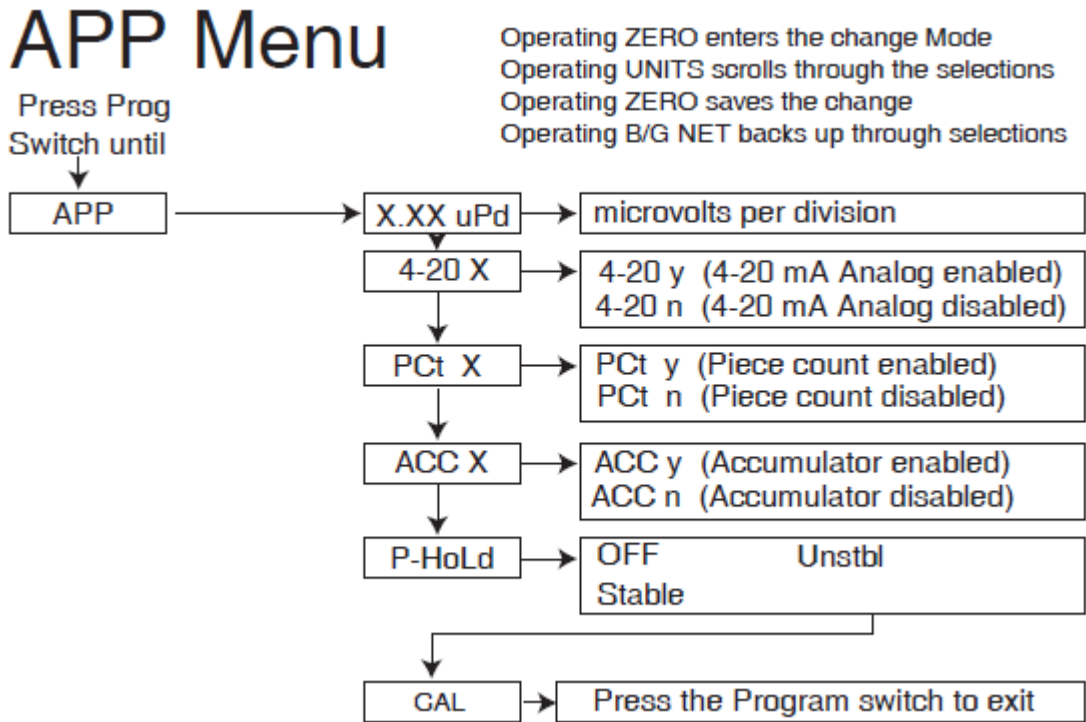

1. Press the **Internal Program Switch** until **APP** displays.
2. Press **UNITS** key.

3.4.1. Microvolts Per Division

X.XX uPd displays where X.XX is the current **microvolts per division** for the FB2250.

3.4.2. Programming the 4-20mA Analog Output

WARNING: Do not physically install the 4-20mA card until the instrument is configured and calibrated (weight) to the platform.

1. The current 4-20mA setting displays:
 - **4-20 n** – front panel access is disabled while the analog output continues to operate.
 - **4-20 Y** – front panel access is active while the analog output continues to operate.
2. Press the **UNITS** key to scroll through available settings. Press **ZERO** key to select an option.
3. When complete, the program will advance to programming piece count.
 - * See [Section 2](#) for Front Panel Programming details

3.4.3. Programming the Piece Count Feature

1. The current piece count setting displays:
 - **Pct n** – feature is disabled (NO)
 - **Pct Y** – feature is active (YES)
2. Press **ZERO** key to edit, or **UNITS** key to skip.
 - Press the **UNITS** key to scroll through available settings.
 - Press **ZERO** key to select an option.
3. When complete, the program will advance to programming the accumulator.

NOTE: See sections **3.5.11. – 3.5.14.** for user operations of this feature.

3.4.4. Programming the Accumulator Feature

1. The current accumulator setting displays:
 - **ACC n** – feature is disabled (NO)
 - **ACC Y** – feature is active (YES)
2. Press **ZERO** key to edit, or **UNITS** key to skip.
 - Press the **UNITS** key to scroll through available settings.
 - Press **ZERO** key to select an option.
3. When complete, the program will advance to programming the peak hold.

NOTE: See sections **3.5.8. – 3.5.10.** for user operations of this feature.

3.4.5. Programming the Peak Hold Feature

1. **P-Hold** displays, followed by the current peak hold setting:
 - **OFF** - feature is disabled.
 - **StAbLE** – peak hold when weight is stable
 - **UnStbL** – peak hold even when weight is unstable.
2. Press **ZERO** key to edit, or **UNITS** key to skip.
 - Press the **UNITS** key to scroll through available settings.
 - Press **ZERO** key to select an option.
3. When complete, the program will advance to the calibration menu.

NOTE: See section **3.5.16.** for user operation of this feature.

3.5. Operating Mode

Operating Mode

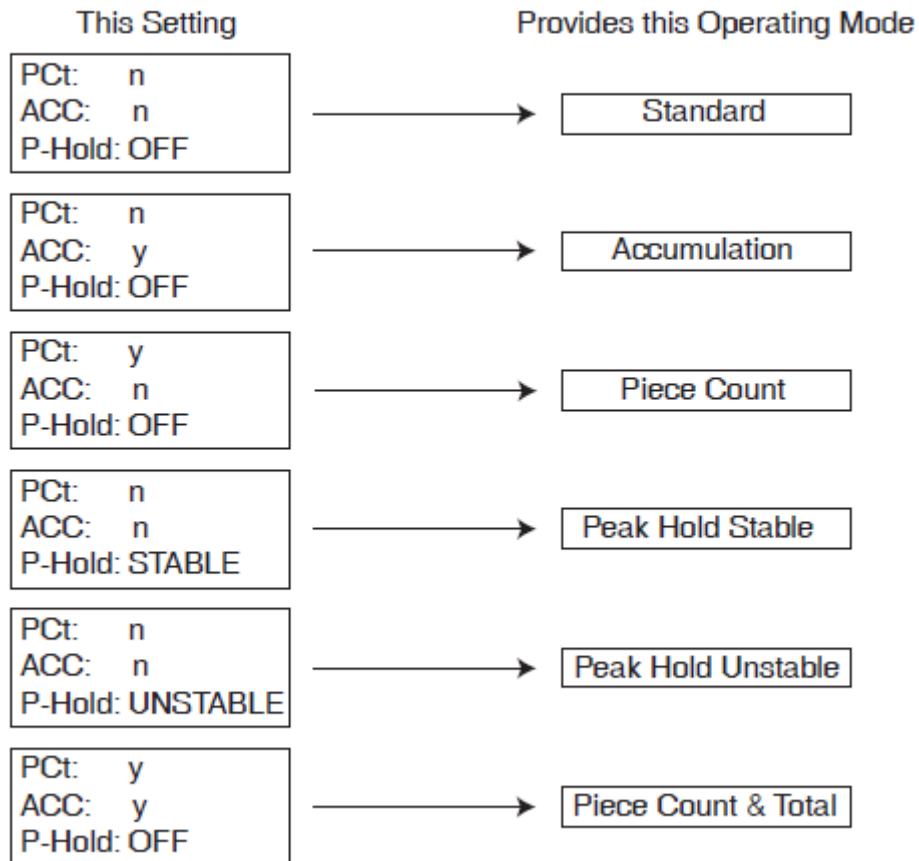

NOTE: See [Section 3.5. Operating Mode](#).

3.5.1. Front Panel Key Functions

- ON/OFF** Turns the Instrument on or off.
- UNITS** Switches between pre-programmed selectable weight units.
- ZERO** Sets the display to zero, programmable: 2% or 100% of capacity.
- B/G – NET** Toggles between Gross and Net weights
(only if a tare value has been entered greater than zero)

TARE automatically tares off displayed weight when key is pressed.

Depending on programmed selection, Tare weight will either:

- A. Be retained for reuse until changed or power is removed,
- or
- B. Automatically clear when Gross weight returns to Zero.

PRINT Simple RS232 output when key is pressed.



3.5.2. Operating Procedures

Press the **ON / OFF** Key for one to two (1 – 2) seconds. The Instrument will display “888888” followed by a “1234567890” character display moving from right to left, followed by the revision of software. Upon completing the warm-up, the FB2250 will either display zero, or it will display the actual weight on the scale.

The Zero function, Tare function, and AZT require the displayed weight to be stable before these functions will operate. The weight reading is stable if the variation in weight is less than the programmed bAL range.

3.5.3. Instrument Weighing Functions

The industry uses three terms to describe the apportionment of an object's weight. These terms are GROSS WEIGHT, TARE WEIGHT, and NET WEIGHT.

Example: A can of house paint is an object to be weighed. The empty can is the 'TARE' weight, the paint is the 'NET' weight, and together they equal the 'GROSS' weight.

$$\begin{aligned} \text{GROSS} &= \text{NET} + \text{TARE} \\ \text{GROSS} - \text{NET} &= \text{TARE} \\ \text{GROSS} - \text{TARE} &= \text{NET} \end{aligned}$$

3.5.4. Basic Weighing

Ensure platform is empty, turn the scale ON, press the ZERO key and the display indicates "0" and is ready for use.

3.5.5. Gross Weighing

Follow these steps for Gross Weighing.

1. Unload the Scale.
2. Press the **ZERO** key, if required, to set scale to "0".
3. Place container/object on scale.
4. Read the **Gross Weight** on the display.

3.5.6. Net Weighing

Follow these steps for Net Weighing:

1. Unload the Scale.
2. Press the **ZERO** key, if required, to set scale to "0".
3. Place container/object on scale (Tare weight).
4. Press the **TARE** key.
5. Place material in container or add objects (Net weight).
6. Read the **Net Weight** on the display. The caret (v) above the printed NET legend of the display will be seen.
7. To Exit; unload the scale and press the **TARE** key.

3.5.7. Gross/Tare/Net Weighing

1. Unload the Scale.
2. Press the **ZERO** key, if required, to set scale to “0”.
3. Place container/object on scale.
4. Press **TARE** key.
5. Place material in container or add objects.
6. Note the **Net Weight** on the display. The caret (v) above the printed NET legend of the display will be seen.
7. Press the **GROSS/NET** key to switch to read the **Gross Weight** on the display.
8. Press the **GROSS/NET** key to toggle back and forth between **Gross** and **Net** weight.
9. To Exit; unload the scale and press the **TARE** key.

3.6. Weight Accumulation

Note: For the following operations to function:

- The Accumulator parameter “ACC” must be set to “Y” (See [Section 3.7.4: Programming the Accumulator Feature](#))
 - When using PC2250 utility program, Operating Mode must be set to “Accumulation” (See [Section 8.6: Configuration](#)).
-

3.6.1. Weight Accumulation

1. Unload the Scale.
2. Press the **ZERO** key, if required, to set scale to “0”.
3. (optional) If the weighment is going to require a Tare, place the object or container on the scale and press the **TARE** key.
4. Place material on the scale.
5. When the weight is stable, press the **B/G NET** key. The display alternates between the number of Accumulations “n” and the total weight Accumulated, either NET or Gross.
 - The caret will appear above *Total Weight Accumulated*. A caret will also appear above NET if a tare was entered.
6. Press the **UNITS** key to accept the weight, display will momentarily indicate “**ACCEPT**”, and return to the weigh screen.

OR

Press the **B/G NET** key to skip and return to the weigh screen.

7. The scale must return to “0” **Gross Mode** before another accumulation can occur.
8. Repeat steps 3 through 7 for additional accumulations, up to 99,999 accumulations, or 999,999 totaled weight units.

NOTE: Gross and Net accumulations are stored and reported separately in the 2250, and the status of each weighment is determined by whether a Tare was initially entered.

3.6.2. Printing Weight Accumulations

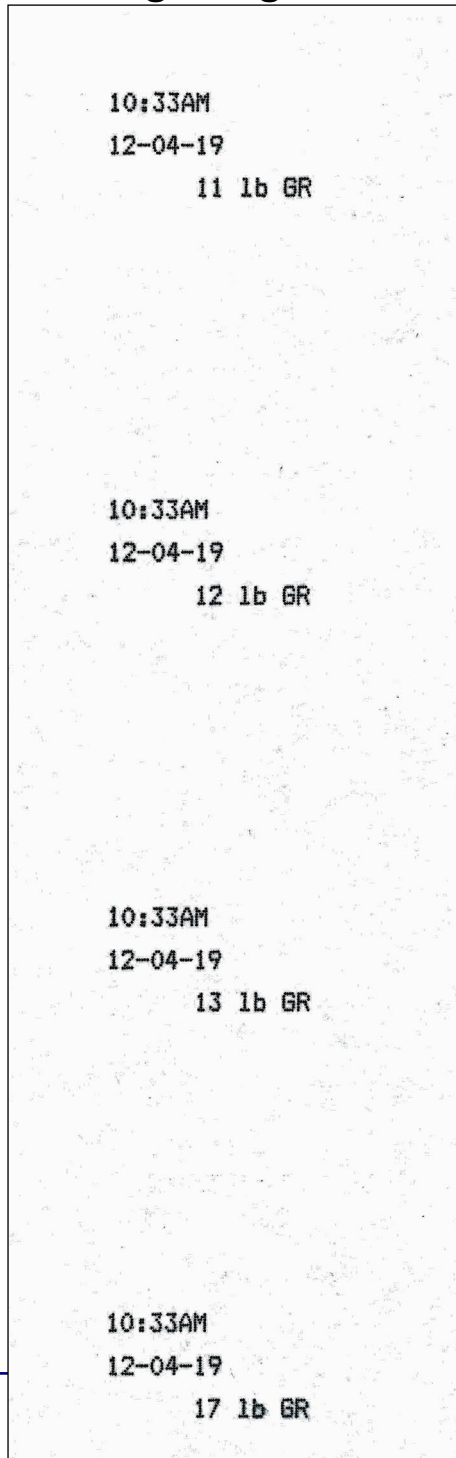

1. Ticket formats can be edited through the PC225X web utility through COM 2 of the instrument.
2. If the desired print is a continuous output of the accumulating weights, the standard GNT ticket format can be used for a given printer. Autoprint can be used with this format, or the PRINT key can be pressed during each weighment. The ticket examples below demonstrate this format.

10:36AM

12-04-19

22 1b GR

6 1b TA

16 1b NT

10:37AM

12-04-19

19 1b GR

6 1b TA

13 1b NT

10:37AM

12-04-19

13 1b GR

3 1b TA

10 1b NT

3. If it is necessary to print a Total Accumulation on the ticket, the following settings can be activated in the ticket format section of the web utility, based on the desired printout:
 - CNT GR: The number of Gross accumulations stored in the instrument
 - CNT NT: The number of Net accumulations stored in the instrument

- GR Acc: The total accumulated gross weight
- NT Acc: The total accumulated net weight

NOTE: Autoprint is not compatible with printing accumulated totals.

4. If a running total is required with a GNT ticket for each weighment, enable either **CNT GR** and **GR ACC** or **CNT NT** and **NT ACC**, depending on the type of weighment.
5. After completing *Step 6* of the weight accumulation procedure, press the **PRINT** key before removing objects from the scale. The full GNT ticket will print with the accumulated totals.

```

09:43AM
12-04-19
      80 lb GR

1 Items GR
      80 lb GR Total

09:44AM
12-04-19
      125 lb GR

2 Items GR
      205 lb GR Total

09:44AM
12-04-19
      95 lb GR

3 Items GR
      299 lb GR Total
  
```

```

10:28AM
12-04-19
      102 lb GR
       16 lb TA
       86 lb NT

1 Items NT
      86 lb NT Total

10:29AM
12-04-19
      103 lb GR
       12 lb TA
       91 lb NT

2 Items NT
      177 lb NT Total

10:30AM
12-04-19
      116 lb GR
       13 lb TA
      103 lb NT

3 Items NT
      281 lb NT Total
  
```

6. To print total accumulation only, deactivate the **Time**, **Date**, **Gross**, **Tare**, and **Net** fields in the web utility.

7. Press the **PRINT** key to print accumulated totals after completing the accumulation.

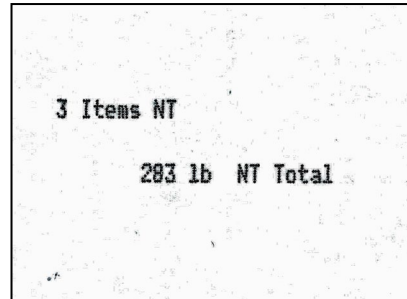
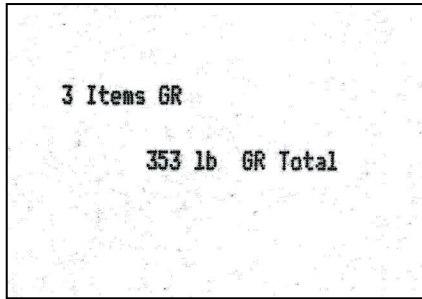

3.6.3. Number of Accumulations

1. Press and hold the **ZERO** key for three (3) seconds.
 - The display will alternate between the number of Gross weight Accumulations "**n**" and the total Gross weight Accumulated for thirty (30) seconds, then return to the **Weigh Mode**.
 - The caret (^) above the printed *Total Weight Accumulated* legend of the display will be seen.
2. Press the **B/G NET** key
 - The display will alternate between the number of Net weight Accumulations "**n**" and the total Net weight Accumulated for thirty (30) seconds, then return to the **Weigh Mode**.
 - The caret (^) above the printed *Total Weight Accumulated* and *NET* legends of the display will be seen.
3. Press the **B/G NET** key to alternate between Gross and Net accumulations or press the **UNITS** key at any time to exit immediately to the **Weigh Mode**.

3.6.4. Clearing the Accumulators

- Press and hold the **BG/Net** key for three (3) seconds.
 - Press **UNITS** key until **CLr.ACC** displays on the Instrument.
1. Press the **ZERO** key to edit or **UNITS** key to skip.
 - Press **UNITS** key to toggle the available settings.
 - **CLr.YES** (Clear the Accumulator)
 - **CLr.NO** (Do NOT Clear the Accumulator)

- Press the **ZERO** key to enter the selection.
2. When complete, the FB2250 will return to the weight mode.

3.6.5. Piece Counting

NOTE: For the following operation to function:

- The Piece Count parameter “Pct” must be set to “Y” (See Section [3.4.3. Programming the Piece Count Feature](#)), the Accumulator parameter “ACC” must be set to “n” (See Section [3.4.3. Programming the Piece Count Feature](#)) and the Peak Hold parameter “P-Hold” must be set to “n”
-

1. Unload the Scale.
2. Press the **ZERO** key, if required, to set scale to “0”.
3. Place the empty weighing container on the Scale Platform.
4. Press the **TARE** key.
 - This stores the container weight only, placing the scale in the **Net Mode**.
 - “0” should display on the instrument and the caret (v) above the printed NET legend of the display will be seen.
5. Press the **B/G NET** key.
 - The Display prompts to “Add 1” number of sample parts to the container.
6. Pressing the **B/G NET** key repeatedly will prompt the user to; “Add 1”, “Add 5”, “Add 10”, “Add 25”, “Add 50”, or “Add 100” sample pieces.
7. Add the required sample pieces to the container, then press the **UNITS** key.
 - The Display will alternate between indicating the net weight and the number of sample pieces.
8. Continue to add the remaining pieces to the container.
 - The display will update and continue to alternate between the net **Weight** and **Number of Pieces**, including the original sample.
9. To Exit to the NET Weigh Mode, press the **B/G NET** key.

3.6.6. Piece Count and Total

NOTE: For the following operation to function:

- The Piece Count parameter “Pct” must be set to “Y” (See [Section 3.4.3.](#)), the Accumulator parameter “ACC” must be set to “Y” (See [Section 3.4.4.](#)) and the Peak Hold parameter “P-Hold” must be set to “n” (See [Section 3.4.5.](#))
-

This feature enables the FB2250 to display the Count and **Net Weight** of the counted items, and to display the Total Count of accumulated items.

1. Unload the Scale.
2. Press the **ZERO** key, if required, to set scale to “0”.
3. Place the empty weighing container on the Scale Platform.
4. Press the **TARE** key.
 - This stores the container weight only, placing the scale in the **Net Mode**.
 - “0” should display on the instrument and the caret (v) above the printed NET legend of the display will be seen.
5. Press the **B/G NET** key.
 - The Display prompts to “Add 1” number of sample parts to the container.
6. Pressing the **B/G NET** key repeatedly will prompt the user to; “Add 1”, “Add 5”, “Add 10”, “Add 25”, “Add 50”, or “Add 100” sample pieces.
7. Add the required sample to the container, then press the **UNITS** key.
 - The Display alternates between indicating the net weight and the number of sample pieces.
8. Continue to add the remaining pieces to the container.
 - The display will update and continue to alternate between the net **Weight** and **Number of Pieces**, including the original sample.
9. Press the **B/G NET** key.
 - The Display will alternate between the “Total” legend and the total **Number of Pieces Accumulated** plus the current **number of pieces**.
 - Press the **B/G NET** key to return to step 6.
10. Press the **UNITS** key to save the new Total in the accumulator and return to the **NET Weigh Mode**.
 - To continue adding to the Total, repeat steps 1-10.
 - To reset the Total see [Section 3.5.13. Clearing the Accumulator](#).

3.6.7. Peak Weight

NOTE: For the following operation to function:

- Peak Hold parameter “P-Hold” must be set to “Y” and the Piece Count parameter “PCT” must be set to “n” and the Accumulator parameter “ACC” must be set to “n”
-

The **Peak Weight** feature records the heaviest stable or unstable load placed on the scale, and the time and date it occurred. To display the current Peak Weight, perform the following:

1. Press and hold the **ZERO** key for three (3) seconds.
 - The display will show the **time** and then alternate between the **date** and **Peak Weight Value**, for thirty (30) seconds, then return to the **Weigh Mode**.

2. Press the **UNITS** key to end the process and immediately exit to the **Weigh Mode**.
 - To reset the Peak Weight value, see [Section 3.5.13. Clearing the Accumulators](#)

3.6.8. Display Total Number of Pieces

Press the Zero key for 3 seconds

Conditional upon programming the operating mode to accumulation, piece count, or piece count and total.

The FB2250 will display total number of pieces, weight, and time out (30 sec).

Conditional upon programming the operating mode to peak hold stable or peak hold unstable.

The FB2250 will display time, date, peak weight, and time out (30 seconds).

SECTION 4: ACCESSORIES

4.1. Attaching an external power supply

4.1.1. Requirements

WARNING: Do not physically install the 4-20mA card until the instrument is configured and calibrated (weight) to the platform.

If the device is passive, an auxiliary power supply must be used to supply the voltage for the current loop. Wire it as shown.

FB2250 Condition	4-20mA analog output
Weight behind zero	3.5 mA
Weight below 4.20 LO	3.5 mA
Weight at 4.20 LO	4.0 mA
Weight at 4.20 HI	20.0 mA
Weight above 4.20 HI	24 mA
Program Mode	Locked on last 4-20mA

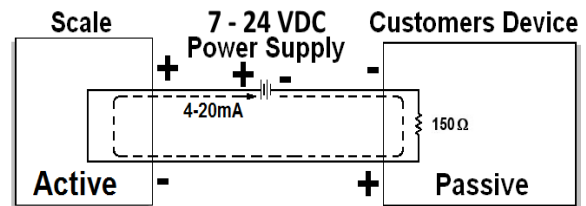

- It is recommended to disable the **Sleep Mode** when the 4-20mA analog is used.
- **Loop Power** should be turned off whenever the FB2250 is turned off.

4.1.2. Programming the Weigh Mode that the Output Tracks

Note: Access to this feature is conditional and depends upon whether it is enabled in the **FB2250 Internal Programming**.

1. Press and hold the **UNITS** key for three (3) seconds.
2. The display will show **4-20**, followed by the current setting.
 - a. Gross
 - b. Net
3. (A) To keep the current setting, press the **UNITS** key.
(B) To change the setting:
 - a. Press the **ZERO** key
 - b. Then use the **UNITS** key to toggle the available settings
 - c. Press the **ZERO** key to select the desired option.

NOTE: The **4-20mA Analog Output** will continue to track the selection regardless of the currently selected Weigh Mode.

4. When complete, the program will advance to the 4mA menu.

4.1.3. Programming the 4mA Weight Value

1. **4.20 Lo** displays, followed by the current setting.
2. Press the **ZERO** key to edit or press the **UNITS** key to skip.
 - a. The most significant digit will be blinking, operate the **UNITS** key to increment the number.
 - b. When the desired value has been obtained, Press the **ZERO** key.
 - c. The next less significant digit will then blink, operate the **UNITS** key to increment the number.
 - d. Repeat steps b and c until the least significant digit has been completed.

*This weight value will result in a **4mA Output**.*

3. When complete, the program will advance to the 20mA menu.

4.1.4. Programming the 20mA Weight Value

1. **4.20 Hi** displays, followed by the current setting.
2. Press the **ZERO** key to edit or press the **UNITS** key to skip.
 - a. The most significant digit will be blinking, operate the **UNITS** key to increment the number.
 - b. When the desired value has been obtained, Press the **ZERO** key.
 - c. The next less significant digit will then blink, operate the **UNITS** key to increment the number.
 - d. Repeat steps b and c until the least significant digit has been completed.

*This weight value will result in a **20mA Output***

3. When complete, the FB2250 will return to weigh mode.

4.2. Fieldbus

Fairbanks Scales offers five different fieldbus devices modules; PROFIBUS®-DP, ControlNet®, DeviceNet™, Modbus®, and ETHERNET/IP.

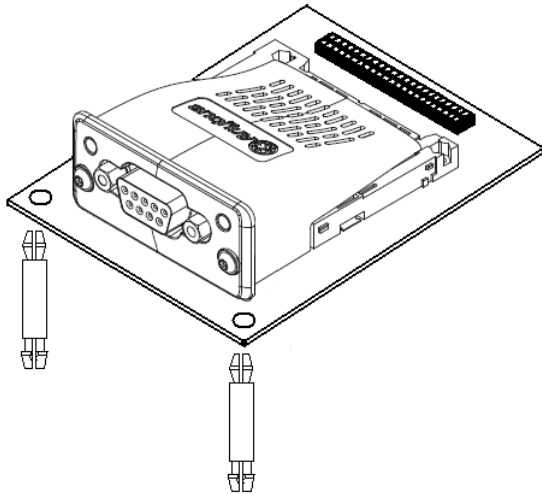

The fieldbus card is factory installed onto an adapter.

4.2.1. ETHERNET/IP Addressing

The ETHERNET/IP module uses Dynamic addressing using DHCP for address requests as the default. The data is transmitted continuously from this module. The IP address may be made static by downloading the IP Configuration Tool software from:

<https://www.anybus.com/support/file-doc-downloads/anybus-compactcom-30-series>

With this utility, it is possible to change the IP, Sub Net and Gateway addresses of an ETHERNET/IP Module. To change an address, double click on the IP address field and enter the changes.

ETHERNET/IP can be easily confused as a simple combination of EtherNet and the Internet Protocol. Instead, it is an **Industrial Application Layer Protocol** used for communication between industrial control systems and their components.

- Such components include Programmable Automation Controller, Logic Controller, or an I/O System.

The “IP” in ETHERNET/IP is not an abbreviation for “Internet Protocol”, but instead, it stands for “**Industrial Protocol**”.

4.3. Fieldbus Connections

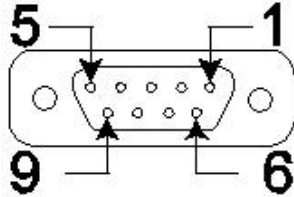

PROFIBUS® DP

Pin	Signal	Description
3	B Line	Positive RxD/TxD, RS485 level
4	RTS	Request to Send
5	GND	Ground (Isolated)
6	+5 Bus Output	+5V termination power (Isolated, short circuit protected)
8	A Line	Negative RxD/TxD, RS485 level

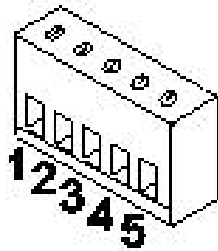

DeviceNet™

Pin	Signal	Description
1	V-	Negative bus supply voltage
2	CAN_L	CAN low bus line
3	SHIELD	Cable shield
4	CAN_H	CAN high bus line
5	V+	Positive bus supply voltage

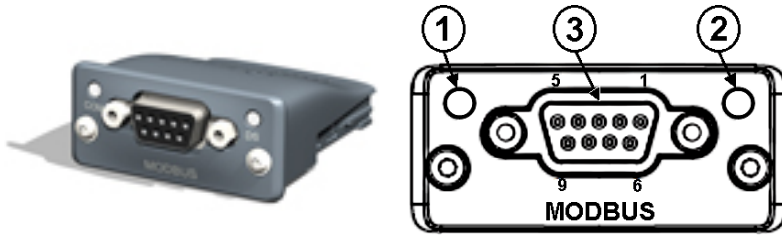

Modbus®

<u>Pin</u>	<u>Signal</u>	<u>Description</u>
1	GND	Bus polarization, ground (isolated)
2	5V	Bus polarizatio power +5V DC (isolated)
3	PMC	Connect to pin #2 for RS-232 operation
5	B-LINE	RS-485 B-Line
7	RX	RS-232 Data Receive
8	TX	RS-232 Data Transmit
9	A-Line	RS-485 A-Line

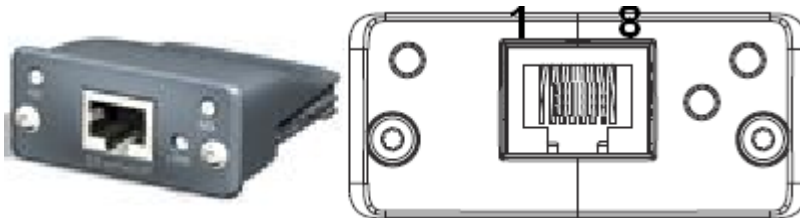

ETHERNET/ IP

Use standard Cat 5 cable (RJ45)

Output data can be verified using the PC2250 utility.

4.3. Fieldbus Connections, continued



ControlNet

Uses a BNC connector cable.

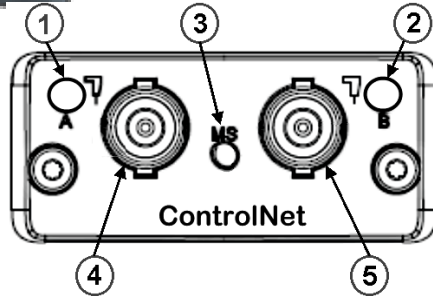

Additional information available at:

<https://www.anybus.com/support/file-doc-downloads/anybus-compactcom-30-series>

4.4. PROFIBUS®-DP Diagnostic LEDs:

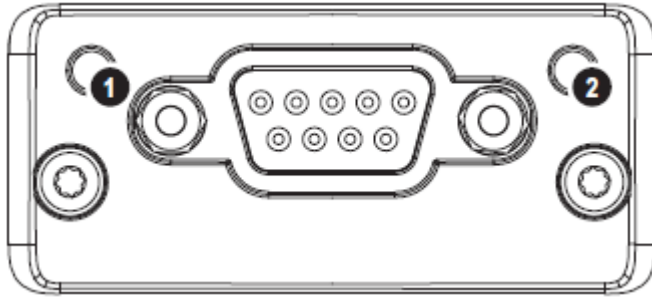

1: Operation Mode LED

2: Module Status LED

Operation Mode LED

State	Description	Comments
Off	Not online / No power	-
Green	Online / Data exchange	-
Flashing Green	Online, clear	-
Flashing Red (1 flash)	Parameterization error	See Parameterization data handling
Flashing Red (2 flashes)	PROFIBUS configuration error	See Configuration data handling

Module Status LED

State	Description	Comments
Off	No power or not initialized	Module state="SETUP" or NW_INIT"
Green	Initialized	Module has left the NW_INIT state
Flashing Green	Initialized, diagnostic event(s) present	Extended diagnostic bit is set
Red	Exception error	Module state = EXCEPTION

4.5. DeviceNet™ Diagnostic LEDs:

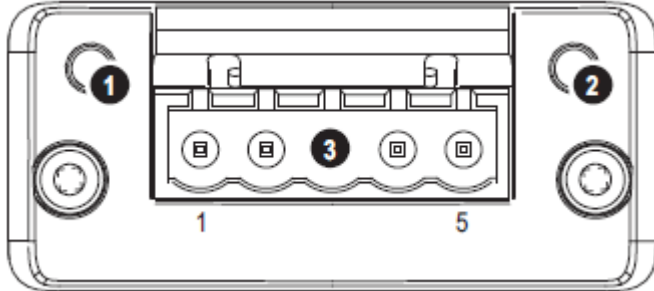

- 1: Network Status LED
- 2: Module Status LED
- 3: DeviceNet™ connector

Network Status LED

State	Description
Off	Not online / No power
Green	Online, one or more connections established
Flashing Green (1 Hz)	Online, no connections established
Red	Critical link failure
Flashing Red (1 Hz)	One or more connections timed out
Alternating Red/Green	Self-test

Module Status LED

State	Description
Off	No power
Green	Operating in normal condition
Flashing Green (1 Hz)	Missing/incomplete configuration / Device needs commissioning
Red	Unrecoverable fault(s)
Flashing Red (1 Hz)	Recoverable fault(s)
Alternating Red/Green	Self-test

4.6. Modbus® Diagnostic LEDs:

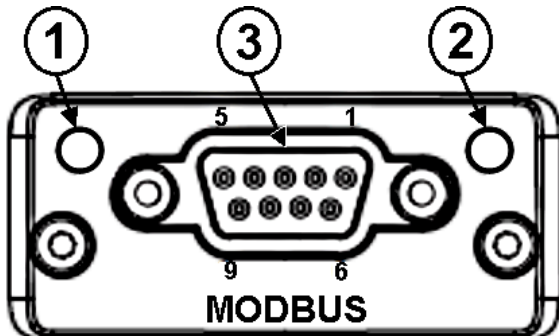

- 1: Communication LED
- 2: Device Status LED
- 3: Modbus® Interface

Communication LED

<u>State</u>	<u>Description</u>
Off	No power - OR - no traffic
Yellow	Frame reception or transmission
Red	A fatal error has occurred

Device Status LED

<u>State</u>	<u>Description</u>
Off	Initializine – OR – no power
Green	Module initialized, no error
Red	Internal error – OR –major unrecoverable fault
Red, Single flash	Communication fault or configuration error Case 1: Invalid settings in Network Configuration error Case 2: Settings in Network Configuration Object has been changed during runtime (i.e. the settings do not match the currently used configuration)
Red, Double flash	Application diagnostics available

4.7. ETHERNET / IP Diagnostic LEDs:



- 1: Network Status LED
- 2: Module Status LED
- 3: Link/Activity
- 4: Ethernet Interface (RJ 45) (Standard Cat 5 cable)

Network Status LED

State	Description
Off	Not online / No power
Green	Online, one or more connections established
Flashing Green	Online, no connections established
Red	Duplicate IP address, FATAL error
Flashing Red	One or more connections timed out

Module Status LED

State	Description
Off	No power
Green	Controlled by a scanner in Run state
Flashing Green	Not configured, or Scanner in idle state
Red	Major fault (EXCEPTION-state, FATAL error, etc.)
Flashing Red	Recoverable fault(s)

LINK / Activity LED

State	Description
Off	No link, no activity
Green	Link established
Green, flickering	Activity

4.8. ControlNet

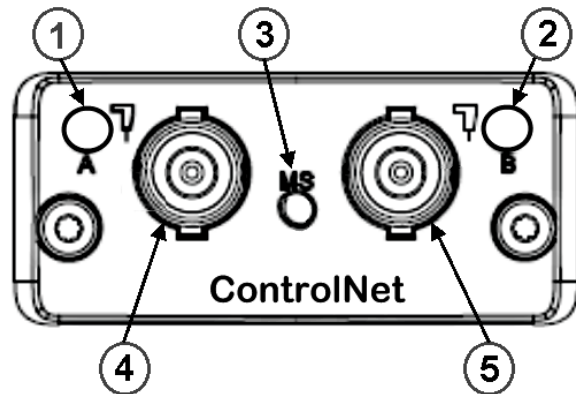

No.	DESCRIPTION
1	Network Status LED A
2	Module Status LED
3	Network Status LED B
4	ControlNet Connector A
5	ControlNet Connector B

Network Status LEDS

<u>LEDS</u>	<u>State</u>	<u>Description</u>
A and B	Off	Not online / No power
	Flashing Red (1 Hz)	Incorrect node configuration, duplicate MAC ID etc.
	Alternating Red/Green	Self test of bus controller
	Red	Fatal event or faulty unit
A or B	Off	Channel is disabled
	Alternating Red/Green	Invalid link configuration
	Flashing Green (1 Hz)	Temporary errors (node self-corrects) or node is not configured to go online.
	Green	Normal operation
	Flashing Red (1 Hz)	Media fault or no other nodes on the Network

Module Status LED

<u>State</u>	<u>Description</u>
Off	No power
Green	Operating in normal condition, controlled by a Scanner in RUN state.
Flashing Green(1Hz)	The module has not been configured or the Scanner is in the Idle state.
Red	Unrecoverable fault(s), EXCEPTION,
Flashing Red(1Hz)	Media fault or no other nodes on the Network

SECTION 5: SERIAL COMMUNICATION WIRING

5.1. JP3 Jumper Configuration:

JP3		JP3	RS232	RS485	RS422*	Port
1	2	1-2	out	120 Ω resistor	120 Ω resistor	Com1
3	4	3-4	out	in	out	Com1
5	6	5-6	out	in	out	Com1
7	8					
9	10	7-8	out	in	out	Com2
11	12	9-10	out	in	out	Com2
		11-12	out	120 Ω resistor	120 Ω resistor	Com2

120 ohm termination resistors required if the receiver is the last node of the network

5.2. TB4 Connections, COM1 (A), COM2 (B), and COM2 (C)

TB4 (A)	RS232		RS485	RS422*	PORT
1	Rx – Receive Data		(-) RS485	RS422 (-) Rx	COM1
2	Tx – Transmit Data		(-) RS485	RS422 (-) Tx	COM1
3	CTS – Clear-to-Send		(+) RS485	RS422 (+) RX	COM1
4	GND -- Ground		GND	GND	COM1
5	RTS – Ready-to-Send		(+) RS485	RS422 (+) Tx	COM1
TB4 (B)	RS232	DB9 ABS ONLY	RS485	RS422*	PORT
1	Rx – Receive Data	2	(-) RS485	RS422 (-) Rx	COM2
2	TX – Transmit Data	3	(-) RS485	RS422 (-) Tx	COM2
3	CTS – Clear-to-Send	8	(+) RS485	RS422 (+) Rx	COM2
4	GND – Ground	5	GND	GND	COM2
5	RTS – Ready-to-Send	7	RS485	RS422 (+) Tx	COM2
TB4 (C)	20MA		RS485	RS422	PORT
1	(+) TX – Transmit Passive, 20mA Output				COM2
2	(-) TX Passive, 20mA Output				COM2
3		(+) 7.5V Bluetooth® Technology Supply			

*Port should be set to RS485.

SECTION 6: PRINTER INSTALLATION

6.1. 3550 Tape Printer

Transmission	RS232
Baud Rate	9600
Data Bits	8
Stop Bit	1
OUTPUT	"BUTTON" for Print Key

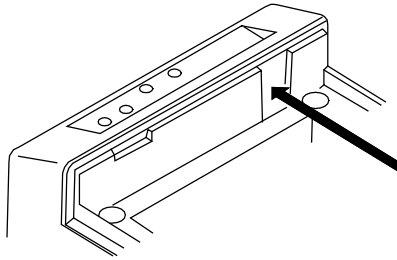
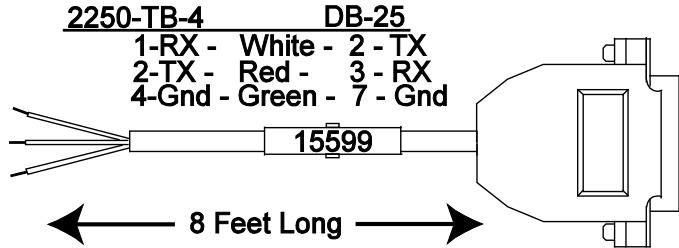

DS2	ON	OFF
1	X	
2	X	
3	X	
4		X
5	X	
6	X	
7		X
8		X

DS1	ON	OFF
1		X
2	X	
3	X	
4	X	
5		X
6		X
7		X
8	X	
9		X
10		X

6.2. TM-U220 Tape Printer

This is the TM-U220 Tape Printer (non-DAT, white case).

Transmission	RS232
Baud Rate	9600
Data Bits	8
Stop Bit	1
OUTPUT	"BUTTON" for Print Key

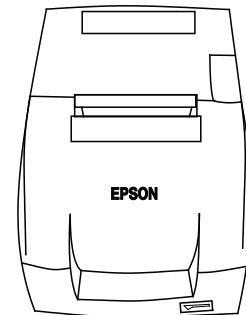

Bottom of TM-U220 Tape Printer

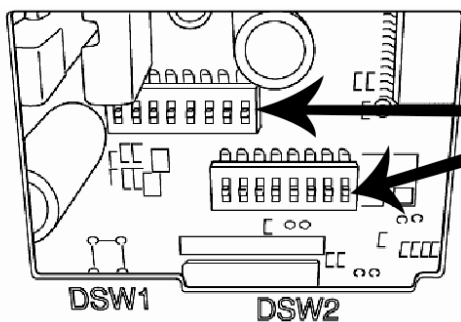

DS1	ON/OFF
1	OFF
2	OFF
3	OFF
4	OFF
5	OFF
6	OFF
7	OFF
8	OFF

DS2	ON/OFF
1	OFF
2	OFF
3	OFF
4	OFF
5	OFF
6	OFF
7	OFF
8	OFF

6.3. Okidata 186 T Form Printer

The FB2250 should be programmed for RS-232, 9600 baud, 8 data bits, and 1 stop bit. The OUTPUT setting should be "BUTTON" for the Print key.

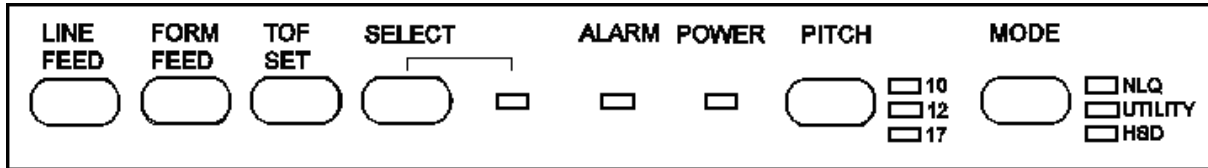

To change Menu Settings:

1. To enter MENU MODE, press and hold SELECT while turning on the printer. The "12" and "UTILITY" LEDs will blink.
2. With the printer in the Menu Mode, press SELECT to print the complete menu. The current default settings print out. It is recommended to use tractor fed paper. NOTE: The printed menu selections are different for each emulation mode.
3. Press LINE FEED to select the relevant group that needs to be changed (the group is the left-hand column on the Menu printout).
4. Press FORM FEED to select the relevant item within the selected group (the Item is the center column on the Menu printout).
5. Press TOF SET to cycle through the settings available for the item you want to change (the settings are the right-hand column on the Menu printout).
6. To continue making changes: press LINE FEED for the next group or press FORM FEED for the next item. Repeat as needed until you are finished changing settings.
7. Press PITCH and MODE together to save the changes and exit the Menu Mode.

NOTES:

Exiting the Menu Mode by turning off the printer will cancel any changed settings.

Printed menu changes per Printer Emulation Mode. If printer emulation mode is NOT set to ML, set this first, then reprint the menu. Then set menu as follows:

6.3. Okidata 186 T Form Printer, Continued

(GROUP) (press LINE FEED to change)	(ITEM) (press FORM FEED to change)	(SET) (press TOF SET to change)
Printer Control	Emulation Mode	ML
Font	Print Mode	Utility
Font	DRAFT Mode	SSD
Font	Pitch	10 CPI
Font	Proportional Spacing	No
Font	Style	Normal
Font	Size	Single
Symbol Sets	Character Set	Standard
Symbol Sets	Language Set	American
Symbol Sets	Zero Character	Slashed
Symbol Sets	Code Page	USA
Vertical Control	Line Spacing	6 LPI
Vertical Control	Skip Over Perforation	No
Vertical Control	Page Length	11"
Set-Up	Graphics	Bi-directional
Set-Up	7 or 8 Bits Graphics	7
Set-Up	Receive Buffer Size	128K
Set-Up	Paper Out Override	No
Set-Up	Paper Registration	0
Set-Up	7 or 8 Bits Data Word	8
Set-Up	Operator Panel Function	Full Operation
Set-Up	Reset Inhibit	No
Set-Up	Print Suppress Effective	Yes
Set-Up	Auto LF	No
Set-Up	Print DEL Code	Yes
Set-Up	Time Out Print	Invalid
Set-Up	Auto Select	No
Set-Up	Impact Mode	Normal
Parallel I/F	I-Prime	Buffer Print
Parallel I/F	Pin 18	+5v
Parallel I/F	Bi-Direction	Enable

6.3. Okidata 186 T Form Printer, Continued

Serial PCB Assy Switch Settings: (SW1) (** indicates typical Fairbanks setting)

<u>Parity Type</u>	<u>Switch 1 (SW1)</u>
** Odd parity	ON
Even parity	OFF

<u>Parity</u>	<u>Switch 2 (SW1)</u>
** No parity	ON
With parity	OFF

<u>Data Bits</u>	<u>Switch 3 (SW1)</u>
** 8 Bits	ON
7 Bits	OFF

<u>Protocol</u>	<u>Switch 4 (SW1)</u>
Ready/Busy	ON
** X-ON, X-OFF	OFF

<u>Test Select</u>	<u>Switch 5 (SW1)</u>
** Circuit	ON
Monitor	OFF

<u>Mode Select</u>	<u>Switch 6 (SW1)</u>
** Print mode	ON
Test mode	OFF

<u>Busy Line Selection</u>	<u>Switch 7, 8 (SW1)</u>
SSD- Pin 11	OFF, ON
SSD+ Pin 11	OFF, OFF
** DTR- Pin 20	ON, ON
RTS- Pin 4	ON, OFF

(SW2) (** indicates typical Fairbanks setting)

6.3. Okidata 186 T Form Printer, Continued

<u>Transmission Speed</u>	<u>Switches 1, 2, 3 (SW2)</u>
19,200 bps	ON, ON, ON
** 9,600 bps	OFF, ON, ON
4,800 bps	ON, OFF, ON
2,400 bps	OFF, OFF, ON
1,200 bps	ON, ON, OFF
600 bps	OFF, ON, OFF
300 bps	ON, OFF, OFF
110 bps	OFF, OFF, OFF

<u>DSR Input Signal</u>	<u>Switch 4 (SW2)</u>
Active	ON
** Inactive	OFF

<u>Buffer Threshold</u>	<u>Switch 5 (SW2)</u>
32 bytes	ON
** 256 bytes	OFF

<u>Busy Signal Timing</u>	<u>Switch 6 (SW2)</u>
** 200 ms minimum	ON
1 second minimum	OFF

<u>DTR Signal</u>	<u>Switch 7 (SW2)</u>
** Space after power on	ON
Space when printer is selected	OFF

<u>Not Used</u>	<u>Switch 8 (SW2)</u>
**	OFF

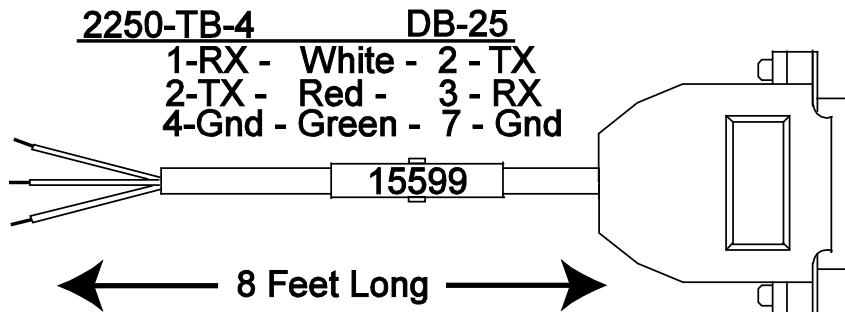

6.4. Okidata 420 Form Printer

The FB2250 should be programmed for RS 232, 9600 baud, 8 data bits, and 1 stop bit. The OUTPUT setting should be "BUTTON" for the Print key.

To change Menu Settings:

SEL						
SEL		LF	FF/LOAD	TEAR	PARK	QUIET
MENU	SHIFT	Micro Feed Down	Micro Feed Up			TOF
EXIT		GROUP	ITEM	SET	PRINT	
POWER	ALARM		MENU			

1. To enter MENU MODE, press and hold the SHIFT key while pressing the SELECT key. The "MENU" legend will be illuminated while in the menu mode.

2. With the printer in the Menu Mode, press PRINT to print the complete menu. The current default settings print out. It is recommended to use tractor fed paper.

NOTE: The printed menu selections are different for each emulation mode.

3. Press GROUP to select the relevant group that needs to be changed (the group is the left-hand column on the Menu printout).

4. Press ITEM to select the relevant item within the selected group (the Item is the center column on the Menu printout).

5. Press SET to cycle through the settings available for the item you want to change (the settings are the right-hand column on the Menu printout).

6. Press and hold the SHIFT key while pressing the SELECT key exit the Menu Mode.

Note: If you turn off the printer before exiting the menu mode, any changes will be lost.

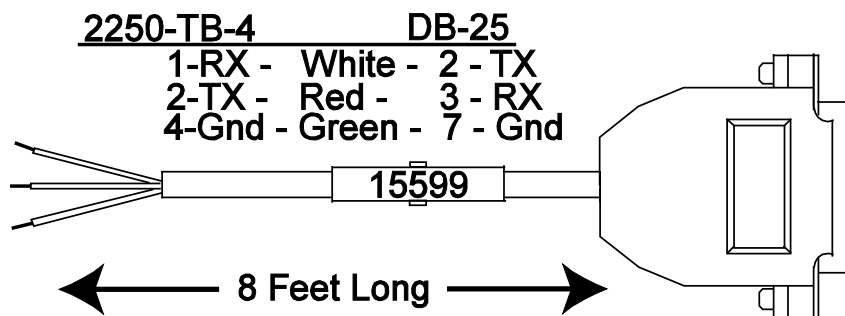

6.4. Okidata 420 Form Printer, Continued

(GROUP) (press LINE FEED to change)	(ITEM) (press FORM FEED to change)	(SET) (press TOF SET to change)
Printer Control	Emulation Mode	IBM PPR
Font Font Font Font Font Font	Print Mode DRAFT Mode Pitch Proportional Spacing Style Size	Utility HSD 10 CPI No Normal Single
Symbol Sets Symbol Sets Symbol Sets Symbol Sets	Character Set Language Set Zero Character Code Page	Set 1 American Slashed USA
Rear Feed Rear Feed Rear Feed Rear Feed	Line Spacing Form Tear-off Skip Over Perforation Page Length	6 LPI Off No 11"
Bottom Feed Bottom Feed Bottom Feed Bottom Feed	Line Spacing Form Tear-off Skip Over Perforation Page Length	6 LPI Off No 11"
Top Feed Top Feed Top Feed Top Feed	Line Spacing Form Tear-off Skip Over Perforation Page Length	6 LPI Off No 11"

6.4. Okidata 420 Form Printer, Continued

Set-Up	Graphics	Uni-directional
Set-Up	Receive Buffer Size	64K
Set-Up	Paper Out Override	No
Set-Up	Print Registration	0
Set-Up	Operator Panel Function	Full Operation
Set-Up	Reset Inhibit	No
Set-Up	Print Suppress Effective	Yes
Set-Up	Auto LF	No
Set-Up	Auto Select	No
Set-Up	SI Select Pitch (10CP)	17.1 CPI
Set-Up	SI Select Pitch (12CPI)	12 CPI
Set-Up	Time Out Print	valid
Set-Up	Auto Select	No
Set-Up	Centering Position	DEFAULT
Set-Up	ESC SI Pitch	17.1 CPI
Set-Up	Power Saving	Enable
Set-Up	Power Save Time	5 Min
Parallel I/F	I-Prime	Buffer Print
Parallel I/F	Pin 18	+5v
Parallel I/F	Bi-Direction	Enable
Serial I/F	Parity	None
Serial I/F	Serial Data 7/8 Bits	8 Bits
Serial I/F	Protocol	X-On/X-Off
Serial I/F	Diagnostic Test	No
Serial I/F	Busy Line	SSD-
Serial I/F	Baud Rate	9600 BPS
Serial I/F	DSR Signal	Invalid
Serial I/F	DTR Signal	Ready on Pwr up
Serial I/F	Busy Time	200 ms

6.5. TM-U295 Ticket Printer

The FB2250 should be programmed for RS232, 9600 baud, 8 data bits, and 1 stop bit. The OUTPUT setting should be "BUTTON" for the Print key.

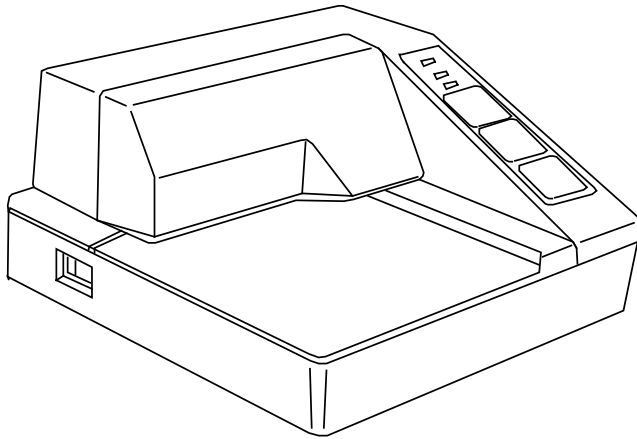

Set the printer's dip switches per the following:

1 and 3 on, the rest off.

Cycle power to the printer after making switch changes.

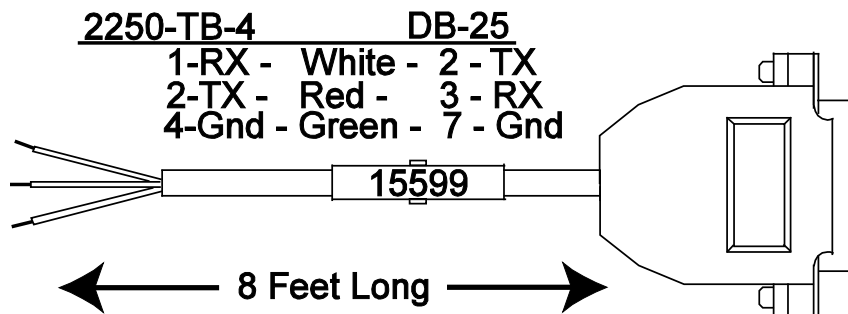

6.6. TM-U590 Ticket Printer

The FB2250 should be programmed for RS232, 9600 baud, 8 data bits, and 1 stop bit. The OUTPUT setting should be "BUTTON" for the Print key.

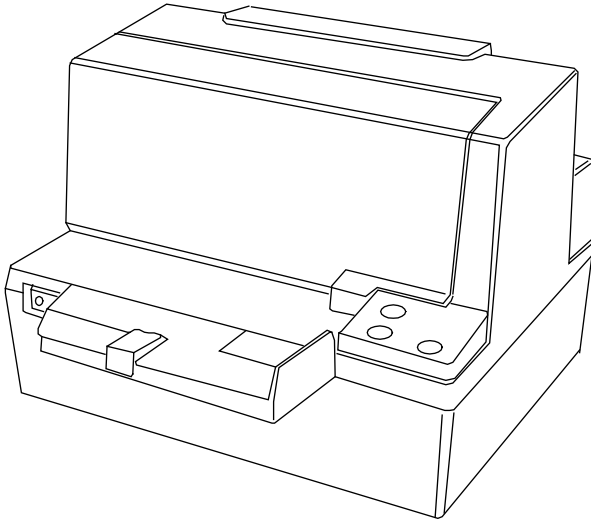

Set the printer's dip switches per the following:

DSW 1: 1, 3, and 7 on only.

DSW 2: All off.

Cycle power to the printer after making switch changes.

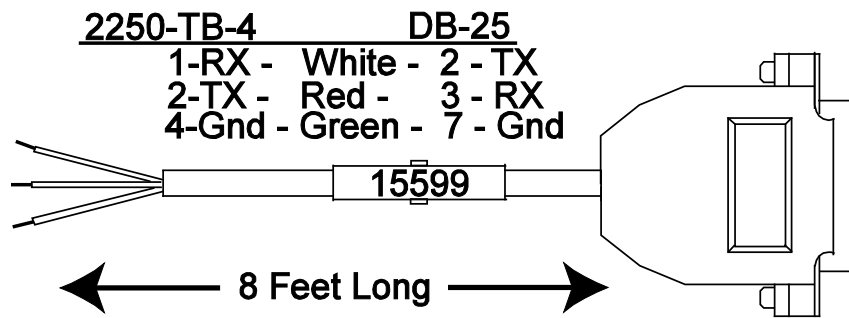

6.7. 1600 Series Remote Display

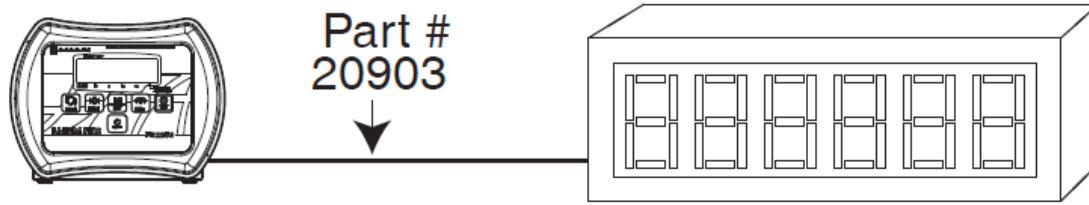

Using the **20mA Serial Current Loop Output** will allow transmission distances up to **1000 cable feet**.

– **Interface Cable (20903)** is recommended.

	Port 2
Protocol	C-Loop
Baud Rate	9600
Data Bits	8
Parity	None
Stop Bit	1
Output Type	rDisp

The 1600 Series remote display must be wired for **20mA Active** and programmed to match the FB2250.

– Wiring to the FB2250: **TB4 (C)** to the **Remote Display** (see section 2.7 or 5.4).

1	Tx + Passive 20mA Output
2	Tx – Passive 20mA Output

Wire the 1600/1500 Series **Remote Display** to the FB2250 as shown in this diagram.

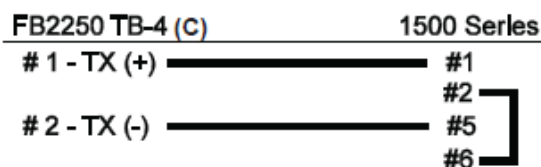
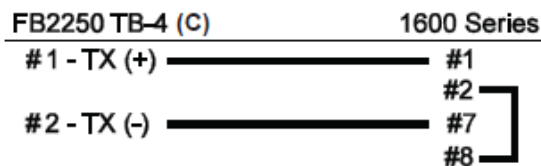

6.8. FB2250 Remote Display

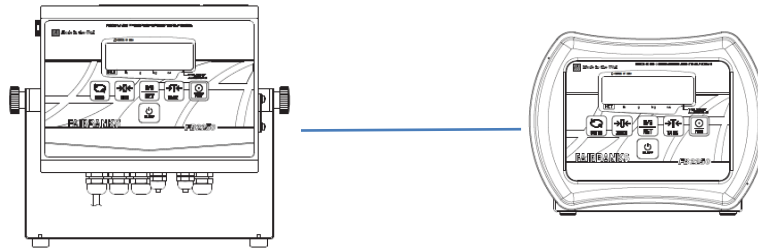

	FB2250 (Master)	FB2250 (Remote)
Port	1 or 2	1
Protocol	RS232	RS232
Baud Rate	9600	9600
Data Bits	8	8
Parity	none	none
Stop Bit	1	1
Output Type	POLL	Rd2250

- See Sections starting at [3.2.3. Port 1](#) configuration programming.
- See Sections starting at [3.2.9. Port 2](#) configuration programming.
- See [Appendix III](#) for wiring information.
- See [Appendix IV](#) for Remote Display Active Keys information.

Note: Remote Display will blank when connection to Master is terminated.

SECTION 7: PC2250 UTILITY SOFTWARE

7.1. Introduction

The PC2250 utility software program can be used to set up and configure the FB2250. It is required in order to program certain features such as custom units and custom ticket vector programming. The F2250 uses port 2 to communicate to the computer.

7.2. Wiring

Computer DB9 Pin 3 (TX) ----- FB2250 TB4 Pin 6 (RX)
Computer DB9 Pin 2 (RX) ----- FB2250 TB4 Pin 7 (TX)
Computer DB9 Pin 5 (GND) ----- FB2250 TB4 Pin 9 (GND)

7.3. Communication Settings

1. Configure the FB2250 Port 2 as noted in Table 1 below:
 - a. Press and hold the Internal Program Switch until **SetUP** displays. (see section 3.2)
 - b. Use the UNITS key to scroll through each menu item until **Port 2** displays
 - c. See [Sections 3.5.9 – 3.5.14](#) for configuration instructions.
 - d. Exit to weigh mode.

Baud Rate	9600
Data Bits	8
Parity	None
Stop Bit	1
Mode	Continuous

Table 1

2. On the PC Launch the **PC2250.exe** file.
 - An image of the FB2250 will display on the computer monitor.

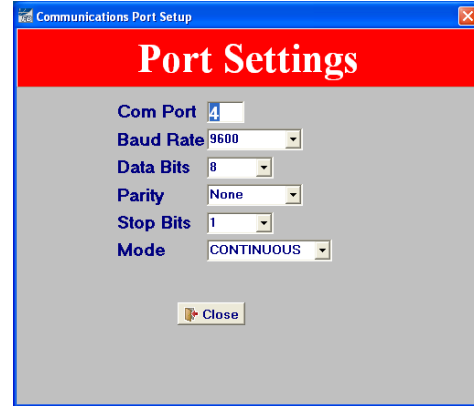

3. Access the **COM Port Settings** of the computer by pressing **F2**.
4. Configure the Com Port connected to the FB2250 via the pop-up menu to match the settings in Table 1 above.
5. Close the pop-up menu when complete.
6. To the left side of the weight display, the legend “**CONNECTED**” with a rotating baton will be displayed.
 - The weight display will duplicate what is shown on the FB2250.
7. Left-clicking the mouse on any key will transmit that command to the FB2250.
 - This excludes the **PRINT key**.
 - The legend “**COMMAND SENT!**” will display at the right.
 - Mouse-clicking the **ON/OFF** key will terminate the PC2250 software program.

Files

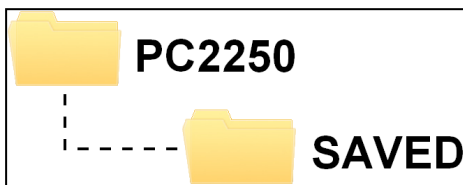

The default folder for all saved/uploaded parameter files is PC2250\SAVED

7.4. Menu Bar

The PC2250 menu bar is located at the bottom of the display.

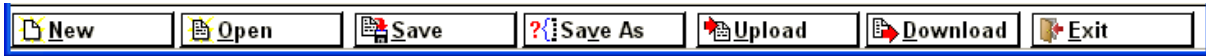

NEW: Loads the Parameters Menu with FB2250 default settings.

OPEN: Opens the SAVED folder to select a file.

SAVE: Saves the currently named file.

SAVE AS: Saves the current file and prompts for a file name.

UPLOAD: Uploads the current FB2250 settings to the PC2250.

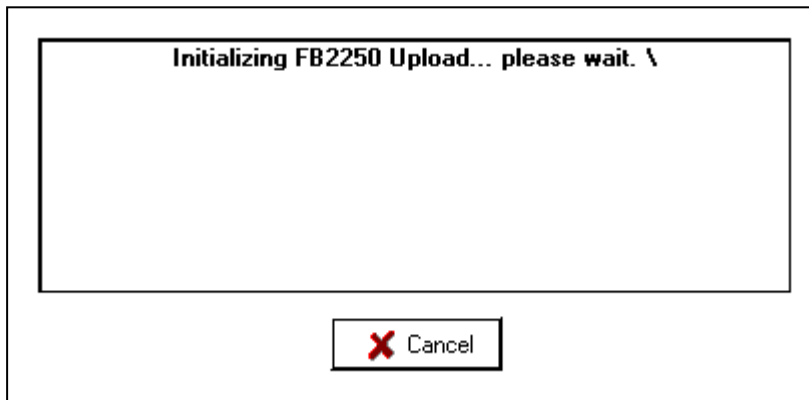

The FB2250 will display "PC". Press the Program switch inside the FB2250.



When complete, click the "OK" button.

DOWNLOAD: Downloads the current PC2250 settings to the FB2250.

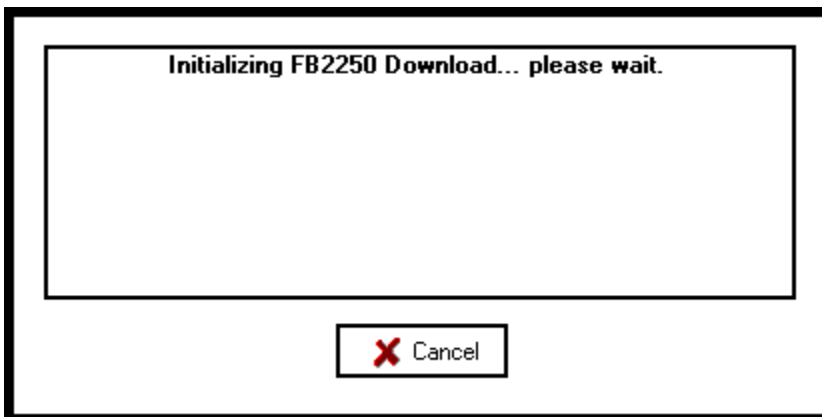

The FB2250 will display "PC". Press the Program switch inside the FB2250.

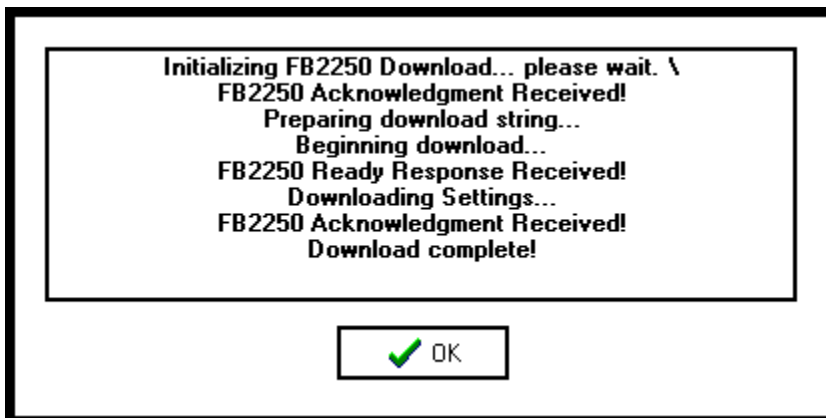

When complete, click the "OK" button.

EXIT: Closes the Parameter Editor.
Press or Click F4 to enter the Parameters Editor.

7.5. Configuration

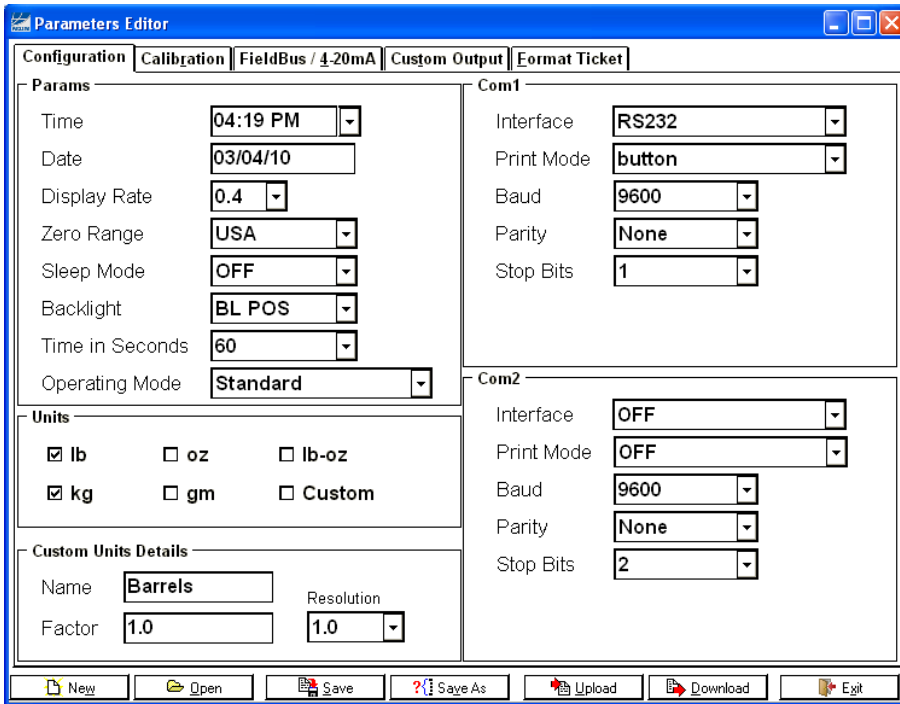

Programming features is accomplished by using the mouse and:

- Clicking the data item to highlight it, and then typing the replacement data.
- Clicking the drop down arrow and selecting an available item.
- Clicking to provide a checkmark, which indicates the selection is active.
- The custom unit factor is a conversion factor of the current primary weight data.

Custom Unit Programming example:

To convert lbs to dry barrels enter the conversion factor, resolution and custom legend, in the PC2250 program. The current primary weight will be multiplied by the conversion factor, rounded off to the custom resolution and printed with a custom legend.

7.6. Calibration

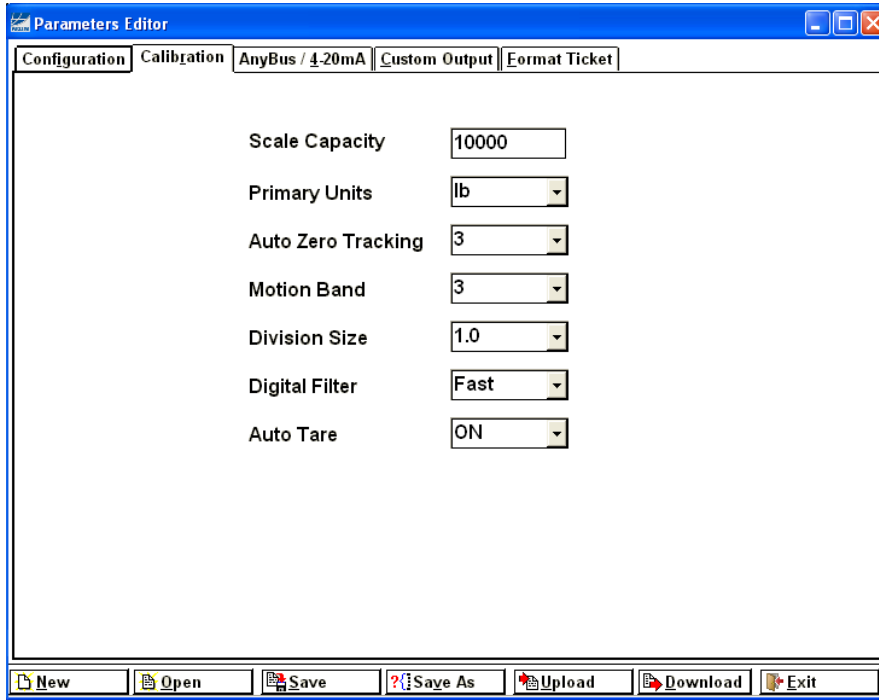

Settings include:

- Scale capacity
- Primary Units
- Auto Zero Tracking
- Motion Band (BAL)
- Division Size
- Digital Filter
- Auto Tare settings.

Actual test weight calibration is performed with the FB2250 front panel keys.

7.7. First time Connection Using PC225X PC Utility and FB225X ETHERNET TCP/IP option

1. With the FB225X connected to the ethernet network, launch the PC225X PC Utility from the PC on the same network as the FB225X.

2. Change the interface from RS232 to TCP/IP by clicking on the button. 

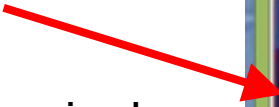
3. Select the PC Utility type based on the instrument you will be connecting to. Choose PC2250 or PC2255. 



NOTE: If the ethernet card has been previously configured, skip to step 23.

4. Click F4 to open the Configuration window.
5. Select the **IP CONNECTION** Tab.

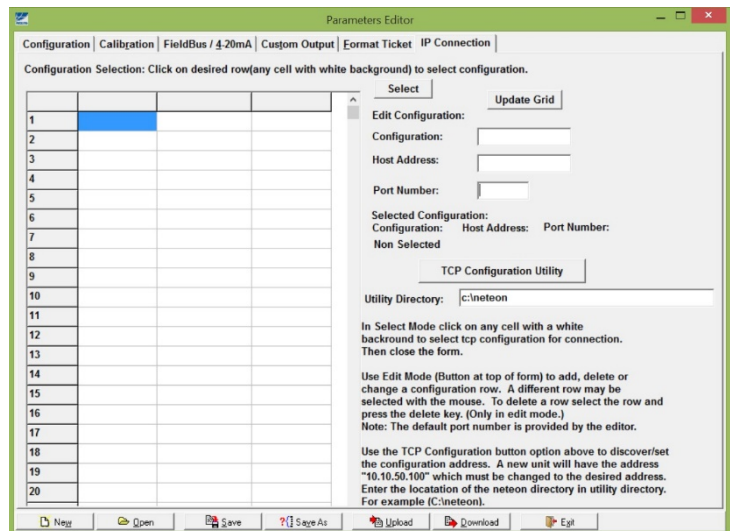

6. Click the **TCP CONFIGURATION UTILITY** button.



7. The NETEON Utility will open.

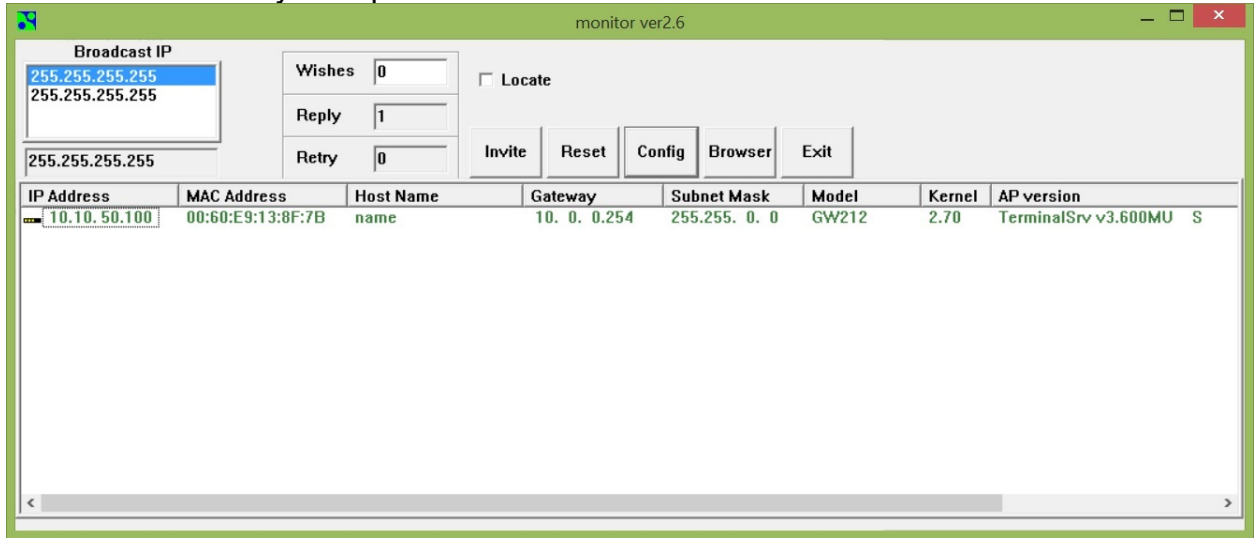

8. The default IP (10.10.50.100 or 10.0.50.100) of the ethernet device should show.

9. Highlight the IP address shown by clicking on it.

10. Select the **CONFIG** button. A new dialog box will open.

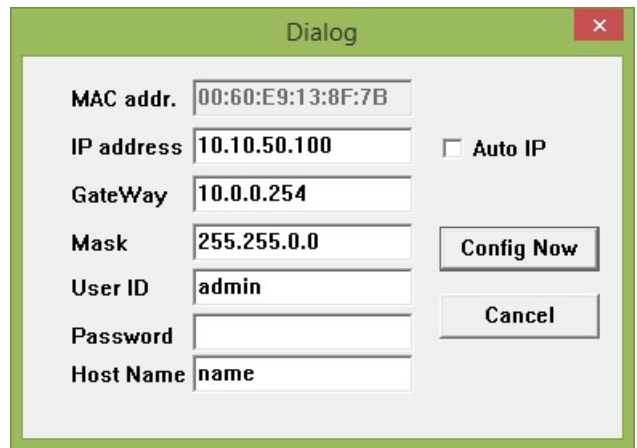

11. Obtain network setting details from the customer's IT personnel and enter the information in the dialog box.

a. **NOTE:** AUTO IP sets the card to DHCP

12. Set the USER ID and PASSWORD

a. Default = admin with no password

13. Highlight the IP address shown by clicking on it.

14. Click the **CONFIG NOW** button to write the change to the ethernet card.

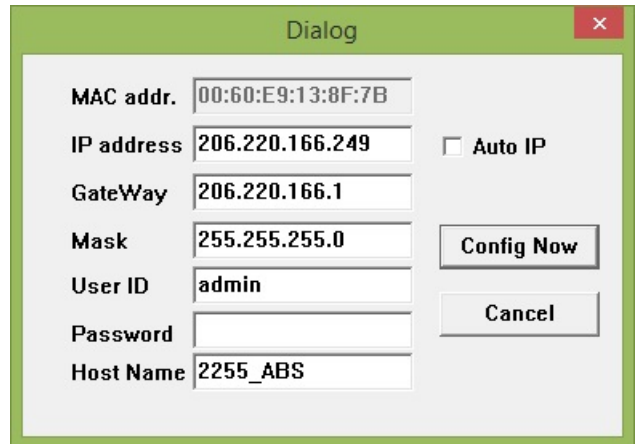

15. Click the **BROWSER** button.



16. You will be prompted for the USER ID and PASSWORD previously entered.

17. The **OVERVIEW** window will open showing the current addresses and settings for the ethernet card.

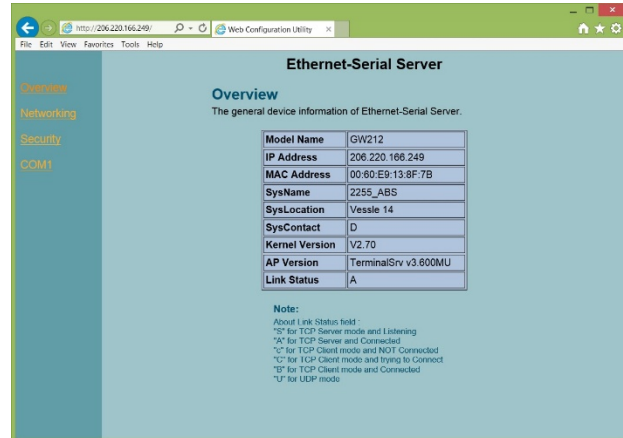

18. If additional network configuration is required, click the **NETWORKING** link.

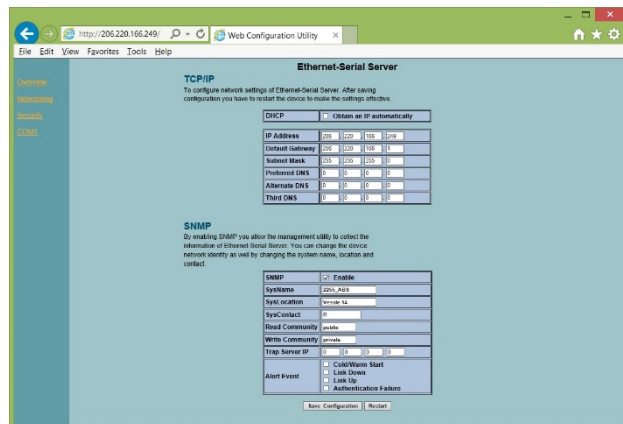

19. To change the PASSWORD, click the **SECURITY** link.

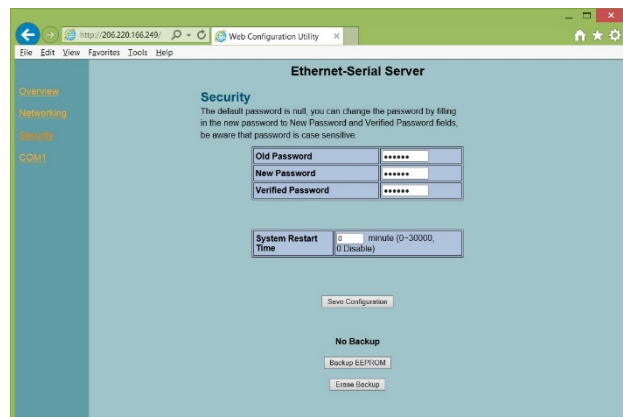

20. Do NOT make any changes under the COM1 link.

21. Close the browser window when you are done.

22. Click the **EXIT** button to close the configuration utility.

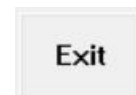

23. Return to the PC225X Utility and select the **IP CONNECTION** tab.
24. If the **SELECT** button is available, proceed to the next step, if it is not click on the **EDIT** button then proceed to the next step.
25. In the **CONFIGURATION** field, enter a human readable name to identify the FB225X instrument to connect to.

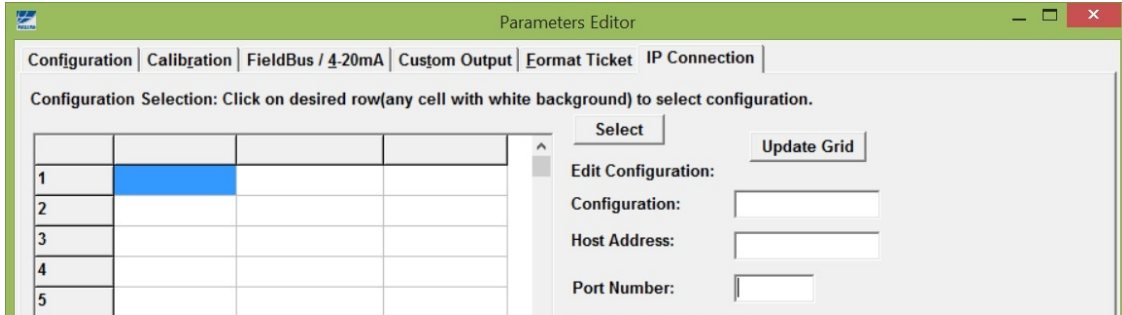

26. In the **HOST ADDRESS** field, enter the IP address for the FB225X being connected.
27. Default **PORT NUMBER** is 4660.
28. Once complete, select **UPDATE GRID**.

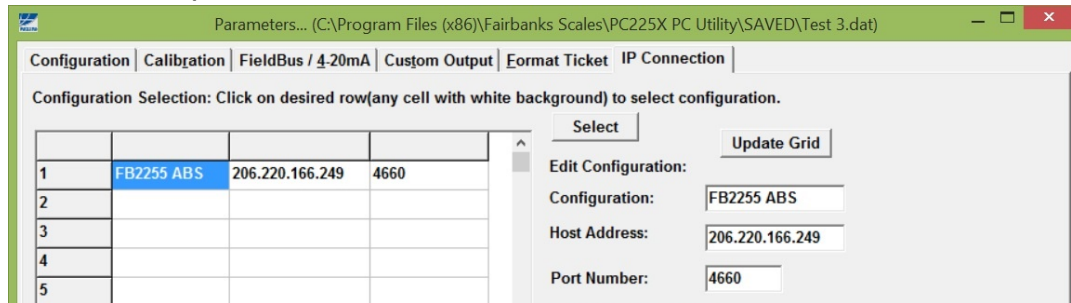

29. Save the PC225X Configuration file using the **SAVE AS** button.
30. Press **EXIT** to close the Configuration tool.
31. Weight should now display on the PC225X Utility.
32. The Utility will display the current IP Connect selected next to the TCP/IP button.
33. You can make Configuration changes, Upload and Download files from the PC225X Utility and the FB225X instrument.

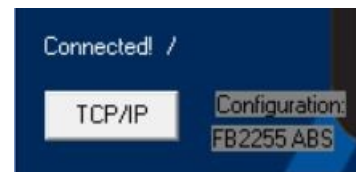

7.8. Fieldbus

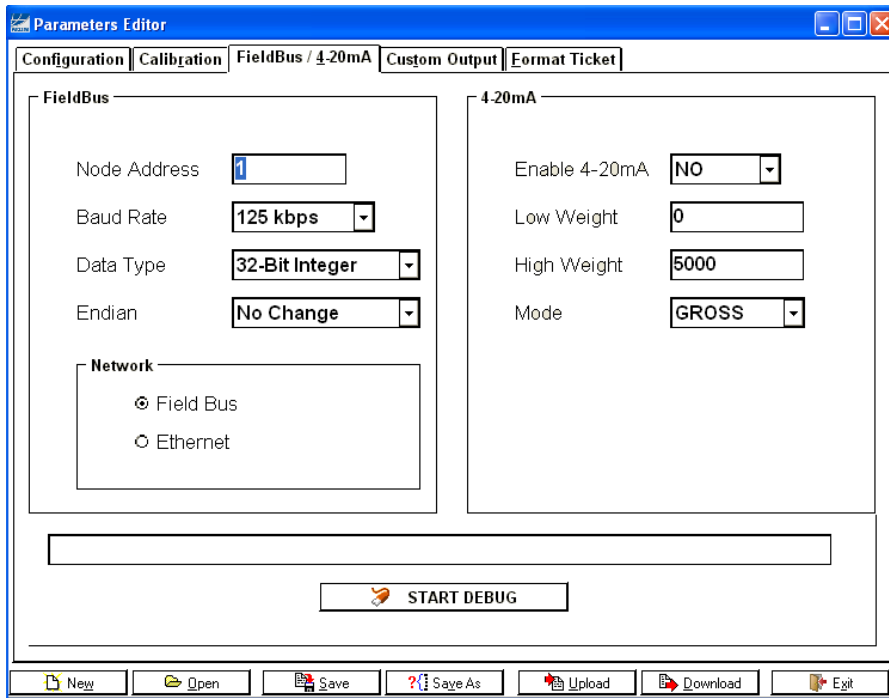

The **Anybus Module** is set up using the **PC2250 Program** and configures the following parameters listed below. The FB2250 will automatically detect the Anybus module installed. No additional programming is required except the following parameters if necessary. The remainder of the fieldbus configuration and programming is performed on the fieldbus network side by the customer's network personnel.

PORT 20

As part of the ETHERNET IP specification, the fieldbus device uses Port 20. This port cannot be changed. This is to ensure other devices on the network are able to communicate with each other.

Node Address

Enter the Node Address of the Module. This is typically furnished by the customer.

Baud Rate

Most anybus modules can automatically detect the network speed by using the Auto Baud feature. DeviceNet uses 125 bps, 250bps or 500bps.

Data Type

Data can be setup to output a 32 bit Integer word or a 32 bit floating point value.

Endian

The endianness of module is determined by the network type but can be changed from Little Endian to Big Endian or vice versa by using the "Change Order" setting

Little Endian Format or Intel Order

In little endian format, the least significant byte is stored first, followed by the next three more significant bytes. For example a 32bit value of 0x12345678 would be stored in Memory in Little Endian as;

Address + 0	0x78
Address + 1	0x56
Address + 2	0x34
Address + 3	0x12

Big Endian Format or Motorola Order

In big endian format, the most significant byte is stored first, followed by the next three least significant bytes. For example a 32bit value of 0x12345678 would be stored in Memory in Big Endian as;

Address + 0	0x12
Address + 1	0x34
Address + 2	0x56
Address + 3	0x78

OUTPUT

Data from the FB2250 comprises of three (3) 32bit words; Gross Weight, Tare Weight and a 32bit Status word

Gross and Tare weights can be selected as either a 32bit Integer or 32bit floating point word.

The Most significant byte indicates the Weigh Mode "G" for Gross and "N" for Net. The next order byte indicates; "O" Overcapacity, "M" Motion of the last command received. (See INPUT Commands)

The next order byte indicates the weight units; "l" pounds, "k" kilograms, "o" ounces and "g" grams.

The least significant byte indicates the number of decimal places if the weight output is selected to be a 32bit Integer word. If a Floating point word is selected this byte will be 0.

INPUT

Single byte Commands can be sent from the network. Although the input is read as a 32 bit word only the least significant byte is used at this time. When the command is sent and recognized it is entered into the 32 bit status byte in the least significant command byte location. New commands can be transmitted after transmitting a NULL command.

Recognized Commands

Print Stream (see Custom Format PC2250)

Print Format Stream; CR, SPACE, STX, ENQ or defined Poll Character

Tare: "A"

Print Ticket "p" / "P"

Zero "Z"

Change Gross Net Weigh Mode: "G"

Change Units: "U"

Debug

- Data in the Anybus Module can be examined by clicking the **START DEBUG** button.
- It is stopped by clicking the **STOP DEBUG** button.
- The Start Debug and Stop Debug provides a verification of the FB2250 communicating with the fieldbus module by sending hexadecimal values which may be observed upon pressing start and stop debug.
- The **WRITE BUFFER** contains three 32-bit words.
 - **Gross Weight, Tare Weight** and the **Status Word** is the data sent to the Network.
- The Contents of the **READ BUFFER**, which is the data received from the network, is displayed as a 32-bit word.

7.9. 4-20mA

A point-to-point or multi-drop circuit mainly used in the process automation field to transmit signals from instruments in the field to a controller. It sends an analog signal from 4 to 20mA that represents 0 to 100% of the weight displayed at the instrument. As a current loop signal, the FB2250's 4-20ma output is a passive device which requires an **isolated and dedicated** power supply provided by others.

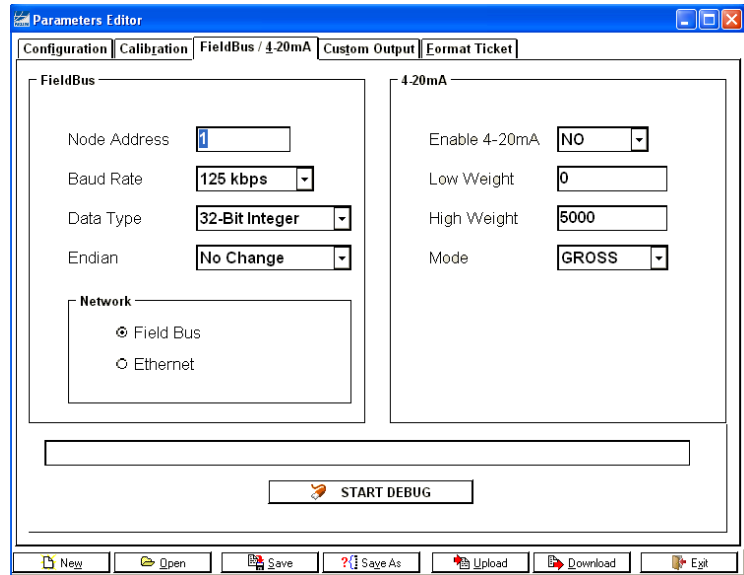

Enable 4-20mA – From the drop-down menu, select YES to enable the output.

Low Weight – Enter the weight value which represents the 4mA output signal.

High Weight – Enter the weight value which represents the 20mA output signal.

Mode – From the drop-down menu, select weight mode which the 4-20mA will track, Gross or Net.

WARNING: Do not physically install the 4-20mA card until the instrument is configured and calibrated (weight) to the platform.

7.10. Custom Output: Settings

Checksum:

This setting determines whether a checksum character is enabled or not enabled. Checksum is an error detection method that checks the integrity of the entire string of data that is transmitted.

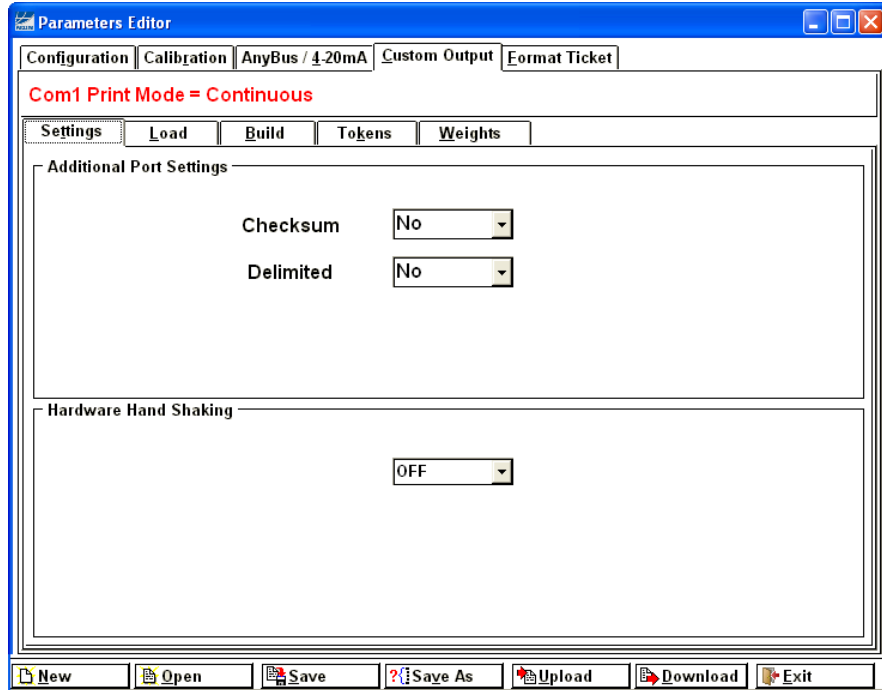

Delimited: This setting determines if a comma is added to the output string to separate data fields contained within the output string.

Hardware handshaking: No function. For future use.

7.11. Custom Output: Load

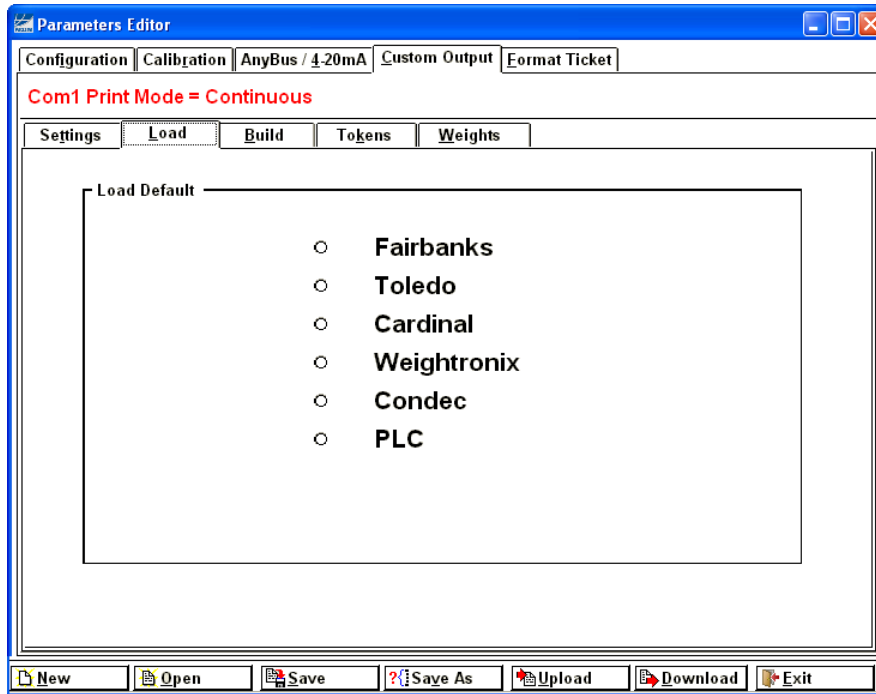

A variety of pre-packaged output strings is available, click the radio button to select.

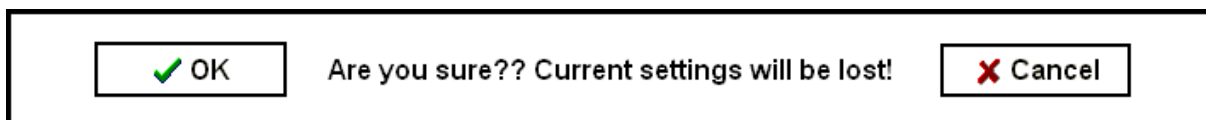

Upon selection, confirm or cancel. Refer to Appendix for data output structures.

NOTE: *PLC is no longer used and not a valid selection.*

NOTE for Rev 1.0 to 1.9: When custom outputs are formatted for Port 1, the FB2250 Port 1 output must be set to **print F**.

IMPORTANT NOTE: Whenever custom outputs are programmed for Port 2, upon completion the power **MUST** be cycled to the FB2250 Instrument in order for them to take effect.

7.12. Custom Output: Build

The data output string can be customized to suit the application requirements.

The current structure of the output string is displayed at the bottom, in order of transmission from left to right.

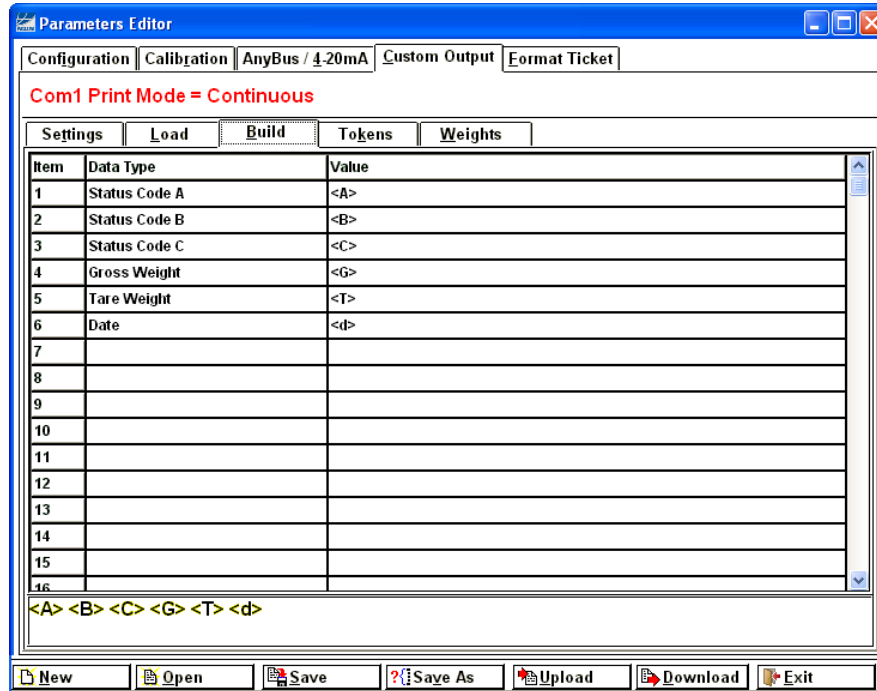

Changing data items is accomplished by right clicking the mouse in the selected "DATA TYPE" field.

This will open a selection window containing many different data items.

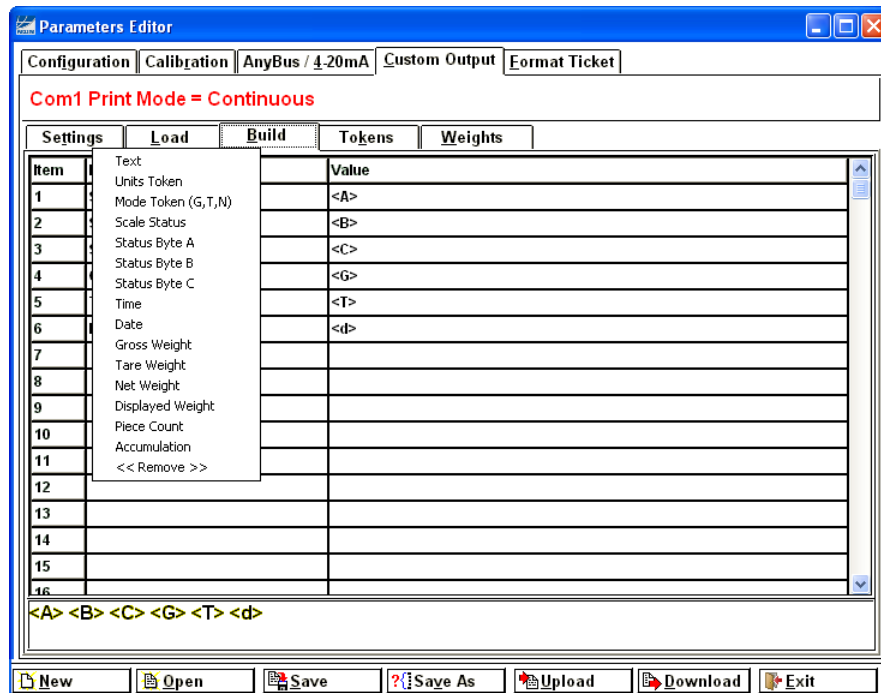

7.13. Custom Output: Tokens

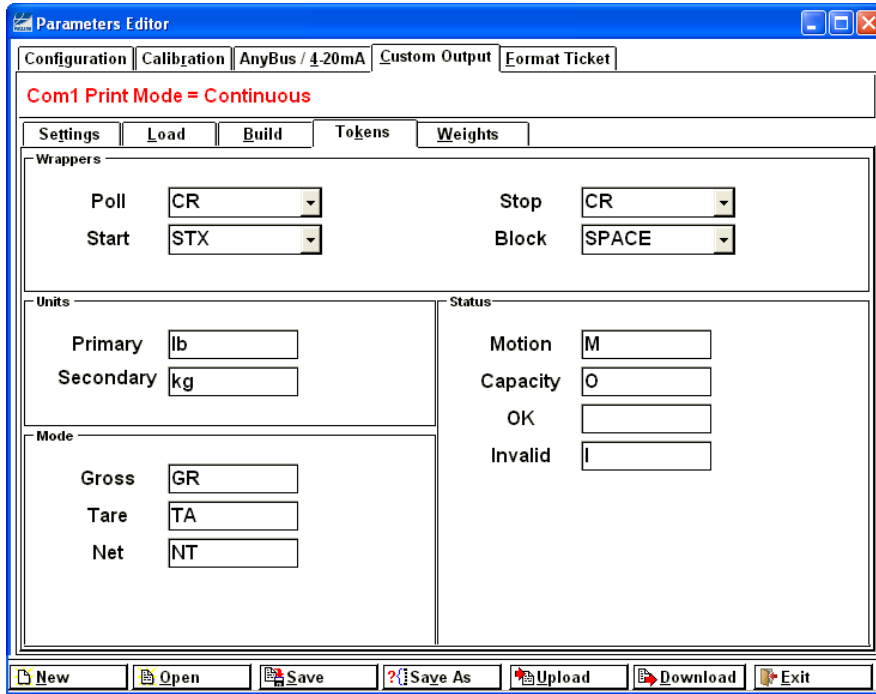

A wide variety of different characters can be selected for the polling character, as well as the start, stop, block, primary and secondary units, weighing mode, motion, and capacity characters.

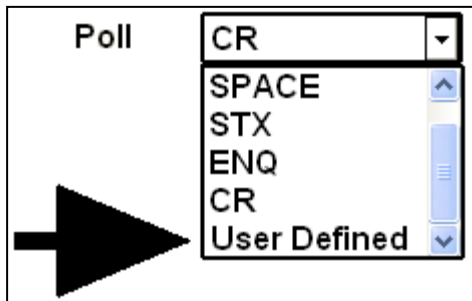

For selection of a character not listed, select "USER DEFINED"

This will produce an additional data entry box as shown.

Selecting data items is accomplished by right clicking the mouse in the additional data entry box.

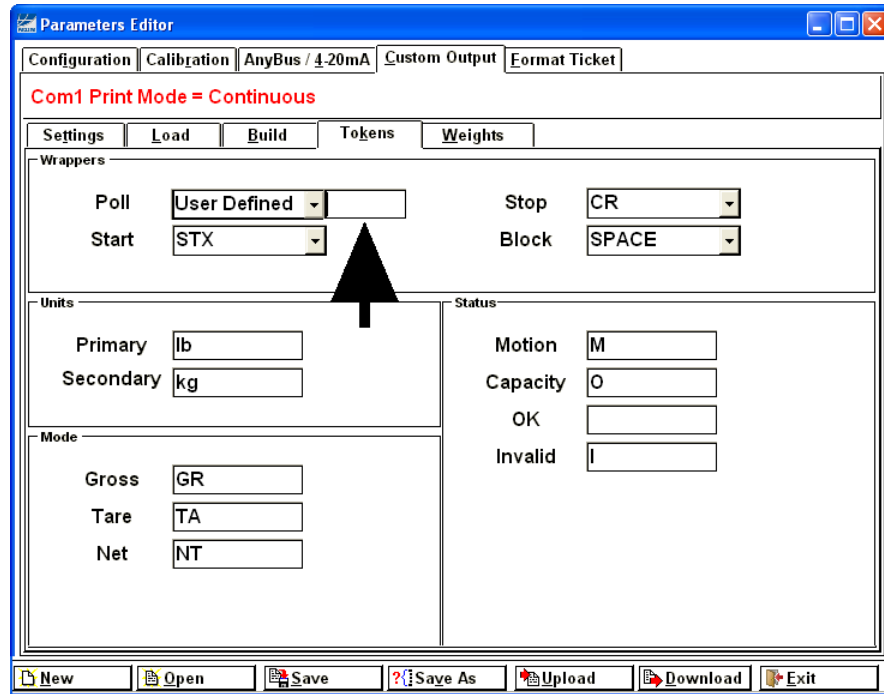

A selection such as <SOH> inserts a Start of Header character... otherwise known as a CTRL/A, or 0x01 HEX

For selection of a character not listed, select "Entry".

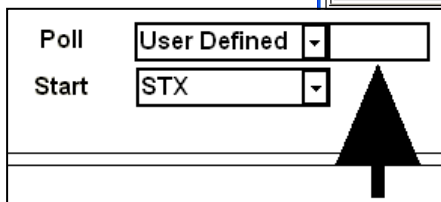
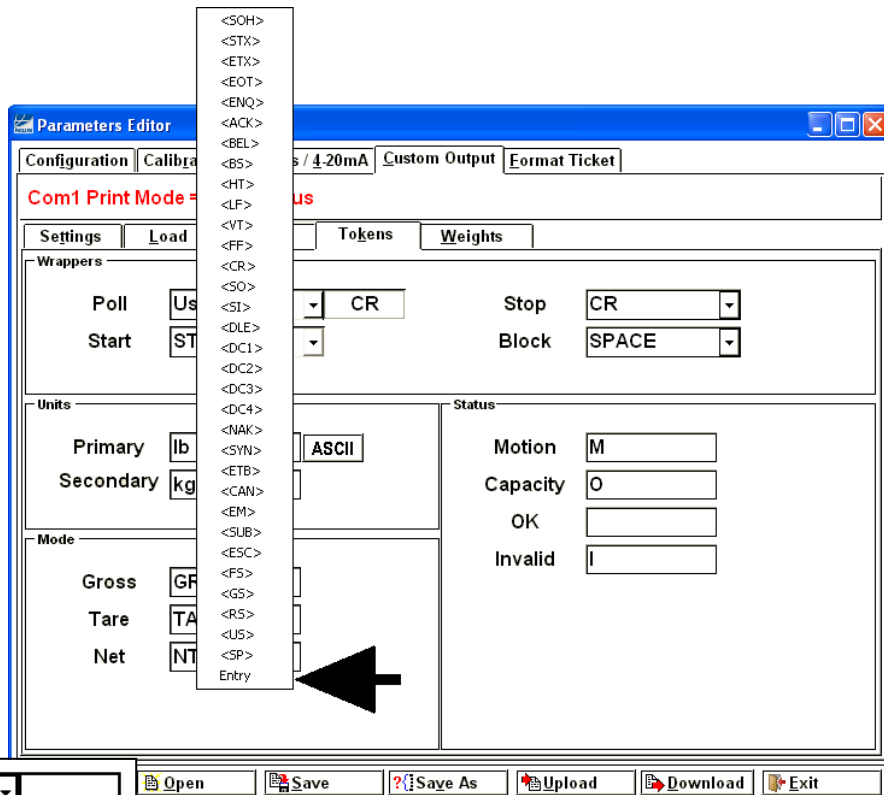

A Selection of Entry allows the user to enter a character using the keyboard, such as an 'A' or a '1'.

7.14. Custom Output: Weights

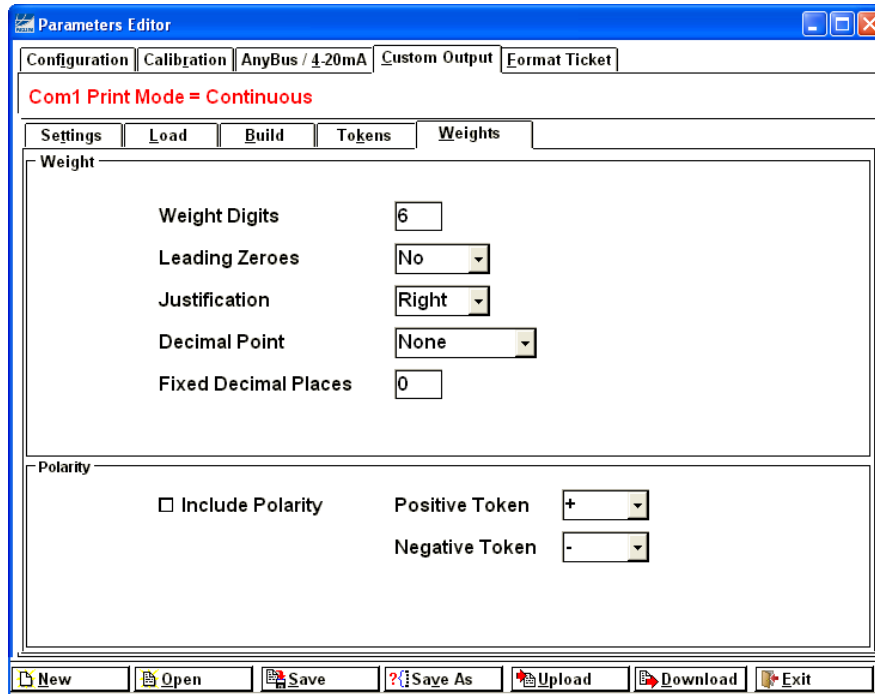

A variety of different settings is also available for the number of weight digits, whether leading zeroes are included or not, left or right justification, decimal point inclusion and type, decimal places, and positive and negative polarity designators.

7.15. Format tickets

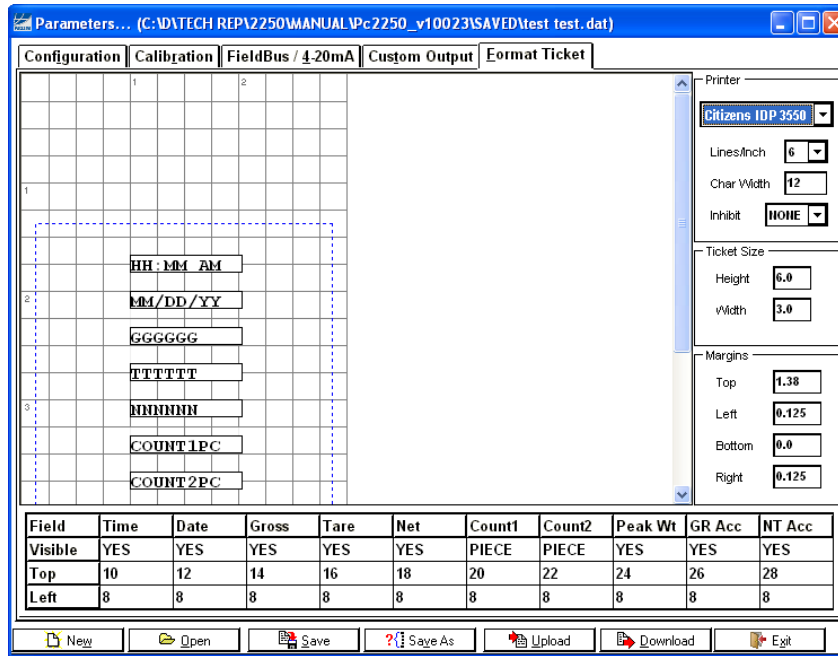

- Formatting tickets is easily performed with this drag and drop interface.
 - The blue-dashes indicate the printable area of the ticket based on the ticket size and margins entered (by the user or by default).
1. Click on the drop down arrow to select the desired ticket **Printer**.
 2. Click on the drop down arrow for **INHIBIT** to select either NONE, HIGH, or LOW.
 3. Enter the **Ticket Size** and **Margins** in inches.
 4. Items can be removed or added from view and printing by right clicking the **VISIBLE** box under the parameter, and then selecting **NO** or **YES**.

- a. Count1 options include:
 - i. NO – not visible
 - ii. PIECE – number of pieces
 - iii. CNT GR. – Gross accumulated count
- b. Count2 options include:
 - i. NO – not visible
 - ii. PIECE – Total accumulated number of pieces
 - iii. CNT NT – NET accumulated count

Field	Time
Visible	YES
Top	6
Left	10

5. Click-and-hold on a data item in the ticket window to move it to a different location or manually change the numeric values for **TOP** and **LEFT**.

NOTES:

- Although the **Lines/ inch** and **Char Width** settings are sent to the printer and stored, they are not being used at this time (possible future use).
- Legends such as **GROSS** cannot be disabled and are **always included**.

7.16. Printed Examples:

ACCUMULATION

Field		Count1	Count2	Peak Wt	GR Acc	NT Acc
Visible		CNT GR	CNT NT	NO	YES	YES
Top		14	16	0	20	22
Left		2	2	0	2	2

* See section [3.5.8. Weight Accumulation](#) (in Operation)

```

4 Items GR
 8333.4 lb GR Total

0 Items NT
 0.0 lb NT Total
    
```

Here you see a sample ticket with 4 gross accumulations stored.

```

0 Items GR
 0.0 lb GR Total

5 Items NT
8333.5 lb NT Total
    
```

Here you see a sample ticket with 5 NET accumulations stored. Note that the Tare weight is not shown.

```

2 Items GR
4166.7 lb GR Total

6 Items NT
9166.8 lb NT Total
    
```

Gross weight and NET weight can be accumulated simultaneously in the FB2250. Each Gross weight stored will be in its own register and each NET weight stored will be in its own register, completely independent from each other.



PIECE COUNT

Field	Time	Date	Gross	Tare	Net	Count1	Count2
Visible	YES	YES	YES	YES	YES	Piece	Piece
Top	2	2	6	8	10	14	16
Left	2	13	7	7	7	7	7

* See section [3.5.14 Piece Counting](#) (in Operation)

Container weighs 5.0 lb.

5 pieces weigh 1.0 lb

Pieces cannot be accumulated.

When **PRINT** key was pressed, 5 pieces were still on the scale.

02:04PM	02-18-14
6.0 lb GR	
5.0 lb TA	
1.0 lb NT	
5 Pieces	
0 Total Pieces	

PIECE COUNT and TOTAL

Field	Time	Date	Gross	Tare	Net	Count1	Count2
Visible	YES	YES	YES	YES	YES	Piece	Piece
Top	2	2	6	8	10	14	16
Left	2	13	7	7	7	7	7

* See section [3.5.15. Piece Count and Total](#) (in Operation)

Container weighs 5.0 lb.

5 pieces weigh 1.0 lb

13 pieces have been accumulated previously before step 10 has been completed.

After step 10 was completed and when **PRINT** key was pressed, 5 pieces were still on the scale.

02:04PM	02-18-14
6.0 lb GR	
5.0 lb TA	
1.0 lb NT	
5 Pieces	
18 Total Pieces	

PEAK WEIGHT

Field	Time	Date	Gross	Tare	Net	Count1	Count2	Peak Wt
Visible	YES	YES	YES	YES	YES	NO	NO	YES
Top	2	2	6	8	10	0	0	14
Left	2	13	7	7	7	0	0	2

* See Section [3.5.16. Peak Weight](#) (in Operation)

Container weighs 5.0 lb

Item(s) in container weighs 11.0 lb

The peak weight applied to the scale to date was 18.0lb Gross weight and occurred on 02-17-14 @ 01:04PM

02:04PM	02-18-14
16.0 lb GR	
5.0 lb TA	
11.0 lb NT	
18.0 lb Peak Weight	
02-17-14 01:04PM	

APPENDIX I: DATA OUTPUT FORMATS

A. General Notes

- <CR> = means carriage return character
- <LF> = line feed character
- <SP> = space character
- <EOT> = end of transmission character
- <...> = used to indicate individual characters for clarity only (not present in data stream)

Power must be cycled after each output download otherwise the FB2250 will not save the downloaded data and will default to the previous setting.

B. Fairbanks/ Toledo Continuous Output

<STX><A><C><WWWWW><TTTTTT><CR>

- A = Status Word A
- B = Status Word B
- C = Status Word C
- W = Displayed Weight
- T = Tare Weight

Leading zeroes are not suppressed. The Continuous Computer Output is an uninitiated, unrequested output that is transmitted at a fixed time interval.

B. Fairbanks/ Toledo Continuous Output, Continued

Character String	Description
STX	Start of Text character : (02 Hex)
A	Status Word A
B	Status Word B
C	Status Word C
xxxxxx	Displayed Weight : x = Weight (6 characters if grad size does not have a decimal point.) (5 characters if the grad size does have a decimal point. The decimal point is not sent as part of the character string.
xxxxxx	Tare Value : x = Tare (6 characters if the grad size does not have a decimal point.) (5 characters if the grad size does have a decimal point. The decimal point is not sent as part of the character string
CR	Carriage Return Character : (0D hex)
CS	Checksum Character : If enabled, this character consists of the last eight bits of the binary sum of all characters transmitted up to this checksum character.

Status Word A

Bit #	Decimal Point or Zero Location							
	x00	x0	x	x.x	x.xx	x.xxx	x.xxxx	x.xxxxx
0	0	1	0	1	0	1	0	1
1	0	0	1	1	0	0	1	1
2	0	0	0	0	1	1	1	1
	Increment Size							
	Count by 1			Count by 2			Count by 5	
3	1			0			1	
4	0			1			1	
5				Always Logic 1				
6				Always Logic 0				
7				Parity Bit				



B. Fairbanks/ Toledo Continuous Output, Continued

Status Word B

Bit #		Description
0	Gross = 0	Net = 1
1	Positive = 0	Negative = 1
2	In Range = 0	Overcapacity = 1
3	No Motion = 0	Motion = 1
4	lb = 0	kg = 1
5	Always Logic 1	
6	Normal = 0	Power Up = 1
7	Parity Bit	

Status Word C

Bit #		Description
0	Always Logic 0	
1	Always Logic 0	
2	Always Logic 0	
3	Normal = 0	Print Switch Pushed = 1
4	Always Logic 0	
5	Always Logic 1	
6	Normal = 0	Keyboard Tare = 1
7	Parity Bit	

B. Cardinal 738 Continuous Scoreboard Output

<CR><P><WWWWW><m><SP><U><SP><g><SPSP><ETX>

W = Displayed weight

P = Polarity + = Positive weight
 - = Negative weight

U = Units

lb = pounds

kg = kilograms

m = Motion or o = Overload

g = Gross; n = Net

SP = Space

Leading zeroes are not suppressed

C. Weightronics WI-120 Continuous Output

<G><P><WWWWW><SP><U><CR><LF>

G = Gross; N = Net

P = Polarity + = positive weight
 - = negative weight

U = Units

lb = pounds

kg = kilograms

SP = Space

Leading zeroes are not suppressed

D. Condec Continuous Output

<STX><P><WWWWWW><U><G><M><CR>

P = Polarity space = positive weight
 - = negative weight

W = Displayed weight

U = Units

L = pounds

K = kilograms

G = Gross; N = Net

M = Motion

Leading zeroes are suppressed

E. Demand Output - Default

Activated by the receipt of a **<CR>**.

Gross Weight – No Motion – decimal points included

**<SP> <W> <W> <W> <W> <W> <W> <SP> <|> <SP> <SP> <G>
<R> <SP> <SP> <CR> <LF> <EOT>**

Gross Weight – Motion – decimal points included

**<SP> <W> <W> <W> <W> <W> <W> <SP> <|> <SP> <SP> <g>
<r> <SP> <SP> <CR> <LF> <EOT>**

Net Weight – No Motion – decimal points included

**<SP> <W> <W> <W> <W> <W> <W> <SP> <|> <SP> <SP> <N>
<T> <SP> <SP> <CR> <LF> <EOT>**

F. Continuous Output - Default

Outputs once every display update rate cycle.

Continuous Output formatted output. **Same for Poll and Auto**

Gross Weight – No Motion – decimal points included

```
<SP> <W> <W> <W> <W> <W> <W> <SP> <|> <b> <SP> <SP> <G>
<R> <SP> <SP> <CR> <LF> <EOT>
```

Gross Weight – Motion – decimal points included

```
<SP> <W> <W> <W> <W> <W> <W> <SP> <|> <b> <SP> <SP> <g>
<r> <SP> <SP> <CR> <LF> <EOT>
```

Net Weight – No Motion – decimal points included

```
<SP> <W> <W> <W> <W> <W> <W> <SP> <|> <b> <SP> <SP> <N>
<T> <SP> <SP> <CR> <LF> <EOT>
```

Net Weight – Motion – decimal points included

```
<SP> <W> <W> <W> <W> <W> <W> <SP> <|> <b> <SP> <SP> <n>
<t> <SP> <SP> <CR> <LF> <EOT>
```

G. PLC (Do not use.)

The PLC selection is no longer functional within the PC2250 software and should not be used or selected.

General Information

The information below is automatically configured by the FB2250 and is provided as supplemental information only.

Continuous Output, transmitting data on every other A/D update

— Approximately 32 transmissions per second.

Baud Rate	19,200
Data Bits	8
Parity	None
Stop Bit	1
Mode	Continuous

The output string is **12 characters**, seen as “**wwwwwwuumm<eot>**” where,

<wwwwww> = Weight including decimal point and negative sign.

Negative sign precedes most significant digit and may be preceded by space characters.

<uu> = units “lb”, “kg”, “oz”, or “g “. “oz” may indicate ounces, or lb/ounces.

<mm> = mode “GR” or “NT” for stable weight, or “gr” or “nt” for motion.

<eot> = end of text.

Example 1: **Gross – lbs. – Weight Stable**

<WWWWWWW> <l> <G> <R> <EOT>

Example 2: **Gross – lbs. – Weight in Motion**

<WWWWWWW> <l> <g> <r><EOT>

Example 3: **Net – kgs. – Weight Stable**

<WWWWWWW> <k> <g> <N> <T> <EOT>

Example 4: **Net – kgs. – Weight in Motion**

<WWWWWWW> <k> <g> <n> <t> <EOT>

NOTE: Once **FIELD BUS OPTIONS** have been programmed, the installing technician’s setup is complete.

Specialized tools available from: <https://www.anybus.com/support/file-doc-downloads/anybus-compactcom-30-series>

Interface of the **HMS COMMUNICATIONS** device, power supply to same device, and programming of the PLC is strictly the responsibility of the customer.

H. UPS

- **Serial Data Output Format** for **UPS Worldship Software**.

The instrument will transmit the following string of data.

Character Number **1 2 3 4 5 6 7 8 9 10 11 12 13 14 15 16 17 18**

String 1

Gross Weight: X X X X . X X SP l/k b/g SP G/g R/r SP SP CR LF EOT

NOTES:

- Characters denoted by “**X**” are characters **0-9**.
 - Leading zeroes are replaced with spaces (**SP**).
 - **Character 5** is a decimal point (**HEX 2E**).
 - Lower case “**l**” and “**b**” for **Avoirdupois Units**, or “**k**” and “**g**” for **Metrics Units**.
 - The first weight character will be a **minus (-)**, **HEX 2D**, If weight is negative.
 - Characters separated with a “**/**” denoted one of the characters will be transmitted.
 - Lower case **gr** in **characters 12 and 13** indicates scale motion.
 - Upper case indicates stable weight.
 - **EOT, HEX 04** is transmitted in “**HiCAP**” condition.
 - Transmission will occur when a **CR (Hex 0D)** carriage return is received.
-

I. P Ship

- Serial Data Output Format for P Ship, used to interface to FedEx Shipping Programs.

All computer commands and scale responses are **ASCII Character Strings**, where:

<CR> is an ASCII carriage return (hexadecimal 0D)

<LF> is an ASCII line feed (hexadecimal 0A)

<ETX> is an ASCII End-Of-Text (hexadecimal 03)

(STATUS) is a two ASCII number representation of the scale status (in the form of hexadecimal 3x3x, where the bit pattern of the low nibbles, indicated by an "x", determine the actual status conditions)

COMPUTER RESPONSE	SCALE RESPONSE	COMMAND RESULT
W<CR>	<LF><SP>XXX.XXUU<CR>(STATUS)<ETX>	Returns the weight and scale status in two ASCII digits.
S<CR>	<LF>S(STATUS)<CR><ETX>	Returns the scale Status in two ASCII digits (defined in the following section)
Z<CR>	No response	Zeroes the scale
All Else	<LF>?<CR>	Unrecognizable command

Notes: In the scale response to "W<CR>":

- XXX.XX** = A five digit number with two digits to the right of the decimal point which is the displayed scale weight.
- SP** = An ASCII space (hexadecimal 20). In the event of a negative weight, an ASCII, "-" (hexadecimal 2D) is returned in this location.

I. P Ship, Continued

3. **UU =** A two character weight identifier. If the scale is configured to weigh kilograms, a "KG" (uppercase letters) will be returned, if configured for pounds, "LB" (uppercase letters) will be returned.

4. The decimal point is returned by the scale as part of the ASCII string.

5. Interpretation of scale status digits

The high order nibble of each status byte has a value of 3 (0011 B). The low order nibble of the first and second bytes are defined as follows:

1st Byte: Bit 0 - High = scale is in motion
 Low = scale is stable
 Bit 1 - High = scale at zero
 Low = scale not at zero
 Bit 2 - Low = not used
 Bit 3 - Low = not used

2nd Byte: Bit 0 - High = scale is below zero
 Low = scale is not below zero
 Bit 1 - High = scale is over capacity
 Low = scale is not over capacity
 Bit 2 - High = scale ROM program failure
 Low = scale ROM okay
 Bit 3 - High = faulty calibration data*
 Low = scale calibration okay

*This is the result of an incorrect checksum

An example of the scale response to an "S" command would be:

<LF>S20<CR><ETX>

The following status conditions are in effect for this response:

- scale at zero
- scale is not below zero
- scale is not over capacity
- scale ROM okay
- scale calibration okay

APPENDIX II: ASCII CHART

Char	Dec	Hex
NUL	0	0
SOH	1	1
STX	2	2
ETX	3	3
EOT	4	4
ENQ	5	5
ACK	6	6
BEL	7	7
BS	8	8
HT	9	9
LF	10	a
VT	11	b
FF	12	c
CR	13	d
SO	14	e
SI	15	f
DLE	16	10
DC1	17	11
DC2	18	12
DC3	19	13
DC4	20	14
NAK	21	15
SYN	22	16
ETB	23	17
CAN	24	17
EM	25	19
SUB	26	1a
ESC	27	1b
FS	28	1c
GS	29	1d
RS	30	1e
US	31	1f
SP	32	20

Char	Dec	Hex
!	33	21
"	34	22
#	35	23
\$	36	24
%	37	25
&	38	26
`	39	27
(40	28
)	41	29
*	42	2a
+	43	2b
,	44	2c
-	45	2d
.	46	2e
/	47	2f
0	48	30
1	49	31
2	50	32
3	51	33
4	52	34
5	53	35
6	54	36
7	55	37
8	56	38
9	57	39
:	58	3a
;	59	3b
<	60	3c
=	61	3d
	62	3e
?	63	3f
@	64	40
A	65	41

Char	Dec	Hex
B	66	42
C	67	43
D	68	44
E	69	45
F	70	46
G	71	47
H	72	48
I	73	49
J	74	4a
K	75	4b
L	76	4c
M	77	4d
N	78	4e
O	79	4f
P	80	50
Q	81	51
R	82	52
S	83	53
T	84	54
U	85	55
V	86	56
W	87	57
X	88	58
Y	89	59
Z	90	5a
[91	5b
\	92	5c
]	93	5d
^	94	5e
_	95	5f
a	96	60
b	97	61
	98	62

Char	Dec	Hex
c	99	63
d	100	64
e	101	65
f	102	66
g	103	67
h	104	68
i	105	69
j	106	6a
k	107	6b
l	108	6c
m	109	6d
n	110	6e
o	111	6f
p	112	70
q	113	71
r	114	72
s	115	73
t	116	74
u	117	75
v	118	76
w	119	77
x	120	78
y	121	79
z	122	7a
{	123	7b
	124	7c
}	125	7d
~	126	7e
DEL	127	7f

APPENDIX III: FB2250 REMOTE DISPLAY WIRING

RS232 INTERFACE WIRING (Master)

FB2250/55 REMOTE DISPLAY

FB2250* REMOTE DISPLAY

MODEL	COM	CONNECT		COM	CONNECT		COM	CONNECT	
FB2200 (ABS)	1	3	TX	1	TB4(A)-1	RX	1	TB4-1	RX
	1	5	GND	1	TB4(A)-4	GND	1	TB4-4	GND
FB2200 (SS)	1	3	TX	1	TB4(A)-1	RX	1	TB4-1	RX
	1	5	GND	1	TB4(A)-4	GND	1	TB4-4	GND
FB2255 or FB2250	1	TB4(A)-2	TX	1	TB4(A)-1	RX	1	TB4-1	RX
	1	TB4(A)-1	RX	1	TB4(A)-2	TX	1	TB4-2	TX
	1	TB4(A)-4	GND	1	TB4(A)-4	GND	1	TB4-4	GND
	2	TB4(B)-2	TX	1	TB4(A)-1	RX	1	TB4-1	RX
	2	TB4(B)-1	RX	1	TB4(A)-2	TX	1	TB4-2	TX
	2	TB4(B)-4	GND	1	TB4(A)-4	GND	1	TB4-4	GND
FB2250*	1	TB4-2	TX	1	TB4(A)-1	RX	1	TB4-1	RX
	1	TB4-1	RX	1	TB4(A)-2	TX	1	TB4-2	TX
	1	TB4-4	GND	1	TB4(A)-4	GND	1	TB4-4	GND
	2	TB4-7	TX	1	TB4(A)-1	RX	1	TB4-1	RX
	2	TB4-6	RX	1	TB4(A)-2	TX	1	TB4-2	TX
	2	TB4-9	GND	1	TB4(A)-4	GND	1	TB4-4	GND
2300	1	TB4-1	TX	1	TB4(A)-1	RX	1	TB4-1	RX
	1	TB4-2	GND	1	TB4(A)-4	GND	1	TB4-4	GND
2500	2, 3, 4 or 5	3	TX	1	TB4(A)-1	RX	1	TB4-1	RX
		5	GND	1	TB4(A)-4	GND	1	TB4-4	GND
2500 (SS)	2, 3, 4 or 5	4	TX	1	TB4(A)-1	RX	1	TB4-1	RX
		8	GND	1	TB4(A)-4	GND	1	TB4-4	GND
2800	A	TB3-2	TX	1	TB4(A)-1	RX	1	TB4-1	RX
		TB3-4	GND	1	TB4(A)-4	GND	1	TB4-4	GND
	B	TB2-2	TX	1	TB4(A)-1	RX	1	TB4-1	RX
		TB2-4	GND	1	TB4(A)-4	GND	1	TB4-4	GND
5200A	1 or 2	4	TX	1	TB4(A)-1	RX	1	TB4-1	RX
		5	RX	1	TB4(A)-2	TX	1	TB4-2	TX
		8	GND	1	TB4(A)-4	GND	1	TB4-4	GND

* Old style with 28600 Main PCB.

APPENDIX IV: REMOTE DISPLAY ACTIVE KEYS

INSTRUMENT	FB2250 ACTIVE FRONT PANEL KEYS
FB2200	No Active Keys
FB2250	Units, Zero, Gross Net, Auto Tare, Print *
FB2255	Units, Zero, Gross Net, Auto Tare, Print *
2300	No Active Keys
2500 / FB2550	No Active Keys
2800	No Active Keys
5200A	Units, Gross Net

* The “master” FB225X must have the printer on COM 1 and COM 1 must be configured for **Button**. COM 2 of the “master FB225X must be configured for **Poll** and the FB225X acting as the remote display must be connected to COM 2 of the “master”.

APPENDIX V: REMOTE PC COMMANDS

Transmitting certain ASCII characters to the FB2250 will duplicate a key-press from a remote location via the RS 232 serial connection to Port 1. The baud rate, parity, and stop bits must match. The data bit length is 8 bits.

ASCII CHARACTER	FUNCTION PERFORMED / COMMENTS
Z (upper case)	Zero. Active in the Polled or Button Modes
A (upper case)	Tare (Auto Tare). Active in the Polled or Button Modes
U (upper case)	Change Units. Active in the Polled or Button Modes
g (lower case)	Toggle Gross / Net. Active in the Polled or Button Modes
P or p (either case)	'P' or 'p". Active in the Polled or Button Modes The output will be the same as if the instrument front panel switch is operated. This output is formatted via the PC2250 program, using the 'Format Ticket' tab and can include any of the field items and in the order prescribed.
CR (upper case)	Carriage Return. Active in the Polled Mode Output will be the displayed weight, either Net or Gross. If Motion then "GR" and "NT" are transmitted as "gr" and "nt". Both strings are terminated with; Carriage Return, Line Feed, End Of Transmission, <CR><LF><EOT>

APPENDIX VI: FB2250 PANEL MOUNT DIMENSIONS

Panel Mount cutout dimensions are 11.0" x 9.0" x 3.25" minimum.

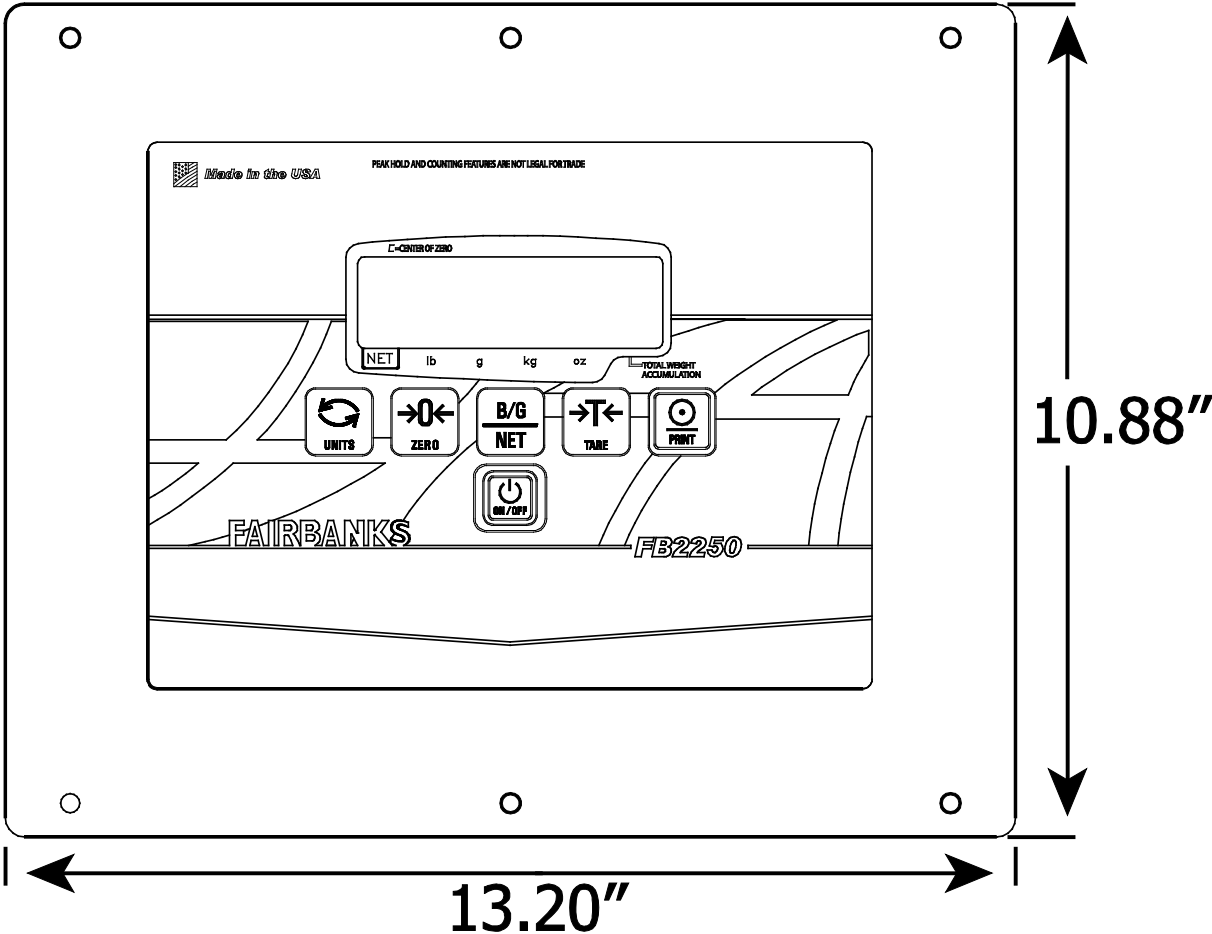



Manufactured by Fairbanks Scales Inc.

www.fairbanks.com

FB2250 Series Instrument

**FB2250 / PC 2250
Document 51214**



FB2550 Series Instrument

In/Out Application

Network Application



Amendment Record

FB2550 Series Instrument Service Manual, 51254

Manufactured by Fairbanks Scales Inc.
821 Locust
Kansas City, Missouri 64106

Created	10/2010	
Revision 1	5/2011	Released document.
Revision 2	4/2012	Updated manual to Rev. 3.x Software. Added numerous feature definitions, specifications and installation information
Revision 3	7/2012	Added Network Application information and update images.
Revision 4	9/2014	Numerous programming updates, printer replacement, revised many Instrument descriptions and images to match upgrades.
Revision 5	2/2015	Added Appendix V
Revision 6	1/2016	Service & Maintenance > Input Data correction
Revision 7	6/2016	Updated Input / Output chapter > Updated TM220 printer
Revision 8	02/2017	Moved Fieldbus information to Appendix I, Updated Condec output



Disclaimer

Every effort has been made to provide complete and accurate information in this manual. However, although this manual may include a specifically identified warranty notice for the product, Fairbanks Scales makes no representations or warranties with respect to the contents of this manual, and reserves the right to make changes to this manual without notice when and as improvements are made.

It is the responsibility of the requesting party to develop, maintain, install, and connect networking devices and general network connectivity as it applies to the originating party's network. No warranty or guarantee, expressed or implied, concerning the network, its design, its installation, or operational characteristics has been offered by Fairbanks Scales. Fairbanks Scales shall not be liable for any loss, damage, cost of repairs, incidental or consequential damages of any kind, whether or not based on express or implied warranty, contract, negligence, or strict liability arising in connection with the design, development, installation, or use of an intended network.

Trademarks

Award is a trademark of Award Software International, Inc.

CF and Compact Flash are trademarks of ScanDisk Corporation.

Microsoft, Microsoft Windows XP Pro, Windows XP Pro Embedded, and MS-DOS are either trademarks or registered trademarks of Microsoft Corporation.

Adobe, the Adobe logo, Acrobat, the Adobe PDF logo, Distiller, and Reader are either registered trademarks or trademarks of Adobe Systems Incorporated.

All other product names mentioned herein are used for identification purpose only and may be trademarks and/or registered trademarks of their respective companies.

© Copyright 2010-2017

This document contains proprietary information protected by copyright. All rights are reserved; no part of this manual may be reproduced, copied, translated, or transmitted in any form or by any means without prior written permission of the manufacturer.

Table of Contents

SECTION 1: GENERAL INFORMATION	10
1.1. Introduction	10
1.1.1. <i>FB2550 Standard Features</i>	11
1.1.2. <i>Internal Instrument Components</i>	11
1.1.3. <i>Two Interface Types</i>	11
1.1.4. <i>External Scale Components</i>	11
1.1.5. <i>Scale Components</i>	12
1.2. Specifications	13
1.3. What is Intalogix Technology?	14
SECTION 2: COMPANY SERVICE INFORMATION	10
2.1. General Service Policy	10
2.2. Users' Responsibilities	11
SECTION 3: SECURITY, LOGINS & PASSWORDS	10
3.1 Levels of Security	10
3.2. Login	11
3.3. Reports Login	12
3.4. Changing Passwords	13
3.4.1. <i>Write Customer Password</i>	13
3.4.2. <i>Write Remote Customer Password</i>	14
SECTION 4: STANDARD USER OPERATIONS	19
4.1. Introduction	19
4.1.1. <i>Keypad Functions</i>	19
4.1.2. <i>External Keyboard Functions</i>	20
4.2. Weighing Operations	21
4.2.1. <i>Unloaded Scale Functions</i>	21
4.2.2. <i>Inbound/Outbound Weighing</i>	22
4.2.3. <i>Gross Weighing</i>	23
4.2.4. <i>Gross/Tare/Net Weighing</i>	24
4.3. Operator Menu Programming	25
4.3.1. <i>Time and Date Format</i>	25
4.3.2. <i>Time and Date</i>	26
4.3.3. <i>Ticket Number</i>	26
4.3.4. <i>Load Cell Diagnostics</i>	27
4.4. Proper Shutdown Procedure	28
SECTION 5: AUDIT TRAIL	29
5.1. Login	29
5.2. Calibration Audit Trail	29
5.3. Configuration Audit Trail	29
SECTION 6: PROGRAMMING	30
6 .1. Introduction	30
6.2. Shortcut Keys	31



- 6.3. Customized Instrument Configurations..... 32
- 6.4. Programmable Legends 32
- 6.5. Programmable Prompts 33
- 6.6. Entry Sequence Prompts 34
- 6.7. Vehicle Image Type 35
- 6.8. Threshold Weights 36
- 6.9. On Scale Alarm..... 37
- 6.10. Blind Counter 38
- SECTION 7: SUPERVISOR PROGRAMMING..... 39**
- 7.1. Introduction..... 39
- 7.2. Operator Menu 40
 - 7.2.1. Entering a New Tare Automatically..... 40
 - 7.2.2. Entering a New Keyboard Tare..... 41
 - 7.2.3. Resetting the Ticket Number 41
- 7.3. Configuration Menu 42
 - 7.3.1. Edit Customers..... 42
 - 7.3.2. Edit Products..... 43
 - 7.3.3. Edit Product Groups 46
 - 7.3.4. Edit Tares..... 48
 - 7.3.5. Edit Tags..... 49
 - 7.3.6. Deleting Incomplete Transactions..... 50
 - 7.3.7. Clear Totals..... 51
- 7.4. Reports 51
 - 7.4.1. Master File Reports 52
 - 7.4.2. Transaction Reports 54
 - 7.4.3. Summary Reports..... 58
 - 7.4.4. Email Transaction..... 60
 - 7.4.5. Scale Summary Audit Report..... 61
- SECTION 8: INPUT/ OUTPUT 63**
- 8.1. Printers..... 63
 - 8.1.1. Printer Switch Settings..... 63
 - 8.1.2. iDP3550 Tape Printer 64
 - 8.1.3. TM-U220 Tape Printer 65
 - 8.1.4. SP700 Tape Printer 67
 - 8.1.5. OKI ML420 Report Printer 69
 - 8.1.6. XEROX® Phaser 3040 Report Printer 73
 - 8.1.7. TM-U590 Ticket Printer..... 75
 - 8.1.8. TM-U295 Ticket Printer..... 76
 - 8.1.9. SP298 Ticket Printer..... 77
 - 8.1.10. SP2000 Ticket Printer..... 79
 - 8.1.11. SP2200 Ticket Printer..... 79
 - 8.1.12. Programming the Printers 80
 - 8.1.13. Serial Printer Programming..... 81
 - 8.1.14. USB Printer Programming 83
- 8.2. Format Tickets 85
- 8.3. Web Ticket Layout 89
 - 8.3.1. Overview..... 89
 - 8.3.2. Programming a Web Ticket..... 89
- 8.4. Serial Card 95
- 8.5. Serial 20mA Interfaces 96
 - 8.5.1. Multi-Function Board..... 96



- 8.5.2. Serial Expansion Board 99
- 8.6. Configure Outputs 100**
 - 8.6.1. Configuring an Output Data String 100
 - 8.6.2. Two Methods of Formatting 100
 - 8.6.3. Method 1 – Preconfigured Output 101
 - 8.6.4. Method 2 – Customizing Data Output Strings 104
 - 8.6.5. Configuring a COM Port for Scale Summing 110
- 8.7. IP Output Configuration 111**
- 8.8. RS-485 Configuration 112**
- 8.9. Network Parameters Configuration 113**
- 8.10. Fieldbus Protocols and Formats 115**
 - 8.10.1. Transmission Methods 115
 - 8.10.2. Communication Format 115
 - 8.10.3. Handling Network Traffic 115
- SECTION 9: ACCESSORIES 130**
 - 9.1. Accessory Parts List 130**
 - 9.1.1. Printers and Accessories 130
 - 9.1.2. Additional Accessories 131
 - 9.2. Programming the Traffic Light Control 132**
 - 9.3. Video Camera Programming 136**
 - 9.4. External Display [Dual Cloning] 138**
 - 9.4.1. Standard Setup 138
 - 9.4.2. Display Settings Defaults 139
 - 9.4.3. Disabling the External Display 140
 - 9.4.4. Restoring the Display with an External Keyboard 141
- SECTION 10: SERVICE & MAINTENANCE 130**
 - 10.1. Database Maintenance 130**
 - 10.1.1. Database Backup 130
 - 10.1.2. Database Restore 136
 - 10.1.3. Re-Index Database 139
 - 10.1.4. Transaction Data Backup Days Reminder 139
 - 10.1.5. Completed TXN IMGs 140
 - 10.2. Printer Troubleshooting 141**
- APPENDIX I: FIELDBUS REFERENCE 156**
 - A. Overview 156
 - B. DeviceNet (30923) 157
 - C. ControlNet (30924) 159
 - D. Modbus RTU (30925) 161
 - E. Modbus-TCP Interface Kit (32760) 162
 - F. ProfiBus-DP (30922) 163
 - G. EtherNet/IP (31974) 165
 - H. Fieldbus Protocols and Formats 166
 - I. DT7000 Gateway 167
 - J. Standard DT7000 Fieldbus Configuration 175
 - K. Fieldbus Data Representation 177
- APPENDIX II: DATA OUTPUT 156**
 - A. Remote Display Output 156**
 - B. Configure Output 156**
 - C. SMA PROTOCOL 160**



D. EXAMPLES 162

APPENDIX III: 20MA CODES 163

APPENDIX IV: TICKET DATA FIELDS..... 165

APPENDIX V: REMOTE FUNCTION COMMANDS..... 167

APPENDIX VI: FIELDBUS REFERENCE..... 168

 A. *Always Update, Yes*..... 185

 B. *Filter Off*..... 185

 C. *Expansion Filtering, Disabled*..... 185

SECTION 1: GENERAL INFORMATION

1.1. Introduction

The **FB2550** is a modular designed Instrument, configurable and upgradable using **Printed Circuit Modules**.

- Each module provides a specific scale or I/O functionality to the weighing system.
- The FB2550 Instrument has four enclosure styles.
 - *DESKTOP* – *PANEL MOUNT* – *RACK MOUNT* – *NEMA 4 MODEL*
- A seven-inch (7”) color graphic display with touchscreen operation and easy-to-understand prompts.
- The FB2550 Instrument is designed to function with **Intalogix® Technology**, Analog Load Cells, or Mettler Toledo DigiToI® Load Cells.
- An integrated e-mail client is configurable to alert a service organization or individual of a problem prior to total failure.
 - These error notifications include such warnings as load cell failure, and calibration changes.
 - Several other notifications are available inform the proper individuals of the scale’s operating condition. This system uses the customer’s existing email infrastructures.
 - Requires a connection to the customer’s PC Network.
- The Instrument provides many connectivity and data acquisition capabilities with the following protocol types.
 - *RS232* – *RS422 SERIAL PORTS* – *USB* – *PCI 10/100 MBS ETHERNET INTERFACE*



The Desktop FB2550 Instrument has three (3) fully programmable RS-232 DB9 Serial COM Ports, three (3) USB Ports, a VGA and an Ethernet Port.

1.1.1. FB2550 Standard Features

- 7" full-color display
- Ethernet
- SQL database
- Touch screen operation
- Integrated web server
- Multiple/ Expandable serial ports
- Built-in reporting functions
- IP camera interface with onscreen image
- Stainless steel construction
- Programmable F-key prompts

1.1.2. Internal Instrument Components

- Single Board Computer (SBC)
- Flash Module
- Multi-Function Board
- Expansion Board
- Expansion Modules
- Power Supply
- 7" Display, WVGA LED
- Intalogix Communications Board
- Accessory 789

NOTE: Any combination of up to **seven (7) Interface Modules** can be installed. This number could be less, depending on the module kit type.

1.1.3. Two Interface Types

The **FB2550** interfaces to a single scale using one of two different types of technology hardware interfaces.

- Intalogix® Technology
- Analog Technology

1.1.4. External Scale Components

PART NO.	DESCRIPTION	MAX PER INSTRUMENT
33476	External Intalogix® Interface	7
31281	Dual External Intalogix® Interface	7
31282	External Analog Interface	7
31283	Dual External Analog Interface	4
31284	External QMB Interface	7

1.1.5. Scale Components

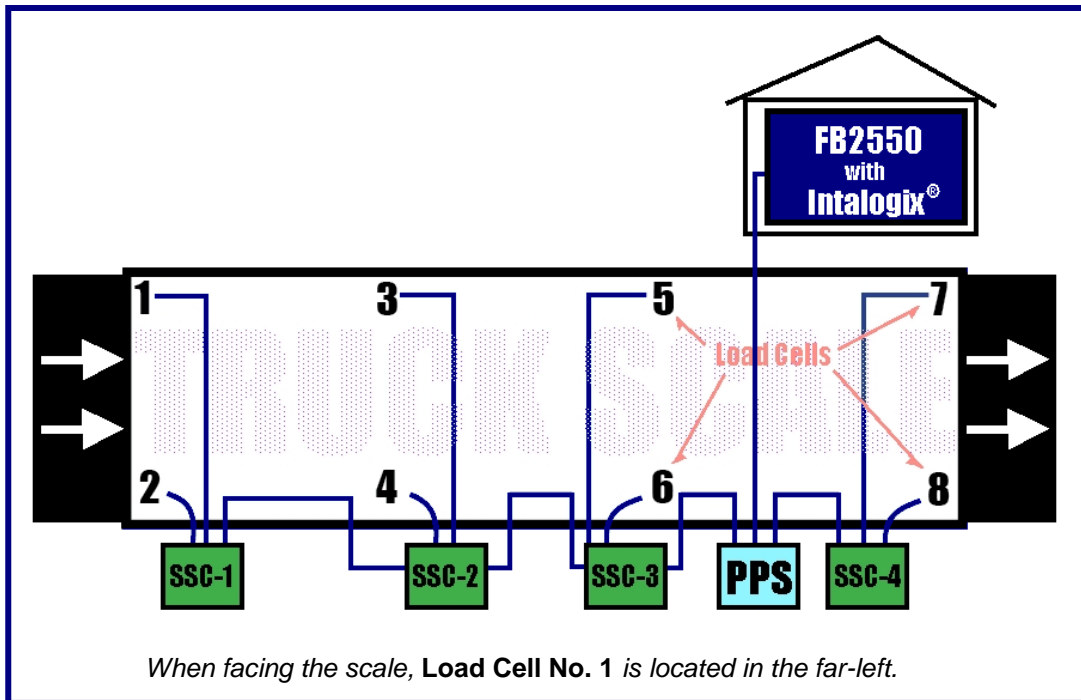
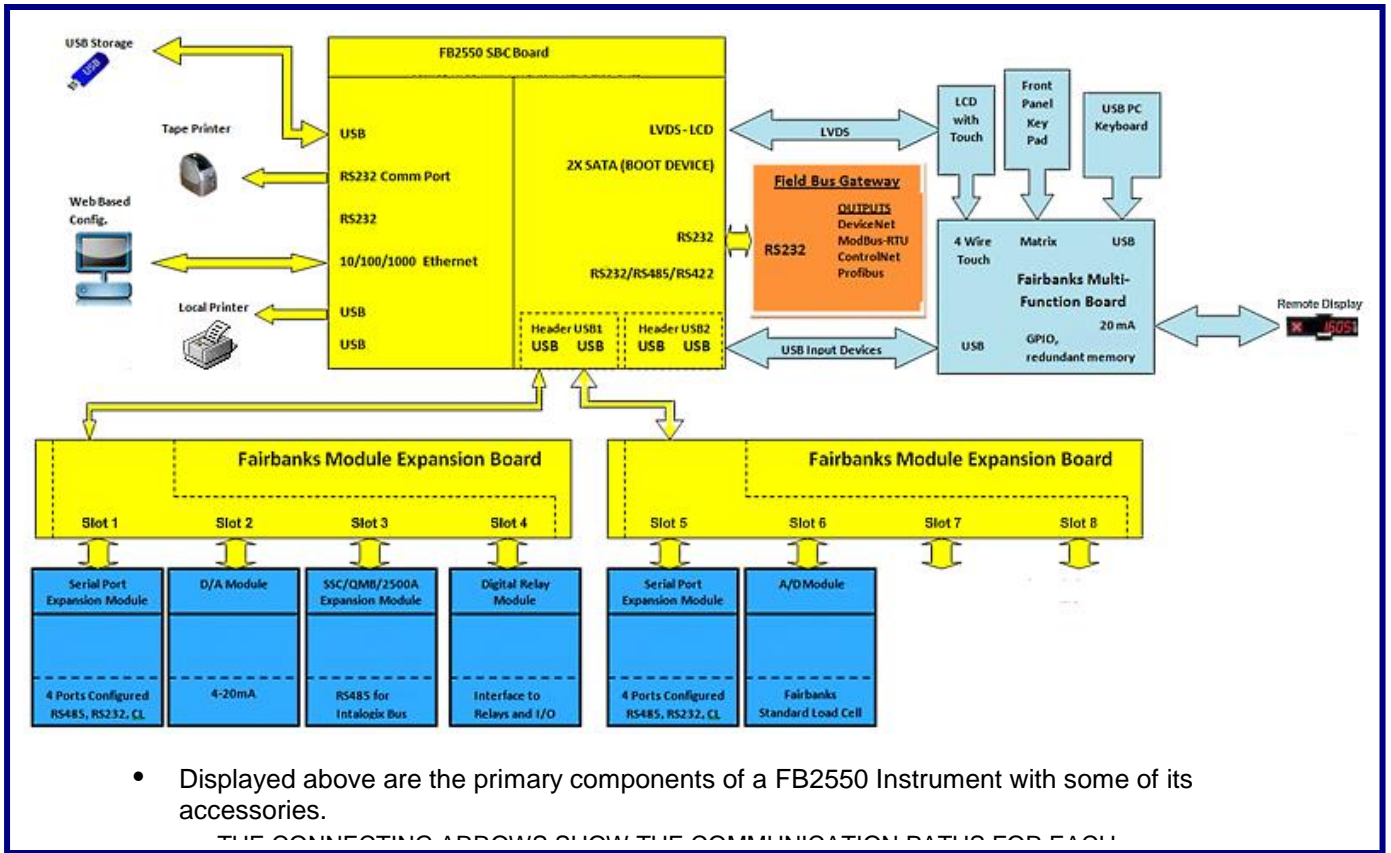



1.2. Specifications

Enclosure	Desktop (30770), Panel Mount (31053), Rack Mount (31173), NEMA 4 (31150)
BIOS	Award™ Software
Memory	1 GB RAM
Data Storage	2 GB Removable Micro SD Card
Operating System	Windows XP Professional Embedded, 8 GB Flash Module
Serial Outputs	Up to 12 serial ports and 4 built-in USB ports. <ul style="list-style-type: none"> - THE USB PORT ON THE MULTI-FUNCTION BOARD IS DEDICATED FOR A KEYBOARD ONLY.
Digital I/O	Up to 28 I/O Components
Ethernet Interface	PCI 10/100 Mbs Ethernet Complies with IEEE 802.3x Standards
Display	Seven inch (7") Diagonal Touchscreen LCD Color
Scale Interface Options	<ul style="list-style-type: none"> • Intalogix Technology <ul style="list-style-type: none"> - Intalogix Power Supply and Communications (30916) - Scale Interface Controller (30918) - External QMB Interface (30433) - External Intalogix Communication Box (33476) <ul style="list-style-type: none"> ▪ Maximum of twenty (20) 1000 Ω or twelve (12) 350 Ω cells - External Dual Intalogix Communication Box (32181). <ul style="list-style-type: none"> ▪ Up to forty (40) 1000 Ω or twenty-four (24) 350 Ω cells. • Analog Technology. <ul style="list-style-type: none"> - Internal Analog Load Cell Interface (5v excitation) (31079) <ul style="list-style-type: none"> ▪ Up to sixteen (16) 1000 Ω or eight (8) 350 Ω cells - External Analog Load Cell Interface (10v excitation) (31282) <ul style="list-style-type: none"> ▪ Up to sixteen (16) 1000 Ω or ten (10) 350 Ω cells - External Dual Analog Load Cell Interface (10v excitation) (31283) <ul style="list-style-type: none"> ▪ Up to sixteen (16 x 2 = 32) 1000 Ω, or ten (10 X 2 = 20) 350 Ω cells ▪ Maximum of two (2) per FB2550
Power Requirements	100 - 130 VAC @ 12A @ 60 Hz +/- 2 Hz <ul style="list-style-type: none"> - SEPARATE AND DEDICATED CIRCUIT. - NEUTRAL TO GROUND VOLTAGE SHOULD BE < 0.2 VAC - ONE AMP (1A) IS TYPICAL. TWELVE AMPS (12A) IS A FULLY EQUIPPED MODEL.
ETL Listed	<ul style="list-style-type: none"> • Conforms to UL STD 60950-1. • CAN/CSA C 22.2 NO.60950-1-03.
Approvals	<ul style="list-style-type: none"> • CC# 10-089 • MC# AM-5805

1.3. What is Intalogix Technology?

Intalogix® Technology is a unique method of individual load cell communication, providing outstanding resolution, performance and diagnostic capabilities.

It is the most advanced technology available for processing Analog Load Cells or Strain Gauge Outputs.

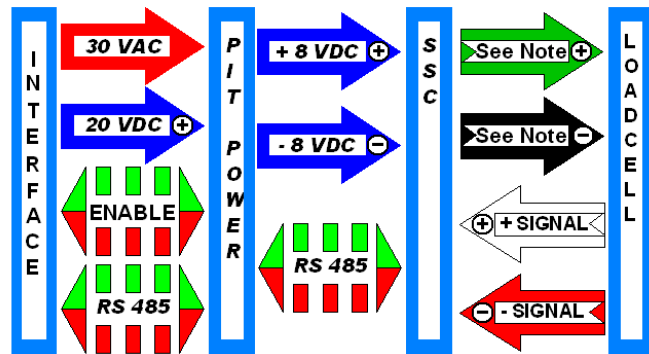

- The Interface supplies **30VAC** and **20VDC** to the Pit Power Supply (PPS), located at the scale platform.
- The “Enable” line controls the direction of the RS 485 half-duplex data weight communications from the Interface to the Smart Sectional Controller (SSC), and vice-versa.
- The PPS converts the AC to DC voltage, partially regulates it, and supplies it to the SSC, where it is further regulated and used to provide the **Excitation Voltage** to the Load Cells.
- The 20VDC is regulated in the PPS, and is used to supply the RS 485 Serial Communication Circuit.
- A switch setting in the SSC assigns it a Digital Address.
 - In the SSC, the Load Cell converts Analog signals into Digital signals, and then converts the Digital signals into RS 485.
 - The RS 485 Serial Communication from each SSC is then returned through the Pit Power Supply to the Instrument, where it is displayed as both Counts, and as Weight information, according to the programming parameters entered in the Instrument.

Older model SSC’s furnished (+/-) 5 VDC Excitation.

Newer model SSC’s furnish (+) 3.3 VDC and (-) 3.0 VDC Excitation.

SECTION 2: COMPANY SERVICE INFORMATION

2.1. General Service Policy

Prior to installation, always verify that the equipment satisfies the customer's requirements as supplied, and as described in this manual.

- If the equipment cannot satisfy the application and the application cannot be modified to meet the design parameters of the equipment, **the installation should NOT be attempted.**
- Instructions within this manual apply to the instrument and its specific accessories. Installation procedures for printers and other peripherals are given in manuals specifically provided for those units. The instructions include a pre-installation checkout which must be performed either at the service center before the technician goes to the site, or at the site before he places the equipment in service.
- All electronic and mechanical calibrations and/or adjustments required to make this equipment perform to accuracy and operational specifications are considered to be part of the installation, and are included in the installation charge. **Only those charges which are incurred as a result of the equipment's inability to be adjusted or calibrated to performance specifications may be charged to warranty.**
- Absolutely no physical, electrical, or program modifications other than selection of standard options and accessories are to be made to this equipment. Electrical connections other than those specified may not be performed, and no physical alterations (mounting holes, etc.) are allowed and will immediately void warranty

All load cells, load cell cables, and all interconnecting cables used for the scale components must be located a minimum of thirty-six inches (36") away from all single and multiple phase high energy circuits and electric current-carrying conductors.

- This includes, but is not limited to **digital weight instruments, junction boxes, sectional controllers, and power supplies.**
- This includes any peripheral devices, such as **printers, remote displays, relay boxes, remote terminals, card readers, and auxiliary data entry devices.**
- Scale components themselves must also be at least **thirty-six inches (36") away** from other high energy components, including the following devices.
 - Any machinery with outputs of **120, 240, or 480 volts AC.**
 - High voltage wiring runs and stations, AC power transformers, overhead or buried cables, electric distribution panels, electric motors, florescent and high intensity lighting which utilize ballast assemblies, electric heating equipment, traffic light wiring and power, and all relay boxes.
- Scale components are not designed to operate on internal combustion engine driven electric generators and other similar equipment.
 - This includes all digital weight Instruments and peripheral devices.
- Electric arc welding can severely damage scale components, such as digital weight Instruments, junction boxes, sectional controllers, power supplies, and load cells.

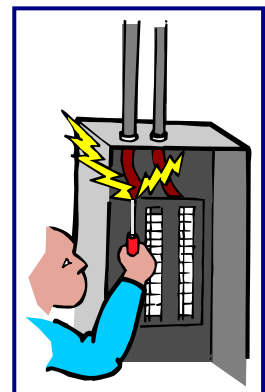

2.2. Users' Responsibilities

WARNING!

Absolutely no physical, electrical or program modifications other than selection of standard options and accessories can be made by customers to this equipment

Repairs are performed by Fairbanks Scales Service Technicians and Authorized Distributor Personnel ONLY!

Failure to comply with this policy voids all implied and/or written warranties

- ✓ **All electronic and mechanical calibrations and/or adjustments required for making this equipment perform to accuracy and operational specifications should be performed by *trained service personnel*.**
- ✓ **Absolutely no physical, electrical or program modifications other than selection of standard options and accessories are to be made to this equipment.**
 - Electrical connections other than those specified may not be performed
 - Physical alterations, such as holes, etc., are not allowed.

***Please call your local
Fairbanks Scales Representative
for any questions, problems, or comments.***



SECTION 3: SECURITY, LOGINS & PASSWORDS

3.1 Levels of Security

The following describes all the security levels for accessing the FB2550 DAT programs.

1. STANDARD USER or WEIGHTS & MEASURES OFFICIAL ACCESS

- **No password** is required with limited programming access.
- First Level Users can access these menus.
 - HOME
 - AUDIT TRAIL
 - OPERATOR MENU
 - RETURN TO WEIGHING

2. WRITE CUSTOMER LOGIN

- Allows all of the **Standard User** privileges.
- **Supervisor Users** can also access the **CONFIGURATION MENU**.
- The first-time-use **WRITE CUSTOMER Password** is **1**, suggested to be changed upon login.

3. REPORTS LOGIN (FOR SUPERVISORS ONLY)

- Used for programming and printing reports *from a remote location*.
- The **PASSWORD** must be **eight (8) characters**, and entered in the FB2550 Instrument.

4. SERVICE ACCESS

- All installation and programming responsibilities.

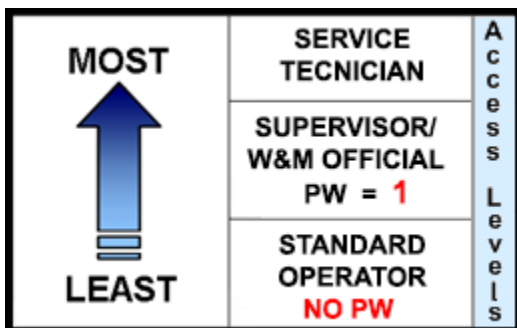

3.2. Login

Follow these steps to **LOGIN**.

1. While in the **WEIGHT SCREEN**, press the **MENU** button on the external keyboard to open the **Configuration Home Page**.
2. Select **LOGIN**.
3. Enter the **Write Customer** or **Service Password**.
4. Press the **LOGIN** button.

✓ **WRITE CUSTOMER PASSWORD = 1**

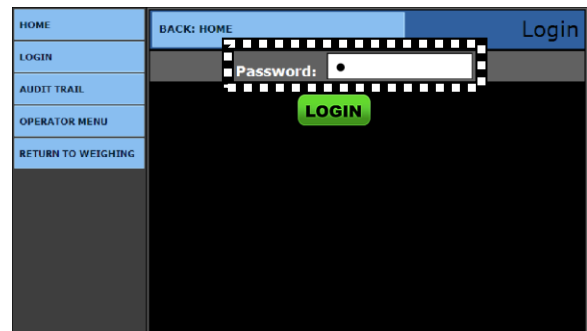
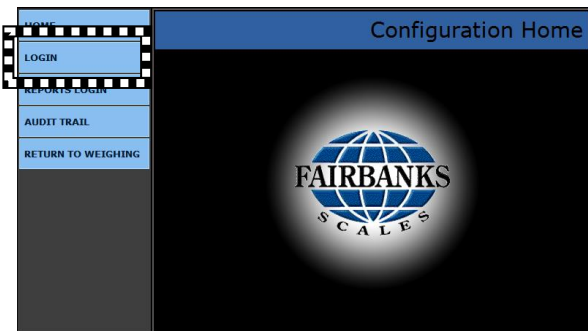

These are *first-time-use-only passwords*.

- Change the passwords to ones which are office-related, and use **both alpha and numeric characters**.
- Store the password(s) in a safe place **known by more than one manager**.
- It is recommended to change passwords **at least once a year**.
- Passwords are normally case-sensitive.
- The **REMOTE PASSWORD** is **eight (8) characters**.

IMPORTANT NOTE: An **External Keyboard Accessory (31036 or 25498)** is necessary for inputting tares, editing customers and products, and entering alphabetic text.

3.3. Reports Login

The **REPORTS LOGIN** is used for programming and printing Reports from a **remote location only**.

5. **Login remotely.**
6. While in the **WEIGH SCREEN**, press the **MENU** button.
7. Select **REPORTS LOGIN**.
8. Enter the **eight (8) character REMOTE PASSWORD**.
9. Press the **LOGIN** button.

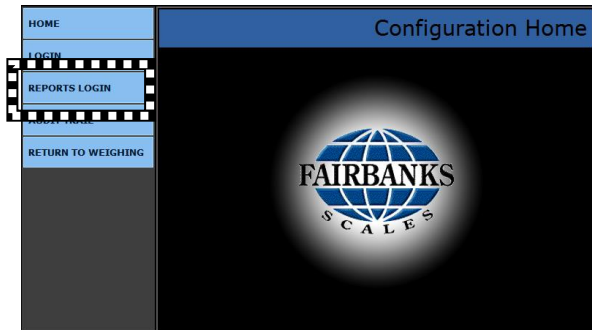

The **REPORTS LOGIN** option is only available when accessing the Instrument remotely.

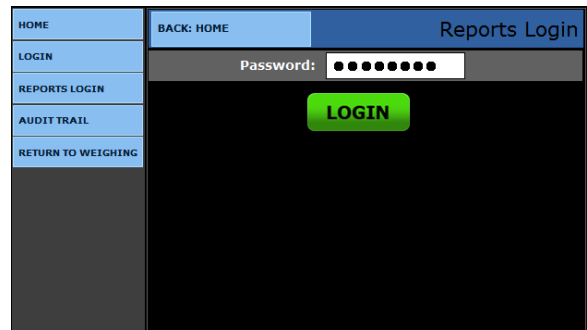

The **REMOTE PASSWORD** is eight (8) alphanumeric characters long.

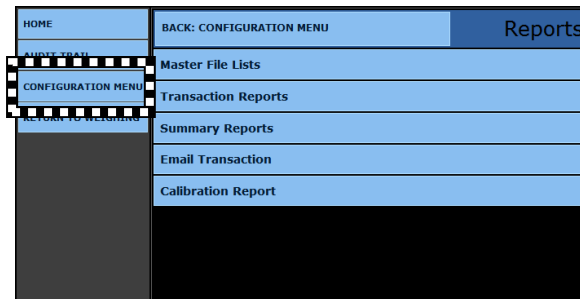

Remote Reports Menu

3.4. Changing Passwords

Noted below are suggestions for setting the first-time-use passwords.

- Passwords should be changed right after installation, and then stored in a safe place.
- Password characters are case-sensitive.
- Whenever possible, the password should use both alpha and numeric characters.
- These passwords should be known by more than one manager.
- It is recommended to change these passwords at least once a year.
- **REMOTE PASSWORDS** use *eight (8) characters*.

3.4.1. Write Customer Password

The **Write Customer Password** allows full-access to the **CONFIGURATION MENU** and all the lesser menus *when the supervisor is programming from a remote location*.

- The password can be any length
- This password *is case-sensitive*.

Follow these steps to change the **WRITE CUSTOMER PASSWORD**.

1. While in the **WEIGHT SCREEN**, press the **MENU** button on the external keyboard to open the **Configuration Home Page**.
2. Press **LOGIN**.
3. Enter the **Write Customer Password**.
4. Press the **LOGIN** button.
5. Open the **CONFIGURATION MENU**.
6. Select **WRITE CUSTOMER PASSWORD**.
7. Enter the **new password** in the **CONFIG PASSWORD** field, and again in the **CONFIRM PASSWORD** field.
 - Press the **SAVE CHANGES** button.

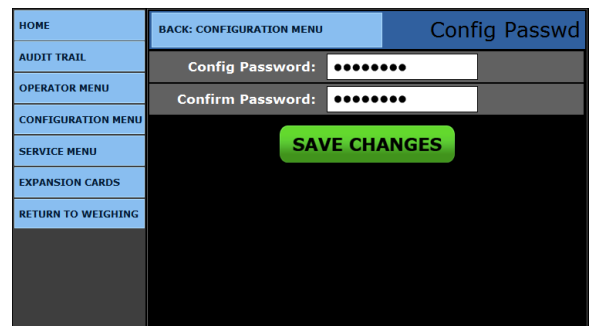
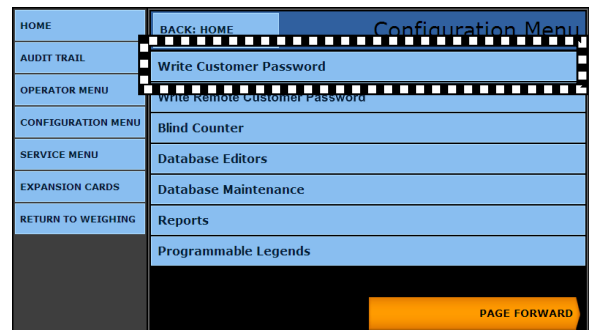

3.4.2. Write Remote Customer Password

The **REMOTE CUSTOMER** must be programmed on the Instrument before it can be accessed with a web browser. The supervisor can then program the Instrument from **any remote location** using a pc or laptop.

- The password is **case sensitive**, and must be **eight (8) characters**.

Follow these steps to change the **WRITE REMOTE CUSTOMER PASSWORD**.

1. While in the **WEIGHT SCREEN**, press the **MENU** button to open the **Configuration Home Page**.
 2. Press **LOGIN**.
 3. Enter the **Write Customer** or **Service Password**.
 4. Press the **LOGIN** button.
 5. Open the **CONFIGURATION MENU**.
 6. Select **WRITE REMOTE CUSTOMER PASSWORD**.
 7. Enter an **eight (8) character password** in the **REMOTE CONFIG PASSWORD** field.
 8. Reenter it in the **CONFIRM PASSWORD** field.
- Press the **SAVE CHANGES** button.

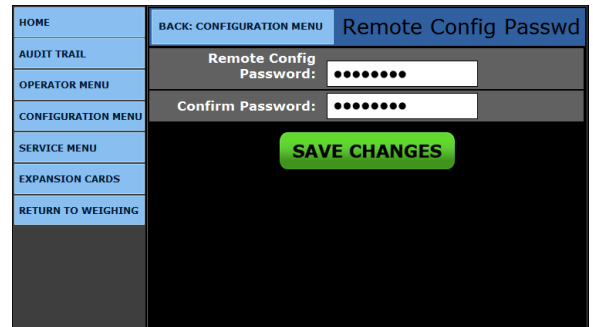
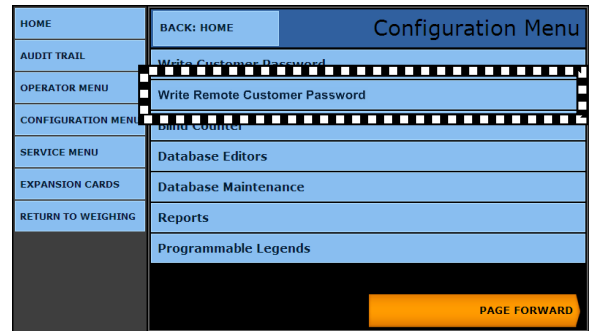

SECTION 4: STANDARD USER OPERATIONS

4.1. Introduction

4.1.1. Keypad Functions

KEY(S)	FUNCTION
Numeric Keys	These keys enter any NUMERIC DATA .
F1	Turns on Camera <i>(if enabled)</i>
F2	Expands Camera image to full screen <i>(if enabled)</i> .
F3	REPRINT TICKET – Reprints the previously printed ticket. <ul style="list-style-type: none"> When pressed while in the Weigh screen, it also displays a list of items, such as Loop, Customer, or Product during the weighing process..
F4	VOIDS – Permanently deletes the TICKET from the database.
F5	SHUTS DOWN the Instrument, <i>displays only when the scale is unloaded</i> . <ul style="list-style-type: none"> See Section 13.4. Proper Shutdown Procedure.
Enter	ACCEPTS/ STORES a data entry item.
Zero	ZEROs the scale.
Units	Toggles the UNITS option.
Print	Initiates a PRINT CYCLE .
Menu	Opens the CONFIGURATION HOME MENU , allowing the programming functions.
Arrow Keys	NAVIGATES through the programming choices.



IMPORTANT NOTE: An **External Keyboard Accessory (31036 or 25498)** is necessary for inputting tares, editing customers and products, entering alphabetic text, and for navigating thru program options.

4.1.2. External Keyboard Functions

KEY	FUNCTION
F1	Turns on Camera <i>(if enabled)</i>
F2	Expands Camera image to full screen <i>(if enabled)</i> .
F3	REPRINT TICKET – Reprints the previously printed ticket. <ul style="list-style-type: none"> When pressed while in the Weigh screen, it also displays a list of items, such as Loop, Customer, or Product during the weighing process..
F4	VOIDS – Permanently deletes a TICKET from the database.
F5	SHUTS DOWN the Instrument, <i>displays only when the scale is unloaded</i> . <ul style="list-style-type: none"> See 4.4. Proper Shutdown Procedure
Alphabetic Keys	Enters all ALPHABETIC TEXT .
Numeric Keys/ Keypad	Enters NUMERIC DATA .
Arrow Keys	NAVIGATES through the programming choices.
Esc	CLEAR, RESET, or RESTART the Instrument, if in the SLEEP Mode .
HOME	Opens the CONFIGURATION HOME MENU , allowing the programming functions.
PAUSE	ZEROs the scale.
SCROLL	Enters the UNITS .
PRINT SCREEN	PRINTS the ticket.

SHORTCUT KEYS	FUNCTION
Ctrl + Shift + H	Displays the SYSTEM INFORMATION .
Ctrl + Shift + S	Displays the installed EXPANSION MODULES .



4.2. Weighing Operations

4.2.1. Unloaded Scale Functions

When the scale is **unloaded**, the FB2550 Instrument activates these options by using the Function Keys.

F3 – REPRINT TKT

9. Press the **(F3) REPRINT TKT** function button.
10. Select from one of these two options.
 - a. Reprint Last Ticket.
 - b. Reprint By Ticket Number.
 - *THIS OPTION APPEARS ONLY WHEN A TICKET WAS PRINTED PREVIOUSLY.*
11. Press the **ENTER** button.

F4 – VOID (a ticket)

12. Press the **(F4) VOID** function button.
13. Input the **TICKET NUMBER**.
14. Press the **ENTER** button.
15. When the **WARNING!** message appears, press the **VOID** button.

F5 – POWER OFF

- For complete details, see **Section 4.4. Proper Shutdown Procedure.**

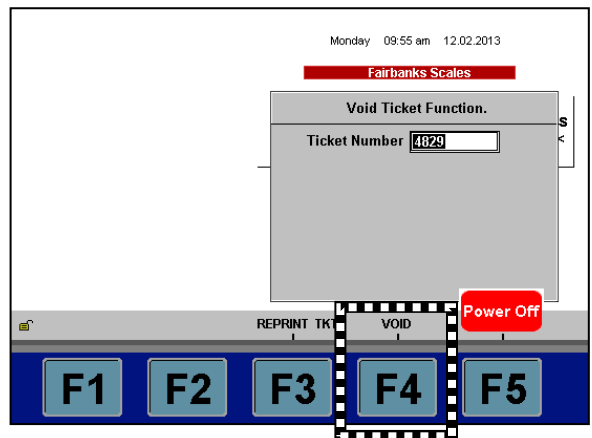
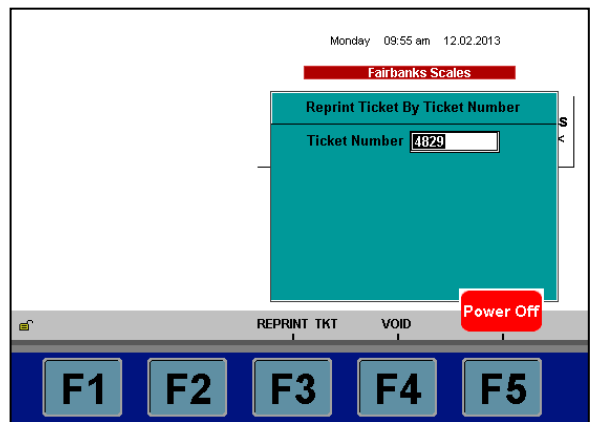
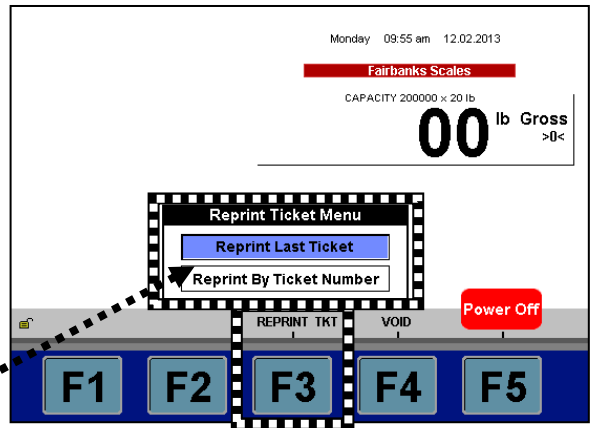

C A U T I O N

All VOIDED TICKETS are deleted,
and cannot be recovered.

4.2.2. Inbound/Outbound Weighing

Follow these steps to weigh using the **INBOUND/ OUTBOUND Mode**.

16. The truck pulls onto the scale.

- The weight and new action buttons appear on the Instrument display window.
- The Function Key options change.

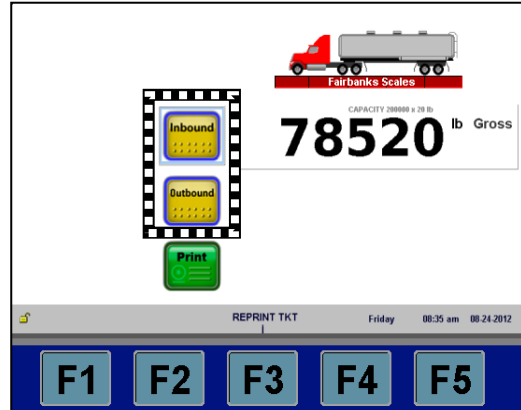

2a. Either the **Tag Reader** * identifies the vehicle and automatically generates the **LOOP ID NUMBER**,

OR...

2b. Input the **LOOP ID** number.

THEN...

3a. Press the **INBOUND** button if the truck is on its initial weighment.

- A **"PROCESSING TRANSACTION"** message displays first, followed by an **"INBOUND TRANSACTION STORED"** message.

OR...

3b. Press the **OUTBOUND** button if the truck is on its secondary weighment.

- A **"PROCESSING TRANSACTION"** message displays first, followed by an **"COMPLETED TRANSACTION STORED"** message.

4. Press the **ENTER** button on the keyboard to save the transaction.

- Two windows display briefly, noting the transaction processes is complete.

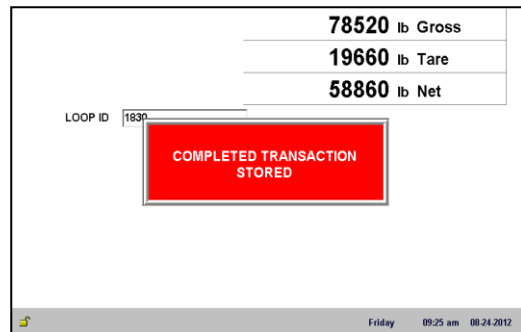
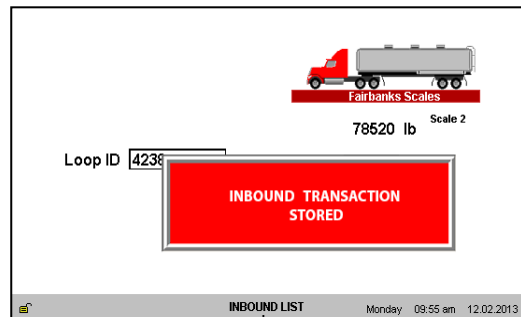
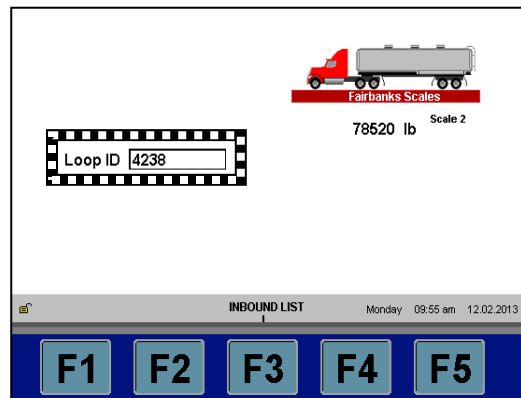

* The Tag Reader (**TransCore RFID Reader – 10-4002-009**) is an optional accessory.

4.2.2. Inbound/Outbound Weighing, Continued

INBOUND LIST (F3)

1. To see all of the incomplete transactions, press the **INBOUND LIST (F3)** button.
 - This function key option shows the details of an incoming truck on the scale.

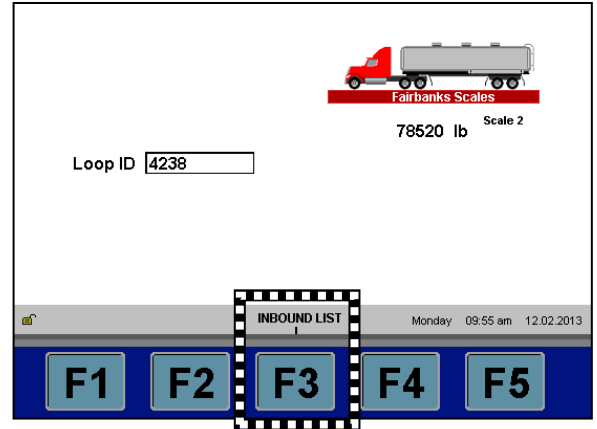

2. Press the **UP** and **DOWN ARROW** button to select the correct transaction.
3. Either press the **ENTER** button on the keypad to save and process the transaction,

OR...

4. Press the **PRINT** button and deliver the ticket copy to the driver.

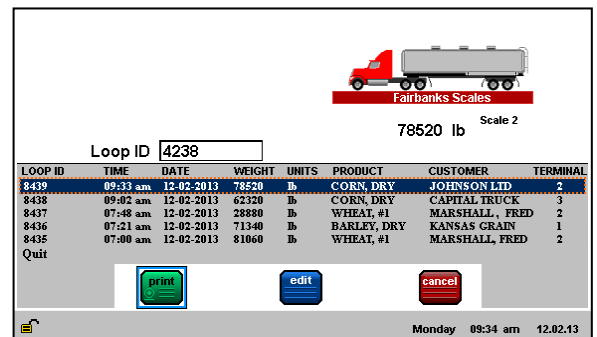

4.2.3. Gross Weighing

1. Drive the vehicle to be weighed on the platform.
2. Once the display stabilizes, press the **PRINT** key.
 - A **Gross Weight** ticket prints.

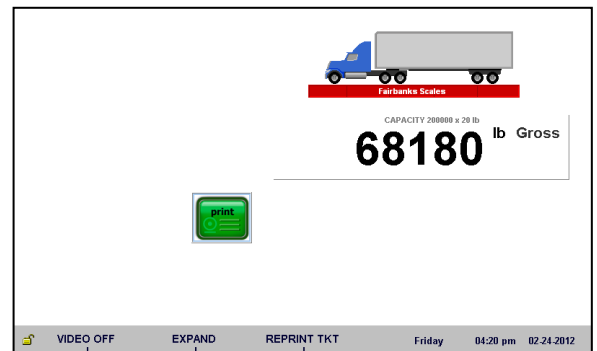

4.2.4. Gross/Tare/Net Weighing

1. Drive the vehicle to be weighed on the platform.
 - a. Press either the **KEY TARE** or **TARE** button.
 - b. If **KEY TARE** is selected, enter the known **Tare Weight** on the keypad.
 - c. If **TARE** is selected, the weight on the display is captured as a **Tare Weight**.
2. Press the **ENTER** button on the keypad.
3. Load the vehicle with product.
4. Press the **PRINT** key, and a **Gross-Tare-Net Ticket** is printed.
 - **Mode Change** – When a **KEY TARE** or **TARE** button is pressed, the scale automatically switches from the **Gross Weighing Mode** to the **Gross-Tare-Net Mode**.
5. To change the scale from the **Gross-Tare-Net Mode** back to the **Gross Weighing Mode**, press the **KEY TARE** button.

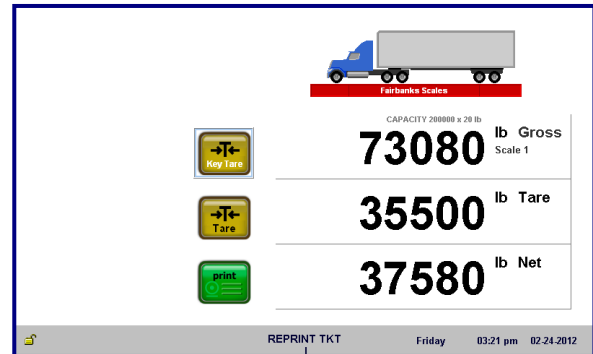

NOTE: *If the display shows cell(s) failure, this indicates an error on the platform.*

Check the platform for equipment, debris, or other materials and remove them. If this does not resolve the condition, call for service.

4.3. Operator Menu Programming

The **OPERATOR MENU** allows user programming operations to the instrument.

- Allows access to change the **TIME AND DATE, TICKET NUMBER, and LOAD CELL DIAGNOSTICS** (*read only view*).
- **No password** is required for these options.

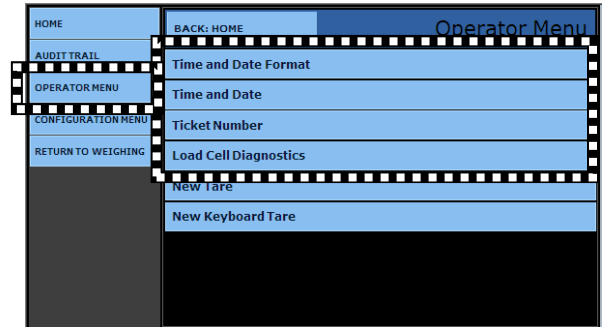

4.3.1. Time and Date Format

This function programs how the Time and Date will display on the Instrument screen.

1. Press the **MENU** button.
2. Open the OPERATOR MENU.
3. Select the best **TIME FORMAT**.
4. Open the **AM/PM** option, then select either the **12 HOUR** or **24 HOUR** format.

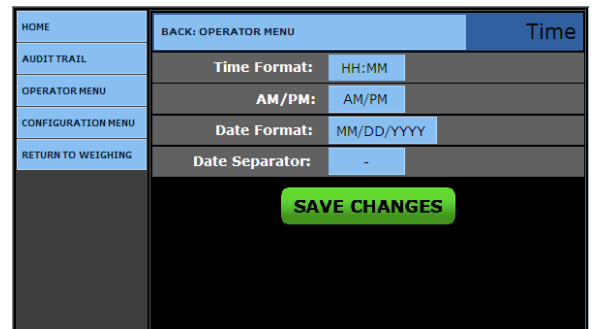

5. Select the **DATE FORMAT**.
 - **H** = Hour
 - **M** = Minute
 - **S** = Second

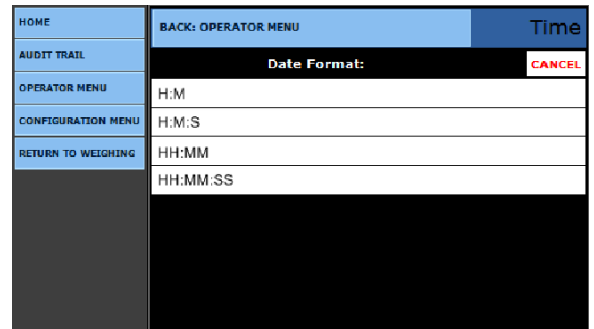

6. Select the best **DATE SEPERATOR** formats, which include a (**SPACE**), **/**, and **-**.

- Press the **SAVE CHANGES** button when any changes are made, or they **will be lost**.
- Select **BACK: OPERATOR MENU** to return to the previous menu.

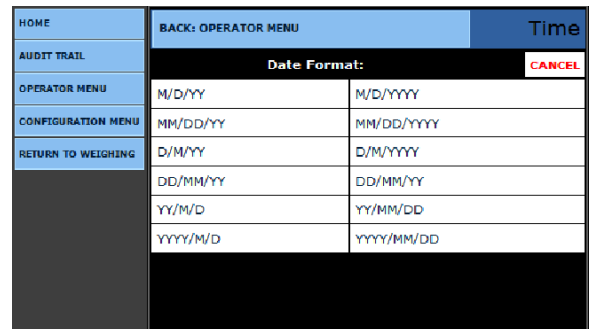

4.3.2. Time and Date

This function sets the **Time and Date** for the Instrument.

7. Enter the **YEAR, MONTH, DAY, HOUR,** and **MINUTE** options into the box next to the legend.
8. Press the **SAVE CHANGES** button when any changes are made, or they **will be lost**.

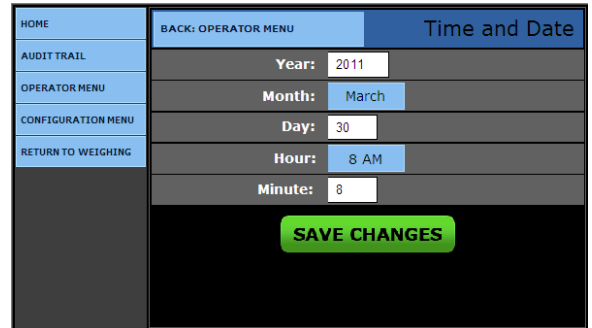

4.3.3. Ticket Number

This function opens a ticket for viewing and editing.

9. Enter the **TICKET NUMBER** by typing the correct value into the box next to the legend.
 - Allows a maximum entry of **six (6) digits**.
 10. Enter the **MACHINE ID** by typing the correct value into the box next to the legend.
 - This resets the **Loop ID Value**.
- ✓ **DEFAULT = 1**

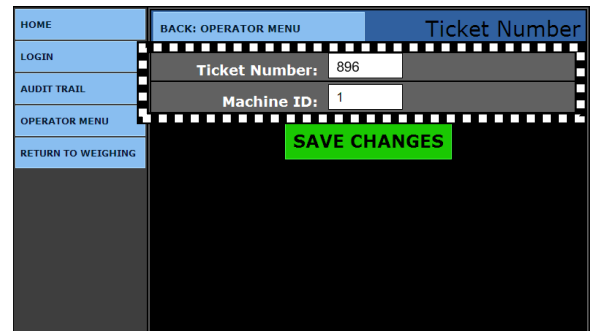

- Press the **SAVE CHANGES** button, or they will be lost.
- Select **BACK: OPERATOR MENU** to return to the previous menu.

4.3.4. Load Cell Diagnostics

Instruments equipped with Intalogix® technology have **Load Cell Diagnostics** features for easier troubleshooting capabilities.

- To view **LOAD CELL DIAGNOSTICS**, select the correct scale.

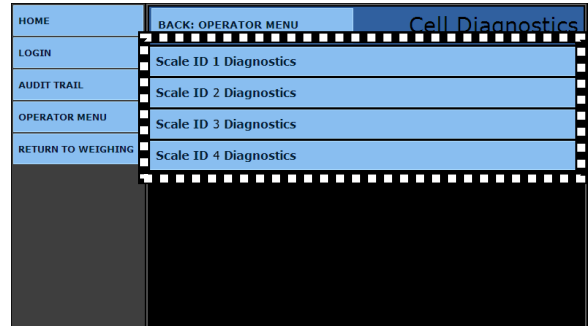

The **DIAGNOSTICS** screen gives a quick snapshot of how each load cell is performing.

- CELL** – Identifies the load cell in the scale platform.
- STATUS** – Compares the load cell output to stored calibration values and posts a **GOOD** or **BAD** condition.
- COUNTS** – Displays the load cell’s current counts.
- GHOST** – When the load cell communications uses Intalogix™ Interface, the system electronically duplicates the load cell in the same section.
 - This is mostly used for troubleshooting faulty load cells.
- FLAG** – Visual flags (*) are used to identify problem load cell(s) on the diagnostic screen until the flag is manually cleared .
 - This improves the ability to identify intermittent issues.

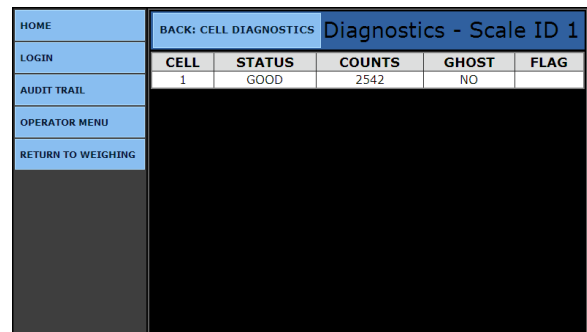

NOTE: The **TARE** programming functions are unavailable to **Standard Operators**.

4.4. Proper Shutdown Procedure



- When there is no weight on the scale, the **POWER OFF (F5)** notification displays.
- Whenever there is weight on the scale, the **F5** button is still active, but the legend is hidden.
 - A **Shut Off Warning** appears whenever **F5** is pushed and there is weight on the scale.
- The **POWER OFF (F5)** is inactive during any programming activities.

Follow these steps to properly shutdown the FB2550 Instrument.

1. While in the Weigh Screen and with nothing on the scale platform, press the **F5** key.
 - A **Shut Off Warning** appears.
2. Press **ENTER**, or touch the **YES**.
3. After proper shut-down is complete, **ALWAYS UNPLUG THE INSTRUMENT** from AC power.
 - Until the FB2550 is unplugged from AC power, it will continue to supply operating voltage to the instrument circuits.
4. Plug back in the Instrument to reboot it.

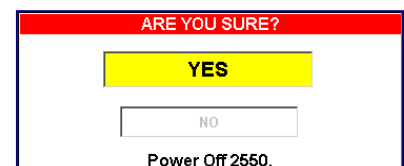

SECTION 5: AUDIT TRAIL

5.1. Login

The **AUDIT TRAIL** used primarily used by the **Weights & Measures Officials** to make scheduled site inspections.

5. While in the **WEIGH SCREEN**, press the **MENU** button.
6. Press **LOGIN**.
7. Enter the **Write Customer Password** .
8. Press the **LOGIN** button.
9. Select **AUDIT TRAIL**.
10. Choose either **CALIBRATION AUDIT TRAIL**, or **CONFIGURATION AUDIT TRAIL**.

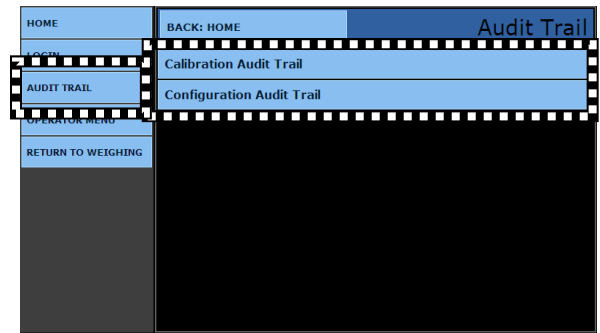

5.2. Calibration Audit Trail

The **CALIBRATION REPORT** denotes exactly when the scale calibrates.

- This option has **view-only access**, and cannot be edited.
- It displays the **Time(s)**, **Date(s)** and a random **Count**, which is incremented to each of up to eight (8) displayed scales.
 - *The **Count** is a numeral of up to six (6) digits, determined randomly by the Instrument as an identifier.*

The screenshot shows a 'Calibration Report' screen with a blue header bar containing 'HOME', 'BACK: AUDIT TRAIL', and 'Calibration Report'. Below the header, there are menu options: 'LOGIN', 'AUDIT TRAIL', 'OPERATOR MENU', and 'RETURN TO WEIGHING'. The 'AUDIT TRAIL' option is highlighted with a dashed border. Below the menu options, there is a table with the following data:

Scale	Time	Date	Count
1	03:47 PM	11/15/2010	95431
3	11:08 AM	05/29/2013	11965
2	01:15 PM	05/29/2013	4562

5.3. Configuration Audit Trail

The **CONFIGURATION REPORT** displays all configuration changes.

This option has **view-only access**, and cannot be edited.

- It displays the **Time(s)**, **Date(s)** and the random **Count**.

The screenshot shows a 'Configuration Report' screen with a blue header bar containing 'HOME', 'BACK: AUDIT TRAIL', and 'Configuration Report'. Below the header, there are menu options: 'LOGIN', 'AUDIT TRAIL', 'OPERATOR MENU', and 'RETURN TO WEIGHING'. The 'AUDIT TRAIL' option is highlighted with a dashed border. Below the menu options, there is a table with the following data:

Scale	Time	Date	Count
1	04:54 PM	01/15/2011	9534
2	10:15 AM	06/21/2013	10002
3	01:22 PM	06/21/2013	4235

SECTION 6: PROGRAMMING

6.1. Introduction

While in the Weigh Screen, press the **MENU** button on the keypad to access the **CONFIGURATION HOME** window.



HOME	Returns the user to the Configuration Home Page .
AUDIT TRAIL	Identifies how many times and when changes are made to the scale's Calibration or Configuration settings. <ul style="list-style-type: none">• See SECTION 5: AUDIT TRAIL for more information.
OPERATOR MENU	User access for Time/Date , Ticket Number , Load Cell Diagnostics , and Keyboard Tare entries. <ul style="list-style-type: none">• See SECTION 7.2: OPERATOR MENU for more information.
CONFIGURATION MENU	Accesses communications programming and functions, ticket formats, programmable legends and prompts, camera inputs and weight threshold. <ul style="list-style-type: none">• See SECTION 7.3: CONFIGURATION MENU for more information.
RETURN TO WEIGHING	Returns the user to the Weight Display Screen .

IMPORTANT NOTE: An **External Keyboard Accessory (31036 or 25498)** is necessary for inputting tares, editing customers and products, and entering alphabetic text.

6.2. Shortcut Keys

Described below are the shortcut programming keys. The **Weigh Screen** must first be displaying before any of these Shortcuts will function.

KEYS	FUNCTION(S)
MENU Button	Opens the PROGRAMMING menus.
CTRL + Shift + C	Opens the TOUCH SCREEN CALIBRATION .
CTRL + Shift + H	Displays the SYSTEM INFORMATION .
CTRL + ALT + Shift + R	Opens the DATABASE RECOVERY MENU . <ul style="list-style-type: none"> - INCLUDED ARE REBOOT INSTRUMENT, ATTEMPT RECOVERY, AND RESTORE TO FACTORY SETTINGS BUTTONS.
CTRL + Shift + S	Displays all the installed EXPANSION MODULES . <ul style="list-style-type: none"> - INCLUDED ARE CHECK FOR UPDATES AND RESCAN BUTTONS.
Ctrl + Alt + F12	Opens the DUAL DISPLAY MENU .
F5	Initiates the system SHUTDOWN . <ul style="list-style-type: none"> - SEE Section 4.4. Proper Shutdown Procedure FOR COMPLETE DETAILS.

IMPORTANT NOTE: An **External Keyboard Accessory (31036 or 25498)** is necessary for inputting tares, editing customers and products, and entering alphabetic text.

While in the **Weigh Screen**, press the **MENU** button access the programming menus.

C A U T I O N !

FB2550 Instrument must be shut down properly!

Failure to shut down properly can result in corrupting essential software files necessary for proper operation, and lead to the replacement of the 8Gb Flash Drive.

ALWAYS press the **F5** key to start the Shutdown Process.

NEVER unplug the FB2550 Instrument to reboot it!

See [4.4. PROPER SHUTDOWN PROCEDURE](#) for complete details.

6.3. Customized Instrument Configurations

Configure FB2550 Instrument with the following menu functions.

- Programmable Legends
- Vehicle Images
- Entry Sequence Prompts
- Programmable Prompts
- Threshold Weights
- Blind Counter

6.4. Programmable Legends

Follow these steps to customize the FB2550 Instrument legends.

1. While in the **WEIGH SCREEN**, press the **MENU** button on the external keyboard.
2. Select **LOGIN**.
3. Enter the **Write Customer Password** or **Service Password**.
4. Press the **LOGIN** button.
5. Select the **CONFIGURATION MENU**.
6. Press select **PROGRAMMABLE LEGENDS**.
7. The data entry boxes accept keyboard alphanumeric entries to customize the legends the users will view when operating the instrument.
 - Twenty (20) characters maximum.

EXAMPLE

Loop ID: **ENTER TRUCK LICENSE NUMBER**
 Scale 1: **NORTH SCALE 1**

8. Press the **PAGE FORWARD**.
9. Program the **Legends** for **SCALES 5** thru **8**.
 - Press the **SAVE CHANGES** button, or they will be lost.
 - Select **BACK: CONFIGURATION MENU** to return to the previous menu.

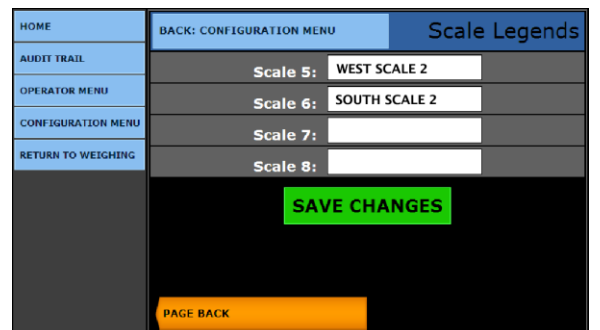
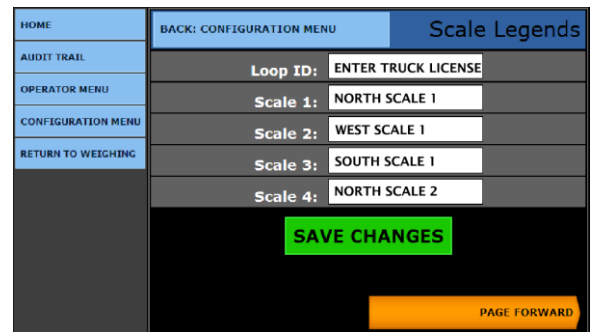
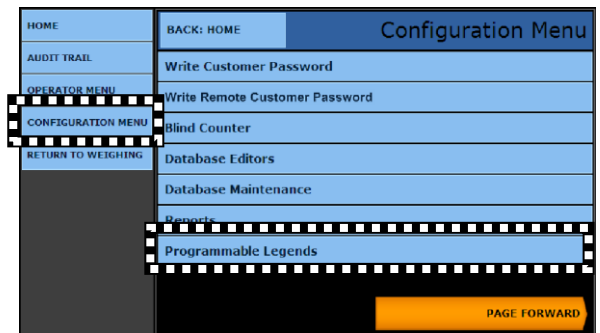
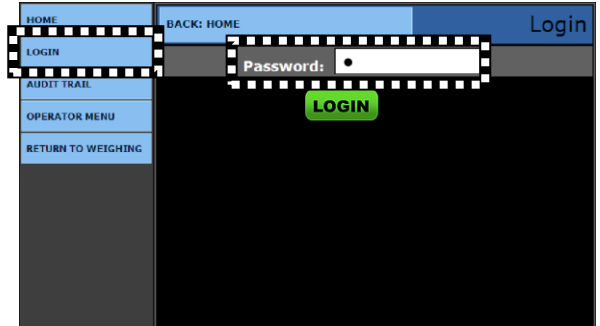

6.5. Programmable Prompts

Follow these steps to customize the Programmable Prompts.

- There are **ten (10)** prompts available.
- 1. While in the **CONFIGURATION MENU**, press **PAGE FORWARD**.
- 2. Select **PROGRAMMABLE PROMPTS**.
- 3. Touch the **EDIT THE ENTRY PROMPT X** to access the data entry screen for the custom prompt.
- 4. In the data entry box to the right of the **Name:** legend, enter the **PROMPTS NAME** or **DESCRIPTION**.
- 5. The data boxes to the right of the legends **GTN:**, **Inbound:**, and **Outbound:** will enable or disable the prompt for a combination of Inbound, Outbound or GTN operations.

- ✓ **NO = DISABLE**
- ✓ **YES = ENABLE**

EXAMPLES

Name: **TRAILER NO.**
 Name: **BILL OF LOADING NO.**

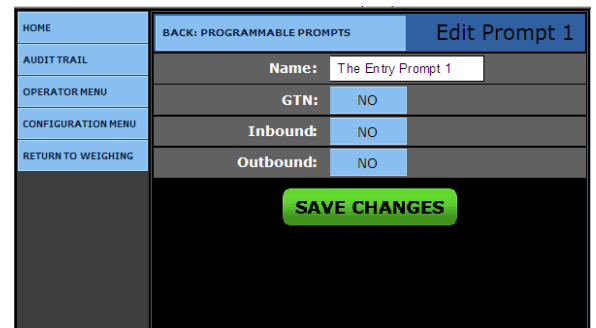
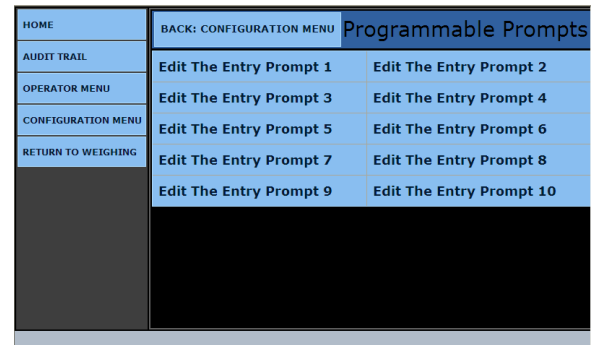
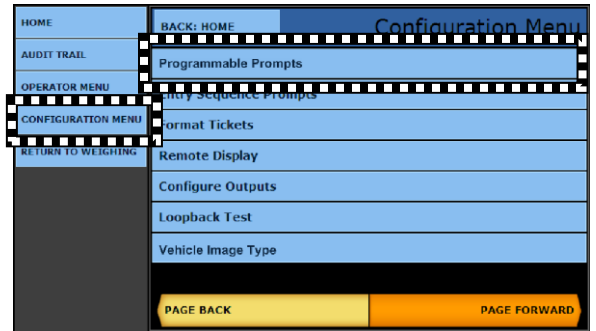

- Press the **SAVE CHANGES** button, or they **will be lost**.
- Select **BACK: CONFIGURATION MENU** to return to the previous menu.

6.6. Entry Sequence Prompts

The **ENTRY SEQUENCE PROMPTS MENU** enables the built-in **customer and product prompts** for a combination of the **Inbound, Outbound, or GTN** operation sequences

The **Loop ID GTN** and **Tare GTN prompts** are enabled or disabled with this window.

1. While in **CONFIGURATION MENU**, press the **PAGE FORWARD** button once.
2. Select **ENTRY SEQUENCE PROMPTS**.
3. In the **LOOP ID GTN** menu, enter **YES** to *enable* or **NO** to *disable* the **LOOP ID PROMPT** when a GTN operation is performed.
4. In the **TARE GTN** menu, enter **YES** to enable or **NO** to disable the **TARE PROMPT** when a GTN operation is performed.

✓ *The **Loop ID GTN** and **Tare GTN** must both be set to **YES** to perform the **IN/OUT** operation.*

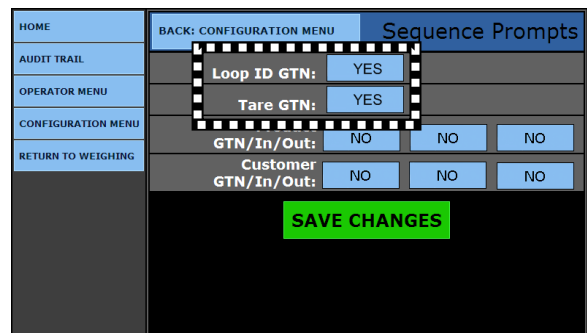
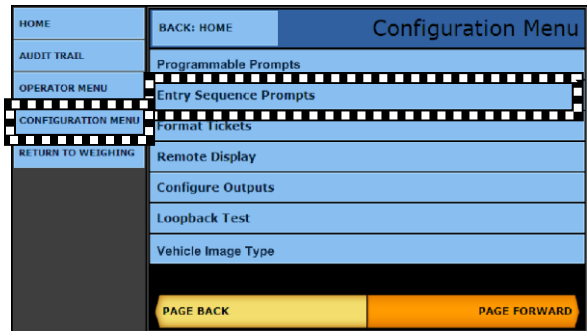

5. In the **PRODUCT** and **CUSTOMER** menus, enter **YES** to enable or **NO** to disable the prompt when a **GTN** operation is performed.
 - Press the **SAVE CHANGES** button, or they will be lost.
 - Select **BACK: CONFIGURATION MENU** to return to the previous menu.

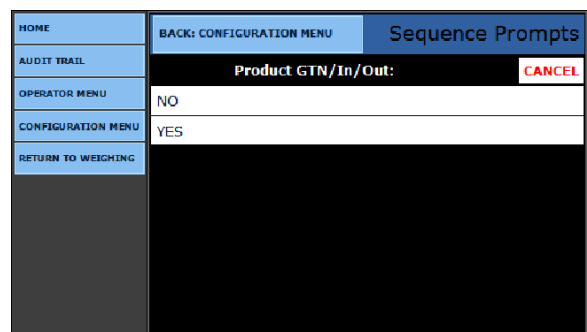







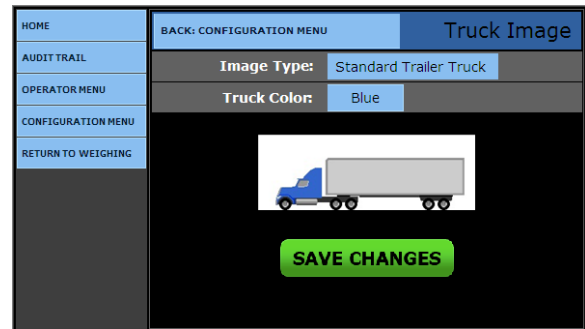
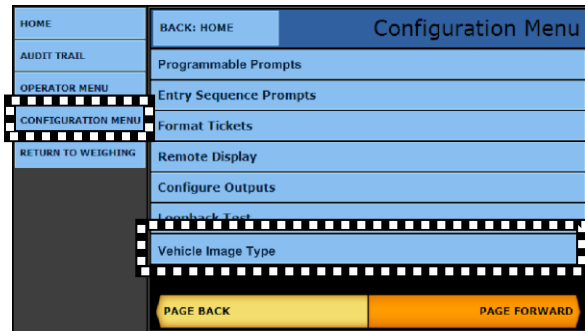



6.7. Vehicle Image Type

Follow these steps to customize the FB2550 Instrument truck image.

1. While in the **CONFIGURATION MENU**, press the **PAGE FORWARD** button once.
2. Select vehicle **IMAGE TYPE**.
3. Select the **IMAGE TYPE BOX** to access the available truck images.



<ul style="list-style-type: none"> • Standard Trailer Truck 	<ul style="list-style-type: none"> • Flatbed Trailer Truck 	<ul style="list-style-type: none"> • Tanker Trailer Truck 
<ul style="list-style-type: none"> • Dump Truck 	<ul style="list-style-type: none"> • Waste Truck 	<ul style="list-style-type: none"> • Tanker Car 
<ul style="list-style-type: none"> • Lumber Car 	<ul style="list-style-type: none"> • Grain Car 	<ul style="list-style-type: none"> • Flat Car 
<ul style="list-style-type: none"> • Coal Car 	<ul style="list-style-type: none"> • Box Car 	<ul style="list-style-type: none"> • No Image

4. Select the **TRUCK COLOR** Option.
 - Red
 - Green
 - Black
 - Orange
 - Blue
 - Brown
 - Yellow
 - Purple
 - Gray
- Press the **SAVE CHANGES** button when any changes are made, or they will be lost.

6.8. Threshold Weights

1. While in the **CONFIGURATION MENU**, press **PAGE FORWARD** once.
2. Select **THRESHOLD WEIGHTS**.

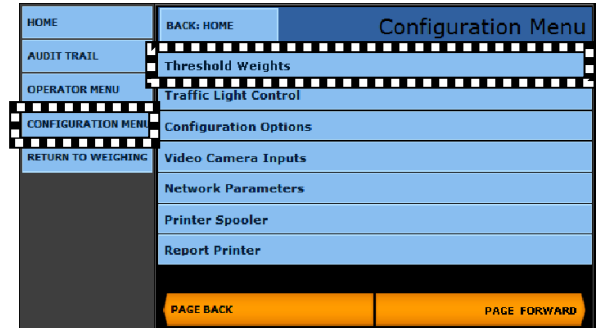

INITIAL WEIGHT sets the minimum amount the truck must weigh to initiate a weighment.

FINAL WEIGHT triggers an alert when the weight on the last section scale meets or exceeds the value entered.

- Used on a full electronic truck scale.
- *Not used* in the **MANUAL MODE OF OPERATION**.
- The data entry boxes to the right of the legend identifiers will accept keyboard numeric entries to enter the values required.

- ✓ **Default INBOUND WEIGHT = 1,000 lbs.**
- ✓ **Default FINAL WEIGHT = 2,000 lbs.**

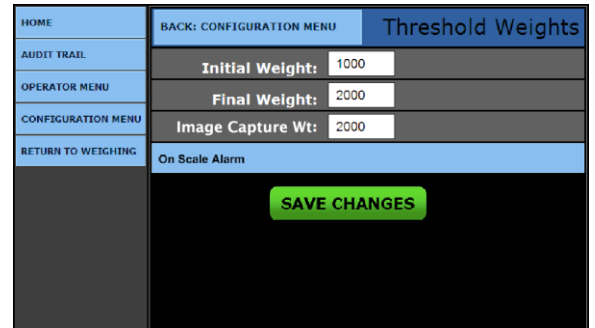

IMAGE CAPTURE WEIGHT sets the amount when a truck on the scale has a picture taken of it as it weighs, stored within that transaction and used for identification.

- Press the **SAVE CHANGES** button when any changes are made, or they will be lost.

6.9. On Scale Alarm

The **ON SCALE ALARM** gives an audio and visual alert whenever the **Threshold Weight** meets or exceeds the **Initial Weight**.

Follow these steps to set the parameters of the **On Scale Alarm**.

- In the **THRESHOLD MENU**, press the **ON SCALE ALARM** button.

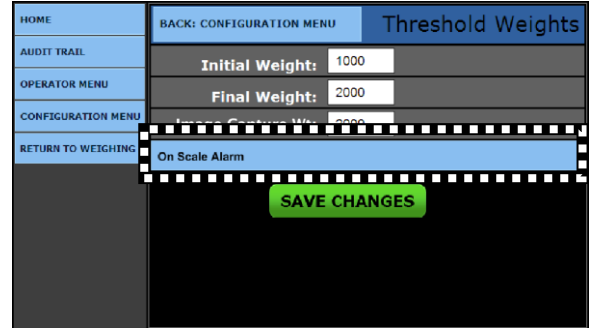

- Enter the **THRESHOLD WEIGHT** amount.
- Open **Alarm Type**, and select the correct one.

OFF	No alarm.
POPUP ONLY	Visual Alarm Message popup window, written by supervisor.
INTERNAL BUZZER	Audio alarm made by the Instrument.
RELAY BD-1 / RELAY BD-2 <i>(Relay Boards 1 & 2)</i>	Trips a relay that activates a device, which sounds an alarm, turns on a light, or activates another signal to alert users. <ul style="list-style-type: none"> Each board can control up to eight (8) relays.

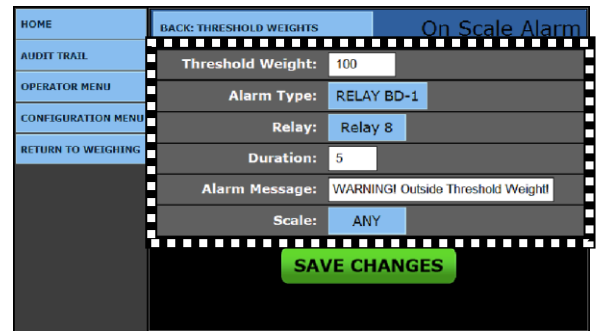

- Select **RELAY 1** thru **8**.
- Set the alarm **DURATION** (in minutes).
 - **1** to **99** minutes.
- Input the visual **ALARM MESSAGE** for the popup message.
- Enter either **one specific scale**, or **ANY**.

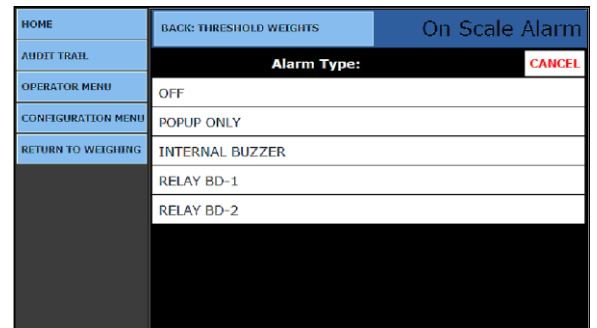

- Press the **SAVE CHANGES** button when any changes are made or they will be lost.
- Select **BACK: CONFIGURATION MENU** to return to the previous menu.

6.10. Blind Counter

1. While in the **CONFIGURATION MENU**, select **BLIND COUNTER**.

The **BLIND COUNTER** monitors all activity on the scale and triggers an event whenever any active scale exceeds the **Initial Weight Threshold**.

- The **BLIND COUNTER** does not generate a print.
- This records all activities that do not result in a print, as long as the Initial Weight Threshold is met and stable for **ten (10) seconds**.

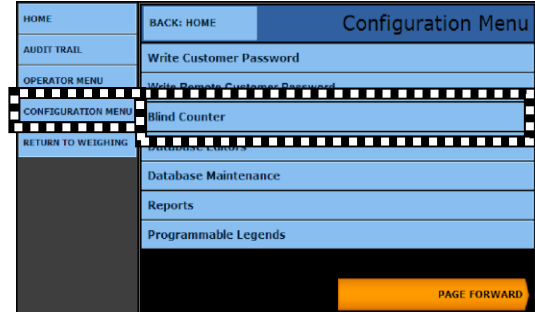

Output may be directed to **FILE OUTPUT, COM PORT OUTPUT, or both**.

If the unit uses cameras, an image can be captured, depending on the configuration.

- The system supports up to **two (2) cameras**.

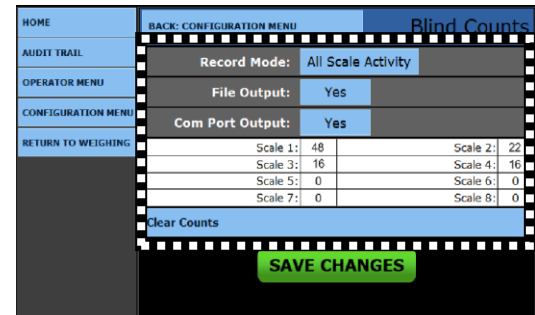

2. Open the **RECORD MODE** window to select how the data is stored, if at all.

- **OFF** disables the **Blind Counter**.
- **ALL SCALE ACTIVITY** records all the weighments.
- **NO DATA STORED/TICKET PRINTED** records data if it is not stored on a weighment or a printed ticket.

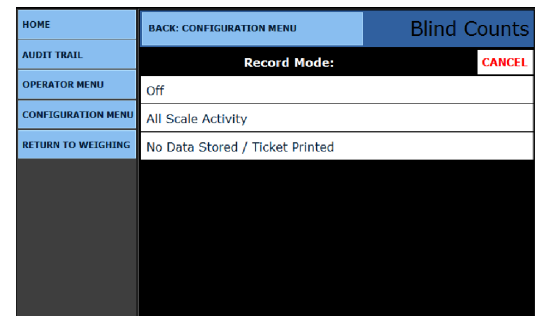

3. Click the **FILE OUTPUT** button, and then select **YES** or **NO**.

- Sends the weighment data to a specific application folder.

4. Click the **COM PORT OUTPUT** button, then select **YES** or **NO**.

5. Answer **YES** to send the transaction through one of the **Configured Output** serial ports.

- These must be configured for this purpose.
- **Blind Counter Transaction data** will begin with a **BLIND COUNTER** legend for identification.

6. Click the **CLEAR COUNTS** button to reset the **BLIND COUNTER** to zero (0).

- Press the **SAVE CHANGES** button when any changes are made or they will be lost.

SECTION 7: SUPERVISOR PROGRAMMING

7.1. Introduction

CONFIGURATION HOME is the first menu that appears after the **Write Customer Login**.

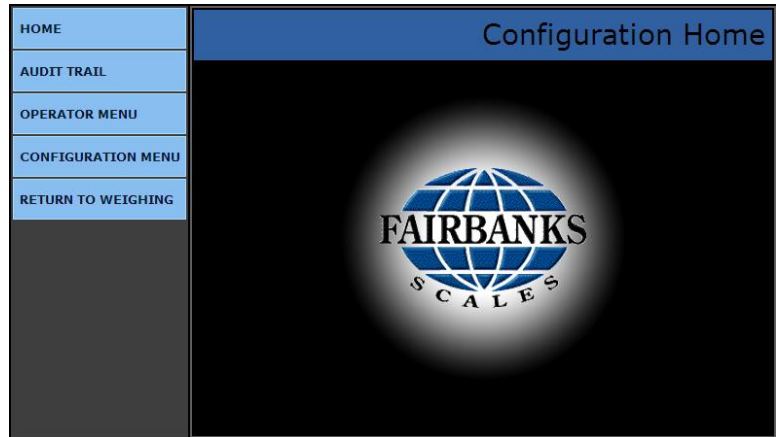

HOME	Returns the operator to the Configuration Home page
AUDIT TRAIL	Identifies how many times and when changes have been made to the scale's Calibration or Configuration settings.
OPERATOR MENU	User access for Time/Date, Ticket Number, Load Cell Diagnostics, and Keyboard Tare entries.
CONFIGURATION MENU	Write Customer access to communications programming and functions, ticket formats, programmable legends and prompts, camera inputs and weight threshold.
RETURN TO WEIGHING	Returns the user to the Weighing Display Screen.

IMPORTANT NOTE: An **External Keyboard Accessory (31036 or 25498)** is necessary for inputting tares, entering all alphabetic characters, such as editing customers and products.

7.2. Operator Menu

7.2.1. Entering a New Tare Automatically

It is necessary to **LOGIN** with the **Write Customer Password** when programming the **TARE** functions in the **OPERATOR MENU**.

1. While in the **WEIGH SCREEN**, press the **MENU** button.
2. Select **LOGIN**.
3. Enter the **Write Customer Password**.

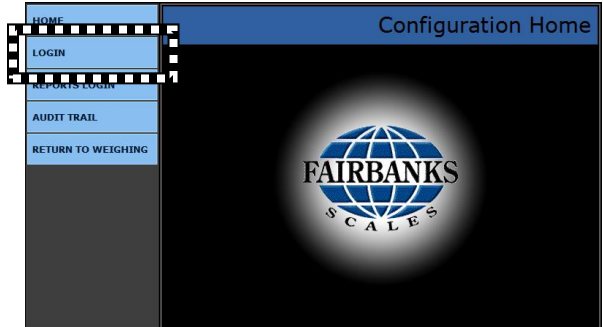

✓ **First-time-use default = 1**

4. Press the **LOGIN** button.

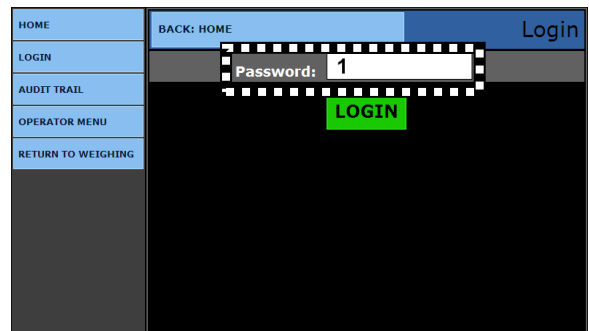

5. Select the **OPERATOR MENU**.
6. Open the **NEW TARE** option.
7. Enter the **TARE ID** numeric value to store and recall a tare weight saved.
 - The **Tare Weight** value is what is currently on the scale.
 - This value cannot be edited.
8. Select the correct **UNITS** value.

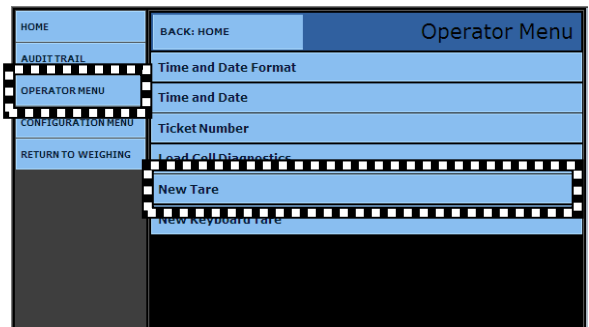

A **Tare Date** generates automatically when the Tare is entered.

The **Manual Tare** option is not used in this programming menu.

9. Enter the **VEHICLE DESCRIPTION**.
 - This is a unique description or label for the tare weight.

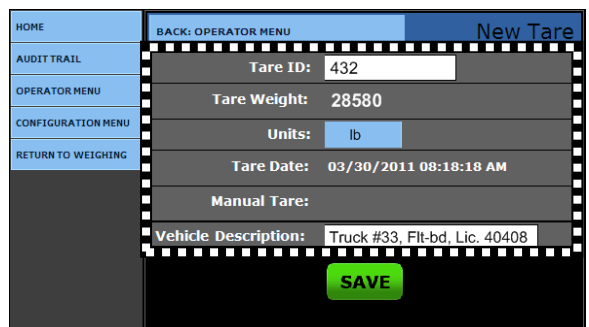

7.2.2. Entering a New Keyboard Tare

1. While in the **OPERATOR MENU**, open the **NEW KEYBOARD TARE** option.
2. Using the Keyboard, enter a new **TARE ID** numeric value to save and recall the **tare Weight**.
3. Enter the **TARE WEIGHT** manually using the keyboard.
4. Select the **UNITS** for the new Tare.
 - The **Tare Date** records the date and time the tare generates automatically.
 - The **Manual Tare** is a flag designating the tare is manually entered.
5. Enter the **VEHICLE DESCRIPTION**.
 - This is a unique description or label for the tare weight, and how it is associated.

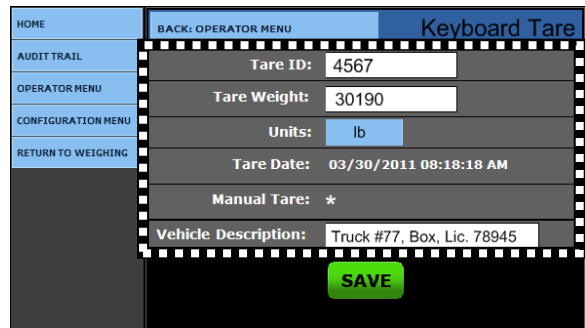
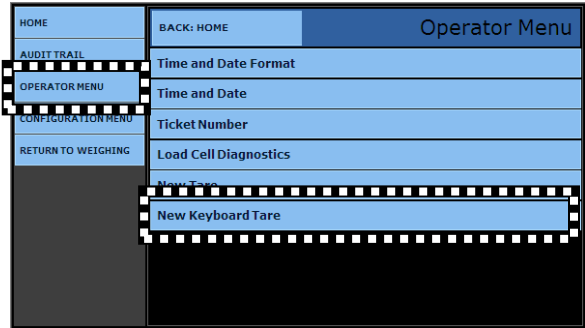

7.2.3. Resetting the Ticket Number

Follow these steps to reset the **Ticket Number**.

1. While in the **OPERATOR MENU**, select **Ticket Number**.
2. Set the **Machine ID** to **ONE (1)**.
 - This window also resets the **Ticket Number**, as needed.
- Press the **SAVE CHANGES** button, or they will be lost.
- Press **BACK: EXIT** to return to the previous menu.

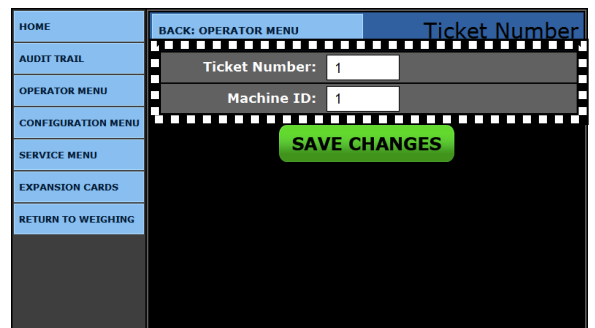
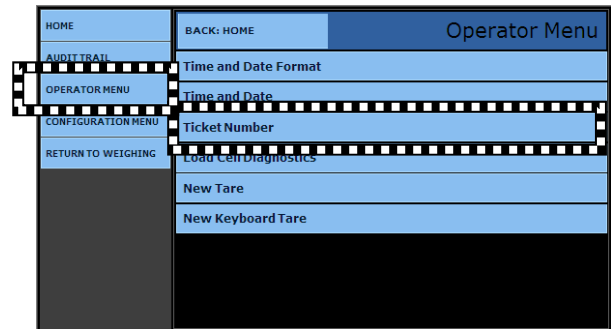

7.3. Configuration Menu

These functions add, update and delete all the data input needed for scale system.

7.3.1. Edit Customers

The FB2550 Instrument stores customer's name and address, as well as information used for reporting accumulated weights.

1. While in the **CONFIGURATION MENU**, press **Database Editors**.

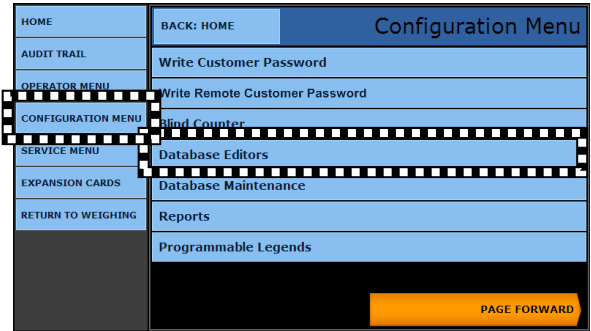

2. Select **EDIT CUSTOMERS**.

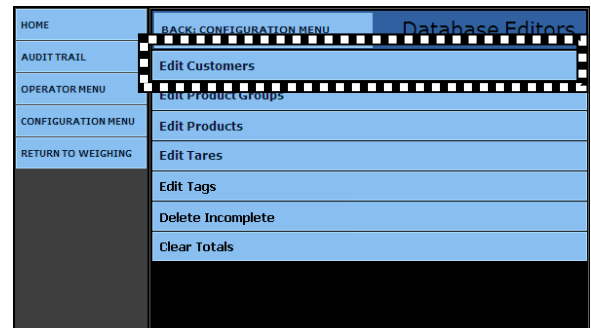

The first time a customer will be entered, the screen will appear as shown.

- 3a. Press the **NEW CUSTOMER** button.
- 3b. Enter the **NEW CUSTOMER** information.

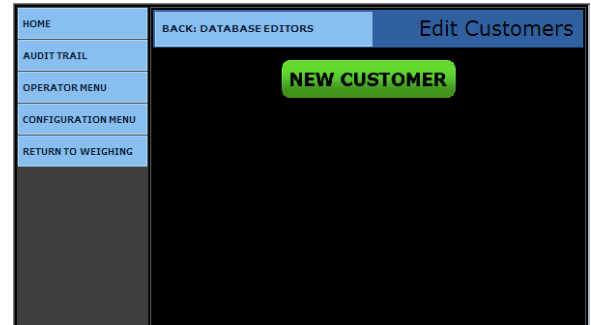

OR...

- 3c. Open the existing **customer record** which needs editing or updating.



7.3.1. Editing Customers, Continued

3. Enter the unique customer number in the **CUSTOMER ID** data entry box.

- When selecting a pre-existing Customer, the **CUSTOMER ID** will generate automatically.
- The customer must be previously created before the truck's data will populate automatically.
- The **TOTAL** data entry box is automatically populated and updated at every weighment that uses the **CUSTOMER ID** value.
- This provides a running total of **NET WEIGHT** for each customer.

4. Select the **PRODUCT GROUP** from the list.

- The **PRODUCTS** must first be created before they can apply to the **PRODUCT GROUPS**.

5. Input any pertinent company information in the **ADDRESS ONE** thru **FOUR (1 – 4)** data entry boxes.

- Include the business name, address(es), phone numbers, and point-of-contact names.

- Press the **SAVE CHANGES** button, or they will be lost.

7.3.2. Edit Products

1. Enter new and edit existing products in **EDIT PRODUCTS** menu.

- The FB2550 Instrument stores up to **999,999** product and customer files.
- They are used for calculations and reporting.

2. While in the **CONFIGURATION MENU**, select the **DATABASE EDITORS** button.

3. Select **EDIT PRODUCTS**.

7.3.2. Edit Products, Continued

3a. Press the **NEW PRODUCT** button to generate a new one.

3b. Enter the new **PRODUCT ID**.

- This number is usually from a product inventory list.

OR

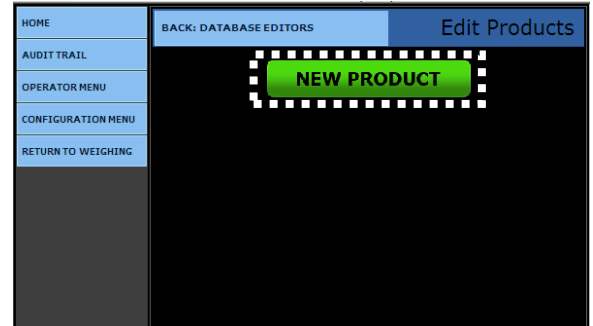

3c. Highlight the correct **PRODUCT**, then press the **NEW PRODUCT** button to edit an existing product.

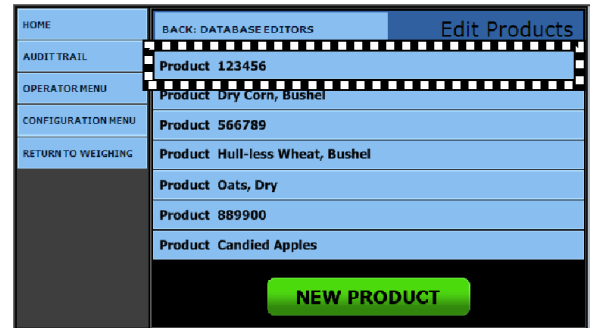

OR

3d. Enter the **PRODUCT ID** in the data entry box.

- Each product entered has an identification value for recalling it in the weighing process.

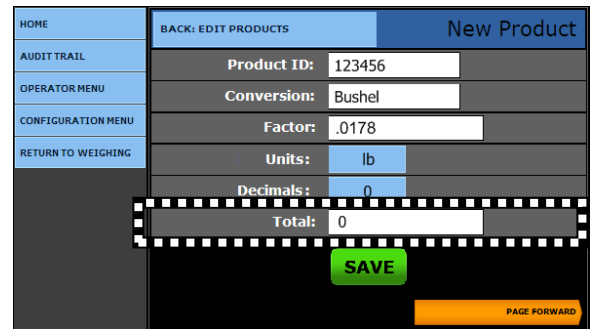

4. Enter **TONS, METRIC TONS, TONNES**, or **BUSHELS** in the Conversion field.

5. Set the **Total** input field.

- This is an accumulated *net* weight value.
- Enter a value of an existing amount, such as **“1960”**, **“0”** as the starting reference.

✓ **Total Default = 0**

7.3.2. Edit Products, Continued

- Enter the **FACTOR** value in the entry field.
 - This value converts the weight to another unit's value.
 - The **Factor** is multiplied by the **Net Weight** of a transaction.
 - To obtain the Factor, divide the conversion value of the unit into **ONE (1)**.

EXAMPLES

2000 lbs = 1 ton
 Deriving
 Factor: = 1/2000
 Factor: = **.0005**

56 lb = 1 bushel of shelled corn
 Deriving
 Factor: = 1/56
 Factor: = **0.017857**

- Press the **UNITS** button to select the measurement unit processed and displayed for each Product.
- Press the **DECIMALS** button to select the number of places to the right of the decimal for the conversion result.

The **Total** data entry box is automatically populated and updated upon every weighment which utilizes the **Product ID** value.

- This provides a running total of **Net Weight** for each product.
- Manually enter a **ZERO** to reset the accumulator.

✓ **New Product Default = 0**

- Press the **PAGE FORWARD** button.
- Press the **SAVE** button, or they will be lost.
- Select **BACK: EDIT PRODUCTS** to return to the previous menu.

7.3.2. Edit Products, Continued

9. Select the **CONVERSION 2** option if a second one is used by the customer.
 - Press the **SAVE** button, or they will be lost

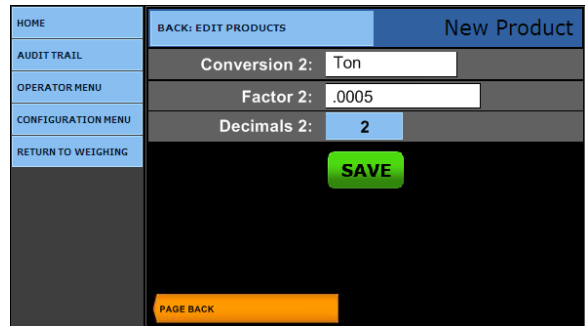

7.3.3. Edit Product Groups

A **PRODUCT GROUP** is a filter to permit only specifically selected products to be used by a customer.

- These groups are assigned to a customer from the **Edit Customers menu**.

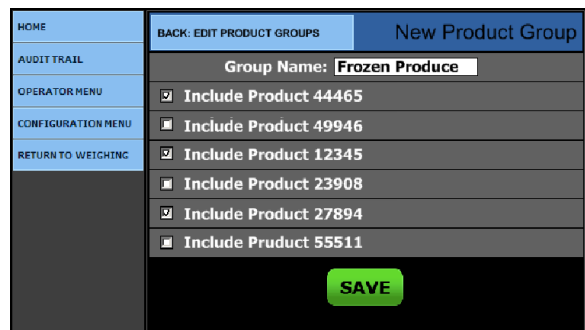

WORKING EXAMPLE

A vehicle weighs Inbound on the scale. The scale operator is prompted for **Loop ID**, **Customer ID**, and **Product ID**. When the **Product ID** is selected, a drop-down menu appears with the products the customer is limited to use.

Product IDs must be created first, before a **Product Group** is created.

1. While in the **WEIGH SCREEN**, press the **MENU** button.
2. Select **LOGIN**, then enter the **Service Password**.
3. Press the **LOGIN** button.
4. Select the **CONFIGURATION MENU**.

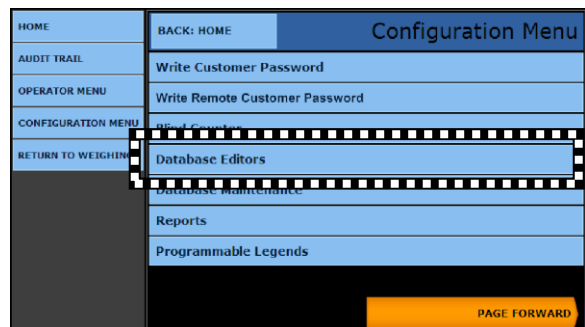

5. Select **DATABASE EDITORS**.

7.3.3. Edit Product Groups, Continued

6. Select **EDIT PRODUCT GROUPS**.

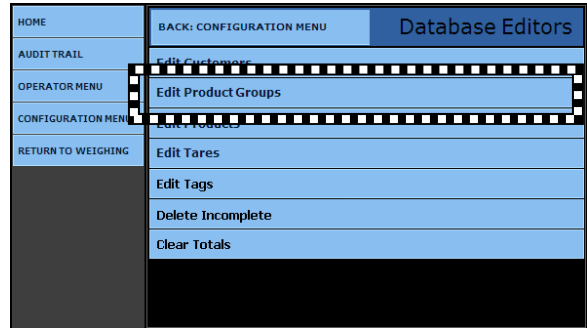

7. Assign a **GROUP NAME** for the new Product Group.

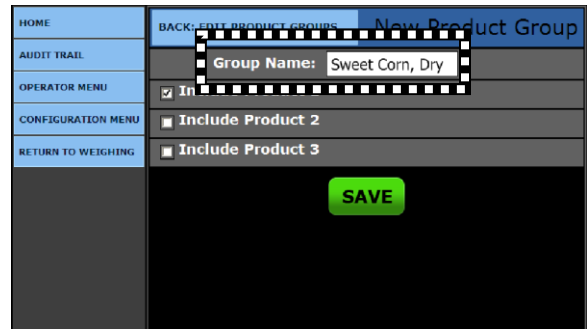

8. Place a check besides the **PRODUCT(S)** to be included in the group.

9. Press the **SAVE** button when any changes are made, or they will be lost

- Check any of the Products, then press the **DELETE** button to remove the **Product Group**.

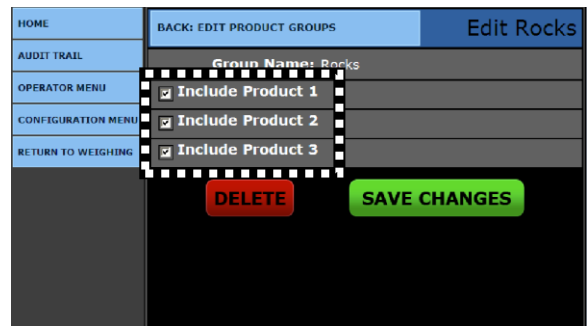

CAUTION

Deleting the **Product Group** will affect the operation of the FB2550 Instrument with many customers that use the group.

7.3.4. Edit Tares

The **EDIT TARES** option provides a quick access to all the active stored tares.

1. While in the **CONFIGURATION MENU**, press the **DATABASE EDITORS** button.

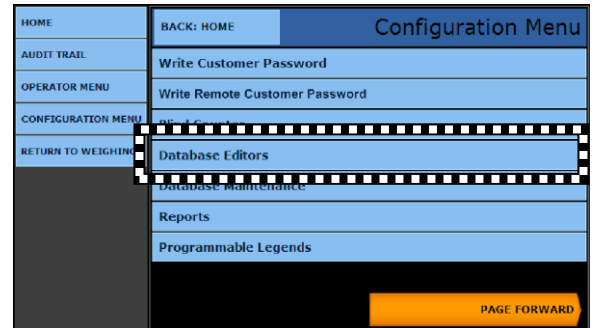

2. Select **EDIT TARES**.

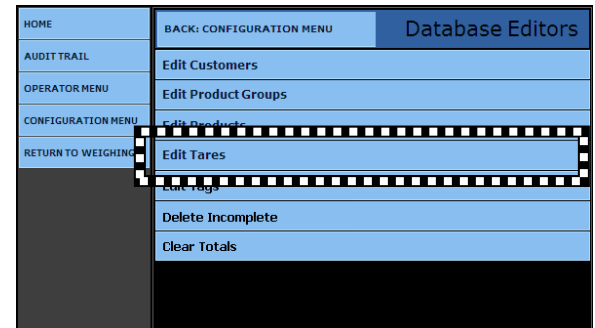

- 3a. Press an existing **TARE** to edit it,

OR...

- 3b. Press the **NEW TARE** button create one,

OR...

- 3c. Press the **KEYBOARD TARE** button to add one using the keyboard.

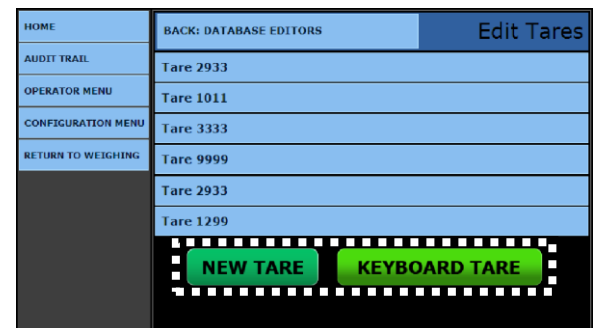

7.3.4. Edit Tares, Continued

4. Enter the **TARE ID**.
 - This is a numeric value entered to store and recall the tare weight saved.
 5. Enter the **TARE WEIGHT** from the scale.
 - This value cannot be edited.
 6. Enter the **UNITS** from the available choices.
 7. The **Tare Date** records the date and time the tare generates automatically.
 8. The **Manual Tare** is a flag designating the tare is manually entered.
 9. Enter the Vehicle Description.
 - This is a unique description or label for the tare weight and how it is associated.
 10. Press the **SAVE** button when any changes are made, or they will be lost.
 - This exits to the **Edit Tares Menu**
- Select **BACK: OPERATOR MENU** to return to the previous menu.

HOME	BACK: OPERATOR MENU	New Tare
AUDIT TRAIL	Tare ID: 432	
OPERATOR MENU	Tare Weight: 28580	
CONFIGURATION MENU	Units: lb	
RETURN TO WEIGHING	Tare Date: 03/30/2011 08:18:18 AM	
	Manual Tare:	
	Vehicle Description: Truck #33, FLT-bd, Lic. 40408	
	SAVE	

7.3.5. Edit Tags

TAG ID FILES are used only with the **FB2550 DAT Instrument**, and *do not apply to the FB2550 Inbound/Outbound unit.*

HOME	BACK: CONFIGURATION MENU	Database Editors
AUDIT TRAIL	Edit Customers	
OPERATOR MENU	Edit Product Groups	
CONFIGURATION MENU	Edit Products	
RETURN TO WEIGHING	Edit Tares	
	Edit Tags	
	Delete Incomplete	
	Clear Totals	

7.3.6. Deleting Incomplete Transactions

Through the course of normal operation of the FB2550 Instrument, an error may occur. An **Incomplete Transaction** is then created.

Follow the steps below to remove and delete **Incomplete Transactions** from the database.

1. While in the **CONFIGURATION MENU**, select **DATABASE EDITORS**.

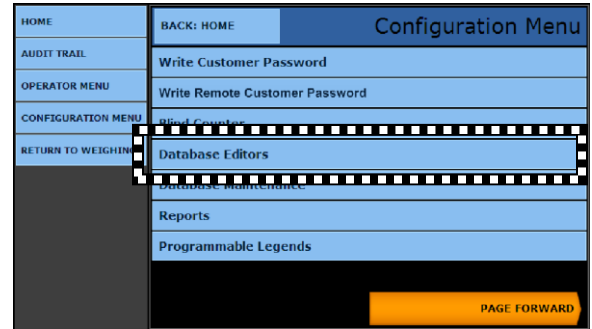

2. Select **DELETE INCOMPLETE**.

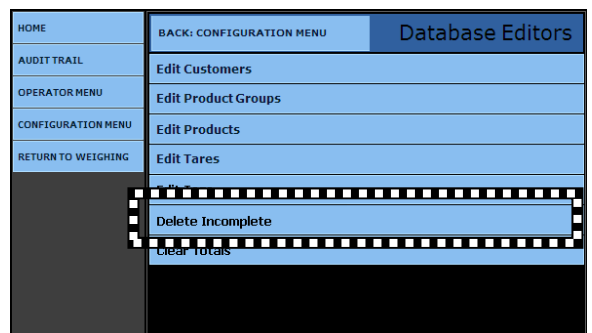

3. Select the **Incomplete Transaction** which is to be deleted by pressing the **correct DELETE** button.

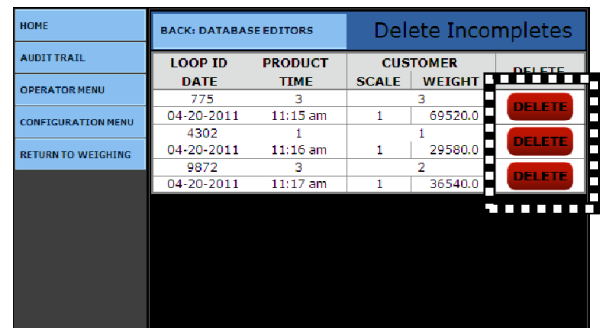

- Select **BACK: DATABASE EDITORS** to return to the previous menu.

NOTE: It is recommended to perform the **Vacuum Database** operation after deleting the transaction records.

W A R N I N G

Once deleted, the record *cannot* be recovered.

USE THIS OPERATION CAREFULLY!

7.3.7. Clear Totals

1. In the **CONFIGURATION MENU**, open the **DATABASE EDITORS** option.
2. Select the **CLEAR TOTALS** menu.
3. Click on one of the four options described below.

The **CLEAR ALL PRODUCT TOTALS** or **CLEAR ALL CUSTOMER TOTALS** options completely remove this transaction data.

- Doing this frees the stored memory space, making it available for new transaction data.
- *Most often used to update the entire database.*
- Because these options affects the entire system, including the **REPORTS** function, a **WARNING** message appears.

CLEAR PRODUCT TOTALS or **CLEAR CUSTOMER TOTALS** removes only one (1) data file per action.

- *Resets the accumulator for a single product file.*
- No warning displays for this action, as deleting an entry affects only the data associated to it.

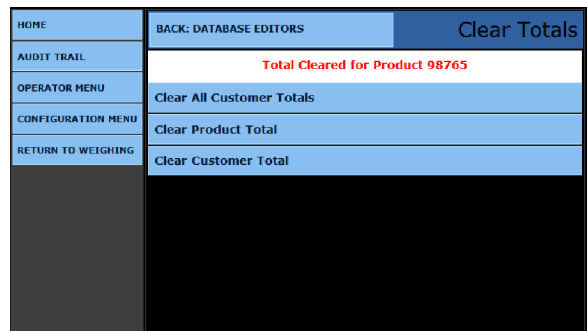
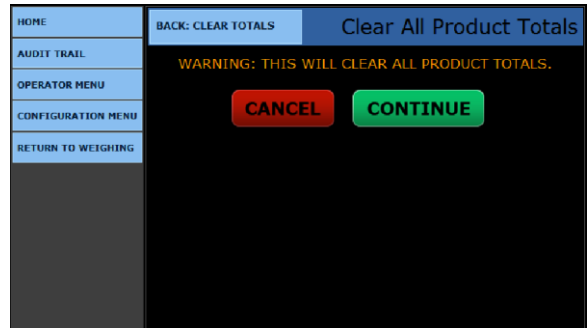
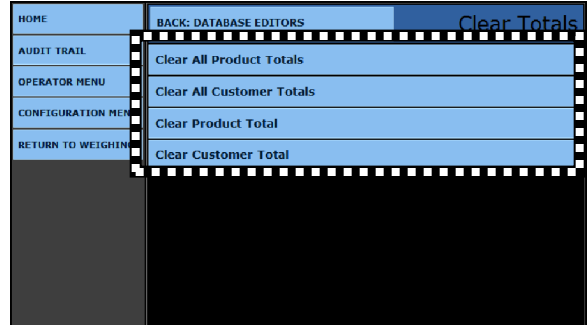
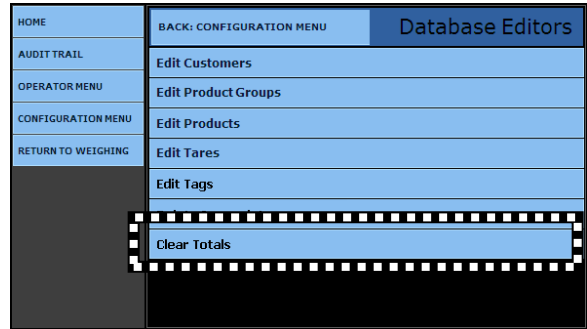

W A R N I N G

Once deleted, the record *cannot* be recovered.

USE THIS OPERATION CAREFULLY!

7.4. Reports

The FB2550 Instrument generates multiple built in reports that vary from **Master Lists** of customers, products, tares, and operators.

– These includes Transaction Reports and Summary Reports.

1. While in the **CONFIGURATION MENU**, select **REPORTS** to access the report list.

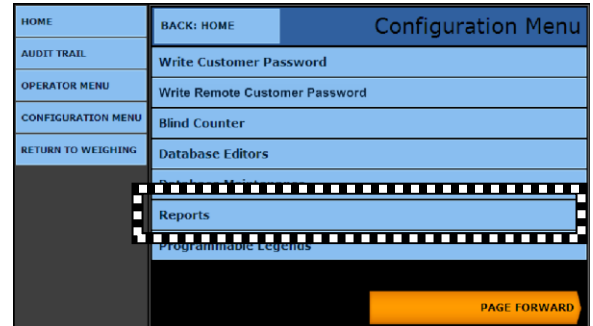

2. Select the type of report from the report list.



7.4.1. Master File Reports

The **MASTER FILE** reports are listings of all the data stored under each category available.

- Customer List
- Product List
- Product Group List
- Stored Tare List

1. Select the correct **Report** from the **MASTER FILE** lists.



7.4.1. Master File Reports, Continued

2. Press the **ACTION** button, then select the correct one.

- Email Report
- Export Report

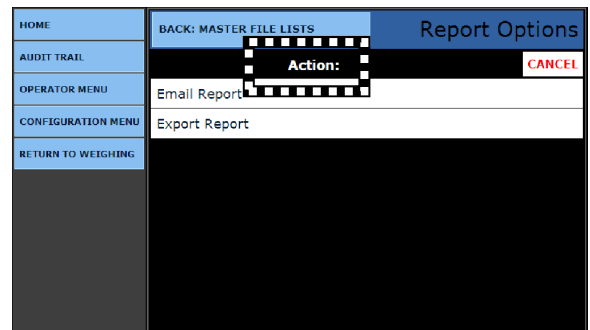
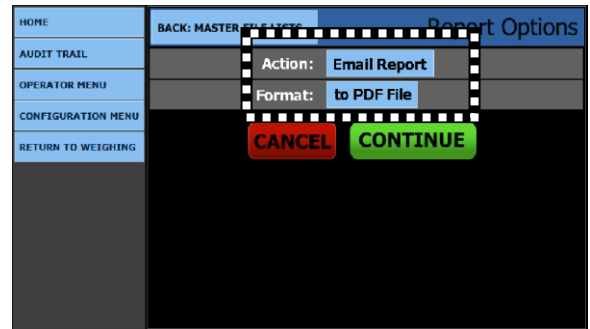

3. Press the **FORMAT** button, then select the correct one.

- To PDF File
- To CSV Text File
- To HTML File

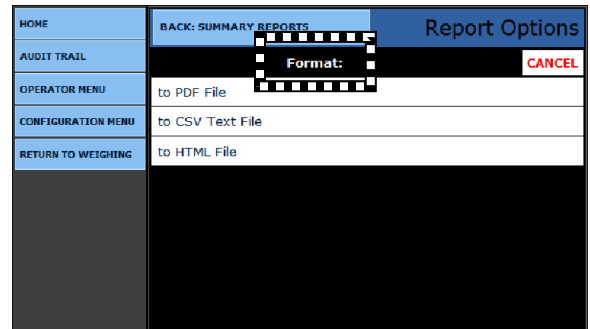

- Press the **CANCEL** button at any time to cancel the report operation.
- Press the **CONTINUE** button to begin the print operation.

*** **				
Customer Listing				
04/20/2011 - 04/20/2011				
Customer ID	Address 1	Address 2	Address 3	Address 4
1	ABC Company	123 ABC Road	Abeville, MT 09876	908-223-7765
2	Acme Consolidated Goods	7601 Plantation Ave	Plaunch, NE 76854	455-667-6521
3	XYZ Specialties	10109 NE 61st Street	Richmond, MO 64018	913-234-4260

*** **		
Product Listing		
04/20/2011 - 04/20/2011		
Product ID	Product Description	Factor
1	Coal	0.0005
3	Wheat	0.0018
2	3/4 Rock	0.0005

Shown above are two examples of Master File Reports.

7.4.2. Transaction Reports

1. While in the **CONFIGURATION MENU**, press **REPORTS** to access the report list.

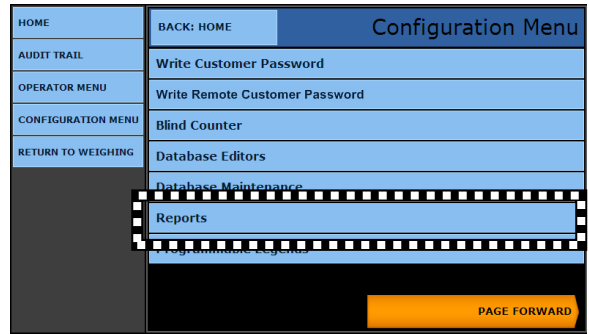

2. Select the **TRANSACTION REPORTS Menu** to choose from several reports.

- These process and use the tranation weighthment data.

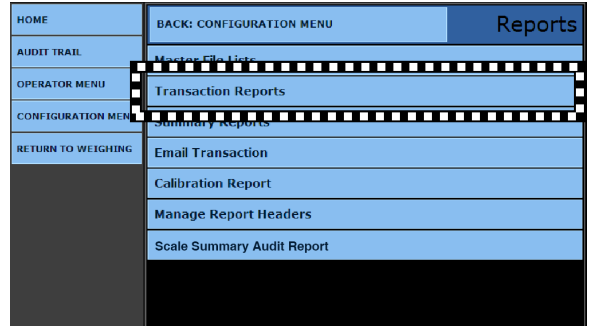

3. Select a **TRANSACTION REPORT** option from the list below.

- Completed Transactions
- Incomplete Transactions
- Report by Customer
- Scale Activity Summary
- Completed Export
- Report by Product
- Voided Transactions
- Error Report

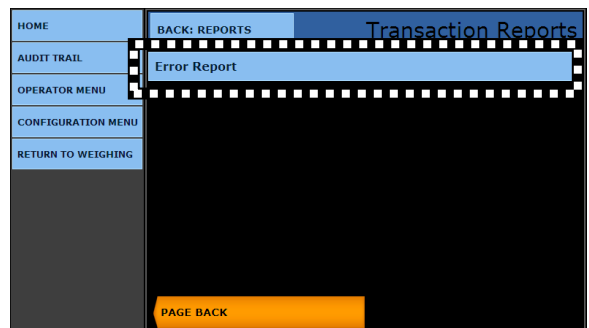
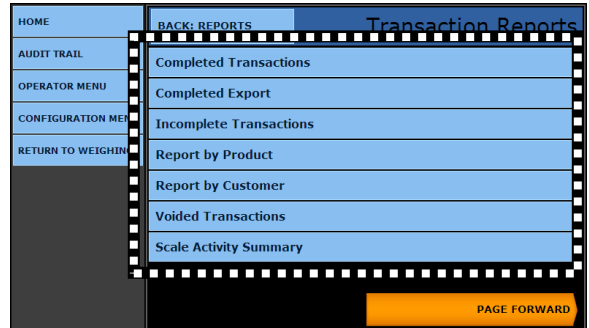

7.4.2. Transaction Reports, Continued

4. Select from the **REPORT OPTIONS MENU** for the method of printing the report.
5. Select the correct button In the **ACTION** window.

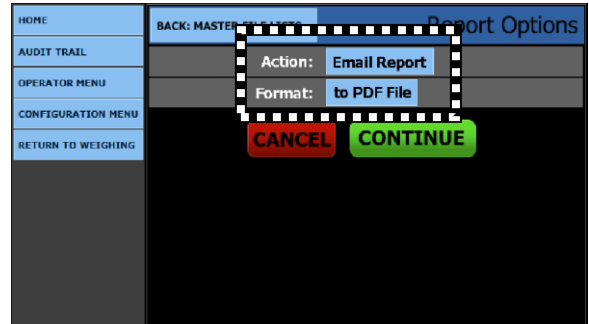

6. Select Email Report.
7. Select the correct button In the **FORMAT** window.

- To PDF File
- To CSV Text File
- To HTML File

8. Press the **CONTINUE** button to begin the print operation.
9. Press the **CANCEL** button at any time to cancel the report operation.

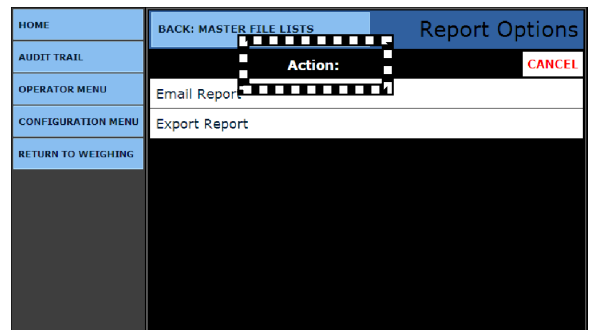

10. In the **Date Selection Menu**, set the **START YEAR, MONTH** and **DAY**.
11. Set the **END YEAR, MONTH** and **DAY**.

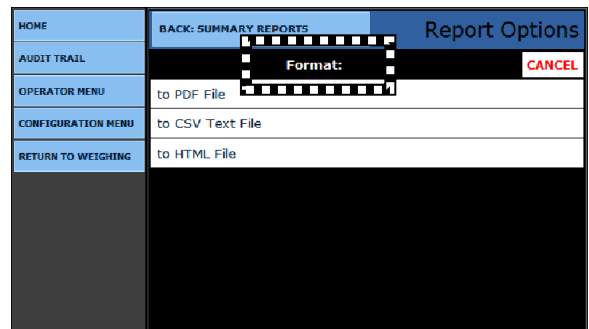

✓ **Default = CURRENT DATE**

- Press the **CONTINUE** button to begin the print operation.
- Press the **CANCEL** button at any time to cancel the report operation.
- Select **BACK: TRANSACTION REPORTS** to return to the previous menu.

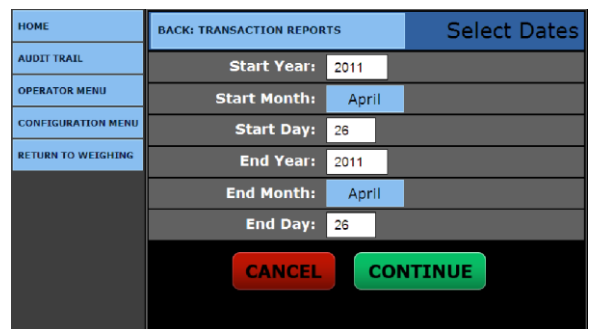

7.4.2. Transaction Reports, Continued

The **Completed Transaction Report** includes some or all of the following items.

- **Date Ranges**
- **Ticket Numbers**
- **Times and Dates of Transactions**
- **Weight Totals**

```

*** **
Completed Transactions
04/20/2011 - 04/20/2011

Transactions in lb

```

Ticket	Date	Time	Loop ID	Product ID	Customer	Gross	Tare	Net	Units
1	4/20/2011	10:42 am	1	1	1	100000.0	40000.0	60000.0	lb
2	4/20/2011	10:53 am	2	2	2	40000.0	40000.0	0.0	lb
3	4/20/2011	11:03 am	11	3	3	75740.0	20000.0	55740.0	lb
4	4/20/2011	11:04 am	22	3	3	68140.0	40000.0	28140.0	lb
5	4/20/2011	11:05 am	33	1	1	80100.0	35780.0	44320.0	lb
6	4/20/2011	11:05 am	44	2	2	77260.0	15800.0	61460.0	lb
7	4/20/2011	11:06 am	3	3	3	77240.0	20000.0	57240.0	lb
8	4/20/2011	11:07 am	4	2	3	71600.0	20000.0	51600.0	lb
Total						590060.0	231580.0	358500.0	lb

Shown above is an example of a Complete Transaction Report.

Shown to the right is an example of an **Incomplete Report**.

- **Incoming Weight**
- **Loop Numbers**
- **Product IDs**
- **Customer IDs**

```

*** **
Incomplete Transactions
04/20/2011 - 04/20/2011

```

Loop ID	Date	Time	Product ID	Customer	Inbound Wt	Units
775	04-20-2011	11:15 am	3	3	69520.0	lb
4302	04-20-2011	11:16 am	1	1	29580.0	lb
9872	04-20-2011	11:17 am	3	2	36540.0	lb

Shown above is an example of an Incomplete Transaction Report.

The **Report by Product** groups like products together and provides total weights for each product, which has been processed over the date range entered.

```

*** **
Report by Product
04/20/2011 - 04/20/2011

```

Product 1 Units lb

Product ID	Ticket	Date	Time	Loop ID	Customer	Gross	Tare	Net	Units
1	1	4/20/2011	10:42 am	1	1	100000.0	40000.0	60000.0	lb
1	5	4/20/2011	11:05 am	33	1	80100.0	35780.0	44320.0	lb
Total						180100.0	75780.0	104320.0	lb

Product 2 Units lb

Product ID	Ticket	Date	Time	Loop ID	Customer	Gross	Tare	Net	Units
2	2	4/20/2011	10:53 am	2	2	40000.0	40000.0	0.0	lb
2	6	4/20/2011	11:05 am	44	2	77260.0	15800.0	61460.0	lb
2	8	4/20/2011	11:07 am	4	3	71600.0	20000.0	51600.0	lb
Total						188860.0	75800.0	113060.0	lb

Product 3 Units lb

Product ID	Ticket	Date	Time	Loop ID	Customer	Gross	Tare	Net	Units
3	3	4/20/2011	11:03 am	11	3	75740.0	20000.0	55740.0	lb
3	4	4/20/2011	11:04 am	22	3	68140.0	40000.0	28140.0	lb
3	7	4/20/2011	11:06 am	3	3	77240.0	20000.0	57240.0	lb
Total						221120.0	80000.0	141120.0	lb

Shown above is an example of a Report by Product.

7.4.2. Transaction Reports, Continued

Like the report above, the **Report by Customer** will group like customers together and provides total weights for each customer which has been processed over the date range entered.

```

*** ***
Report by Customer
04/20/2011 - 04/20/2011

Customer 1 Units lb
Customer Ticket Date Time Loop ID Product ID Gross Tare Net Units
1 1 4/20/2011 10:42 am 1 1 100000.0 40000.0 60000.0 lb
1 5 4/20/2011 11:05 am 33 1 801000.0 35780.0 443220.0 lb
Total 1801000.0 75780.0 1043220.0 lb

Customer 2 Units lb
Customer Ticket Date Time Loop ID Product ID Gross Tare Net Units
2 2 4/20/2011 10:53 am 2 2 40000.0 40000.0 0.0 lb
2 6 4/20/2011 11:05 am 44 2 77260.0 15800.0 61460.0 lb
Total 117260.0 55800.0 61460.0 lb

Customer 3 Units lb
Customer Ticket Date Time Loop ID Product ID Gross Tare Net Units
3 3 4/20/2011 11:03 am 11 3 75740.0 20000.0 55740.0 lb
3 4 4/20/2011 11:04 am 22 3 68140.0 40000.0 28140.0 lb
3 7 4/20/2011 11:06 am 3 3 77240.0 20000.0 57240.0 lb
3 8 4/20/2011 11:07 am 4 2 71600.0 20000.0 51600.0 lb
Total 292720.0 100000.0 192720.0 lb

```

*Shown above is an example of a **Report by Customer**.*

The **Voided Transactions** report lists all transactions which have been voided over the date range entered.

```

*** ***
Voided Transactions
04/20/2011 - 04/20/2011

Transactions in lb
Ticket Loop ID Product ID Customer Gross Tare Net Units
2 2 2 2 40000.0 40000.0 0.0 lb
Total 40000.0 40000.0 0.0 lb

```

*Shown above is an example of a **Voided Transactions**.*

The **Scale Activity Summary**, or **Blind Counter Report** lists the number of weighments which have exceeded the Threshold setting.

- **No tickets are produced and the transaction is not stored or saved.**

```

*** ***
Scale Activity Report
04/20/2011 - 04/20/2011

Scale Blind Counts
Scale 1 0
Scale 2 0
Scale 3 0
Scale 4 0
Scale 5 0
Scale 6 0
Scale 7 0
Scale 8 0

```

*Shown above is an example of a **Scale Activity Report**.*

7.4.2. Transaction Reports, Continued

The **Error Report** lists all of the errors which have occurred in the operation of the instrument.

- It details the specifics of each error code and the error parameters.
- The report also details if the error is enabled for reporting. The last occurrence details the time and date the error occurred.

*** **						
Error Report						
04/20/2011 - 04/20/2011						
Error Code	Description	Parameter 1	Parameter 2	Recipients	Last Occurrence	Enabled?
BC1	BLIND COUNTER INCREMENT	SCALE	COUNT	*	Thu Mar 10 15:03:43 - 0500 2011	true
CCB	CONFIG / CALIB NEEDS BACKUP				Wed Apr 20 10:39:39 - 0400 2011	true
CME	CELL MOTION ERROR	CELL			Fri Mar 11 00:00:00 - 0500 2011	true
CWF	CALIBRATION	CELL			Fri Mar 11 00:00:00 - 0500 2011	true

Shown above is an example of an Error Report.

7.4.3. Summary Reports

1. While in the **CONFIGURATION MENU**, select the **SUMMARY REPORTS** for a general summary of transaction activities for customers or products.

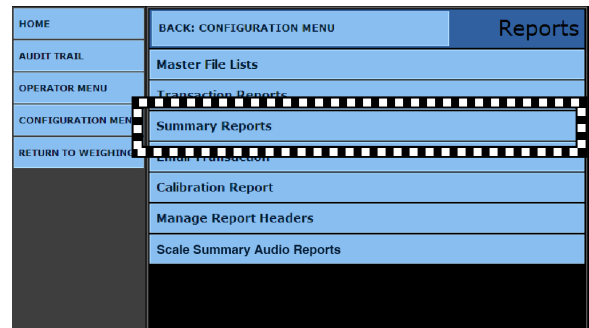

2. Select whether the Report is **BY CUSTOMER** or **BY PRODUCT**.



3. Select from the **REPORT OPTIONS MENU** for the method of printing the report.

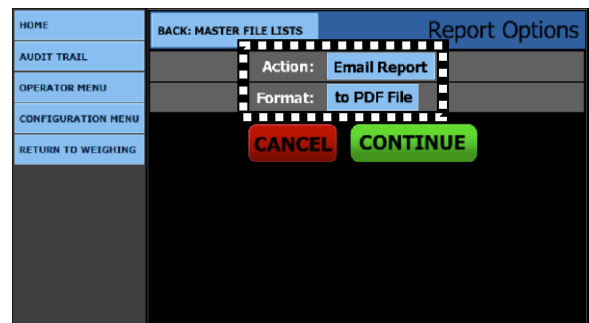

7.4.3. Summary Reports, Continued

4. Select the correct button In the **ACTION** window.

- Email Report
- Export Report

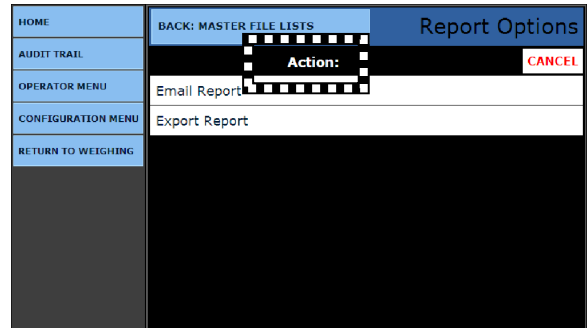

5. Select the correct button In the **FORMAT** window.

- To PDF File
- To CSV Text File
- To HTML File

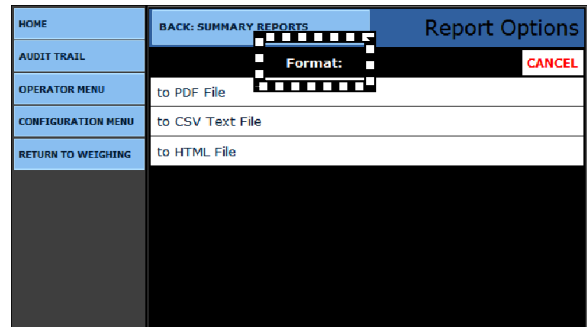

6. Select the appropriate **Date Range** for the report.

- The default values will be the current date.

7. Press the **CONTINUE** button to process the report.

8. Selecting the **CANCEL** button will abort the process.

- Select **BACK: HOME** to return to the Home Menu.

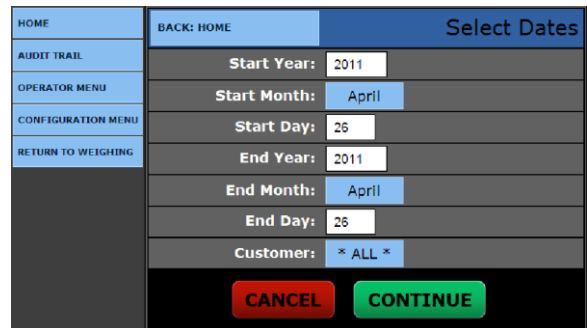

*** **			
Summary Customer			
04/20/2011 - 04/20/2011			
Customer	Total Transactions	Total Weight	Units
1	2	180100.0	1b
2	1	77260.0	1b
3	4	292720.0	1b

Shown above is an example of a **Customer Summary Report**.

*** **			
Summary Product			
04/20/2011 - 04/20/2011			
Product ID	Total Transactions	Total Weight	Units
1	2	180100.0	1b
2	2	148860.0	1b
3	3	221120.0	1b

Shown above is an example of a **Product Summary Report**.

7.4.4. Email Transaction

The **EMAIL TRANSACTION** sends an email to a **maximum of three (3) recipients**, which contains **one (1) Transaction Record**.

1. While in the **CONFIGURATION MENU**, press **REPORTS**.

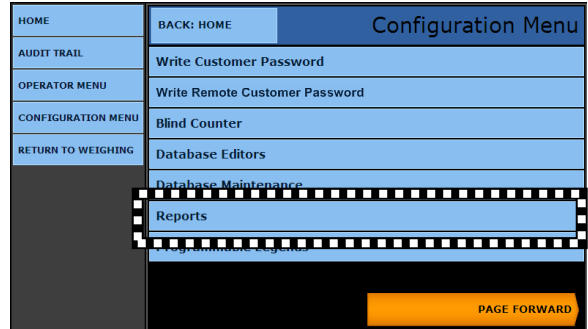

2. Select the **EMAIL TRANSACTION**.

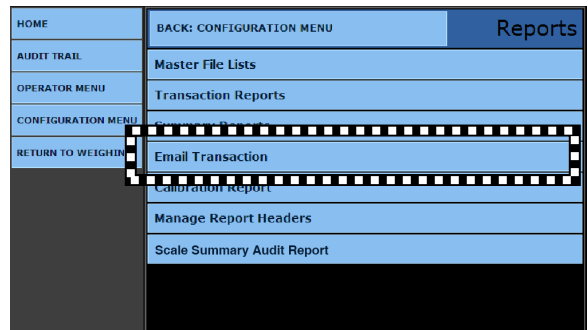

3. Enter the valid **TICKET NUMBER** to open a **Transaction Record**.
4. In the **Recipient 1, 2 and 3** fields, enter the correct **EMAIL ADDRESSES**.

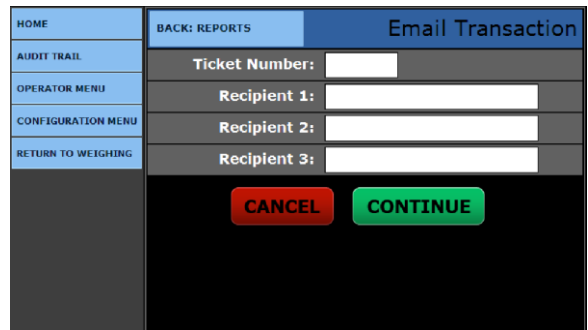

- Press the **CANCEL** button to abort the process
- Press the **CONTINUE** button to process the report.
- Select **BACK: REPORTS** to return to the **Reports Menu**.

7.4.5. Scale Summary Audit Report

The **Scale Summary Audit Report** lists all the transactions individually for each type of weighment.

- While in the **CONFIGURATION MENU**, select the **SCALE SUMMARY AUDIT REPORT**.

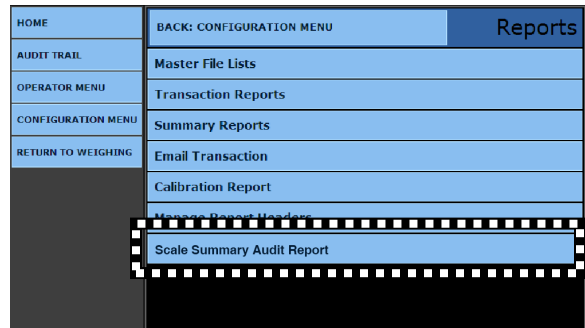

- Select the correct button In the **ACTION** window.

- Email Report
- Export Report

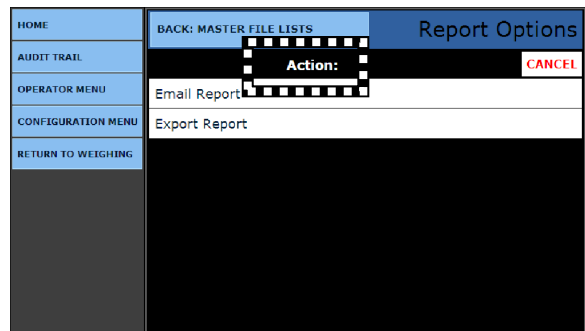

- Select the correct button In the **FORMAT** window.

- To PDF File
- To CSV Text File
- To HTML File

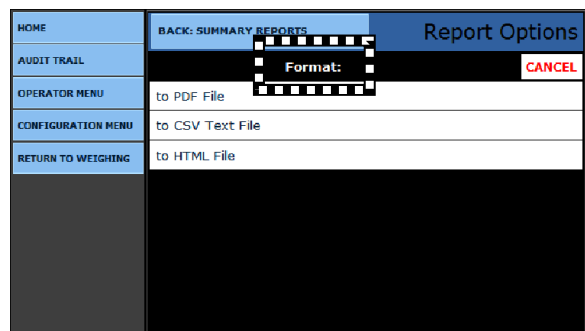

A processing message appears.

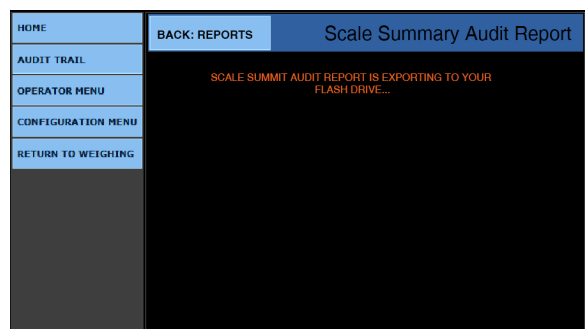



7.4.5. Scale Summary Audit Report, Continued

Shown below is an example of a **Scale Summary Audit Report** for one day's weighments.

*** **				
Scale Summary Audit Report				
	Transactions	Fee \$	Total Amount	Time Stamp
Weigh	102	\$8.00	\$816.00	11:37PM 08/28/2014
Reweigh	4	\$4.00	\$16.00	11:37PM 08/28/2014
Double	5	\$12.00	\$60.00	11:37PM 08/28/2014
Reweigh Double	2	\$6.00	\$12.00	11:37PM 08/28/2014
Triple	0	\$15.00	\$0.00	11:37PM 08/28/2014
Reweigh Triple	0	\$8.00	\$0.00	11:37PM 08/28/2014
No Fee	0	\$0.00	\$0.00	11:37PM 08/28/2014
Total	0		\$904.00	
Blind Counter Scale 1	0			

SECTION 8: INPUT/ OUTPUT

8.1. Printers

The FB2550 instrument has **three (3) standard Serial Output Ports** which are configured for RS-232 communications.

- Additional serial outputs such as **RS-232, 20mA**, and **RS-485** are available as optional accessories.

NOTE: For solutions, see [Section 10.2. Printer Troubleshooting](#).

8.1.1. Printer Switch Settings

TAPE PRINTER	SW 1 ON	SW 2 ON	SW 3 ON	SWITCH SETTINGS
iDP3550 (SER)	2, 3, 4, 8	1, 2, 3, 5, 6	—	9600 Baud, No Parity, 8 Data and 1 Stop Bit
* TM-U220 (White) (SER)	All OFF	All OFF	—	9600 Baud, No Parity, 8 Data and 1 Stop Bit
TM-U230/U220 (Dk GRay) DAT (SER)	All OFF	2, 5, 8	—	9600 Baud, No Parity, 8 Data and 1 Stop Bit
SP700 (SER)	1 thru 7	1 thru 6	1, 5	9600 Baud, No Parity, 8 Data and 1 Stop Bit

REPORT PRINTER	SW 1 ON	SW 2 ON	SW 3 ON	SWITCH SETTINGS
OKI ML420 (USB)	—	—	—	N/A
XEROX 3040 (USB)	—	—	—	N/A

TICKET PRINTER	SW 1 ON	SW 2 ON	SW 3 ON	SWITCH SETTINGS
TM-U590 (SER)	1, 3, 7	All OFF	—	9600 Baud, No Parity, 8 Data and 1 Stop Bit
TM-U295 (SER)	1, 3	All OFF	—	9600 Baud, No Parity, 8 Data and 1 Stop Bit
SP298 (SER)	All OFF	3	1, 5	9600 Baud, No Parity, 8 Data and 1 Stop Bit
SP2000 (SER)	All OFF	3	1, 5	2400 Baud, Even Parity, 7 Data and 2 Stop Bit
SP2200 (SER)	2, 3, 8	All OFF	All OFF	2400 Baud, No Parity, 7 Data and 2 Stop Bit
OKI ML420 (SER)	—	—	—	9600 Baud, No Parity, 8 Data and 1 Stop Bit

* Replaces the **IDP 3550**.

Fairbanks printer **default settings** are noted in the chart to the right.

- Use **USB Cable (29827C)**, as needed.
- FB2550 Desktop and NEMA 4X use **Serial Cable (25932)**.

BAUD	9600
PARITY	None
DATA BITS	8
STOP BIT	1

8.1.2. iDP3550 Tape Printer

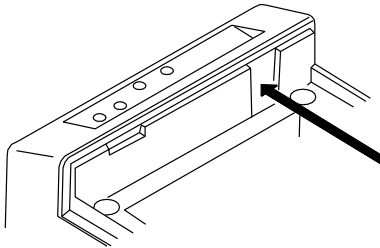

DS2	ON	OFF	DS1	ON	OFF
1	X		1		X
2	X		2	X	
3	X		3	X	
4		X	4	X	
5	X		5		X
6	X		6		X
7		X	7		X
8		X	8	X	
			9		X
			10		X

BAUD	9600
PARITY	No
DATA BITS	8
STOP BIT	1

Cable **25932** Wiring for COM 1-3

DB-9 INSTRUMENT	DESCRIPTION	WIRE COLOR	DB-25 PRINTER	DESCRIPTION
2	RxD	BR	2	TxD
3	TxD	R	3	RxD
4	DRT	O	6	DSR
5	SG	Y	7	SG
6	DSR	G	20	DTR
7	RTS	BL	5	CTS
8	CTS	BK	4	RTS

Cable **25932** Wiring for Serial Expansion Module*

RS232 PORT 1: COM XX	DESCRIPTION	WIRE COLOR	DB-25 PRINTER	DESCRIPTION
TB1a-2	RxD	BR	2	TxD
TB1a-3	TxD	R	3	RxD
TB1a-4	DRT	O	6	DSR
TB1a-5	SG	Y	7	SG
TB1b-6	DSR	G	20	DTR
TB1b-7	RTS	BL	5	CTS
TB1b-8	CTS	BK	4	RTS

* Must remove the 9-pin connector.

8.1.3. TM-U220 Tape Printer

The **TM-U220 Tape Printer** is the primary default printer for standard configurations with the FB2550 Instrument.

- It uses **SERIAL** communication.
- Necessary cable used is **25932**.

BAUD	9600
PARITY	No
DATA BITS	8
STOP BIT	1

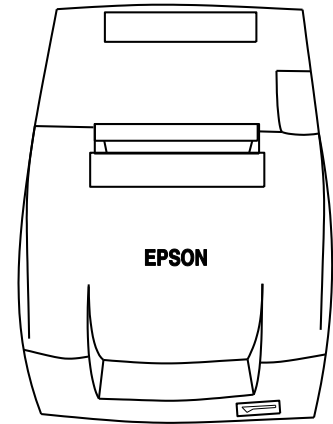

WIRING

Cable **25932** Wiring for COM 1-3

DB-9 INSTRUMENT	DESCRIPTION	WIRE COLOR	DB-25 PRINTER	DESCRIPTION
2	RxD	BR	2	TxD
3	TxD	R	3	RxD
4	DRT	O	6	DSR
5	SG	Y	7	SG
6	DSR	G	20	DTR
7	RTS	BL	5	CTS
8	CTS	BK	4	RTS

Cable **25932** Wiring for Serial Expansion Module*

RS232 PORT 1: COM7 XX	DESCRIPTION	WIRE COLOR	DB-25 PRINTER	DESCRIPTION
TB1a-2	RxD	BR	2	TxD
TB1a-3	TxD	R	3	RxD
TB1a-4	DRT	O	6	DSR
TB1a-5	SG	Y	7	SG
TB1b-6	DSR	G	20	DTR
TB1b-7	RTS	BL	5	CTS
TB1b-8	CTS	BK	4	RTS

* *Must remove the 9-pin connector.*

8.1.3. TM-U220 Tape Printer s, Continued

DIP SWITCH 1 (Serial Interface)

SWITCH	FUNCTION	ON	OFF
1	Data receive error	Ignored	Prints “?”
2	Receive buffer capacity	40 bytes	4KB
3	Handshaking	XON/XOFF	DTR/DSR
4	Work length	7 bits	8 bits
5	Parity check	Yes	No
6	Parity selection	Even	Odd
7	Transmission speed	4800 bps	9600 bps
8	BUSY condition	Receive buffer full	Receive buffer full or Offline

DIP SWITCH 2 (Serial Interface)

SWITCH	FUNCTION	ON	OFF
1	Print Column	42/35	40/33
2	For internal use only (auto-cutter) (do not change)	Enabled	Disabled
3	Pin 6 reset signal	Used	Not used
4	Pin 25 reset signal	Used	Not used
5	Undefined	--	--
6	Internal use only (flash memory rewriting) (Do not change)	Enabled	Disabled
7	Undefined	--	--
8	Serial Interface section	Memory Switch	Dip Switch

Access the **Dip Switches** by unfastening the screw and removing the cover plate, found on the bottom of the printer.

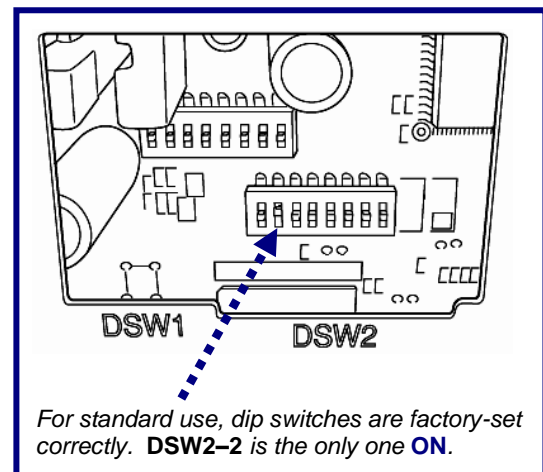

8.1.4. SP700 Tape Printer

- For FB2550 Instrument communications, use cable **25932**.

BAUD	9600
PARITY	No
DATA BITS	8
STOP BIT	1

There are two (2) dip switch locations on the **Star SP700 Printer**.

- Underneath the printer, behind a protective cover is **DIP SWITCH 1**.
- DIP SWITCH 2** is on the **Serial Interface Board**.

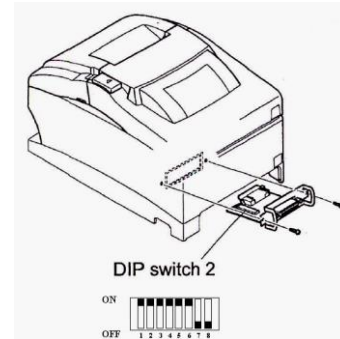
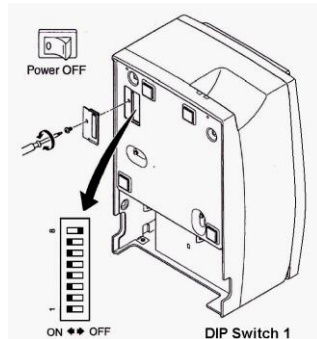

DIP Switch 1

SWITCH	FUNCTION	ON	OFF
1-1	Always ON	Should be set ON	
1-2	Auto Cutter *	Invalid	Valid
1-3	Always ON	Should be set ON	
1-4	Command Emulation	Star	ESC/POS
1-5	USB mode **	Printer Class	Vendor Class
1-6	2 Colors Printing	Valid	Invalid
1-7	Reserved		
1-8	Print head model ***	18-pin wire	9-pin wire

* The factory settings for enabling/disabling the **Auto Cutter** are as listed below.

- Models without Auto Cutter: Invalid (**Switch 1-2 = ON**).
- Models with Auto Cutter: Valid (**Switch 1-2 = OFF**)

NOTE: Do not enable the **AUTO CUTTER** for models without this feature.

A mechanical error will occur.

** **USB Interface** model only.

*** Do not change the default setting (**Switch 1-8 = OFF**).

8.1.4. SP700 Tape Printer, Continued

DIP Switch 2

SWITCH	FUNCTION	ON	OFF
2-1	Baud Rate	<i>See table below.</i>	
2-2			
2-3	Data Length	8 bits	7 bits
2-4	Parity Check	Disabled	Enabled
2-5	Parity	Odd	Even
2-6	Handshake	DTR/DSR	XON/XOFF
2-7	Pin #6 (DSR) reset signal	Valid	Invalid
2-8	Pin #25 (INIT) reset signal	Valid	Invalid

Baud Rate Settings Table

BAUD RATE	SWITCH 2-1	SWITCH 2-2
4800 bps	OFF	ON
9600 bps	ON	ON
1920 bps	ON	OFF
3840 bps	OFF	OFF

8.1.5. OKI ML420 Report Printer

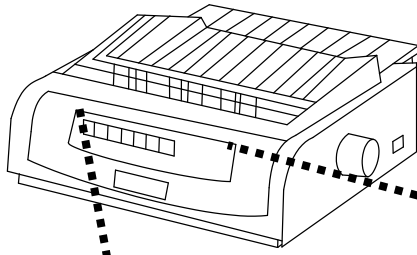

BAUD	9600
PARITY	None
DATA BITS	8
STOP BIT	1

SEL						
SEL		LF	FF/LOAD	TEAR	PARK	QUIET
MENU	SHIFT	Micro Feed Down	Micro Feed Up			TOF
EXIT		GROUP	ITEM	SET	PRINT	
POWER	ALARM		MENU			

- For FB2550 Instrument communications, use cable **25932** or **14807**.
- For **USB** input, use cable **29827C**.

CABLE 26041 WIRING for Serial Expansion Module *

RS232 Port 1: COM XX	RS232 Port 2: COM XX	RS232 Port 3: COM XX	Description	DB-25 Printer
TB1a-3	TB1b-5	TB1d-2	Transmit (Tx)	3
TB1a-2	TB1c-1	TB1d-3	Receive (Rx)	2
TB1a-5	TB1c-2	TB1d-4	Ground (GND)	7

- **All** printer settings apply to both the **Serial** and **USB** models.

Cable **25932** Wiring for Serial Expansion Module*

RS232 PORT 1: COM7 XX	DESCRIPTION	WIRE COLOR	DB-25 PRINTER	DESCRIPTION
TB1a-2	RxD	BR	2	TxD
TB1a-3	TxD	R	3	RxD
TB1a-4	DRT	O	6	DSR
TB1a-5	SG	Y	7	SG
TB1b-6	DSR	G	20	DTR
TB1b-7	RTS	BL	5	CTS
TB1b-8	CTS	BK	4	RTS

* *Must remove the 9-pin connector.*

NOTE: The **Okidata ML420** is used as both a Report Printer and a Ticket Printer.

- As a **USB Printer**, there is no need to adjust the Switch Settings.

8.1.5. OKI ML420 Report Printer, Continued

Follow these steps to change **MENU** settings on the Printer.

1. To enter **MENU MODE**, press and hold the **SHIFT** key while pressing the **SELECT** key.
 - The “**MENU**” legend will be illuminated.
2. With the printer in the **MENU MODE**, press the **PRINT** key
 - This prints all the programming options in the **MENU MODE**, as well as the current default settings.
 - It is recommended to use tractor fed paper.
 - ***The printed menu selections are different for each Emulation Mode.***
3. Press the **GROUP** key to select the relevant **Group** that needs to be changed.
4. Press the **ITEM** key to select the relevant **Item** within the selected group.
5. Press the **SET** key to cycle through all the **Settings** available
6. Press and hold the **SHIFT** + **SELECT** keys to exit the **MENU MODE**.

NOTE: *Turning off the printer before exiting the **MENU MODE** will lose any changes made.*

PRINTER SETTINGS

GROUP (Press LINE FEED to change)	ITEM (Press FORM FEED to change)	SET (Press TOF SET to change)
Printer Control	Emulation Mode	IBM PPR
Font	Print Mode	Utility
Font	DRAFT Mode	HSD
Font	Pitch	10 CPI
Font	Proportional Spacing	No
Font	Style	Normal
Font	Size	Single
Symbol Sets	Character Set	Set 1
Symbol Sets	Language Set	American
Symbol Sets	Zero Character	Slashed
Symbol Sets	Code Page	USA



8.1.5. OKI ML420 Report Printer, Continued

GROUP (Press LINE FEED to change)	ITEM (Press FORM FEED to change)	SET (Press TOF SET to change)
Printer Control	Emulation Mode	IBM PPR
Rear Feed	Line Spacing	6 LPI
Rear Feed	Form Tear-off	Off
Rear Feed	Skip Over Perforation	No
Rear Feed	Page Length	11"
Bottom Feed	Line Spacing	6 LPI
Bottom Feed	Form Tear-off	Off
Bottom Feed	Skip Over Perforation	No
Bottom Feed	Page Length	11"
Top Feed	Line Spacing	6 LPI
Top Feed	Form Tear-off	Off
Top Feed	Skip Over Perforation	No
Top Feed	Page Length	11"
Set-Up	Graphics	Bi-directional
Set-Up	Receive Buffer Size	64K
Set-Up	Paper Out Override	No
Set-Up	Print Registration	0
Set-Up	Operator Panel Function	Full Operation
Set-Up	Reset Inhibit	No
Set-Up	Print Suppress Effective	Yes
Set-Up	Auto LF	No
Set-Up	Auto Select	No
Set-Up	SI Select Pitch (10CP)	17.1 CPI
Set-Up	SI Select Pitch (12CPI)	12 CPI
Set-Up	Time Out Print	Valid
Set-Up	Auto Select	No
Set-Up	Centering Position	DEFAULT
Set-Up	ESC SI Pitch	17.1 CPI
Set-Up	Power Saving	Disable
Set-Up	Power Save Time	5 Min
Parallel I/F	I-Prime	Buffer Print
Parallel I/F	Pin 18	+5v
Parallel I/F	Bi-Direction	Enable



8.1.5. OKI ML420 Report Printer, Continued

GROUP (Press LINE FEED to change)	ITEM (Press FORM FEED to change)	SET (Press TOF SET to change)
Printer Control	Emulation Mode	IBM PPR
Serial I/F	Parity	None
Serial I/F	Serial Data 7/8 Bits	8 Bits
Serial I/F	Protocol	X-On/X-Off
Serial I/F	Diagnostic Test	No
Serial I/F	Busy Line	SSD-
Serial I/F	Baud Rate	9600 BPS
Serial I/F	DSR Signal	Invalid
Serial I/F	DTR Signal	Ready on Pwr up
Serial I/F	Busy Time	200 ms

8.1.6. XEROX® Phaser 3040 Report Printer

The **XEROX® Phaser 3040** is a **USB only** Report Printer.

- Plug-and-play device.
- Use **USB Cable (29827C)**.

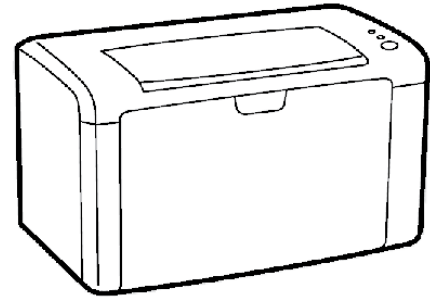

PRINTER SPECIFICATIONS

Print Speed	Up to 24 ppm
Resolution	<ul style="list-style-type: none"> • 600 x 600 dpi • 1200 x 1200 dpi
Paper Capacity	<ul style="list-style-type: none"> • 150-sheet main tray • 100-sheet output tray
Maximum Print Size	8.5 x 14 in.
Connectivity	USB 2.0
Dimensions	22"(w) x 32.6"(d) x 15.1"(h)
Optimum Temperature	50-90° F
Optimum Humidity Range *	15-85%
Power Supply Voltage and Frequency	<ul style="list-style-type: none"> • 110-127 VAC; 50/60 Hz (+/- 3 Hz) • 220-240 VAC, 50/60 Hz (+/- 3 Hz)
Printer Warm-up Time	<ul style="list-style-type: none"> • Power on in 25 seconds or less. • Recovery from Sleep Mode in 25 seconds or less.
Processor	150 MHz 4305 Processor
Memory	64MB Standard Memory

* Defects can occur due to condensation.

8.1.6. XEROX® 3040 Report Printer, Continued

LOADING PAPER IN THE MAIN TRAY

1. Open the front cover.
2. Pull the slide bar forward until it stops.
3. Pull the length guide forward until it stops.
4. Move the width guides to the edges of the tray.
5. Flex the paper sheets back and forth and fan them, then align the edges of the stack on a level surface.
 - Doing this reduces the possibility of jams.
6. Load the paper into the tray, top edge toward the printer and the print side up.
7. Adjust the width guides until they touch the edges of the paper.
8. Push in the length guides and slide bar until they stop.
9. Place the paper cover on the main tray and align the tabs with the marks on the tray.

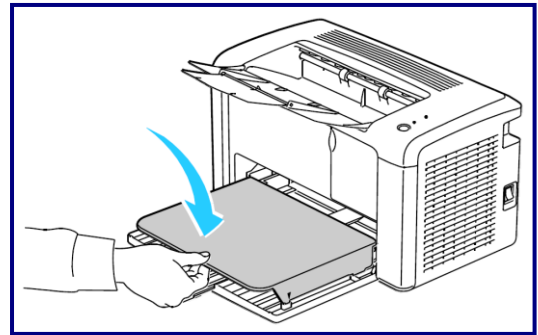
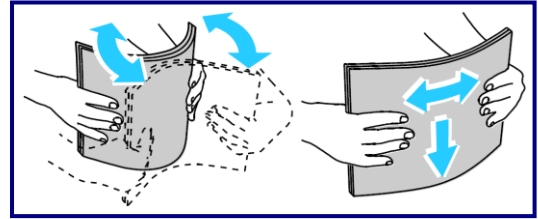

TONER/PAPER OUT WARNINGS

It is time to order supplies when the printer Control Panel displays a message.

- To avoid interruptions of printing, order replacement supplies when the messages first appears as a warning.
- When the toner cartridge needs replacing, the control panel Instruments light up and display a message.

8.1.7. TM-U590 Ticket Printer

- For FB2550 Instrument communications, use cable **25932**.

BAUD	9600
PARITY	No
DATA BITS	8
STOP BIT	1

Set the printer **dip switches** as listed below.

DSW 1: 1, 3, and 7 = **ON** only.

DSW 2: All Switches = **OFF**

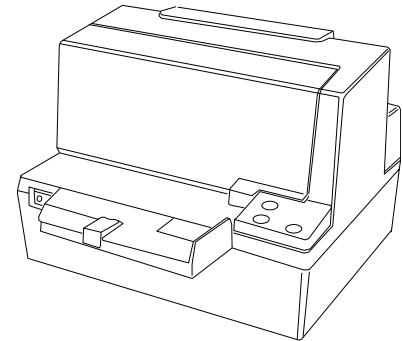

Cable **25932** Wiring for COM 1-3

DB-9 INSTRUMENT	DESCRIPTION	WIRE COLOR	DB-25 PRINTER	DESCRIPTION
2	RxD	BR	2	TxD
3	TxD	R	3	RxD
4	DRT	O	6	DSR
5	SG	Y	7	SG
6	DSR	G	20	DTR
7	RTS	BL	5	CTS
8	CTS	BK	4	RTS

Cable **25932** Wiring for Serial Expansion Module*

RS232 PORT 1: COM7 XX	DESCRIPTION	WIRE COLOR	DB-25 PRINTER	DESCRIPTION
TB1a-2	RxD	BR	2	TxD
TB1a-3	TxD	R	3	RxD
TB1a-4	DRT	O	6	DSR
TB1a-5	SG	Y	7	SG
TB1b-6	DSR	G	20	DTR
TB1b-7	RTS	BL	5	CTS
TB1b-8	CTS	BK	4	RTS

* Must remove the **9-pin connector**.

8.1.8. TM-U295 Ticket Printer

- For FB2550 Instrument communications, use cable **25932**.

BAUD	9600
PARITY	No
DATA BITS	8
STOP BIT	1

Set the printer **dip switches** as listed below.

- SW1: 1 and 3 = ON**
- Remainder = OFF**

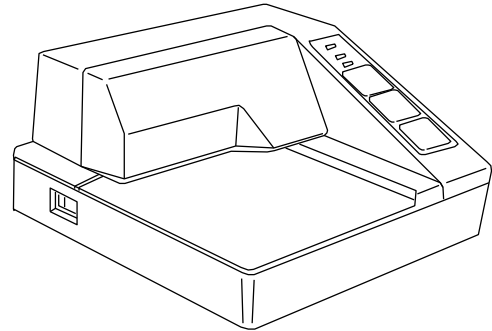

Cable **25932** Wiring for COM 1-3

DB-9 INSTRUMENT	DESCRIPTION	WIRE COLOR	DB-25 PRINTER	DESCRIPTION
2	RxD	BR	2	TxD
3	TxD	R	3	RxD
4	DRT	O	6	DSR
5	SG	Y	7	SG
6	DSR	G	20	DTR
7	RTS	BL	5	CTS
8	CTS	BK	4	RTS

Cable **25932** Wiring for Serial Expansion Module*

RS232 PORT 1: COM7 XX	DESCRIPTION	WIRE COLOR	DB-25 PRINTER	DESCRIPTION
TB1a-2	RxD	BR	2	TxD
TB1a-3	TxD	R	3	RxD
TB1a-4	DRT	O	6	DSR
TB1a-5	SG	Y	7	SG
TB1b-6	DSR	G	20	DTR
TB1b-7	RTS	BL	5	CTS
TB1b-8	CTS	BK	4	RTS

*
Must remove the 9-pin connector.

8.1.9. SP298 Ticket Printer

- For FB2550 Instrument communications, use cable **25932**.

BAUD	9600
PARITY	No
DATA BITS	8
STOP BIT	1

ACCESSING THE DIP SWITCHES

- Remove all power from the printer**, as well as all Network cables from between the printer and the Instrument.
- Remove the **PRINTER COVER**.
- Press down with a screwdriver at **LOCATION "A"** marked in the illustration below, and carefully slide the **Document Table** in the direction indicated by the arrow until it is out of the way.
 - It is not necessary to remove the document table completely. Just move it enough to access the DIP Switches inside.
- Set the **DIP SWITCHES** into their correct positions.
- Slide the Document Table back into place while pressing down at **LOCATION "A"**.
- Replace the **PRINT COVER**.

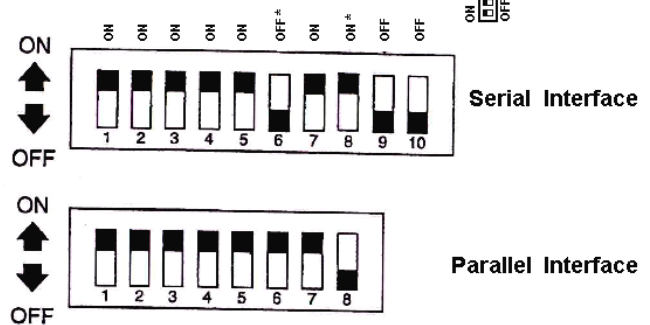
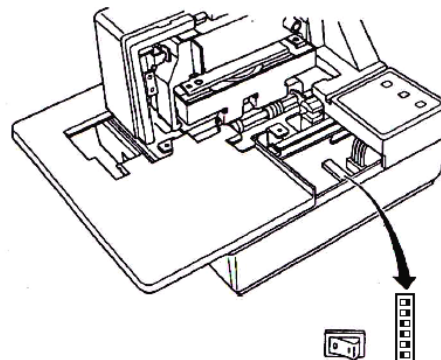
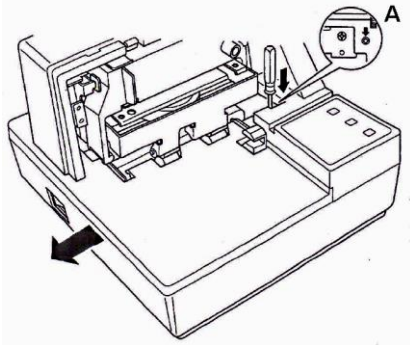

* Changed from the default settings.

8.1.9. SP298 Ticket Printer, Continued

DIP Switch Settings (**SERIAL INTERFACE**)

SWITCH	FUNCTION	ON	OFF
1	Baud Rate	<i>See table below.</i>	
2			
3	Data Length	8 bits	7 bits
4	Parity Check	Disabled	Enabled
5	Parity	Odd	Even
6	Handshake	DTR/DSR	XON/XOFF
7	Command Emulation	<i>See table below</i>	
8			
9	Pin #6 (DSR) reset signal	Enabled	Disabled
10	Pin #25 (INIT) reset signal	Enabled	Disabled

Baud Rate Settings Table

BAUD RATE	SWITCH 1	SWITCH 2-2
4800 bps	OFF	ON
9600 bps	ON	ON
1920 bps	ON	OFF
3840 bps	OFF	OFF

Command Emulation Table

COMMAND EMULATION	SWITCH 7	SWITCH 8
Star Mode	ON	ON
ESC/POS (TM-295)	ON	OFF
ESC/POS (TM-290)	OFF	OFF
Not used (*)	OFF	ON

* Never set **Switch 7** to **OFF** at the same time that **Switch 8** is set to **ON**.

8.1.10.SP2000 Ticket Printer

The SP2000 is a Dot Matrix ticket printer. The following switch settings and cable requirements will work with the default format.

- For FB2550 Instrument communications, use cable **25932**.

Noted below are the **dip switch** and **default settings**.

- **DSW 1:** All **OFF**.
- **DSW 2:** Three (3) **ON** only.
- **DSW 3:** One (1), and five (5) **ON** only.

BAUD	2400
PARITY	EVEN
DATA BITS	7
STOP BIT	1

8.1.11.SP2200 Ticket Printer

The SP2200 is a Dot Matrix ticket printer. The following switch settings and cable requirements will work with the default format.

- For FB2550 Instrument communications, use cable **25932**.

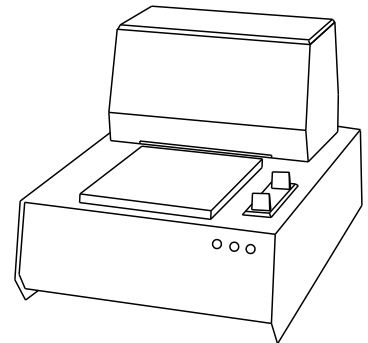

STANDARD TICKET CONFIGURATIONS

Noted below are the **dip switch** and **default settings**.

- **DSW 1:** Two (2), three (3), and eight (8) **ON** only.
- **DSW 2 and 3:** All **OFF**.

BAUD	2400
PARITY	NO
DATA BITS	7
STOP BIT	2

INVERTED TICKET CONFIGURATIONS

To invert the print on an SP2200, switch settings are different, and must be changed.

- The printer does not invert using the software command, like with some other printers.

Set the printer's dip switches **DSW 1 four (4), five (5) and six (6)** according this chart.

Normal Print	Off	Off	Off
Inverted	Off	Off	ON
2x Width	Off	ON	Off
2xHeight	Off	ON	ON
2x Height Inverted	ON	Off	Off
2x Width Inverted	ON	Off	ON
2x Width and 2x Height	ON	ON	Off
2x Width and 2x Height Inverted	ON	ON	ON

8.1.12. Programming the Printers

The two printer interface types on the FB2550 are **USB** and **Serial**.

Serial Printers must be configured manually.

- Dip switches must be set up correctly or they will not transmit and print the data.
- Print drivers are sometimes needed to set up communications.

USB Printers are considered “plug-and-play”, as the parameter defaults are automatically programmed.

- There are no dip switches or drivers needed for these printers.

IMPORTANT NOTE: For **SERIAL PRINTERS**, do not plug the printer into the Instrument if either is powered-up and running. ***This can damage the I/O Board.***

8.1.13. Serial Printer Programming

Follow these steps to configure the **Serial Printer** connected to the **FB2550 Instrument**.

1. Plug the printer into one of the Instrument's **Serial Ports**.
2. Turn on both components.
3. Press the **MENU** Button.
4. Press **LOGIN**, then enter the **Write Customer** or **Service Password**.
5. Press the **LOGIN** button.
6. Open the Configuration Menu.
7. **PAGE FORWARD** twice.
8. Select **PRINTER SPOOLER**.
9. Select **SERIAL PRINTERS**.

10. Select the correct **COM PORT** for the printer.

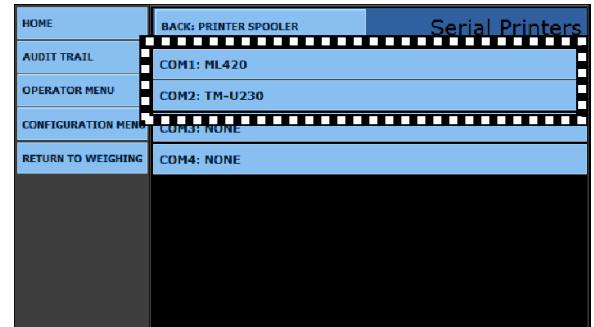
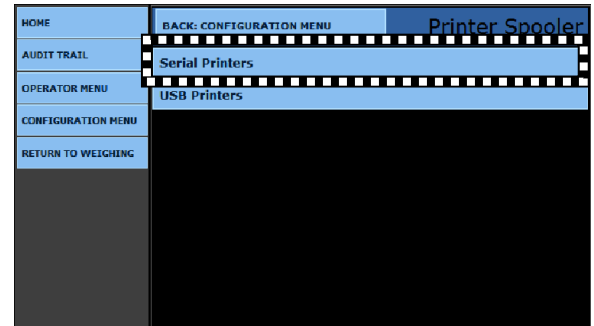
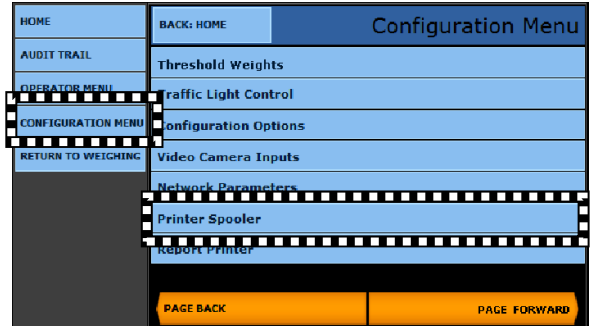

8.1.13. Serial Printer Programming, Continued

11. Open the **PRINTER** option, then select the **correct printer**.

CONNECTION TYPE	PRINTER
USB Only	<ul style="list-style-type: none"> Xerox Phaser 3040 ML420 HP P2055D
Serial	<ul style="list-style-type: none"> iDP3550 TM-U295 SP700 SP-2200 ML420 TM-U590 SP298 SP-2000 TM-U230 EU-T432

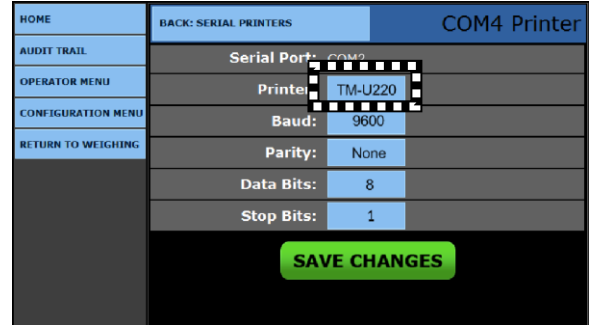

12. Program the parameters for the COM Port to the default printer as noted below.

BAUD RATE	9600
PARITY	None
DATA BIT(S)	8
STOP BIT(S)	1

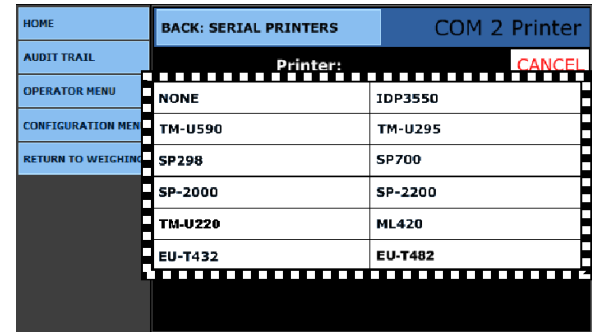

13. If this is the first time the printer is installed on the Instrument, load the **PRINTER DEFAULT FORMATS** by pressing the **YES** button.

- Press the **SAVE CHANGES** button to complete the **Printer Configuration**.

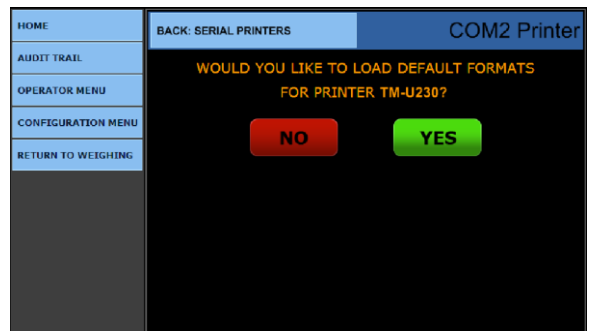

8.1.14.USB Printer Programming

USB Printers are considered “*plug-and-play*” which means with the FB2550 Instrument is loaded with the standard drivers. There is no need to adjust the communication parameters or dip-switches.

Follow these steps to install a **USB Printer**.

1. Plug the printer into the Instrument’s **USB Port**.
2. Turn on the switch.

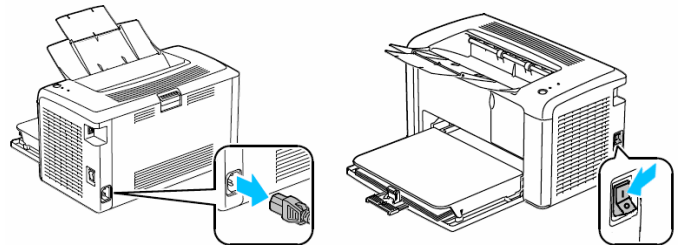

NOTE: USB Printers are typically used for reporting.

3. While in the **CONFIGURATION MENU**, press **PAGE FORWARD** twice.
4. Select **PRINTER SPOOLER**.

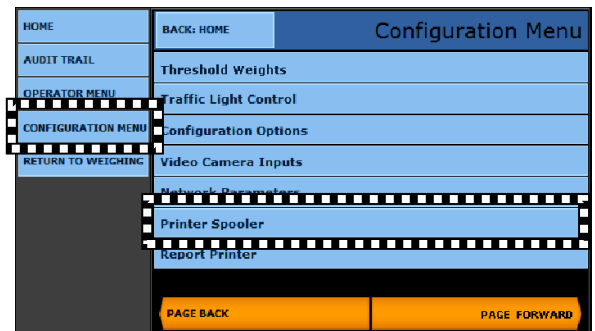

5. Select **USB PRINTERS**.



8.1.14. USB Printer Programming, Continued

6. Select the correct **Printer** from the list.

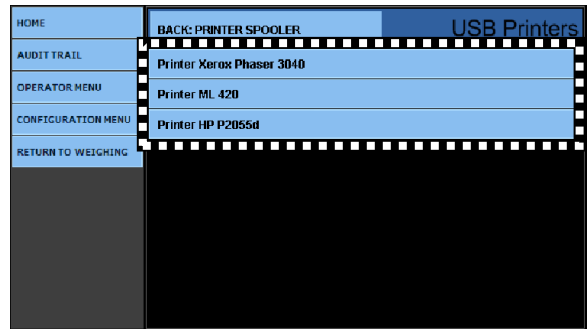

7. If this is the first time installation to this Instrument, load the **PRINTER DEFAULT FORMATS** by pressing the **CONTINUE** button.

- A notice window will appear, stating that the process was positive.

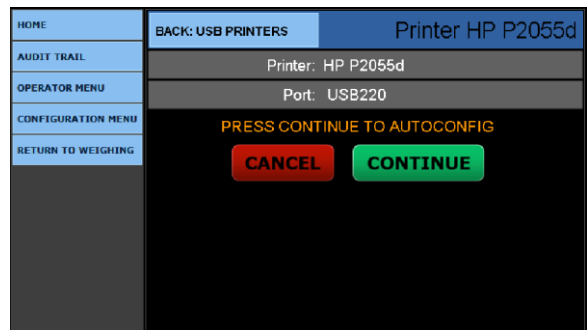

- Press the **SAVE CHANGES** button.

8.2. Format Tickets

Follow these steps to format the tickets for the printers.

NOTE: For additional information, see **Appendix III: Ticket Data Fields.**

1. While in the **CONFIGURATION MENU**, press **PAGE FORWARD**.
2. Select **FORMAT TICKETS**.

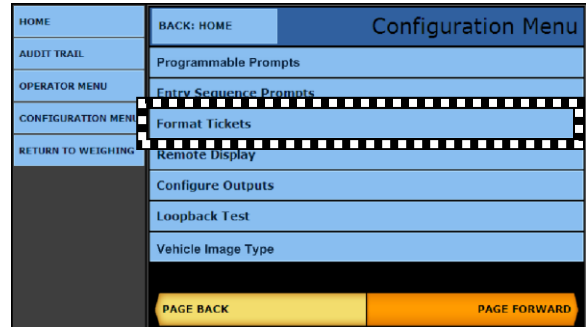

3. Press the **PRINTER** button.

vvvvvvvvvvvvvv

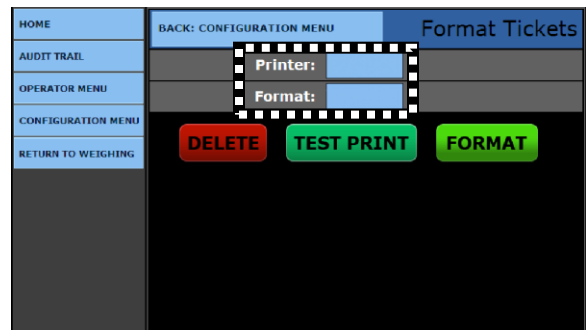

4. Select the correct **printer**.

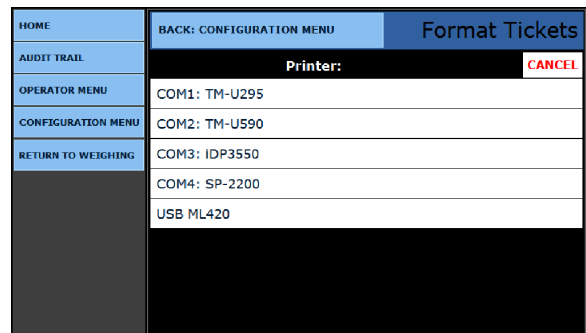

5. Press the **FORMAT** button.
6. Select the **ticket format** to edit or configure.

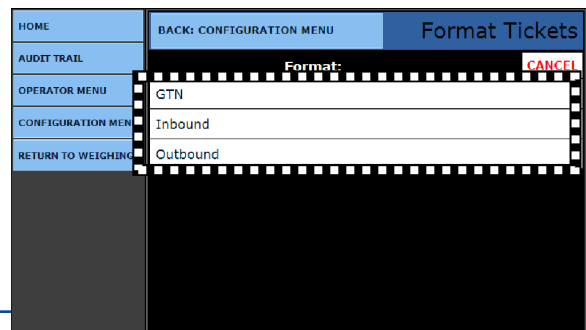

8.2. Format Tickets, Continued

7. Press the **FORMAT** button to access the format item menu.
8. The **FORMAT TICKETS** menu has **nineteen (19) windows** of configurable data windows for each printers ticket format.

TICKET LENGTH and **TICKET WIDTH** configures its size.

EASY FORMAT WT FLDS combines the **Weight**, **Unit** of measure, and **Legend** data fields, so they automatically group together as one field on the ticket.

- Using this option saves the time of manually moving these three data fields individually, and then configuring their placement on the ticket.

✓ **Default = YES**

INVERTED feature prints the ticket from the bottom first, up to the top.

9. Press the **PAGE FORWARD** button to advance to the next page of ticket options.
10. Press the **SAVE CHANGES** button, or they will be lost.
11. Press the **COPY** button to save this ticket format, then posts it to another printer's selected ticket format.

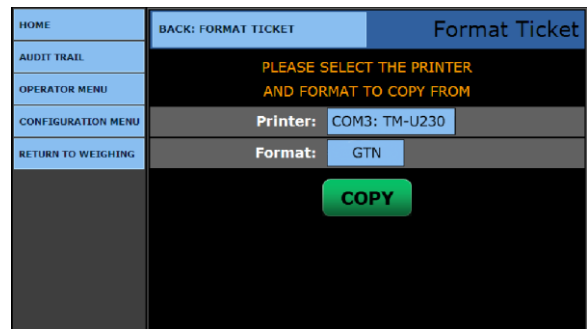
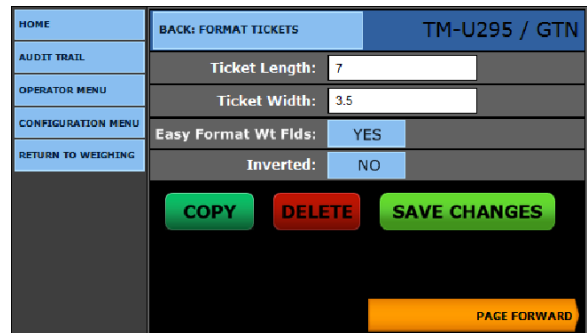
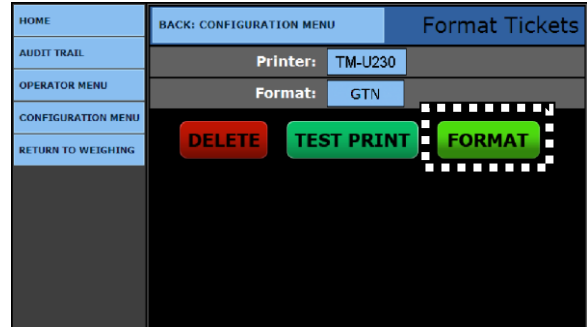

NOTE: *Formatting all the parameter windows will determine how the ticket prints.*

8.2. Format Tickets, Continued

The **DELETE** button function eliminates the ticket format.

- A prompt appears to confirm the operation.

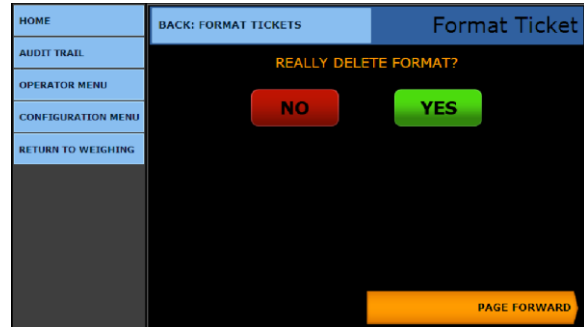

Described below are the three different types of **FIELD**: identifiers within the **FORMAT TICKET** windows.

DATA FIELD –Data which is emphasized within **greater than** and **less than symbols** is derived from the FB2550 and the vehicle which is being weighed.

Example: **<Gross WT>**

- This is the actual weight value which was weighed on the scale.

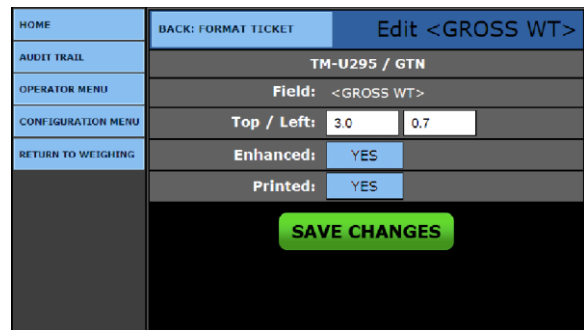

LABEL FIELD – Data which is **text only**, and describes the data field that it is beside.

Example: **GROSS LABEL**

- This label describes the label as a **GROSS** weight value.

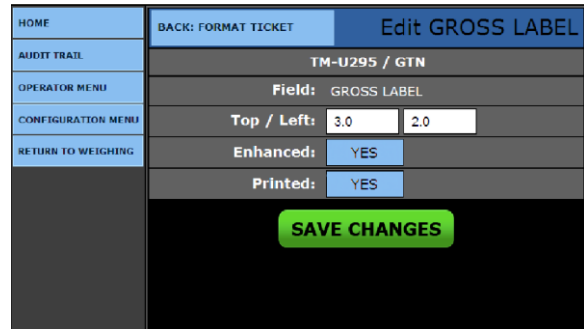

TEXT FIELD – Custom text entered to provide required information on the ticket.

Example:
Driver: _____

- This gives driver a place to sign a ticket.

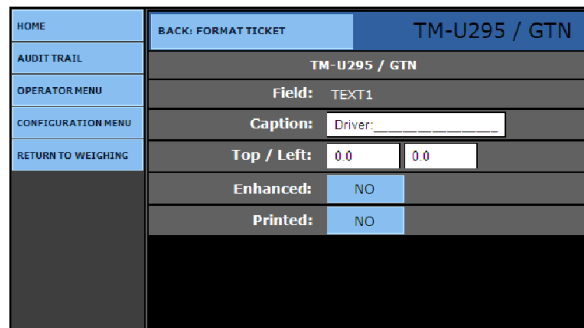

8.2. Format Tickets, Continued

TOP / LEFT: Plots the **x-y coordinates** of where the fields are located.

- **TOP** field moves the data field in an **up and down** position.
 - *This value is incremented in **tenths (0.1) of an inch**.*
- **LEFT** field moves the data field in a left to right direction.
 - *This value is incremented in **tenths (0.1) of an inch**.*

- In the **ENHANCED FIELD**, select **YES** to **enable** emphasized print, or **NO** to **disable** it.
- In the **PRINTED** field, select **YES** to **enable** printing the data item, or **NO** to **disable** it.

HOME	BACK: FORMAT TICKET	Edit <GROSS WT>	
AUDIT TRAIL	TM-U295 / GTN		
OPERATOR MENU	Field: <GROSS WT>		
CONFIGURATION MENU	Top / Left:	<input type="text" value="3.0"/>	<input type="text" value="0.7"/>
RETURN TO WEIGHING	Enhanced:	<input type="text" value="YES"/>	
	Printed:	<input type="text" value="YES"/>	
<input type="button" value="SAVE CHANGES"/>			

- Press the **SAVE CHANGES** button, or they will be lost.
- Selecting **BACK: FORMAT TICKET** returns to the previous menu.

8.3. Web Ticket Layout

8.3.1. Overview

Web Ticket Layout configures the fields on a scale ticket in a **WYSIWYG** format (**What You See Is What You Get**).

- This allows a user to create and modify ticket layouts by drag-and-drop fields from a list onto the ticket.
- The printed ticket will look like what is laid-out on the web page.
- This is only accessible using a computer web browser, and not available on the screen of the instrument.
- The original ticket format capability still remains available using a web browser or directly on the instrument.

8.3.2. Programming a Web Ticket

Follow these steps to **Program a Web Ticket**.

12. Enter the **IP ADDRESS** of the target FB2550 Instrument into a Networked computer's web browser **Address Field**.
 - **Do NOT** select **SHOW AS LOCAL** for the web-based applications.
13. Input the **Remote Service Password**.
14. Press **ENTER**.
15. In the FB2550 Instrument window, select **LOGIN**.
16. Open the **CONFIGURATION MENU**.
17. Click on the **FORMAT TICKETS** option.

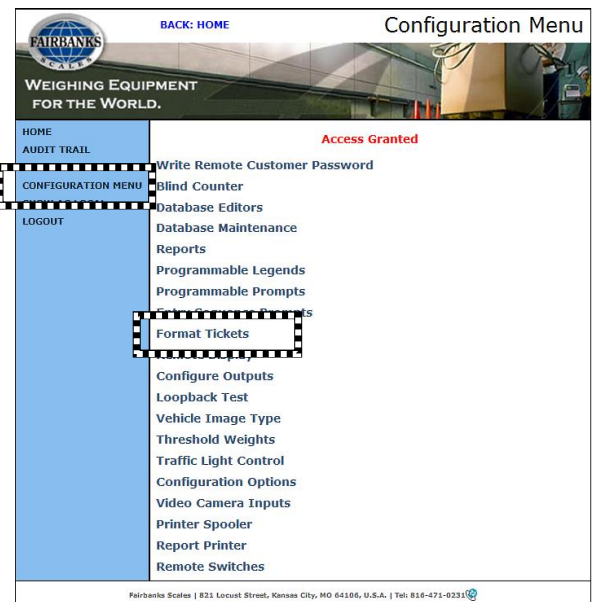
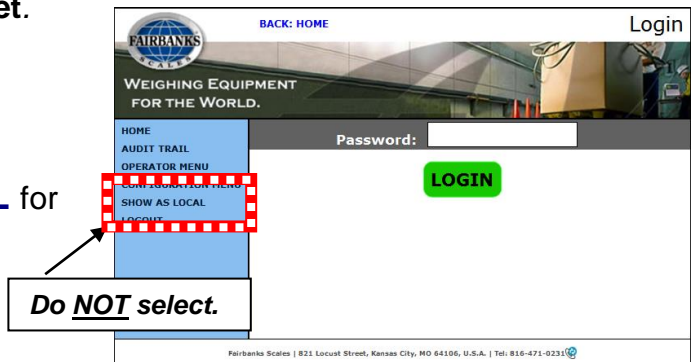

8.3.2. Programming a Web Ticket, Continued

18. Click the **WEB TICKET LAYOUT** button.
- Opening this loads (or create) the parameters for this specified ticket.

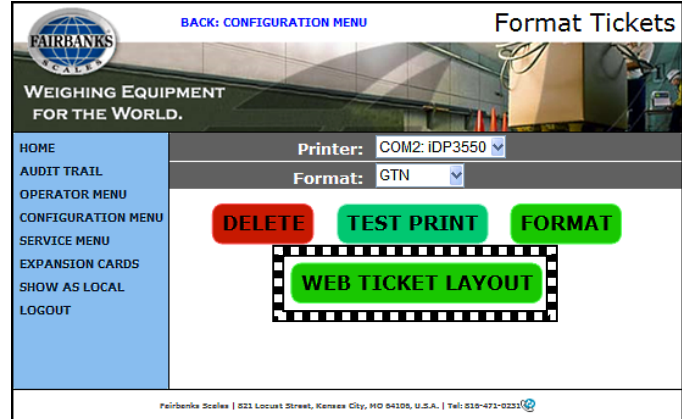

The three sections of the **Web Ticket Programming** are listed below.

- A. **General Layout Options** are settings that apply to the entire ticket, or that control significant behavior of the printed ticket layout.
- B. **Fields** list contains an alphabetical list of available fields that can be printed on a ticket.
 - Each field can be dragged-and-dropped into place.
- C. **Ticket Layout** field is a visual representation of the scale ticket.
 - Each **Fields** option can be dragged-and-dropped into place.

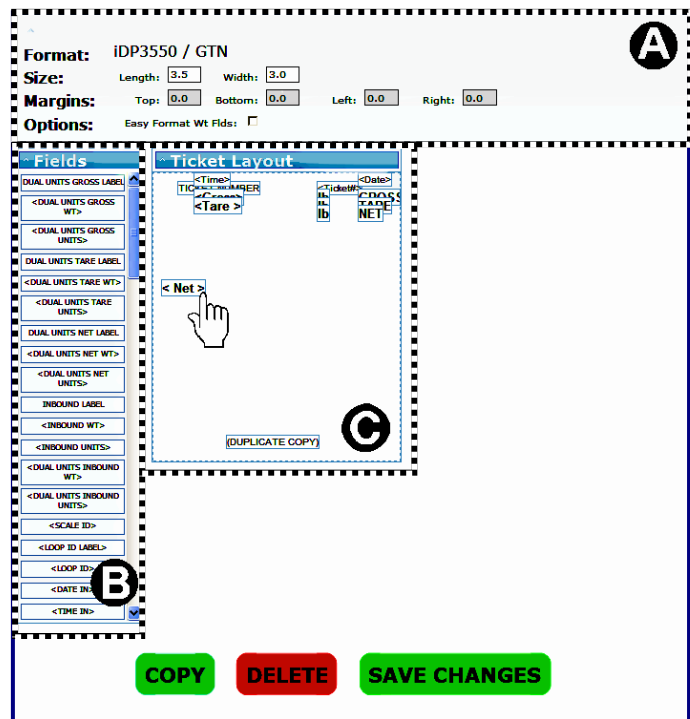

This image displays the ticket format setup of a **Citizen iDP3550 Printer**.
 – The ticket size is **3.5" x 3"**.

- Pressing the **COPY** button saves this ticket to RAM memory to format a similar ticket.
- Highlight a **Field**, then press **DELETE** to remove it.
- Press the **SAVE CHANGES** button.

8.3.2. Programming a Web Ticket, Continued

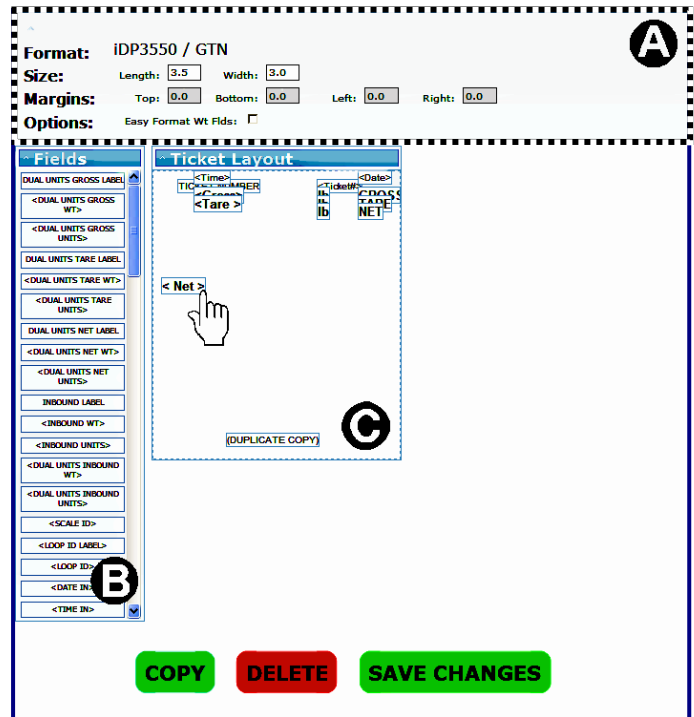

A. GENERAL LAYOUT OPTIONS

GENERAL LAYOUT OPTIONS are settings that apply to the entire ticket, or that control significant behavior of the ticket printing or layout.

- Not all options are available for all printers, and ones which don't apply are disabled.
- **Size** sets the dimensions of the data field boxes (*in inches*).
 - If the field box is set smaller than the text size, it enlarges to fit.
 - For **serial printers**, *the print size cannot be changed*.
 - Once changed, click out of the field and the layout will update.
- **Margins** places the location of the data field box on the ticket.
 - Data field boxes are placed on the ticket according to the **TOP, BOTTOM, LEFT** and **RIGHT** page coordinates in inches.
 - A light dashed line represents the margins.
 - These values are rounded to the nearest tenth of an inch ($1/10$ ").
- **Easy Format Weight Fields** is *not recommended* when using the Web Ticket Layout.
- **Inverted** prints the ticket inverted.
 - This option may not be available on all printers.

NOTE: For serial printers, the margin values are disabled and set to **ZERO**.

8.3.2. Programming a Web Ticket, Continued

B. FIELDS LIST

The field list contains an alphabetical list of available fields to be printed on a ticket.

- Each field can be dragged onto the **Ticket Layout** area and dropped in place.
- Only fields in the **Ticket Layout** are printed.
- Once on the ticket, a **Field** can be removed from the ticket by dragging it back to the **Field List** and dropping it.
 - The **Field** will be placed back in its original order.
- While in the **Ticket Layout** area, the **Fields** can be formatted by double-clicking on it.

C. TICKET LAYOUT

The **TICKET LAYOUT** area is a visual representation of the scale ticket.

- Printable fields can be dragged from the field list and dropped on to the ticket layout.
- Fields already on the ticket can also be dragged to different positions on the ticket.
- The fields are displayed with any formatting, and the text is the field caption.
 - If there is no caption, the **Field Name** is used.

Field Positions are saved (on submit), and are printed in that position.

Field Sizes for *serial printers* adjust automatically to fit the text size, and cannot be changed

Only fields in the **TICKET LAYOUT** area are printed.

- To remove a field, drag it back to the **Field List**.
- The **Ticket Layout** area is close to the actual physical size to the ticket.
 - It may not be exactly.
 - The size and position of the fields are proportional to the size of the ticket.
 - The dashed line represents the printer margins set in the **General Layout Options**.
- All fields in the **Ticket Layout** adjust automatically to fit the text.
 - The field can be made larger if desired, but not smaller than the given text.

This image displays the axle weighing format setup of a Epson TM-U590 Report Printer.

*Drag-and-drop any option from the **Fields** list (B) onto the **Ticket Layout** frame (C).*

This is a WYSIWYG ("What You See Is What You Get") programming application.

- Placement of the fields will snap to the nearest tenth of an inch.
- When dragging a field less than this distance, the field returns to its original position.

D. SCALE SUMMING FORMAT

*This example displays the **SCALE SUMMING** format.*

- Tickets can be formatted to print all platform weights, as well as the calculated total.
- Use the **TEXT FIELDS** in the print format settings print the individual platform weights.
- Use **TEXT FIELDS 1, 2** and **3** for the **STEERING, DRIVE** and **TRAILER** platforms.
- The total of the weighments will be the **GROSS WEIGHT** field.

Format: TM-U590 / Outbound

Size: Length: Width:

Margins: Top: Bottom: Left: Right:

Options: Easy Format Wt Flds: Inverted:

Fields

- GROSS LABEL
- DUAL UNITS GROSS LABEL
- <DUAL UNITS GROSS WT>
- <DUAL UNITS GROSS UNITS>
- DUAL UNITS TARE LABEL
- <DUAL UNITS TARE WT>
- <DUAL UNITS TARE UNITS>
- DUAL UNITS NET LABEL
- <DUAL UNITS NET WT>
- <DUAL UNITS NET UNITS>
- INBOUND LABEL
- <INBOUND WT>
- <INBOUND UNITS>
- <DUAL UNITS INBOUND WT>
- <DUAL UNITS INBOUND UNITS>
- <SCALE ID>

Ticket Layout

(DUPLICATE COPY)

TICKET NUMBER <Ticket#>

<Date> <Time>

STEERING lb

DRIVE lb

TRAILER lb

TOTAL WEIGHT <Gross> lb

 TARE <Tare > lb

 NET <Net > lb

TRUCK ID <Loop ID>

*This shows the basic elements of the **SCALE SUMMING** format.*

8.3.2. Programming a Web Ticket, Continued

E. FORMAT OPTION

The **FORMAT** window is an advanced view of the **WEB TICKET LAYOUT**.

1. After formatting the ticket, press the **TEST PRINT** button. Study the ticket to confirm that it is formatted correctly.
2. Press the **FORMAT** button to move, remove or add an element on the ticket.

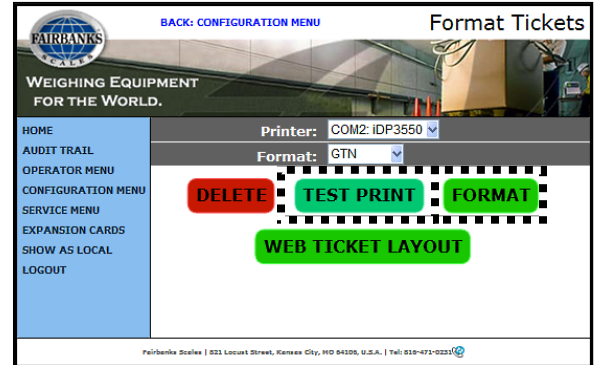

- Press the **BACK: FORMAT TICKETS** button to return to the previous menu.
 - Doing this does not save any changes.
- Press the **COPY** button to save these ticket formatting parameters into RAM memory for another similar ticket.
- Press **DELETE** to remove the ticket completely.
- Press the **SAVE CHANGES** button, or they will be lost.



- The top frame of this window gives the same formatting options of the **Web Ticket Layout**.
- The bottom frame lists all of the formatting options, the input field coordinates (*in inches*), and any associated link.
- Any field(s) already placed on the ticket structure is highlighted in dark gray.

3. Double-click on any of the formatting options to add this field onto the Ticket.
 - Once selected, the top frame displays all of the choices from this formatting option, according to its parameter needs.

8.4. Serial Card

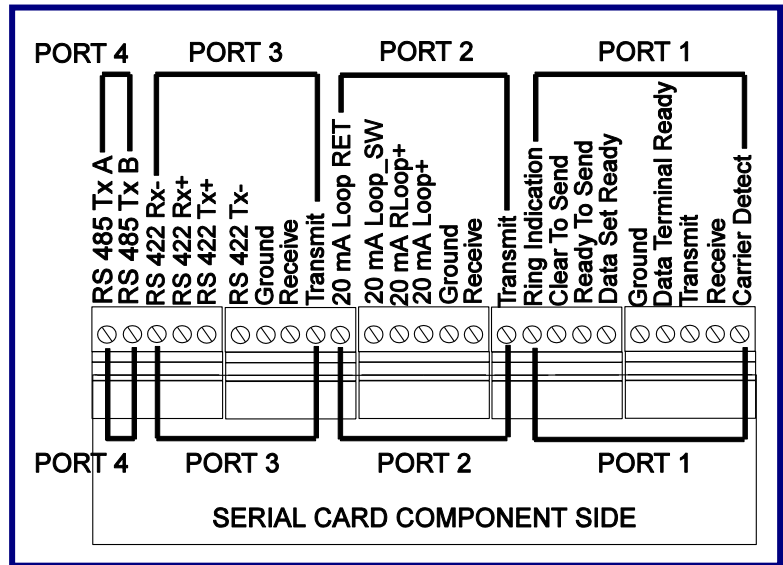

The **SERIAL CARD (30921)** provides **four (4) outputs** with a maximum of **two (2) cards** per Instrument. See the Port Assignments listed below.

- A bus cable is provided, connecting the Multi-function Board to the Expansion Card.

PORT 1	RS-232 (Full Duplex 9 Pin Port)
PORT 2	RS-232 OR 20mA *
PORT 3	RS-232 OR RS-422 *
PORT 4	RS-485

* Only one (1) may be selected at a time, and not both.

8.5. Serial 20mA Interfaces

Described below are the two **Serial 20mA Interfaces** typically used for a **Remote Display**.

- A FB2550 Instrument can use **only one** of these two interfaces.

SERIAL 20mA MULTI-FUNCTION BOARD (29970)

Communicates with the **Remote Display**

- One-way output only.
- An **ACTIVE 18VDC POWER SUPPLY SETUP** is recommended.
- The Remote Display is configured for the **20mA Interface**.

SERIAL 20mA EXPANSION BOARD

Provides additional COM Ports for the Instrument.

- Supplies **Serial 20mA, RS-232 or RS-485 Output**.
- An **ACTIVE 18VDC POWER SUPPLY SETUP** is recommended.

8.5.1. Multi-Function Board

Below are images showing the Multi-function Board connections.

- Use a **20mA CURRENT LOOP CONNECTION** for the **Remote Display**.

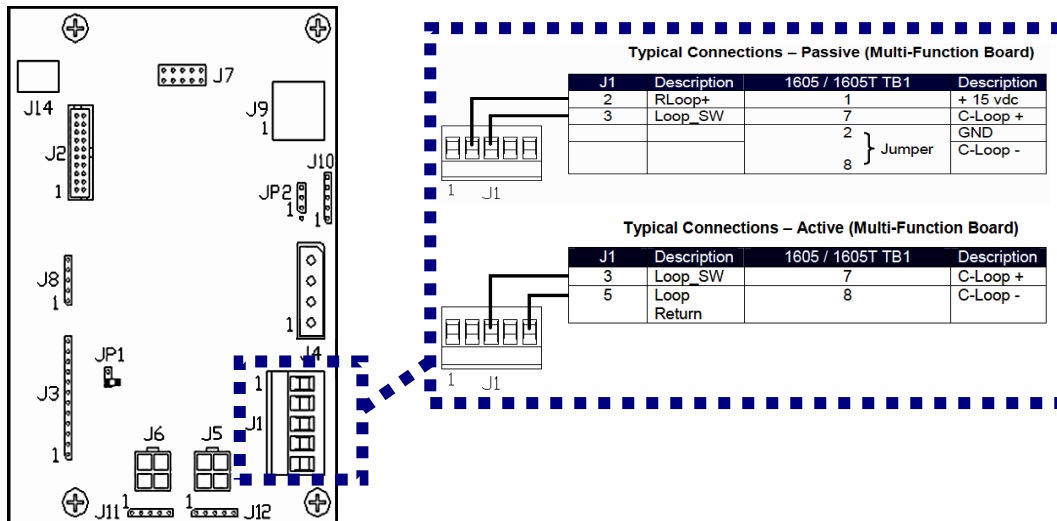

8.5.1. Multi-Function Board, Continued

These following steps to configure the FB2550 for use with the serial 20mA to a remote display.

4. While in the **CONFIGURATION MENU**, press **PAGE FORWARD**.
5. Select **REMOTE DISPLAY**.

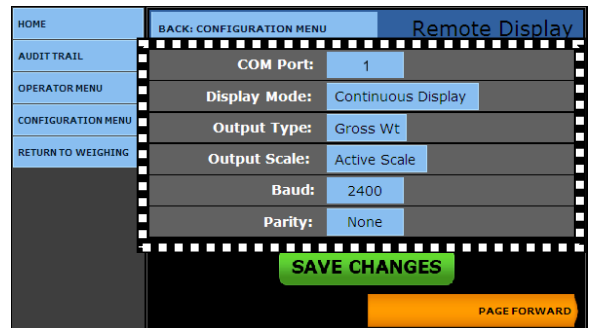
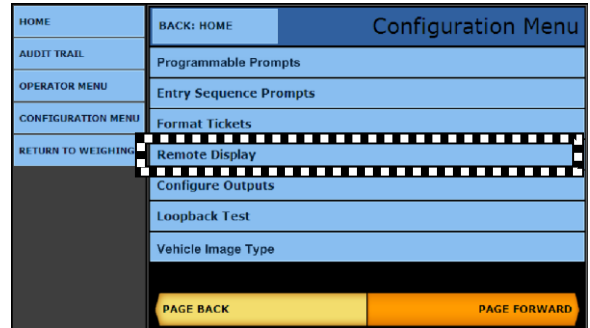

Select from the following options as appropriate for the application. Format the communication settings according to the default parameters on the right.

APPLICATION SETTINGS	
COM Port	OFF, COM1 – COM4, COM25 – 28*, COM25 – 32*
Display Mode	Continuous Display, Display on Print
Output Type	Gross Wt, Net Wt, Ticket Number
Output Scales	Active Scales, Scale 1 thru 8, All Scales

PARAMETERS	
Baud	2400
Parity	None
Data Bits	8
Stop Bits	1

* Dependent upon number of **Serial Expansion Cards**.

8.5.1. Multi-Function Board, Continued

6. Press **PAGE FORWARD** once.
7. Check the **Enabled 1605T Remote Display Traffic Light Control** if this accessory is installed.
8. Turn **ON** the 20mA Output option when using the Multi-Function Board.
 - This allows **20mA Output**, located at **J1** on the Multi-Function Board.

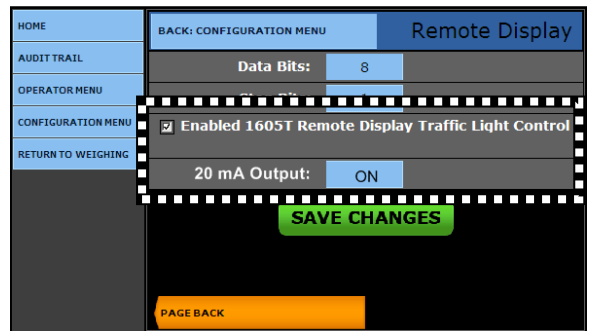

9. Configure the **20mA Output** to these *recommended* settings.

BAUD RATE	2400
PARITY	odd
DATA BIT(S)	7
STOP BIT(S)	1

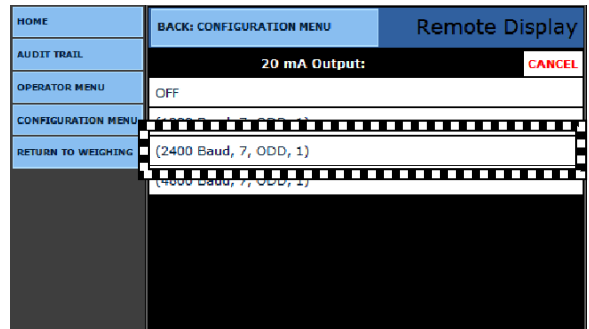

8.5.2. Serial Expansion Board

10. While in the **CONFIGURATION MENU**, press **PAGE FORWARD** once.
11. Select Remote Display.

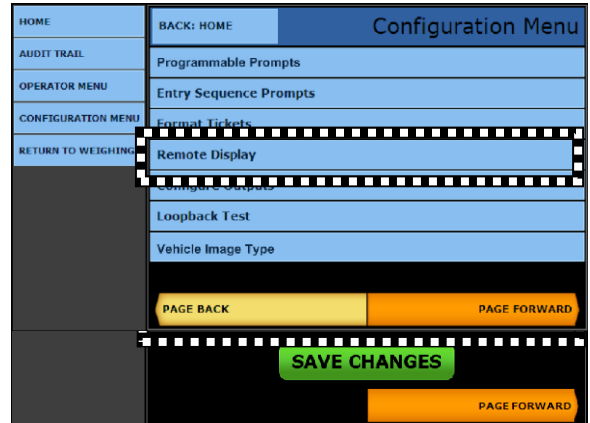

Select from the following options as appropriate for the application. Format the communication settings according to the default parameters on the right.

APPLICATION SETTINGS	
COM Port	OFF, COM1 – COM4, COM25 – 32 *
Display Mode	Continuous Display, Display on Print
Output Type	Gross Wt, Net Wt, Ticket Number
Output Scales	Active Scales, Scale 1 thru 8, All Scales

PARAMETERS	
Baud	2400
Parity	None
Data Bits	8
Stop Bits	1

* The number of available COM Ports depends upon the Expansion Card used.

12. Check the **Enabled 1605T Remote Display Traffic Light Control** if this accessory is installed.
13. When using the **Serial Expansion Board**, leave the **20mA Output** turned **OFF**.
 - This **turns on** the 20mA output, located at **J1** on the **Multi-Function Board**.
 - This is *not required* for this **Configuration Setup**.

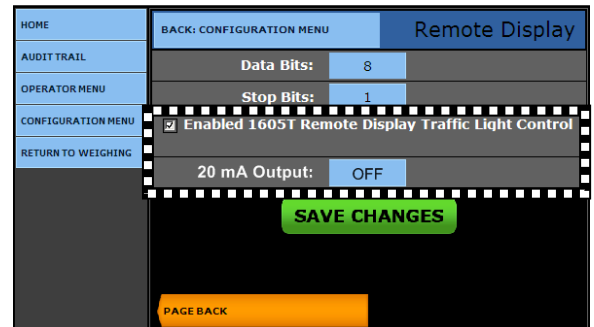

8.6. Configure Outputs

This menu configures data string protocols, configuration parameters, and output modes such as **Continuous**, **Demand**, **Auto**, **Network (Continuous)**, and **Network (Auto)**.

8.6.1. Configuring an Output Data String

In order to interface an FB2550 Instrument to software or a pre-existing peripheral device, such as a remote display, knowing their specific Data Output String is **mandatory**.

- This allows the software or peripheral device to communicate with the FB2550 for weight data.
- When adding to other manufacturer's devices, refer to their Service Manuals for Data Output String information.
- Interfacing with other manufacturer's software, refer to either a web site, Service Manual, or contact the manufacturer directly for the Data Output String information.

8.6.2. Two Methods of Formatting

Noted below are the two methods to format an Data Output String.

A. Preconfigured Output

- This method uses one of the seven (7) **Preconfigured Outputs** in the **LOAD** menu.

B. Customizing the Data Output Strings

- This method uses a **Preconfigured Output** from the **LOAD** menu as a base format. Then the message in the **Data Output String** is customized in the **BUILD** menu to match the customer's specific configuration requirements.

8.6.3. Method 1 – Preconfigured Output

Follow these steps to configure an **Data Output String** on the FB2550, completed in the **Configuration Menu**.

1. While in the **WEIGH SCREEN**, press the **MENU** button.
2. Select **LOGIN**.
3. Enter the **Write Customer Password** or **Service Password**.
4. Press the **LOGIN** button.
5. Select the **CONFIGURATION MENU**, and then press **PAGE FORWARD** once.
6. Select **CONFIGURE OUTPUTS**.
7. Select **CONFIGURE COM X**, where **X** is the desired COM port location
 - **CONFIGURE COM1** is used as an example for the following images.

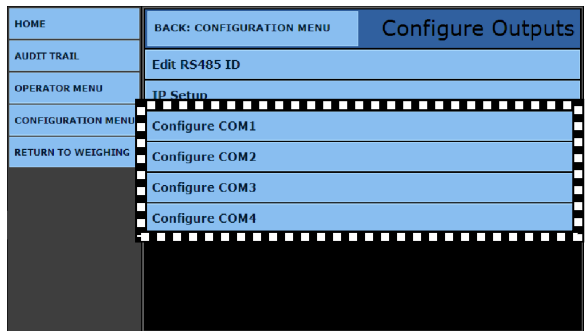
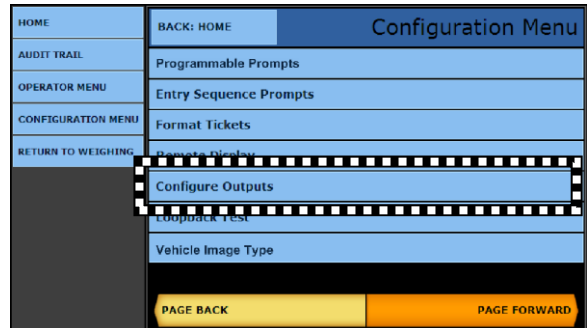

8. Press the **LOAD** button.

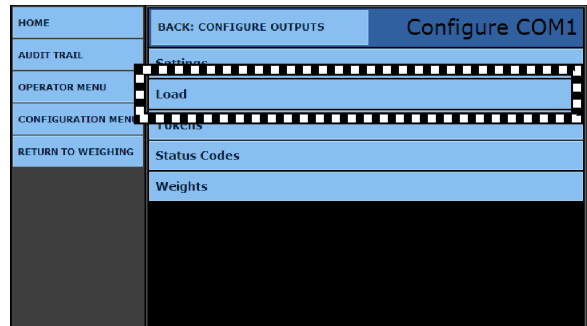

9. Select the correct **Load format**.
 - When configuring an data output string, the FB2550 has **seven (7)** commonly used **preconfigured outputs**.
 - **CONFIGURE COM1** was selected in **Step 8** for the following data string build example.
 - See **Appendix II: Data Output** for further information.

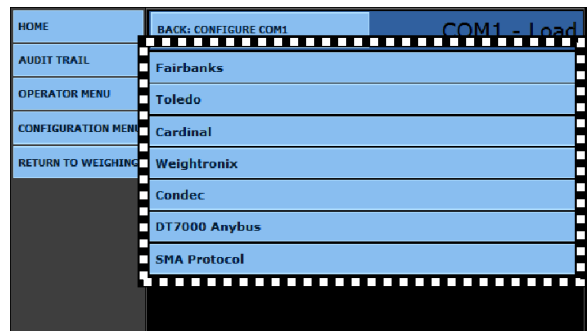

8.6.3. Method 1 – Preconfigured Output, Continued

10. Press the **YES** button to load the default configuration for the data protocol selected.

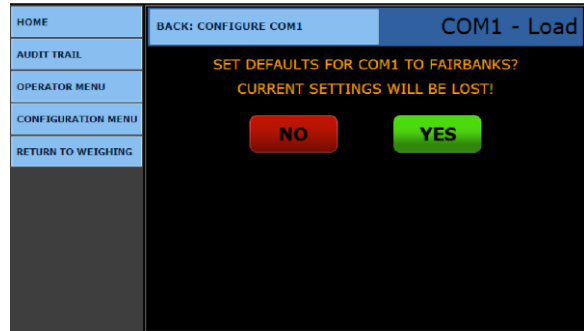

For a few seconds, a similar message to this verifies a successful load.

11. Verify the **CONFIGURATION BAUD, PARITY, STOP BITS** to be at the correct values.



12. Enter the **MODE** menu to configure the data transmission method.

OFF – COM port is disabled.

CONTINUOUS – The COM port transmits the data string continuously per every display update.

DEMAND – The data string is transmitted upon receiving the programmed poll character from a peripheral device.

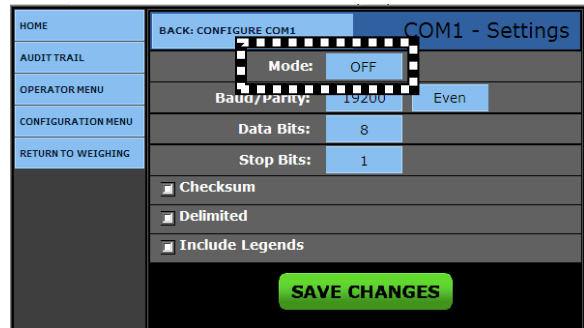

AUTO – The data string is transmitted upon the printing of a transaction.

NETWORK (CONTINUOUS) - The data string is transmitted continuously per every display update through the network connection.

NETWORK (AUTO) - The data string is transmitted upon pressing print and the printing of a transaction will transmit the transaction through the network connection.

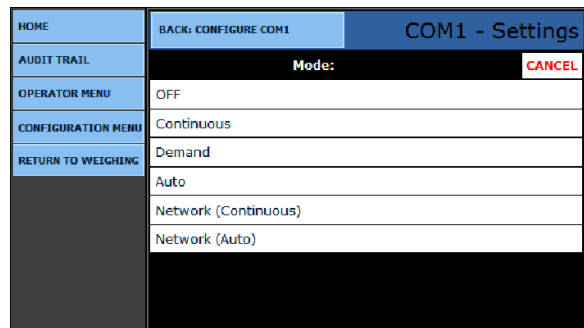

8.6.3. Method 1 – Preconfigured Output, Continued

13. Open the **BAUD/PARITY** menu and select the correct **Baud Rate**.

HOME	BACK: CONFIGURE COM1	COM1 - Settings
AUDIT TRAIL	Baud/Parity: CANCEL	
OPERATOR MENU	115200	
CONFIGURATION MENU	57600	
RETURN TO WEIGHING	38400	
	19200	
	9600	
	4800	
	2400	
	1200	

14. Select the required **PARITY** rate from the menu list.

HOME	BACK: CONFIGURE COM1	COM1 - Settings
AUDIT TRAIL	Baud/Parity: CANCEL	
OPERATOR MENU	Even	
CONFIGURATION MENU	Mark	
RETURN TO WEIGHING	None	
	Odd	
	Space	

15. Open the **DATA BIT** menu and select the correct setting.

HOME	BACK: CONFIGURE COM1	COM1 - Settings
AUDIT TRAIL	Data Bits: CANCEL	
OPERATOR MENU	5	
CONFIGURATION MENU	6	
RETURN TO WEIGHING	7	
	8	

16. Open the **STOP BIT** option and select the correct setting from the menu list.

HOME	BACK: CONFIGURE COM1	COM1 - Settings
AUDIT TRAIL	Stop Bits: CANCEL	
OPERATOR MENU	0	
CONFIGURATION MENU	1	
RETURN TO WEIGHING	2	

CHECKSUM option verifies the data sent and received is free from corruption when Networking.

DELIMITED option separates elements within the data string with commas, line feeds, etc.

INCLUDE LEGENDS option turns on and off the **Unit Legends** sent within the data string, such as **LB, KG GROSS, TARE**, etc.

- Not used for the display functions.

17. Press the **SAVE CHANGES** button, or they will be lost.

HOME	BACK: CONFIGURE COM1	COM1 - Settings
AUDIT TRAIL	Mode: OFF	
OPERATOR MENU	Baud/Parity: 19200	Even
CONFIGURATION MENU	Data Bits: 8	
RETURN TO WEIGHING	Stop Bits: 1	
	<input checked="" type="checkbox"/> Checksum <input checked="" type="checkbox"/> Delimited <input checked="" type="checkbox"/> Include Legends	
	SAVE CHANGES	

8.6.4. Method 2 – Customizing Data Output Strings

The FB2550 Instrument can be customized to support different manufacturer’s software interfaces to peripheral devices.

- When the required data string protocol is not similar to one of the preconfigured outputs, the data output string must be **programmed manually** using the **BUILD, TOKENS, AND WEIGHTS** menus.

Follow these steps to customize the **Data Output String**.

1. While in the **CONFIGURATION MENU**., press **PAGE FORWARD** once.
2. Select **CONFIGURE OUTPUTS**.

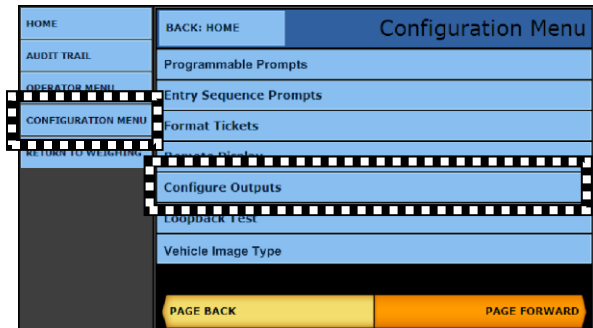

3. Select **COM PORT X** to configure the output data string.

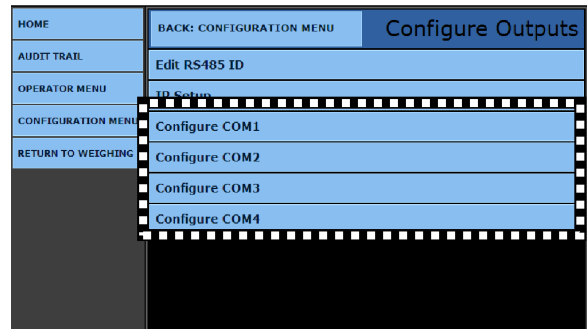

4. Press the **LOAD** option.

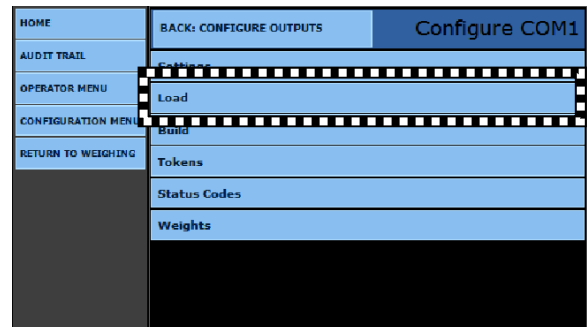

8.6.4. Method 2 – Customizing Data Output Strings, Continued

When configuring an output data string, the FB2550 Instrument has **seven (7)** commonly used preconfigured outputs.

5. Select the correct **Load format**.
 - **Configure COM1** was selected in **Step 8** for the following data string **BUILD** example.
 - The **Data String Load** selected is the one used as the foundation for customizing the **BUILD**.



6. Press the **YES** button to load the default configuration for the data protocol selected.

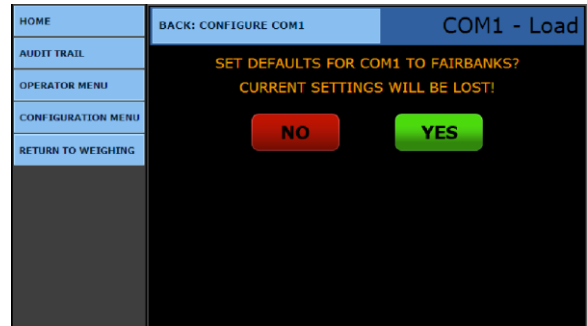

For a few seconds, a similar message to this verifies a successful load.

7. Select the **BUILD** option to begin customizing the data string.

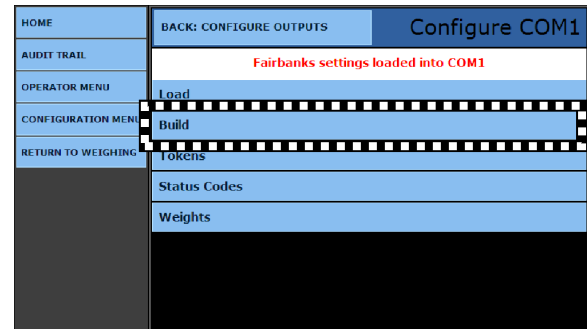

The **BUILD** window displays.

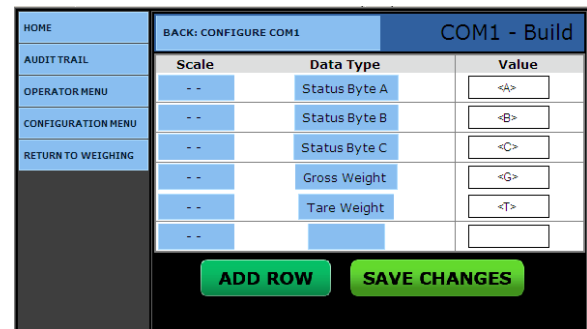

8.6.4. Method 2 – Customizing Data Output Strings, Continued

8. Select the **SCALE**, if entering this field applies.

- This option applies to sites with more than one scale.
- Selecting the **Scale** will limit the available options for configuring its data string.
- If this field is left blank and there is more than one scale on the site, all formatting will default to the scale that is currently being formatted.

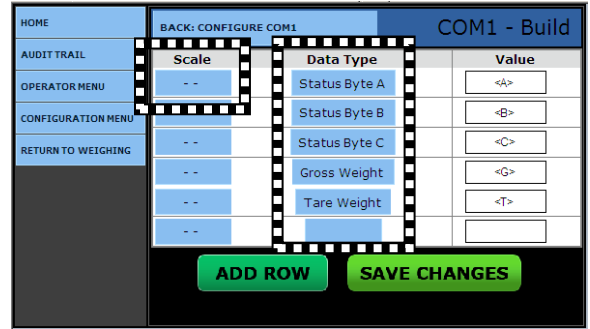

9. Select a **DATA TYPE** input field to edit it.

Listed below are the available options for building the data string.

- **TEXT** – Allows text entry values in the location.
- **UNITS TOKENS** – Designates the unit of the data such as **lbs** or **kgs**.
- **MODE TOKENS** – Designates if the weight is **Gross, Tare, or Net**.
- **SCALE STATUS** – Designates the operating status of the scale such as **motion, overcapacity, and behind zero**.
- **LOAD CELL STATUS** – Designates if a load cell has a potential problem.
- **STATUS BYTE A, B or C** – Similar to Scale Status item but also includes **graduation size, decimal point, and units**.
- **GROSS WEIGHT, TARE WEIGHT, NET WEIGHT** – Weights retrieved from the scale selected for the data item configured.
- **DISPLAYED WEIGHT** – Value which is currently shown on the display.
- **<<REMOVE>>** – Removes the data item selected from the data string configuration.

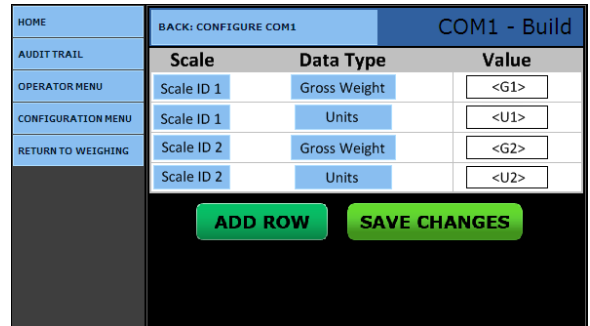
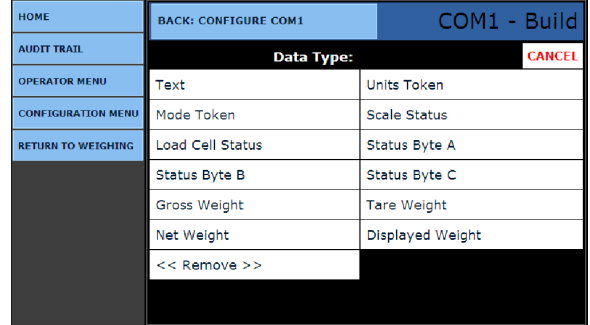
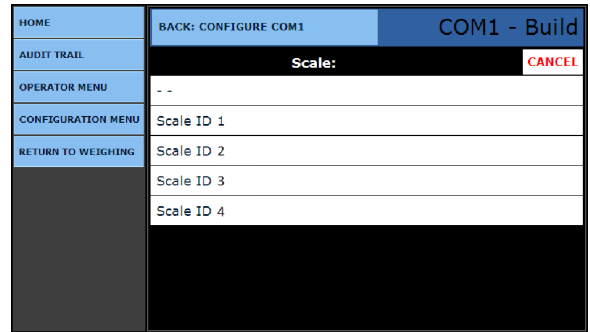

The image above is a common example of how the data string could be reformatted to match the customer's requirements.

10. Press the **SAVE CHANGES** button to save and exit to the **BACK: CONFIGURE COM1** menu.

8.6.4. Method 2 – Customizing Data Output Strings, Continued

ADDING A NEW DATA TYPE

1. In the **COMX – Build** window, press the **ADD ROW** button for a new **Data Type** item, placed at the end of the string.
2. Select the correct **SCALE**, if this applies.
3. Open the **DATA TYPE** entry field, and select the correct one.
4. Press the **SAVE CHANGES** button to save and exit to the **BACK: CONFIGURE COM1** menu.
5. In the **Configure Options** menu, select the **TOKENS** menu.

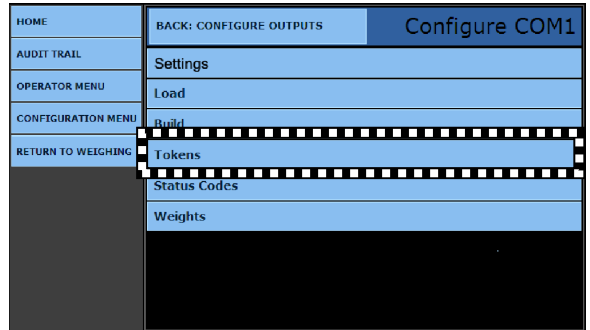
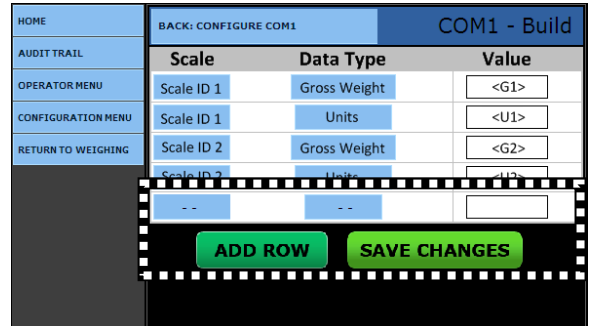

6. In the **COMX – Tokens** window, open the **POLL** option to select a polling character for the **Demand Mode**.

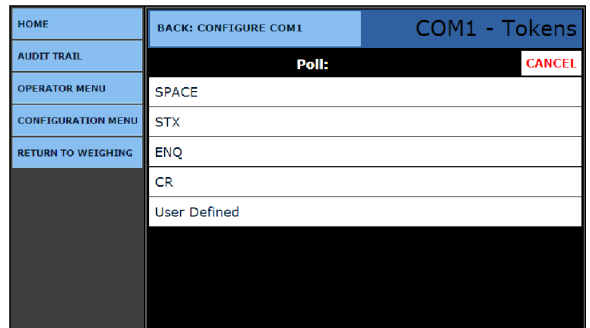
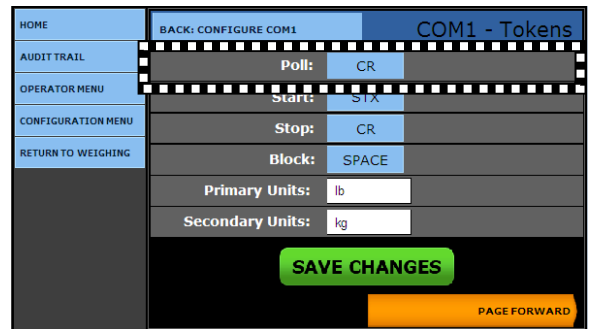

8.6.4. Method 2 – Customizing Data Output Strings, Continued

7. In the **COMX – Tokens** window, open the **START** to select the available start character *for all modes*.

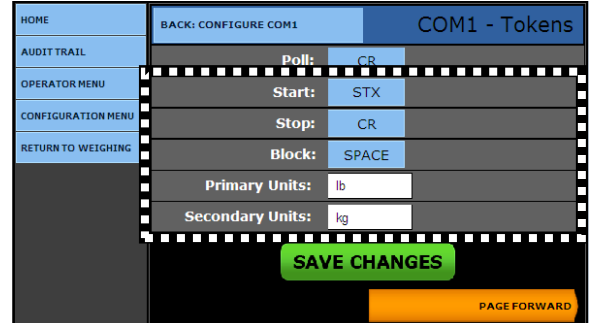

8. Open the **STOP** option to select the available **Stop** character *for all modes*.

9. Open the **BLOCK** option to select the available **Data Block Separator** character *for all modes*.

10. Enter the **PRIMARY UNITS** legend.

– Example: **lb**

11. Enter the **SECONDARY UNITS** legend.

– Example: **kg**

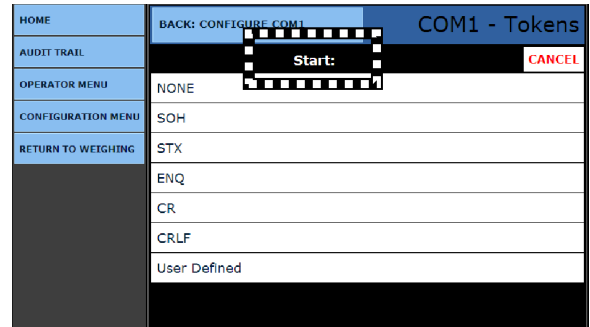
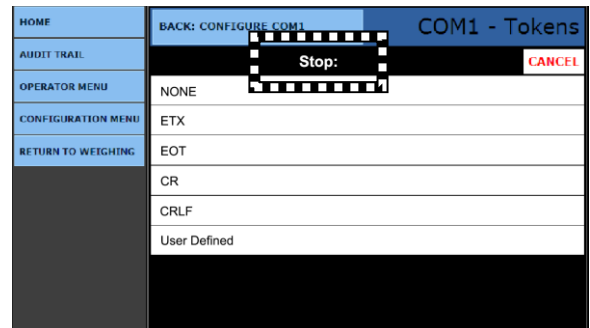



NOTE: Format all Threshold Weight settings to the same **PRIMARY UNITS** used, preventing any errors in programming.

8.6.4. Method 2 – Customizing Data Output Strings, Continued

12. Press **PAGE FORWARD** once.

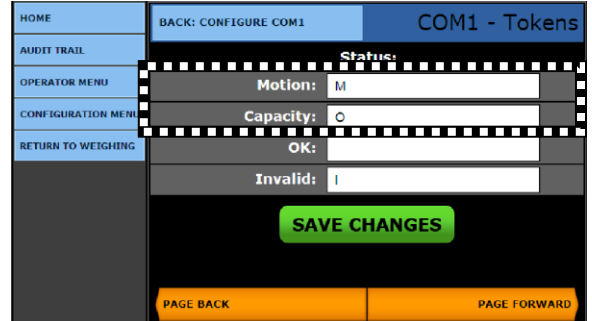
- This page configures the **Status: token** for the output data string.
- Each item configured will indicate the character programmed in the output data string.
- If **Motion** is present on the scale, a **“M”** will be transmitted in the data string.
- The **Capacity** value will indicate if the scale is overloaded.



13. Press **PAGE FORWARD**.

- This page configures the **Mode: token** for the output data string.
- Each item configured will indicate the character(s) programmed in the output data string.
- The **Remote Commands** configuration establishes if a **CARRIAGE RETURN** is required when sending a remote command, such as a **Zero Command**.
- If the **CARRIAGE RETURN** check box is selected, the remote **Zero Command** is **Z<CR>**.
- Otherwise it would be a **“Z”** only.

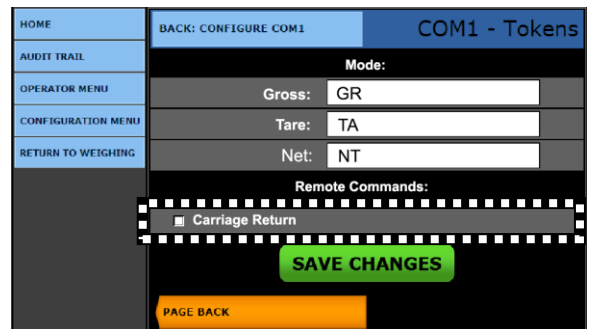

14. Select **RETURN TO WEIGHING TO TEST** and verify the output is producing the desired results.

- Press the **SAVE CHANGES** button, or they will be lost.

8.6.5. Configuring a COM Port for Scale Summing

Follow these step to program **Scale Summing**.

1. While in the **CONFIGURATION MENU**, press **PAGE FORWARD** once.
2. Select **CONFIGURE OUTPUTS**.

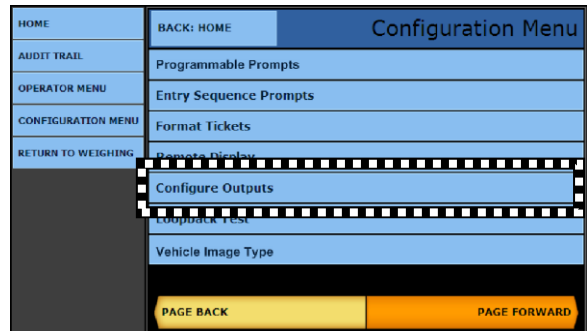

3. Select the correct **COM Port** to configure the output data string.

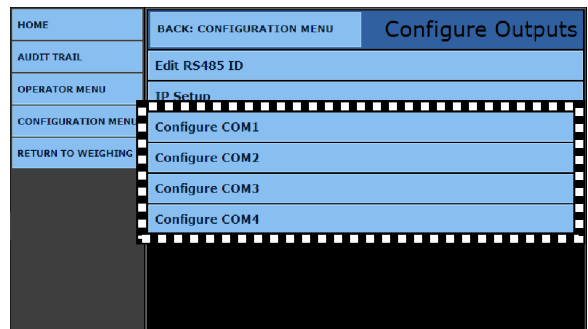

4. Press the **BUILD** option.

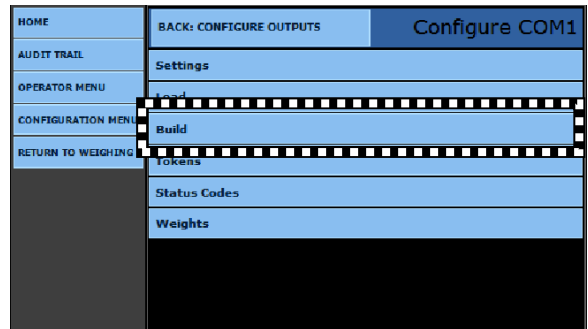

5. To configure the **COM Port Output** for **SCALE SUMMING**, set the window similar to the sample screen to the right.



8.7. IP Output Configuration

The IP Output is available using the Ethernet connection of the FB2550 Instrument.

- Follow these sections to configure the Communication Data String Protocol.
- The **MODE** selection configures the **Network (Continuous)** or **Network (Auto)**.
- The final step of the IP Configuration is assigning the communication parameters for the device on the Network.

1. While in the **CONFIGURE OUTPUTS** menu, select **IP SETUP**.

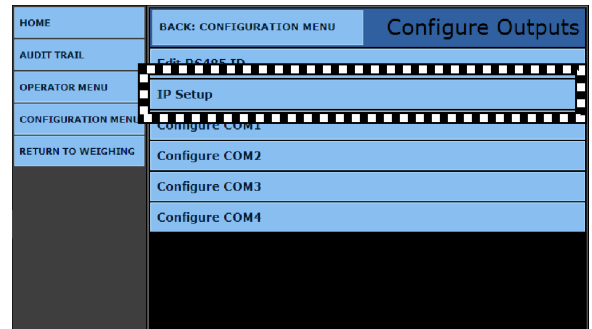

2. The **IP SETUP** configuration screen has several parameters to program.

- The **Local Port** can be a random number which is assigned to the FB2550 Instrument.
- Port numbers are values from 0 to 65535.
- Ports **0** to **1024** are reserved for certain privileged services.
- The combination of **Port Number** and **IP Address** is called a **SOCKET**.
- The **LOCAL PORT** and **REMOTE PORT** values should match.

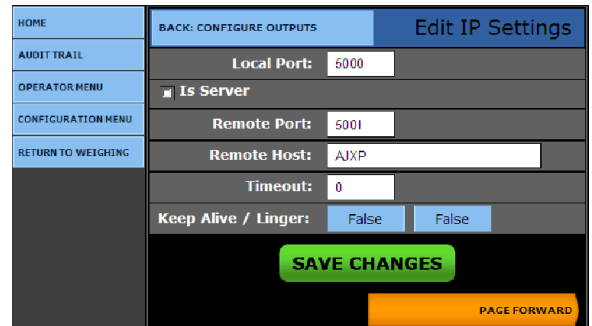

✓ **Default = 5001**

- The **Remote Port**: looks for information to forward to the **Remote Host**: (remote device name) application.
- The **Timeout**: function is to stop communications when it is inactive.

The **Keep Alive / Linger** settings will act as a means to keep the connections active even when activity is limited.

3. Press **PAGE FORWARD** once.

- The settings shown assist with networks which have active firewalls, and permit the IP communications to continue operating, instead of becoming blocked by the networks firewall settings.

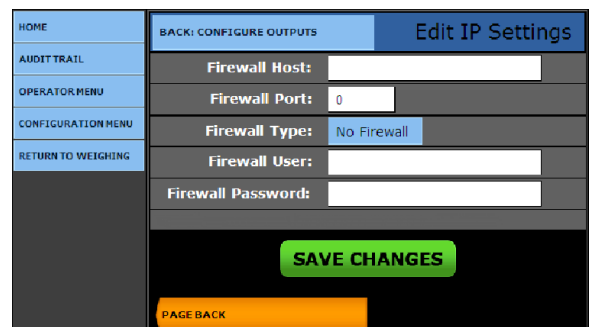

- Press the **SAVE CHANGES** button when any changes are made otherwise the changes will be lost.

8.8. RS-485 Configuration

The RS-485 output is available from the **RS-485 accessory (30937)**, or from the **Serial Expansion accessory (30921)**.

- Refer to Section 8.8.3. Method 1 – Preconfigured Output or Section 8.8.4. Method 2. – Customizing Output Data Strings.
- These sections describe how to configure the data string protocol for the communications.
- The final step for the RS-485 configuration is to assign an ID for the RS-485 communications network.
- This address is a requirement for proper operation.

Follow these steps to configure the RS-485 ID.

1. While in the **CONFIGURATION MENU**, press **PAGE FORWARD** once.
2. Press **CONFIGURE OUTPUTS**.

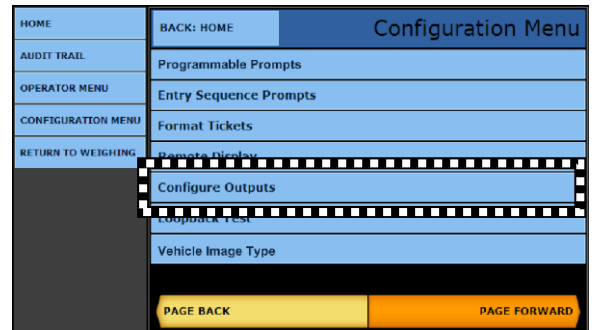

3. Select **EDIT RS-485 ID** to edit this option.

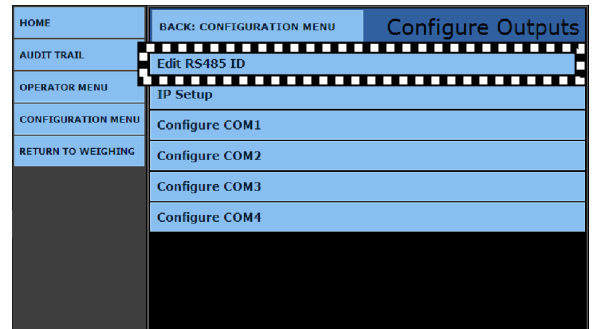

4. In the **RS-485 ID** field, enter the ID value, from **1** to **32**.

NOTE: A **ZERO (0)** disables this feature.

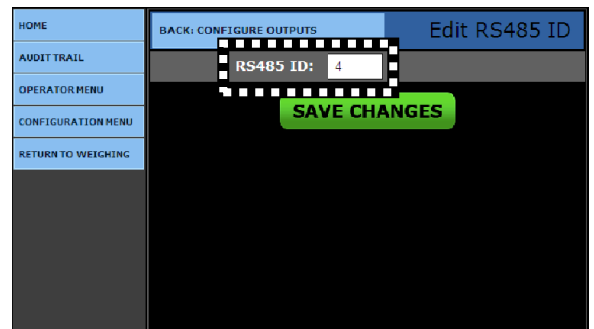

- Press the **SAVE CHANGES** button when any changes are made, otherwise they will be lost.

8.9. Network Parameters Configuration

The **Network Name**: is a unique identifier of the instrument as it appears on the Network to which it connects.

- Configure the **NETWORK TYPE** as a Static or Fixed IP, and either DHCP or Dynamic IP Addresses.
- The **IP ADDRESS** and **SUBNET MASK** are unique address values designed to function within the Network for which it is configured.
- IP Address is an identifier for a computer or device on a TCP/IP Network. Networks using the TCP/IP Protocol route messages based on the IP Address of the destination.

A **SUBNET MASK** is a local division of a **Local Area Network (LAN)**, which is created to improve performance and provide Network security.

1. While in the **CONFIGURATION MENU**, press the **PAGE FORWARD** button *twice*.
2. Select the **NETWORK PARAMETERS** option.

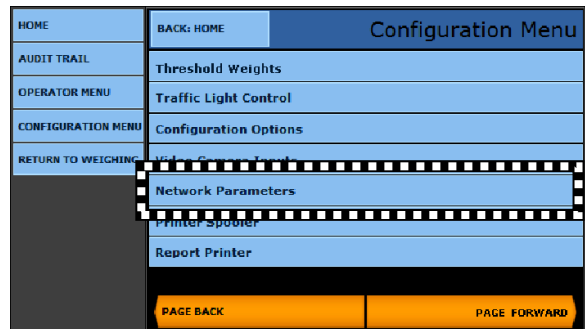

3. Click the **NETWORK TYPE** button.

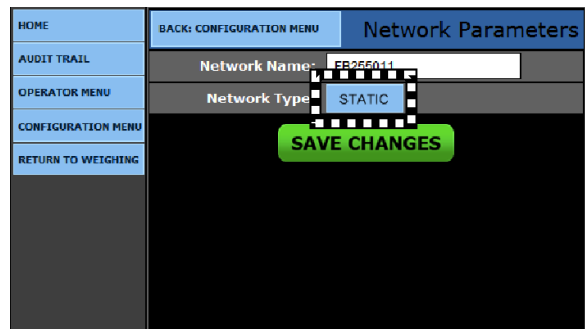

8.9. Network Parameters Configuration, Continued

4. Select either **STATIC IP** or **DHCP**.
 - If **cable is connected** upon initial Power Up and Configuration, the Network type selection will default to **STATIC**.
5. For **STATIC IP**, enter the correct **IP Address, Subnet Mask, Default Gateway** and **DNS Server Addresses**.

HOME	BACK: CONFIGURATION MENU	Network Parameters	
AUDIT TRAIL	Network Type:		CANCEL
OPERATOR MENU	Static IP		
CONFIGURATION MENU	DHCP		
RETURN TO WEIGHING			

- Press the **SAVE CHANGES** button, or they will be lost.

HOME	BACK: CONFIGURATION MENU	Network Parameters	
AUDIT TRAIL	Network Name:		FB2550
OPERATOR MENU	Network Type:		Static IP
CONFIGURATION MENU	IP Address:	192	168 1 1
RETURN TO WEIGHING	Subnet Mask:	255	255 255 0
	Default Gateway:	192	168 2 2
	DNS Server:	0	0 0 0
	SAVE CHANGES		

IMPORTANT NOTE: *The instrument **must be rebooted** for any Network changes to take effect.*

8.10. Fieldbus Protocols and Formats

8.10.1. Transmission Methods

Communication protocols are similar to conversations; there are several different languages and methods used.

- **PROFIBUS-DP, MODBUS-TCP, INTERBUS-S, and ETHERNET/IP** use a method called "**source-destination**" communications. The message packets have destination information in them, and the Fieldbus passes a token from node to node in a timed fashion.
- **DEVICENET, CONTROLNET, and CAN** use a **broadcast, producer-consumer model for communications**. Messages are broadcast to all nodes, and each node only "hears" messages intended for it.

8.10.2. Communication Format

Another major difference among Fieldbuses is the format of the communications themselves.

- **DEVICENET** and **CAN** messages are eight bytes long.
- **PROFIBUS-DP** is "word-oriented", and can have up to **256-byte** "stack" per message.

COSTS vs. SPEED

- **PROFIBUS-DP** and **CONTROLNET** are very fast networks – **12 megabits per second** and **500 Mb/s**, respectively. They are much more expensive to operate.
- **DEVICENET** is less expensive.

8.10.3. Handling Network Traffic

FIELDBUSES also handle network traffic in different ways.

- **DEVICENET** and **CAN** use "**non-destructive bitwise arbitration**." When two messages collide, the higher priority message goes first. If the two are equal priority, there is a mechanism within DeviceNet (as well as CAN) that decides which one should go first.
- When a collision occurs in **ETHERNET**, all devices "back off" and re-send their messages, which results in slower transmissions.

SECTION 9: ACCESSORIES

9.1. Accessory Parts List

9.1.1. Printers and Accessories

SERIAL PRINTERS

33292	EPSON TM-U220 DOT MATRIX PRINTER
29260	– Ribbon
30954Q	EPSON TM-U230 MATRIX PRINTER
29260	– Ribbon
24741	EPSON TM-U295 TICKET PRINTER
14979	– Ribbon
96757	– Scale ticket, 2 part
96756	– Scale ticket, 3 part
16288	– Scale ticket, 4 part
24740	EPSON TM-U590 TICKET PRINTER*
24810	– Ribbon Cartridge
32403	EPSON EU-T432 THERMAL TAPE PRINTER
32404	– Paper
20481	CITIZEN iDP3550 PRINTER
95952	– Ribbon
11535	– Paper Roll Tape, 3”X3”, 1 Ply
N/S	STAR SP298 TICKET PRINTER
N/S	STAR SP700 IMPACT PRINTER
N/S	STAR SP2000 IMPACT PRINTER
N/S	STAR SP2200 TICKET PRINTER

USB PRINTERS

33220	XEROX PHASER 3040 LASER JET PRINTER
29827C	– 6’ Hi-Speed USB 2.0 A-to-B Cable (Specify on order – N/C with printer)
19946	ML 420 SERIES PARALLEL/ USB FORM PRINTER
96799	– Blank 4-part Tickets
96801	– Blank 2-part Tickets
N/A	HP2055 LASER JET PRINTER

PRINTER ACCESSORIES

32674	EPSON POWER SUPPLY
14809	SERIAL CABLE
25932	SERIAL CABLE

* Uses the same tickets as the **TM-U295**.

N/S – Not Sold by Fairbanks Scales.

N/A – Not Available.



9.1.2. Additional Accessories

32426	LOOP DETECTOR KIT
31866	FILTERED COOLING FAN KIT
10-4002-009	TRANSCORE RFID SCANNER
25498	EXTERNAL MINI KEYBOARD – USB 87-KEY
31036	EXTERNAL KEYBOARD – USB 104-KEY

CAMERA AND ACCESSORIES

31080	OUTDOOR IP CAMERA AND POLE ADAPTER
32373	– <i>Pole Adapter Plate for Video Camera</i>
15808	– <i>Pole Adapter Plate Mounting Clamps (3" Pole)</i>
15809	– <i>Pole Adapter Plate Mounting Clamps (4" Pole)</i>
15810	– <i>Pole Adapter Plate Mounting Clamps (5" Pole)</i>

9.2. Programming the Traffic Light Control

The **TRAFFIC LIGHT CONTROL** shows the status of the scale’s traffic light. It is typically controlled automatically by the instrument weightment cycle.

The light has a manual override using the touch screen on the main weighing display.

Each of the **two (2) I/O RELAY CARDS** supports **two (2)** sets of lights, totaling **four (4) Stop Light Units**.

Follow these steps to configure the Traffic Light Control.

1. While in the **WEIGH SCREEN**, press the **MENU** button.
2. Press **LOGIN**.
3. Enter the **Write Customer Password** or **Service Password**, then press the **LOGIN** button.
4. Open the **CONFIGURATION MENU**.
5. Press **PAGE FORWARD** twice.
6. Select **TRAFFIC LIGHT CONTROL**.
7. Select **SCALE ID X TRAFFIC CONTROLS**.

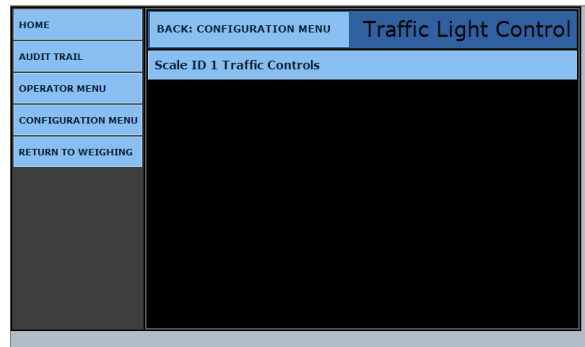
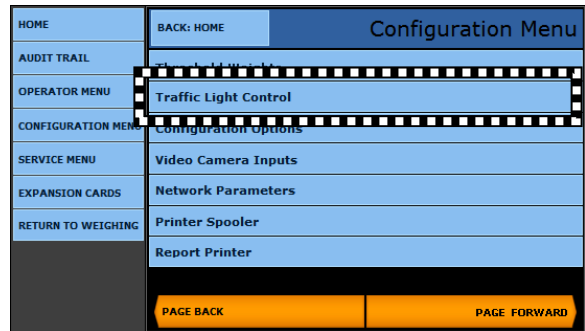

9.2. Programming the Traffic Light Control, Continued

8. Select the **TRAFFIC LIGHT CONTROL** button to one of the following options.
 - Disabled
 - 1 – Traffic Light
 - 2 – Traffic Lights
9. In the second button to the right, select whether the **Traffic Lights** operate in a **MANUAL** or **AUTOMATIC** mode.

HOME	BACK: TRAFFIC LIGHT CONTROL	Traffic Light: Scale1	
AUDIT TRAIL	Traffic Light:	Disabled	Automatic
OPERATOR MENU	Barrier/Gate:	Disabled	Automatic
CONFIGURATION MENU	Loop Detector:	Disabled	
RETURN TO WEIGHING	Zero on Approach:	No	
	Inhibit if Active:	No	
	Complete Cycle:	No	
<div style="background-color: green; color: white; padding: 5px; display: inline-block; margin-right: 20px;">SAVE CHANGES</div> <div style="background-color: orange; color: black; padding: 5px; display: inline-block;">PAGE FORWARD</div>			

HOME	BACK: TRAFFIC LIGHT CONTROL	Traffic Light: Scale1
AUDIT TRAIL	Traffic Light: CANCEL	
OPERATOR MENU	Disabled	
CONFIGURATION MENU	1-Traffic Light	
SERVICE MENU	2-Traffic Lights	
EXPANSION CARDS		
RETURN TO WEIGHING		

HOME	BACK: TRAFFIC LIGHT CONTROL	Traffic Light: Scale1
AUDIT TRAIL	Traffic Light: CANCEL	
OPERATOR MENU	Automatic	
CONFIGURATION MENU	Manual	
SERVICE MENU		
EXPANSION CARDS		
RETURN TO WEIGHING		

10. **BARRIER/GATES** control is used to control the **Traffic Gates**.

HOME	BACK: TRAFFIC LIGHT CONTROL	Traffic Light: Scale1
AUDIT TRAIL	Barrier/Gate: CANCEL	
OPERATOR MENU	Disabled	
CONFIGURATION MENU	1-Barrier/Gate	
SERVICE MENU	2-Barriers/Gates	
EXPANSION CARDS		
RETURN TO WEIGHING		

HOME	BACK: TRAFFIC LIGHT CONTROL	Traffic Light: Scale1
AUDIT TRAIL	Barrier/Gate: CANCEL	
OPERATOR MENU	Automatic	
CONFIGURATION MENU	Manual	
SERVICE MENU		
EXPANSION CARDS		
RETURN TO WEIGHING		

9.2. Programming the Traffic Light Control, Continued

11. Select the **LOOP DETECTOR** control button.

- **Sensor Loops** alert that the vehicle has entered the scale, and also that it is leaving.

12. Select the correct **Loop Detector**.

- Extra **LOOP** choices (*i.e.* 3- Loop, 4-Loop) appear when the *second* optional **Relay Card (30920)** is added to the Instrument.

13. Select the **ZERO ON APPROACH** Control button.

- Driver pulls up and stops on the Loop.
- The scale ZEROs, and the traffic light changes to green, signalling the driver to pull ahead.

14. Choose **NO** or **YES**.

15. Select the **INHIBIT IF ACTIVE** Control button.

16a. Selecting **YES** will *NOT* allow a weighment to be processed if a Loop Detector is “**active**”.

- This ensures that a truck is fully scale-borne before a weight can be processed. Trucks which are in succession cannot stop on the top of the loops, or the weighment transaction will not be permitted.

OR...

16b. Select **NO** to allow a transactions to be processed, even if a the vehicle is still detected at the loop.

- **COMPLETE CYCLE** is a feature to be used in the future with the **Axlematic Application**.

HOME	BACK: TRAFFIC LIGHT CONTROL	Traffic Light: Scale1
AUDIT TRAIL	Traffic Light:	Disabled Automatic
OPERATOR MENU	Barrier/Gate:	Disabled Automatic
CONFIGURATION MENU	Loop Detector:	Disabled
RETURN TO WEIGHING	Zero on Approach:	No
	Inhibit if Active:	No
	Complete Cycle:	No
	SAVE CHANGES	
	PAGE FORWARD	

HOME	BACK: TRAFFIC LIGHT CONTROL	Traffic Light: Scale1
AUDIT TRAIL	Loop Detector:	CANCEL
OPERATOR MENU	Disabled	
CONFIGURATION MENU	1-Loop	
SERVICE MENU	2-Loops	
EXPANSION CARDS		
RETURN TO WEIGHING		

HOME	BACK: TRAFFIC LIGHT CONTROL	Traffic Light: Scale1
AUDIT TRAIL	Zero on Approach:	CANCEL
OPERATOR MENU	No	
CONFIGURATION MENU	Yes	
SERVICE MENU		
EXPANSION CARDS		
RETURN TO WEIGHING		

9.2. Programming the Traffic Light Control, Continued

16. Press the **SAVE CHANGES** button when any changes are made, or they will be lost.

17. Press **Page Forward**.

18. To the right of the **Event to Signal:**, select **TIME DELAY OF X SECONDS** Control button.

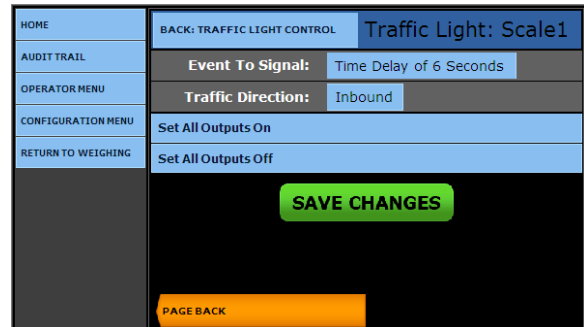

19. Click on the correct time value.

- This is the time delay from when the truck enters the scale.

✓ **DEFAULT = 6 SECONDS**

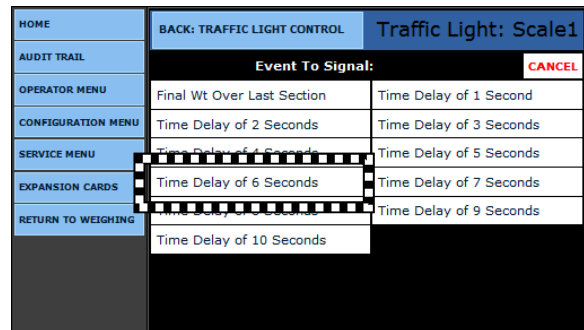

20. Select the **TRAFFIC DIRECTION** Control button.

- This selects which way the vehicles will normally be traveling.

21. Select either **INBOUND** or **OUTBOUND**.

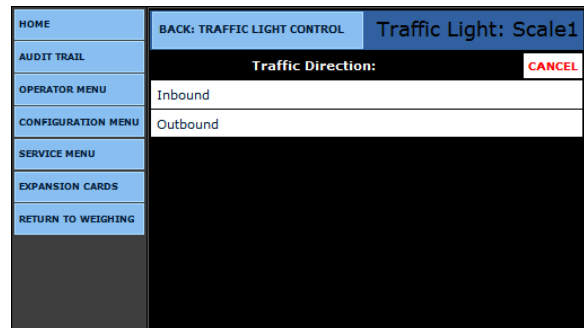

22. Select either the **SET ALL OUTPUTS ON** or the **SET ALL OUTPUTS OFF** Control Button.

- Activates or deactivates the Traffic Lights for troubleshooting.

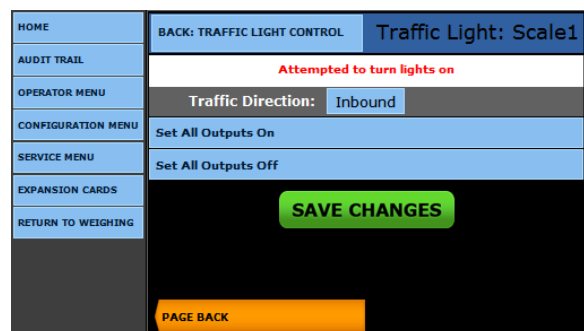

- Press the **SAVE CHANGES** button, or they will be lost.
- Select **BACK: TRAFFIC LIGHT CONTROL** to return to the previous menu.

9.3. Video Camera Programming

1. While in the **WEIGH SCREEN**, press the **MENU** button.
2. Select **LOGIN**, then enter the **Write Customer Password** or **Service Password**.
3. Press the **LOGIN** button.
4. Open the **CONFIGURATION MENU**.
5. Press **PAGE FORWARD** twice.
6. Select **VIDEO CAMERA INPUTS**.

The FB2550 has **two (2) IP video camera inputs**.

- These can be stored with the Transaction Data
 - They can be displayed on the Instrument's **Weigh Screen, Idle Screen**: setting, in various ways.
7. To activate this feature, select **YES** to one or both of the **CAMERA 1** or **2 ENABLED** options.
 8. Select the **CAMERA 1** or **2 TYPE**.
 9. Enter the **CAMERA 1** or **2 IP** address.
 10. Press **PAGE FORWARD**.

11. Select either **NONE, CAMERA 1, CAMERA 2, or TOGGLE** for each of the button options listed below.

- The video camera can toggle between the two cameras or display them individually.

- Idle Screen
- Store Trans
- Print Ticket
- Select Screen
- Store Blind Ctr (Control)
- File Format

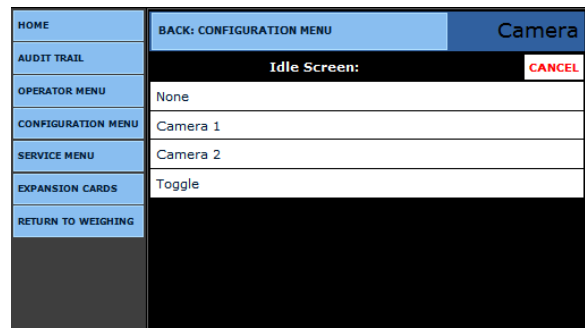
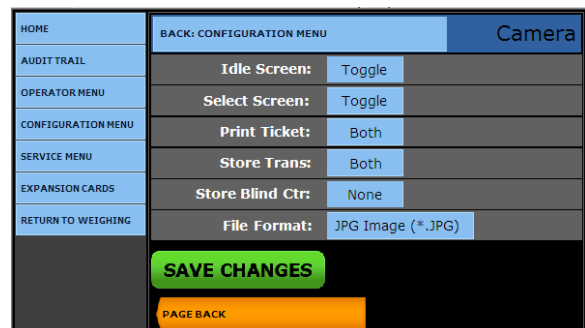
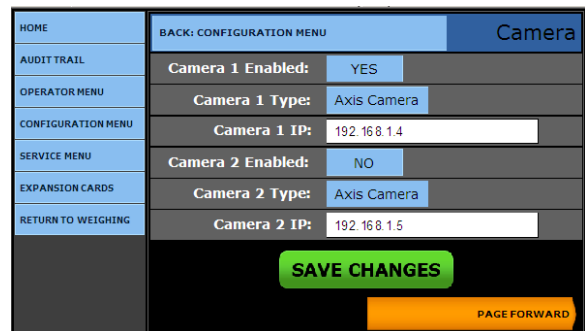
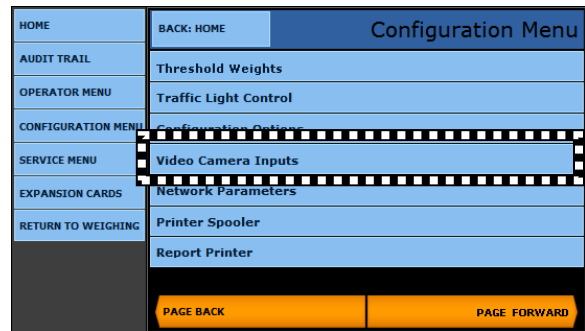

9.3. Video Camera Programming, Continued

12. In the **File Format** option, save the images in either a **PDF** or **JPG** file format.

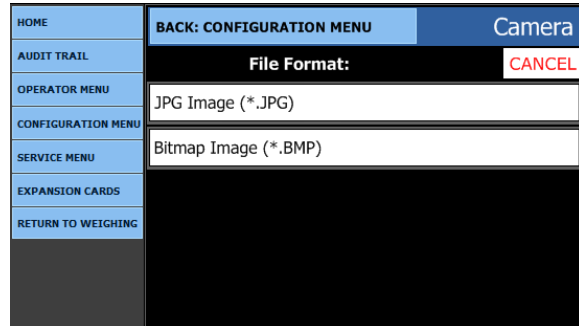

- Press the **SAVE CHANGES** button, or they **will be lost**.
- Select **BACK: CONFIGURATION MENU** to return to the previous menu.

9.4. External Display (Dual Cloning)

The following section details how to install an **External Display** for **Dual Cloning** of the Instrument.

- The FB2550 out of the box is setup to recognize one (1) Display/ Built-in LCD.
- Sites/Customers may want cloning to enhance viewing of a larger display, yet still keep the instrument locally usable.

Install these two components to set up **Dual Cloning**, or to fix a screen shift from the previous dual cloning.

- **USB Auxiliary Keyboard** (to send hotkey sequences)
- **External VGA Display**

9.4.1. Standard Setup

Follow these steps to configure an Instrument with Dual Displays.

1. Press **CTRL+ALT+F12**.
 - The **Intel® Graphics Media** window appears.
2. From the **left column**, open the **DISPLAY DEVICES** tab.
3. From the **MULTIPLE DISPLAY** radio options, select **Intel (R) Dual Display Clone**.
4. Click **APPLY**.

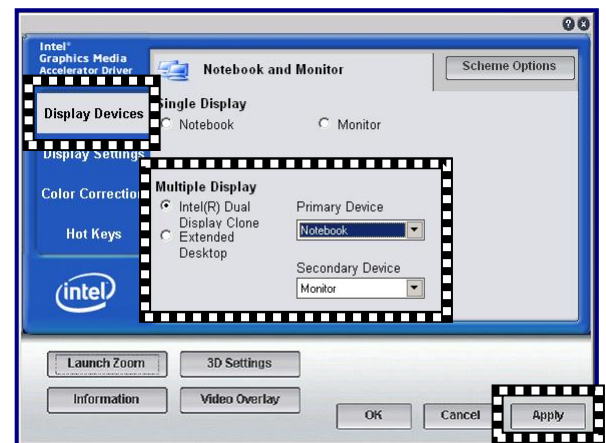

5. When the pop-up notice appears, click **OK** to confirm the new settings.



NOTE: After completing this **STANDARD SETUP** procedure , the **External Display** should be programmed and function correctly.

- The following page details the standard defaults of the **DISPLAY SETTINGS** tab.

9.4.2. Display Settings Defaults

1. From the left column, open the **Display Settings** tab.
2. In the **Color Quality** drop-down menu, select **32 Bit**.
3. In the **Screen Resolution** drop-down menu, select **800 x 480**.
4. In the **Refresh Rate** drop-down menu, select **60 Hertz**.
5. Press the **ASPECT RATION OPTIONS** button.

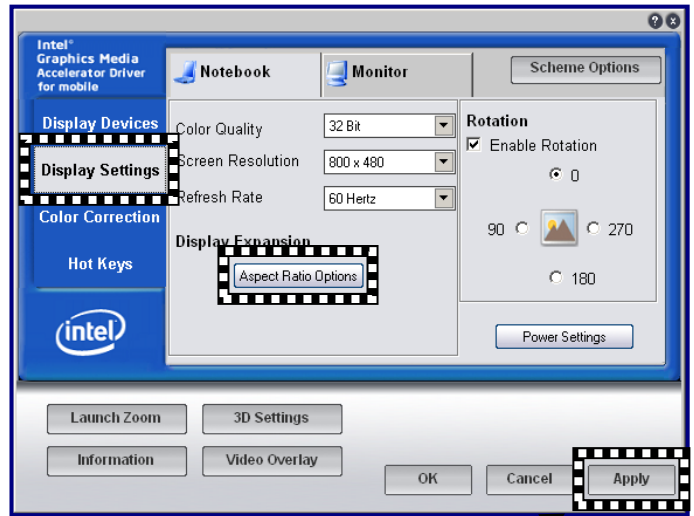

6. Select **Full Screen (No Border)**.
7. Press the **APPLY** button.
8. Press the **OK** button.
 - Doing this returns to the **Display Settings** tab of the Intel® Graphics Media window.

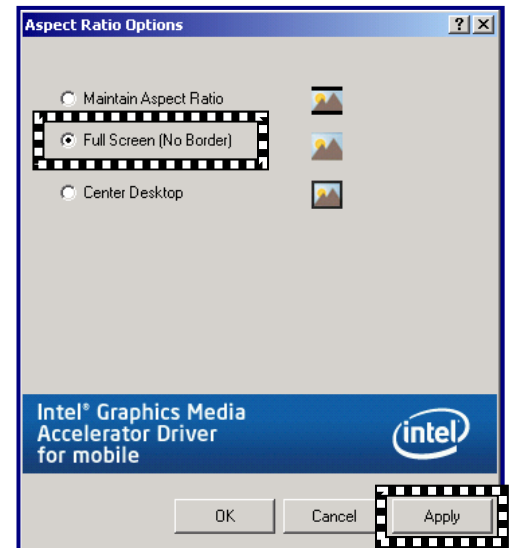

9. In the **Display Settings** tab, press the **APPLY** button.

10. When the pop-up notice appears, click **OK** to confirm the new settings.



9.4.3. Disabling the External Display

Follow these steps to **disable** the external display, once it has been activated.

1. Press **CTRL+ALT+F12**.
 - The **Intel® Graphics Media** window appears.
2. In the **SINGLE DISPLAY** radio options, select **NOTEBOOK**.
3. Click **APPLY**.

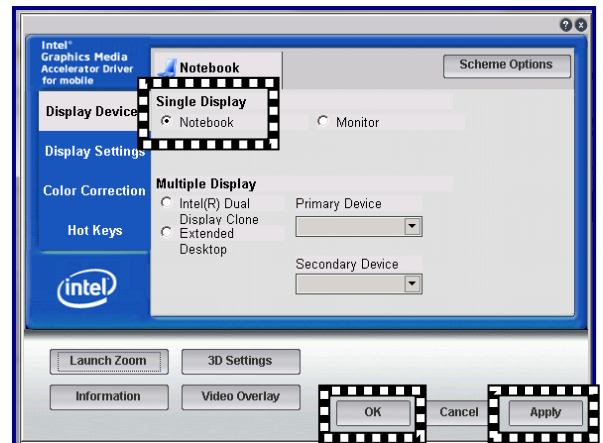

4. When the pop-up notice appears, click **OK** to confirm the new setting.



9.4.4. Restoring the Display with an External Keyboard

If the external screen is unreadable, or if screen calibration is inaccurate, navigating with the touch screen may be impossible.

- Be certain the external screen and keyboard are securely installed.

Follow these steps to **restore the display** on the FB2550 Instrument using the external keyboard.

1. Press the **TAB key** thirteen (13) times.
 - The cursor should be in the **Multiple Displays** region of **Display Devices**.
- 2a. Either press the **DOWN arrow** two (2) times.
 - This changes the **Single Display Notebook** to **Multiple Display Clone**.

OR...

- 2b. If **Dual Cloning** feature is already actively running on the displays, press the **TAB key** thirteen (13) times.

3. Press the **DOWN arrow** once(1).
4. Press the **TAB key** four (4) times.
 - The cursor should be at **Screen Res** option.
5. Press the **DOWN arrow** to select 800x480.
 - Pressing the **DOWN arrow** two to three (2-3) times will be the last value.
6. Press the **TAB key** ten (10) times.
7. Press the **Space bar**.
 - The cursor should be at the **APPLY button**.

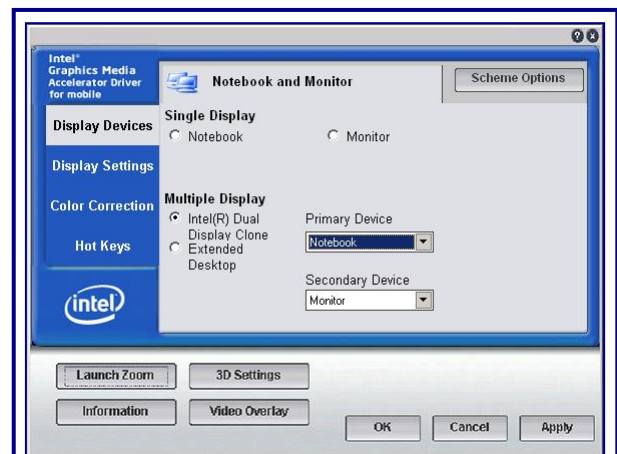

When the external monitor is unreadable, these steps restore the default display settings with the external keyboard.

8. Press the **Space bar** again to accept the settings.
9. Press the **LEFT arrow** two (2) times.
 - The cursor should be at the **OK button**.
10. Press the **SPACE BAR**.
11. When the pop-up notice appears, click **OK** to confirm the new settings.
 - This exits the **Intel® Graphics View** program



SECTION 10: SERVICE & MAINTENANCE

10.1. Database Maintenance

10.1.1. Database Backup

The FB2550 Instrument has **three (3) methods** of database backup routines.

A. BACKUP DATABASE TO FLASH – Backs up the database to the **micro SD card** located on the Multi-Function board.

B. BACKUP DATABASE TO EXTERNAL FLASH – Backs up the database to a USB Flash drive, inserted into an available USB port on the instrument rear panel.

C. BACKUP AND SEND AN EMAIL – Backs up the database and attach the file to an email, which is sent to a predetermined user.

D. BACKUP TICKET FORMAT TO FLASH – Backs up changes in the ticket format to the internal memory.

E. BACKUP TICKET FORMAT TO EXTERNAL FLASH – Backs up changes in the ticket format to the external, removable memory drive.

NOTE: Backups can only be used if they are within the same revision family.

Example: Rev. 4.1 to 4.2 is **OK**. Rev. 3.5 to 4.0 is **NOT OK**.

10.1.1. Database Backup, Continued

A. BACKUP DATABASE TO FLASH [INTERNAL]

1. While in the **Weight Screen**, press the **MENU** button.
2. Press **LOGIN**.
3. Enter the **Write Customer Password** or **Service Password**.
4. Press the **LOGIN** button.
5. Select **CONFIGURATION MENU**.
6. Select **DATABASE MAINTENANCE**.
7. Select **BACKUP DATABASE TO FLASH**.

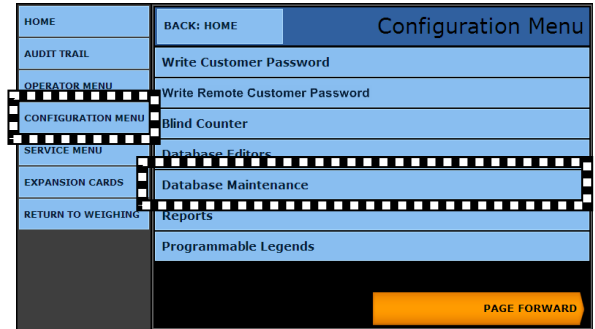

8. Select either the **CONTINUE** or the **CANCEL** button.
 - When the **BACKING UP** process is performed, integrity of the currently used data is **VERIFIED** against the backup.
 - The database is completely erased and prepared for new transaction data.

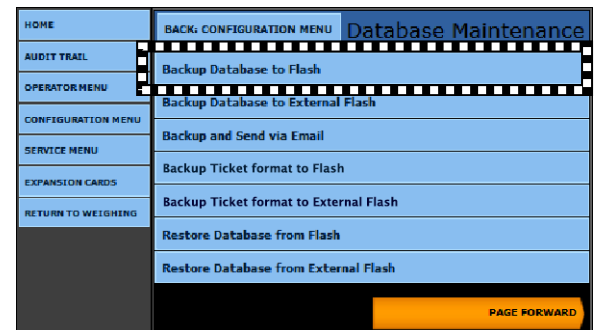

9. Once the **Backup** is complete, press the **CONTINUE** button to return to the **Database Maintenance Menu**.

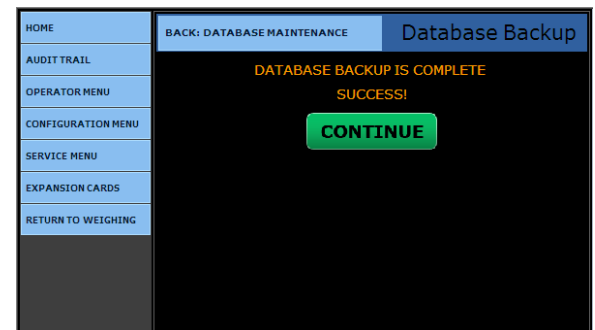
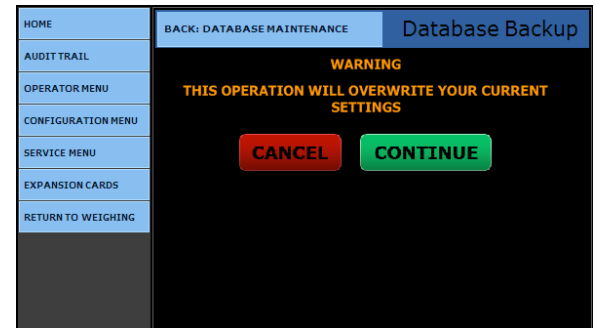

10.1.1. Database Backup, Continued

B. BACKUP DATABASE TO EXTERNAL FLASH

1. Insert a **USB FLASH DRIVE** into an available port on the Instrument's rear panel.

2. While in the **CONFIGURATION MENU**, select **DATABASE MAINTENANCE**.

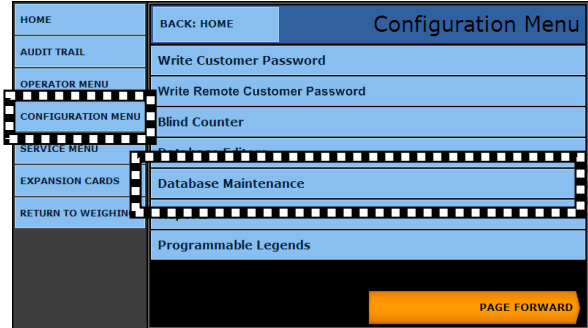

3. Select **BACKUP DATABASE TO EXTERNAL FLASH**.

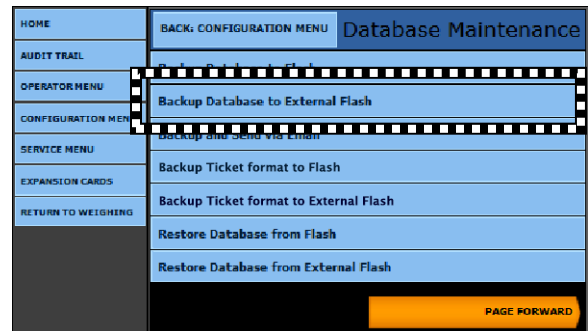

4. Select either **CONTINUE** or **CANCEL**.

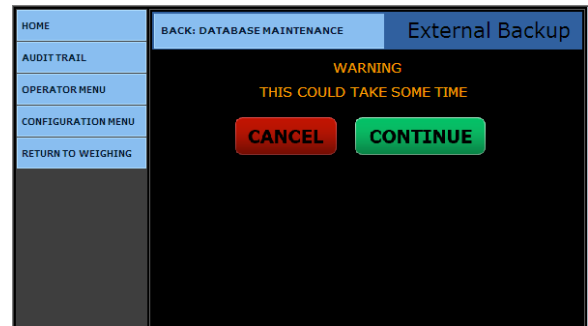

5. After completing the **External Backup**, press the **CONTINUE** button to return to the **Database Maintenance** menu.

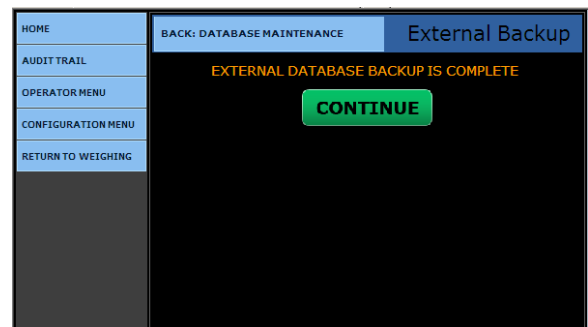

6. Remove the **USB FLASH DRIVE**.

10.1.1. Database Backup, Continued

C. BACKUP AND SEND AN EMAIL

1. While in the **CONFIGURATION MENU**, select **DATABASE MAINTENANCE**.

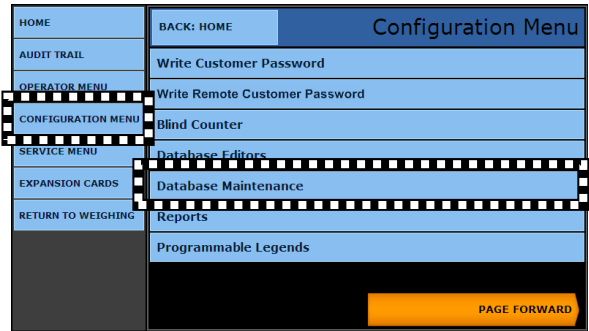

2. Select **BACKUP AND SEND VIA EMAIL**.

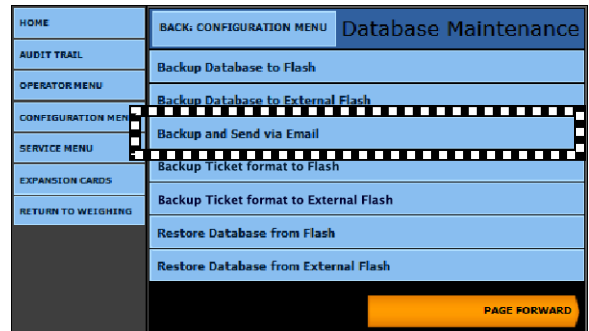

3. Select either **CONTINUE** or **CANCEL**.

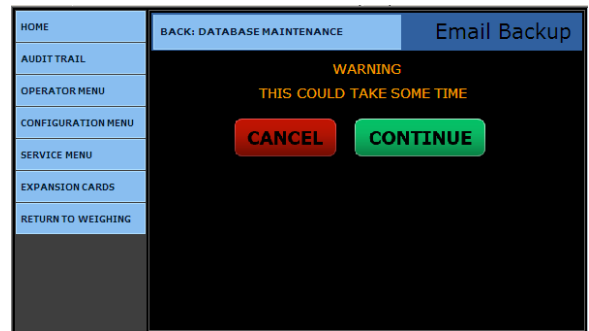

4. After completing the **External Backup**, press the **CONTINUE** button to return to the **Database Maintenance** menu.

5. Remove the **USB FLASH DRIVE**, if one is used.

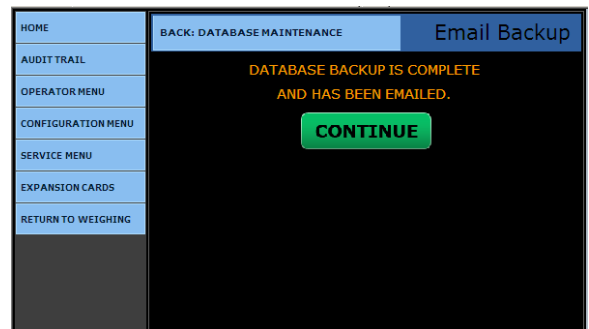

- Press **RETURN TO WEIGHING** to exit to the Weigh Processing screen.

10.1.1. Database Backup, Continued

D. BACKUP TICKET FORMAT TO FLASH – Backs up changes in the ticket format to the internal memory.

1. While in the **CONFIGURATION MENU**, select **DATABASE MAINTENANCE**.

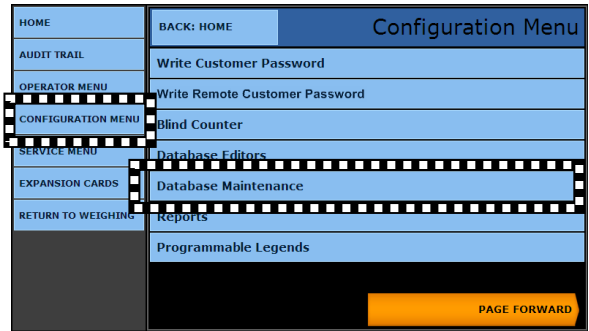

2. Select **BACKUP TICKET FORMAT TO FLASH**.

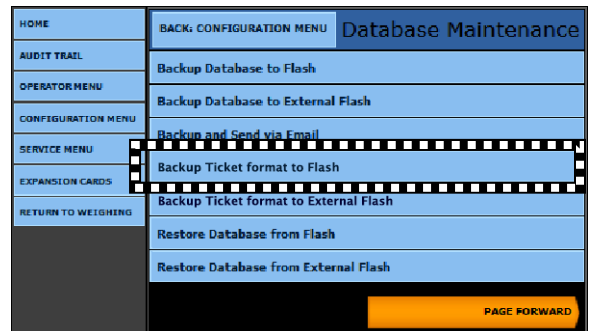

3. Press **CONTINUE** to complete the operation.

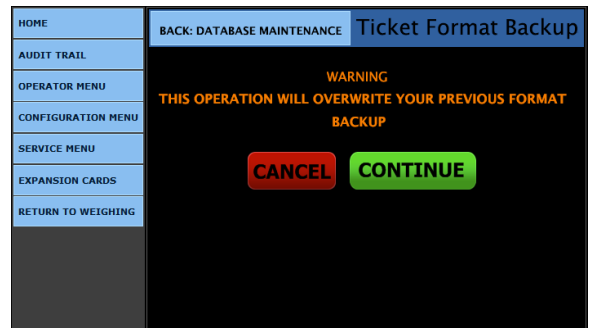

4. Press **CONTINUE** to finish the process.

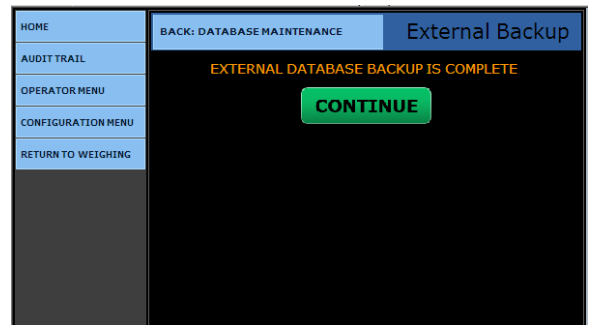

10.1.1. Database Backup, Continued

E. BACKUP TICKET FORMAT TO EXTERNAL FLASH – Backs up changes in the ticket format to the external, removable memory drive.

1. While in the **CONFIGURATION MENU**, select **DATABASE MAINTENANCE**.

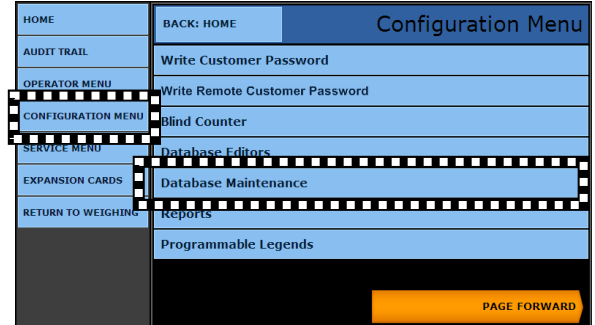

2. Select **BACKUP TICKET FORMAT TO FLASH**.

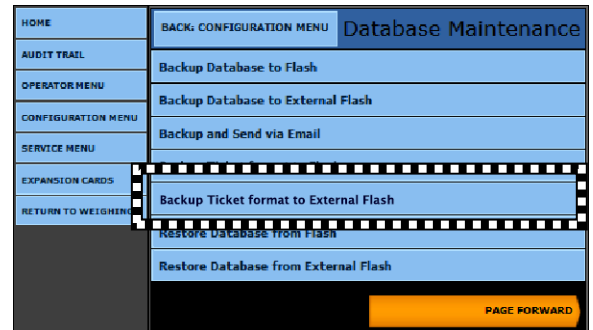

3. Press **CONTINUE** to complete the operation.

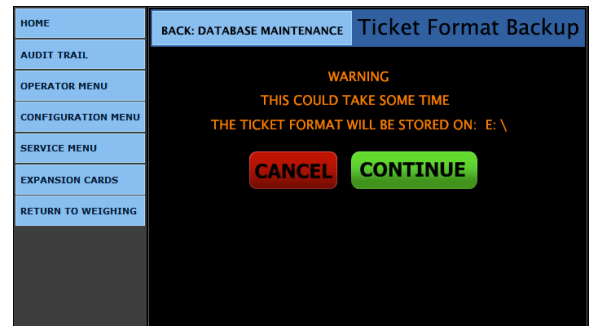

4. Press **CONTINUE** to finish the process.

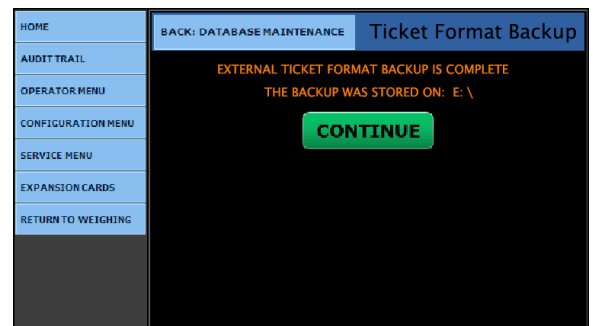

10.1.2. Database Restore

RESTORE DATABASE FROM FLASH uses a database backup from the **Micro SD Card**, located on the **Multi-Function Board**.

RESTORE DATABASE FROM EXTERNAL FLASH uses a database backup from an **External USB Flash Drive**.

- These two options restore the instrument’s database to the same condition as when the backup was performed previously.

A. RESTORING DATABASE FROM FLASH

1. While in the **CONFIGURATION MENU**, select **DATABASE MAINTENANCE**.
2. Press **RESTORE DATABASE FROM FLASH**.
3. Select either **CONTINUE** or **CANCEL**.
4. Once the process is complete, press the **CONTINUE** button to return to the **Database Maintenance** menu.

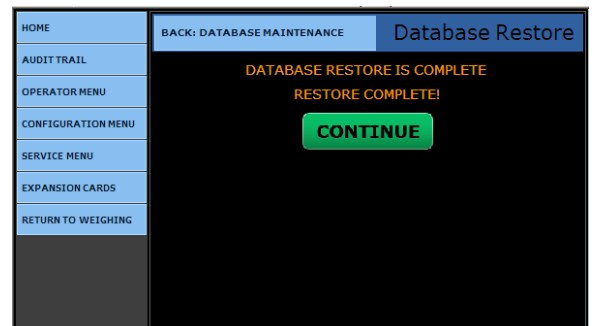
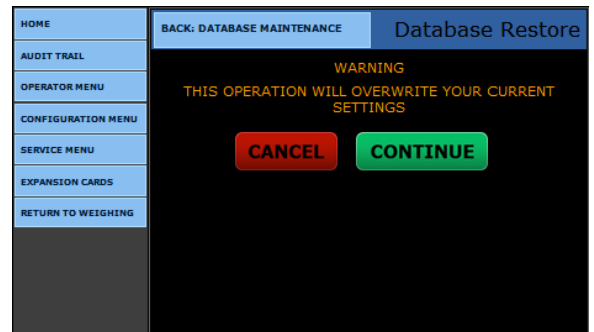
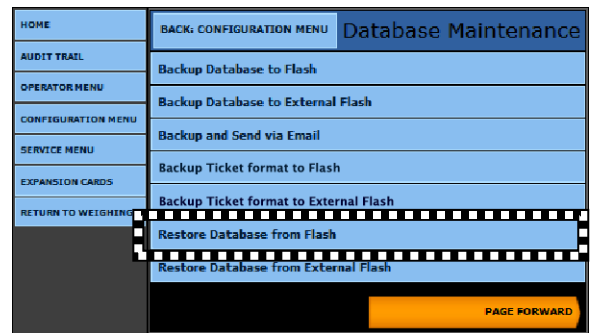
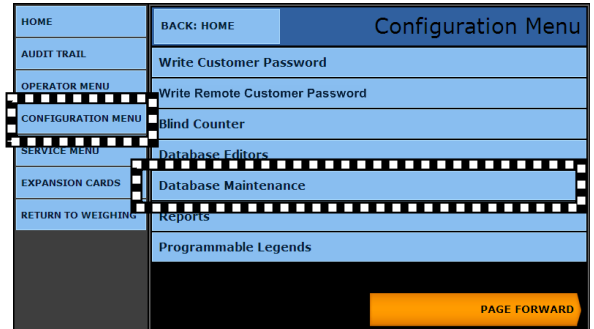

10.1.2. Database Restore, Continued

B. RESTORING THE DATABASE FROM EXTERNAL FLASH

1. While in the **CONFIGURATION MENU**, select **DATABASE MAINTENANCE**.

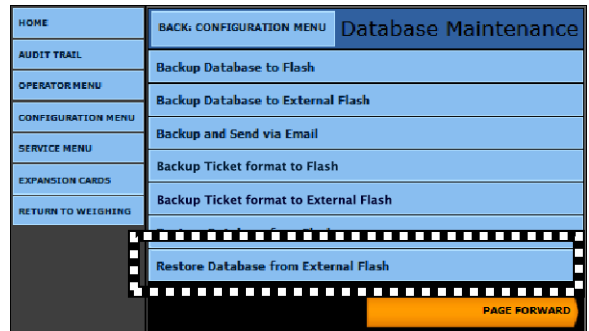

2. Select **RESTORE DATABASE FROM EXTERNAL FLASH**.

3. Select the correct **EXTERNAL RESTORE** file from the list.



4. Press **CONTINUE** button to complete the process, or press the **CANCEL** button to stop the procedure.
 - A warning displays to confirm the decision to proceed.
 - The **External Restore** process may take several minutes to complete.

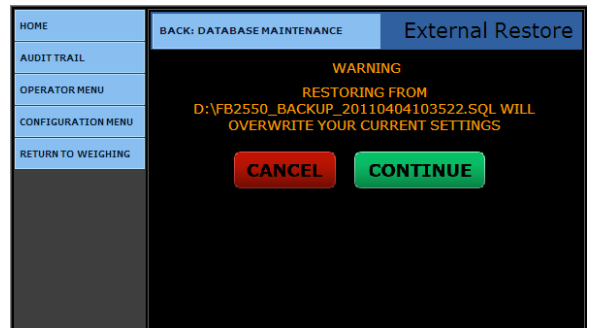

- When the **Database Restore** is complete, press the **CONTINUE** button to return to the **Database Maintenance** menu.

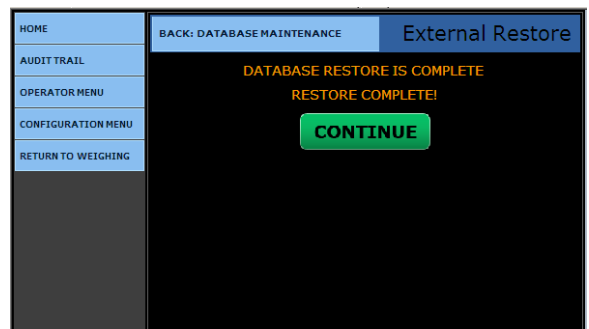

10.1.2. Database Restore, Continued

C. PROCEDURE RESTORE DATABASE FROM DEFAULTS

1. While in the **CONFIGURATION MENU**, select **DATABASE MAINTENANCE**.
2. Press **PAGE FORWARD** once.
3. Select **RESTORE DATABASE FROM DEFAULTS**.

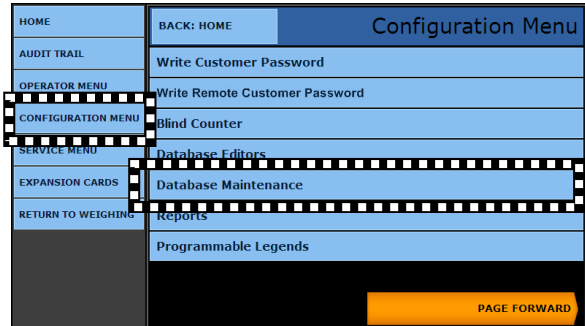

- A warning displays about whether or not to proceed.
 - The message will confirm that the correct backup file has been selected.
4. Press **CONTINUE** button to complete the process, or press the **CANCEL** button to stop the procedure.
 - This process could take several minutes.

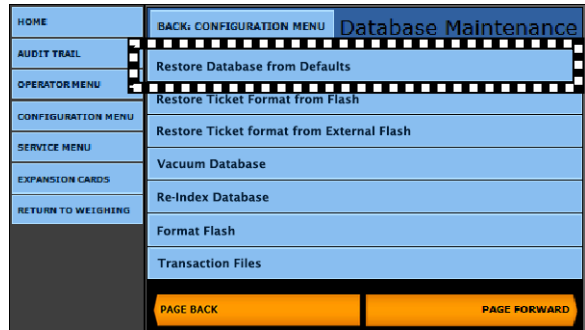

5. When the **Database Default Restore** process is complete, press the **CONTINUE** button to return to the **Database Maintenance** menu.

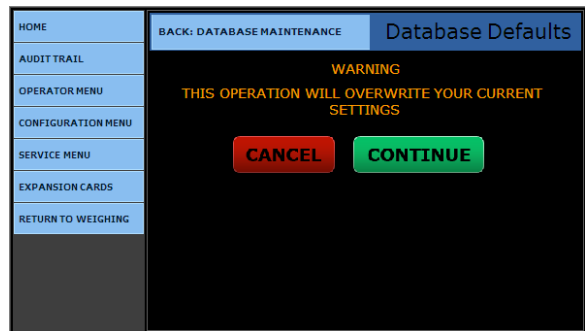

- Press **RETURN TO WEIGHING** to exit to the Weigh processing screen.

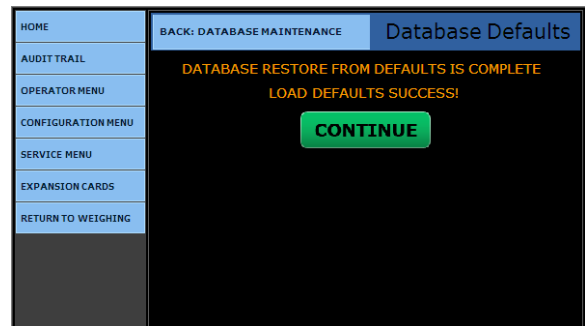

10.1.3. Re-Index Database

1. While in the **CONFIGURATION MENU**, select the **DATABASE MAINTENANCE MENU**.
2. Press **PAGE FORWARD** once.
3. Select **RE-INDEX DATABASE**.
 - A warning will display of whether or not to proceed.
 - This process could take several minutes.
4. Press **CONTINUE** button to complete the process, or press the **CANCEL** button.
5. When the **Database Re-Index** process is complete, press the **CONTINUE** button to return to the **Database Maintenance** menu.

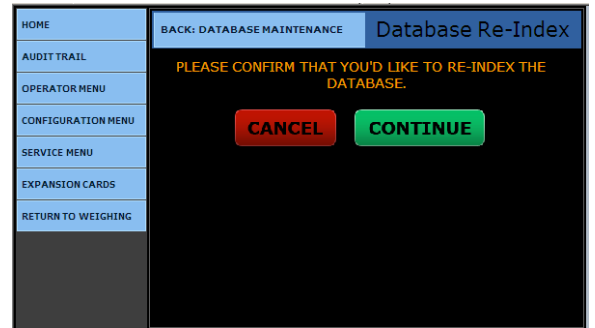
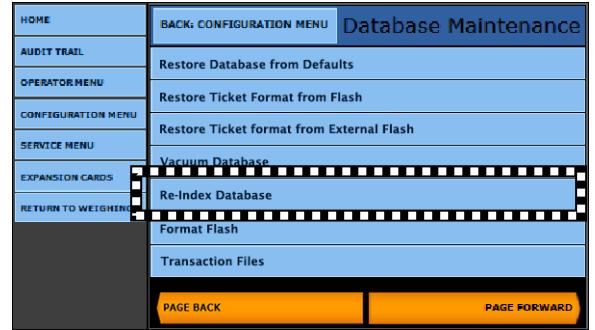

10.1.4. Transaction Data Backup Days Reminder

This option emails a reminder to update the database.

1. While in the **Weight Screen**, press **LOGIN**.
2. Enter the **Write Customer Password** or **Service Password**.
3. Press the **LOGIN** button.
4. Select **CONFIGURATION MENU**.
5. Press **PAGE FORWARD** twice.
6. Select **CONFIGURATION OPTIONS**.
7. Enter a numeral in the **Transaction Data Backup Days** input field.
 - This sets a timed reminder for the **Data Backup**.
 - A value of **0** disables this feature.
8. Press the **SAVE CHANGES** button, and the program returns to the **CONFIGURATION MENU** when complete.

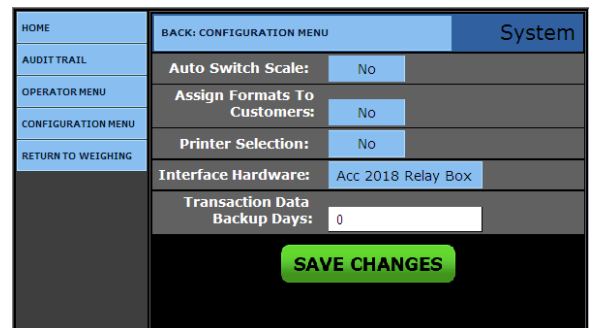
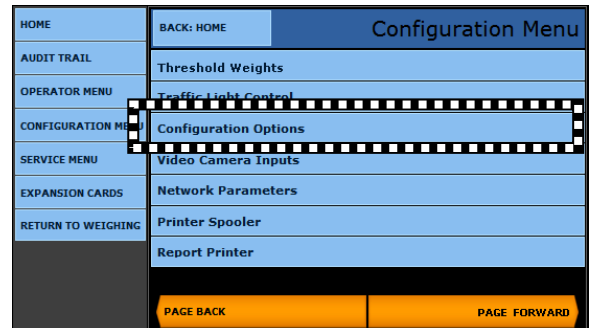

10.1.5. Completed TXN IMGS

This option allows the camera images to be viewed, emailed, deleted and copied to USB device.

1. While in the **CONFIGURATION MENU**, select **DATABASE MAINTENANCE**.

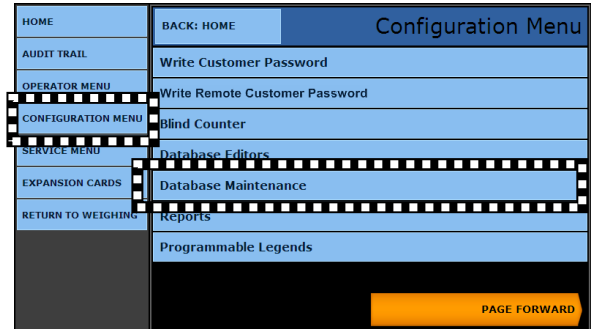

2. Press **PAGE FORWARD** twice.

3. Select **MANAGE COMPLETED TRANSACTION IMAGES**.

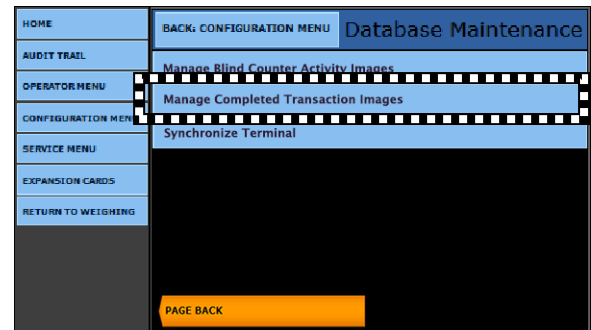

4. Select any of the following options.

- VIEW ALL
- VIEW BY TICKET NUMBER
- VIEW BY DATE RANGE
- VIEW BY TICKET NUMBER RANGE
- DELETE ALL
- DELETE BY DATE RANGE
- DELETE BY TICKET NUMBER RANGE

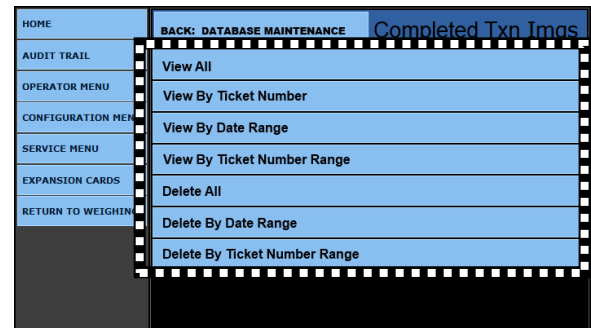

5. Select one of the following options.

VIEW displays the stored image.

EMAIL sends this image to any recipient within the database.

DELETE erases the image completely.

COPY TO USB DEVICE stores the image to a USB flash drive.



- Each image is **Time** and **Date Stamped** for security recording purposes.

- Pressing **CONTINUE** returns to the **COMPLETED TXN MSGS** menu.

10.2. Printer Troubleshooting

PAPER JAMS

When paper jams occur within one area of the printer, **unplug the power cable**, then clean that area of the paper path with alcohol and cotton balls.

The following can cause paper jams.

- Selecting incorrect paper type.
- Using unsupported paper.
- Overfilling the tray.
- Using creased, moist or damaged paper.
- Loading paper incorrectly.
- Adjusting the paper guides improperly.

Noted below are some preventative measures.

- Always use clean, undamaged paper.
- Always fan the paper.
- Observe the paper tray fill line.
- Avoid polyester coated paper (designed for inkjet or thermal-type printers).
- Adjust the guides correctly to fit the paper size.
- Store the printer and paper in a dry location.
- Select the correct paper size for printing.
- Use only XEROX® recommended paper.

NOTE: For complete printer descriptions, see **Section 8.1. Printers.**

DOES NOT TURN ON

PROBABLE CAUSE (S)	SOLUTION(S)
Switch not turned on.	Turn on switch.
Problem with outlet connections.	Test outlet, then resolve wiring issues. <ul style="list-style-type: none"> Plug it into a different outlet.

RESETS OR TURNS OFF FREQUENTLY

PROBABLE CAUSE(S)	SOLUTION(S)
Power cord is not connected firmly.	Turn off printer, then confirm the power cord is plugged in correctly, then turn on the printer.
System error occurred.	<ul style="list-style-type: none"> Reboot the printer. Print the ERROR HISTORY from the Information Pages of the Printer Setting Utility.
Printer connected to an UPS, or is connected to a power strip shared with other high-power devices.	Turn off the printer, then connect it to a more suitable outlet.

10.2. Printer Troubleshooting, Continued

DOES NOT PRINT

PROBABLE CAUSE(S)	SOLUTION(S)
Printer in Energy Saver mode.	Push the Control Panel button.
Error message displays.	Follow message instructions.
Error Instrument is ON.	If the Ready Instrument is OFF , printer is out of toner. Replace the cartridge. If the Ready Instrument is flashing, load paper in the Main Tray.
Error Instrument is blinking.	<ul style="list-style-type: none"> • If the Ready Instrument is OFF, the printer is not working. Reboot the printer. • If the Ready Instrument is flashing, the printer is canceling a job or is initializing the non-volatile memory.
Both control panel Instruments are OFF .	<ul style="list-style-type: none"> • Turn off the printer, check the plug and outlet. Restart the printer.
The Ready Instrument is flashing.	<ul style="list-style-type: none"> • If the Ready Instrument is flashing, but the printer is not functioning, a previous print job could be in error. Delete any print jobs in the queue. • Force the printer to print by pushing the Control Panel button. • If the Ready Instrument is not flashing after sending a print job, check the USB cable connections, then reboot the printer.

MAKES UNUSUAL NOISES INSIDE

PROBABLE CAUSE(S)	SOLUTION(S)
Obstruction or debris inside the printer.	Turn off and unplug the printer, then remove the debris or obstruction. <ul style="list-style-type: none"> – <i>NEVER USE HAND TOOLS OR OTHER ITEMS TO PROBE INTO THE PRINTER.</i>

CONDENSATION INSIDE

PROBABLE CAUSE(S)	SOLUTION(S)
Printer has been sitting idle in a cold room.	<ul style="list-style-type: none"> • Wipe moisture out with cloth. Clean with alcohol and cotton balls. • Allow the printer to operate for several hours at room temperature.
Relative humidity of the room is too high.	<ul style="list-style-type: none"> • If possible, reduce the humidity within the room. • If not, move the printer location to where temperature and humidity are within the operating specifications.

APPENDIX I: FIELDBUS REFERENCE

A. Overview

The term **FIELDBUS** usually describes an all-digital two-way communications system that interconnects measurement and control equipment such as sensors, actuators and controllers.

- Fieldbus traces its beginnings in the automotive industry, where efforts to simplify and reduce wiring resulted in a multiplexed **CAN (Controller Area Network)** system of modules installed at various points of a vehicle.

WORKING EXAMPLE

Most cars have multiple controls on the door panel, such as power-window, power-mirror, power-lock and power-seat controls. A **Fieldbus Network** combines all the switch wires into a two wire communication **BUS**. Pressing a switch closes a relay that provides power to the window motor, sending a packet of data onto the communication bus to adjust the passenger-side mirror.

Noted below are the five (5) Fieldbus Interfaces types used with the FB2550 Instrument.

DEVICENET – A network system to interconnect control devices for data exchange.

- It uses a differential serial bus, called **Controller Area Network (CAN)**, as the backbone technology and defines an application layer to cover a range of device profiles.

CONTROLNET – An open Control Network in real-time, for high-throughput applications.

MODBUS-TCP – Serial network communications in a master/slave (request/response) type relationship using either ASCII or RTU (Remote Terminal Unit) modes.

- Non-powered two-wire (RS-485) network, with **up to 126 nodes**, transferring a maximum of 244 data bytes per node per cycle.

PROFIBUS – Protocol use primarily in Europe which utilizes a non-powered two-wire (RS-485) Network.

ETHERNET/IP – An **Industrial Application Layer Protocol** used for communication between industrial control systems and their components.

- Not to be confused with the simple combination of EtherNet and the Internet Protocol, but instead, the “IP” in EtherNet/IP stands for “**Industrial Protocol**”.
- *Such components include* **Programmable Automation Controller, Logic Controller, or an I/O System.**

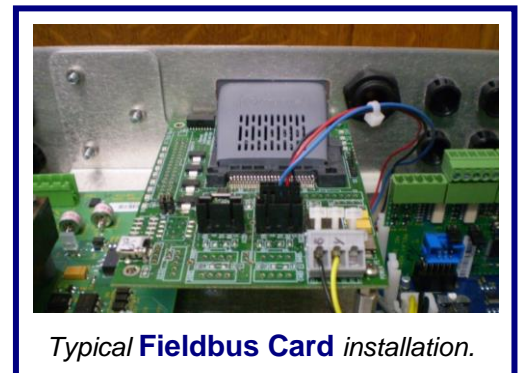

*Typical **Fieldbus Card** installation.*

NOTE: For complete procedures, see **Section 10.4. Installing the Fieldbus Interface Kit (30922 thru 30925).**

B. DeviceNet (30923)

DEVICENET is a low-cost communications link that connects industrial devices to a network, eliminating expensive hardwiring.

- It is based on a broadcast-oriented, communications protocol the **CAN**.
- The **CAN Protocol** was originally developed by BOSCH for the European automotive market for replacing expensive wire harnesses with low-cost network cable.
- The **CAN Protocol** has fast response and high reliability for applications like anti-lock brakes and air bags.

DEVICENET also provides power to the network. This allows devices with limited power requirements to be powered directly from the network.

- This reduces connection points and physical size.
- The maximum network size is **up to 64 Nodes**, with message data packets **up to 8 bytes**.

WIRE	SIGNAL	DESCRIPTION
1	V	Negative bus supply voltage
2	CAN_L	CAN low bus line
3	SHIELD	Cable shield
4	CAN_H	CAN high bus line
5	V+	Positive bus supply voltage



B. DeviceNet (30923), Continued

NETWORK STATUS LED

STATE	INDICATION
OFF	Not online/ No power
GREEN	Online, one or more connection established
FLASHING GREEN (1 Hz)	Online, no corrections established
Red	Critical link failure
Flashing Red (1 Hz)	One or more connections timed out
Alternating Red/Green	Self-test

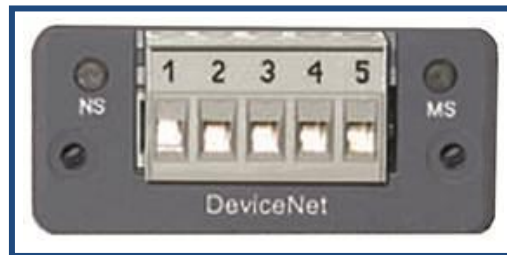

NS = **Operation Mode** LED
MS = **Mode Status** LED
Connection = DeviceNet Connector

MODULE STATUS LED

STATE	INDICATION
OFF	No power
GREEN	Operating in normal condition
FLASHING GREEN (1 Hz)	Missing/Incomplete configuration/ Device needs commissioning
Red	Unrecoverable fault(s)
Flashing Red (1 Hz)	Recoverable fault(s)
Alternating Red/Green	Self-test

C. ControlNet (30924)

CONTROLNET (30924) is an open ControlNetwork running in “real-time”, for high-throughput applications.

- It uses a **Control and Information Protocol (CIP)**, combining the functionality of an I/O Network and a Peer-to-Peer Network.
- **CONTROLNET** is based on the **Producer/Consumer Model**, permitting all nodes on the network to simultaneously access the same data from a single source.
- Maximum of **99 nodes**, with no minimum distance between nodes
- The ControlNet card uses BNC connectors.



SPECIAL NOTES

For **signal redundancy**, both connectors should be used.

Network Status LED A and **Module Status LED** correspond to **LED 1** and **LED 2** in the instance attributes of the **Anybus Object**.

- They are available in the application interface, but the LED placement on the front does not conform to the standard **Anybus CompactCom** placement of **LED 1** and **LED 2**.

C. ControlNet (30924), Continued

NETWORK STATUS

LED	STATE	INDICATION
A and B	OFF	Not online / No power
	Flashing Red (1 Hz)	Incorrect node configuration, duplicate MAC ID etc.
	Alternating Red/Green	Self test of bus controller
	Red	Fatal event or faulty unit
A or B	OFF	Channel is disabled
	Alternating Red/Green	Invalid link configuration
	Flashing Green (1 Hz)	Temporary errors (node self-corrects) or node is not configured to go online.
	Green	Normal operation
	Flashing Red (1 Hz)	Media fault or no other nodes on the Network

MODULE STATUS

STATE	INDICATION
OFF	No power
GREEN	Operating in normal condition, controlled by a Scanner in RUN state .
FLASHING GREEN (1 Hz)	The module has not been configured or the Scanner is in the Idle state .
Red	Unrecoverable fault(s), EXCEPTION,
Flashing Red (1 Hz)	Media fault or no other nodes on the Network

NO.	DESCRIPTION
1	Network Status LED A
2	Module Status LED
3	Network Status LED B
4	ControlNet Connector A
5	ControlNet Connector B

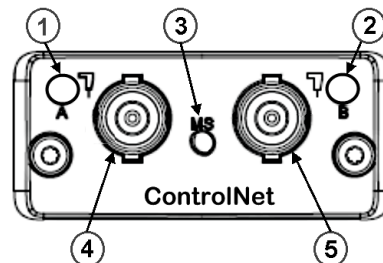

D. Modbus RTU (30925)

MODBUS (30925) PROTOCOL was originally developed in 1978 to exchange information between devices on the factory floor.

- It developed into the standard for exchanging data and communication **MODULE STATUS** information between PLC systems.
 - Modbus-TCP devices communicate over a **Serial Network** in a **master/slave** (request/response) type relationship.
 - Uses either the **ASCII** (American Standard Code for Information Interchange) **mode** or the **RTU** (Remote Terminal Unit) **mode**.
- In the **ASCII MODE**, two eight-bit bytes of data are sent as two ASCII characters.
 - The primary advantage of ASCII mode is the flexibility of the timing sequence.
 - Up to a one second interval can occur between character transmissions without causing communication errors.
- In the **RTU MODE**, data is sent as two four-bit, hexadecimal characters, providing for higher throughput than in ASCII mode for the same baud rate.
 - Modbus Plus communicates using a single twisted pair of wires in one shielded cable (**#18AWG**).
 - Modbus Plus **does NOT** provide power on the network.
- Maximum of up to **32 Nodes**, and up to **64** with a Repeater.

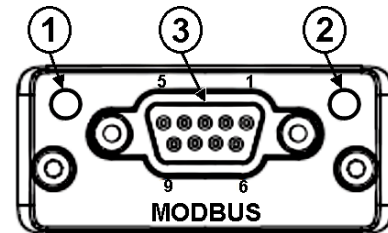

NO.	DESCRIPTION
1	Communication LED
2	Device Status LED
3	Modbus Interface

COMMUNICATION LED

LED STATE	DESCRIPTION
OFF	No power - <i>OR</i> - no traffic
YELLOW	Frame reception or transmission
RED	A fatal error has occurred

D. Modbus RTU (30925), Continued

DEVICE STATUS LED

LED STATE	INDICATION
OFF	Initializine – OR – no power
GREEN	Module initialized, no error
RED	Internal error – OR –major unrecoverable fault
RED, SINGLE FLASH	Communication fault or configuration error Case 1: Invalid setttings in Network Configuration error Case 2: Settings in Network Configuration Object has been changed during runtime (i.e. the settings do not match the currently used configuration).
RED, DOUBLE FLASH	Application diagnostics available.

MODBUS-TCP INTERFACE

PIN	DIRECTION	SIGNAL	COMMENT
Housing	—	PE	Protective Earth
1	—	GND	Bus polarization, ground (isolated)
2	Output ³	5V	Bus polarizatio power +5V DC (isolated)
3	Input	PMC	Connect to pin #2 for RS-232 operation
4			
5	Bidirectional	B-LINE	RS-485 B-Line
6			
7	Input	RX	RS-232 Data Receive
8	Output	TX	RS-232 Data Transmit
9	Bidirectional	A-Line	RS-485 A-Line

E. Modbus-TCP Interface Kit (32760)

Modbus-TCP is an open Master/Slave application protocol that can be used on top of Ethernet-TCP/IP. Modbus reads in 16 bit register sizes == 1 word == (2) bytes.

Test Software: recommended from industry customers

Simply Modbus TCP – free to evaluate Modscan32 - evaluation

Software Recomedations:

IPConfig – Developed by HMS Industries, free to use application that scans a network for ModbusTCP devices, and allows IP assignment.

<https://www.anybus.com/support/file-doc-downloads/compactcom-30-series-specific/?ordercode=AB6223>

Sample Reference to Input Data:

Function Code	Behavior	Absolute Address	Modicon 5 digital Address
3	Read Holding Register	0-79 , 256-335	40001-40080
4	Read Input Registers	0-79	30001-30080
Example Gross WT.			
3	Read Input Registers	5,6	

Connection Style:

RJ45 – Standard Ethernet Cat5 (supply sketch of back of module)

Duplexing is 10/100 Mbits/ full/half, and can be configured from the web interface.

F. ProfiBus-DP (30922)

PROFIBUS-DP utilizes a **non-powered two-wire (RS-485) Network**.

- A PROFIBUS-DP Network may have **up to 126 nodes**, transferring a maximum of **244 bytes data per node/ per cycle**.
- Baud (Communication) Rates are selectable, and overall end-to-end network distance varies with speed.
- The maximum standard Baud Rate is **12Mbps**, with a maximum distance of **100M (328ft)**, and **1200M (3936 ft)** at **93.75Kbps** without repeaters.
- **PROFIBUS-DP** connects to a wide variety of field devices including the following:
 - *Discrete and analog I/O Drives.*
 - *Robots.*
 - *HMI/MMI products.*
 - *Pneumatic valves.*
 - *Barcode readers.*
 - *Weigh scales.*
 - *Transducers.*
 - *Flow measuring equipment.*

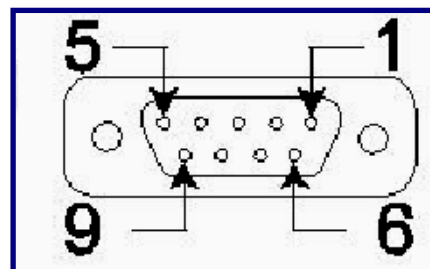

F. ProfiBus-DP (30922), Continued

PIN	SIGNAL	DESCRIPTION
3	B-Line	Positive RxD/TxD, Rs485 level
4	RTS	Request to Send
5	GND	Ground (Isolated)
6	+5 Bus Output	+5V termination power (Isolated, short circuit protected)
8	A-Line	Negative RxD/TxD, RS485 level

OPERATION MODE LED

LED STATE	DESCRIPTION	COMMENTS
OFF	Not online or No power	
Green	Online/ Data Exchange	
Flashing Green	Online, clear	
Flashing Red (1 flash)	Parameterization error	See Parameterization Data Handling
Flashing Red (2 flashes)	PROFIBUS-DP configuration error	See Configuration Data Handling

MODULAR STATUS LED

LED STATE	DESCRIPTION	COMMENTS
OFF	No power - <i>OR</i> – not initialized	Module state = “SETUP” OR NW-INIT
Green	Initialized	Module has left the NW_INIT state
Flashing Green	Initialized, diagnostic events(s) present	Extended diagnostic bit is set
Red	Exception error	Module state = EXCEPTION

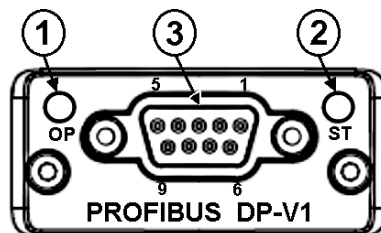

NO.	DESCRIPTION
1	Communication LED
2	Device Status LED
3	Modbus Interface

NOTE: Additional information and **EDS files** are available at the following website.
<https://www.anybus.com/support/file-doc-downloads/compactcom-30-series-specific/?ordercode=AB6200>

G. EtherNet/IP (31974)

The **ETHERNET/IP MODULE** utilizes the Industrial Protocol.

- The data is transmitted continuously from this module.
- Utility IPConfig – Developed by HMS Industries can scan a network for Ethernet IP devices, and allows IP assignment.
- EDS (Electronic Data Sheet file (Vendor specific data is accessible and recommended
- A custom EDS (Electronic Data Sheet) file is available from our website, uploading this file into PLC software can then help target correct memory addressing for scale data.



Use the following download to change the IP, Sub Net and Gateway addresses of an Ethernet/IP Module.

<https://www.anybus.com/docs/librariesprovider7/default-document-library/software/hms-IPConfig.zip?sfvrsn=20>

Use the following download to load into PLC software for configuring the Ethernet/IP module.

http://www.fairbanks.com/software/FB2550_090513.zip

Shown below is the **NETWORK Status LED Chart**.

STATE	DESCRIPTION
Off	No power or offline.
GREEN	Online, one or more connections established.
FLASHING	Online, no connections established.
RED	Duplicate IP address, FATAL error
FLASHING RED	One or more connections timed out.

Shown below is the **MODULE** Status LED Chart.

STATE	DESCRIPTION
Off	No power.
GREEN	Controlled by a scanner in RUN state.
FLASHING	Not configured, or scanner in idle state.
RED	Major fault, FATAL error.
FLASHING RED	Recoverable fault(s).

Shown below is the **Link / Activity** LED Chart.

STATE	DESCRIPTION
Off	No link, no activity.
GREEN	Link established.
FLICKERING GREEN	Activity.

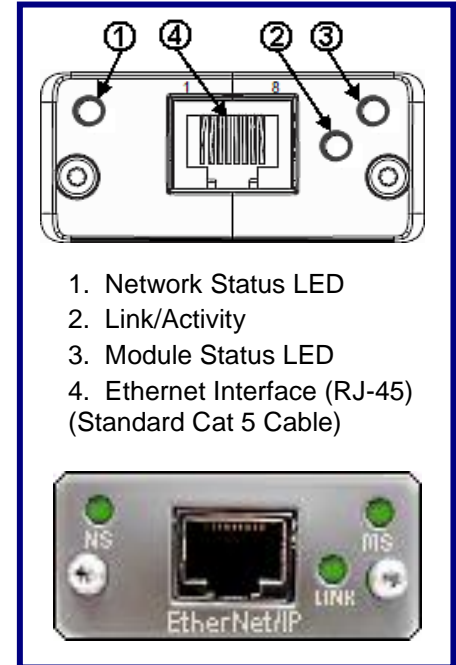

H. Fieldbus Protocols and Formats

Transmission Methods

Communication protocols are similar to conversations; there are several different languages and methods used.

- **PROFIBUS-DP, MODBUS-TCP, INTERBUS-S,** and **ETHERNET/IP** use a method called "**source-destination**" communications. The message packets have destination information in them, and the Fieldbus passes a token from node to node in a timed fashion.
- **DEVICENET, CONTROLNET,** and **CAN** use a **broadcast, producer-consumer model for communications.** Messages are broadcast to all nodes, and each node only "hears" messages intended for it.

Communication Format

Another major difference among Fieldbuses is the format of the communications themselves.

- **DEVICENET** and **CAN** messages are eight bytes long.
- **PROFIBUS-DP** is "word-oriented", and can have up to **256-byte** "stack" per message.

COSTS vs. SPEED

- **PROFIBUS-DP** and **CONTROLNET** are very fast networks – **12 megabits per second** and **500 Mb/s**, respectively. They are much more expensive to operate.
- **DEVICENET** is less expensive.

Handling Network Traffic

FIELDBUSES also handle network traffic in different ways.

- **DEVICENET** and **CAN** use "**non-destructive bitwise arbitration.**" When two messages collide, the higher priority message goes first. If the two are equal priority, there is a mechanism within DeviceNet (as well as CAN) that decides which one should go first.
- When a collision occurs in **ETHERNET**, all devices "back off" and re-send their messages, which results in slower transmissions.

I. DT7000 Gateway

The **DT7000 Communication I/O Gateway** is a module that provides access between Industrial Networks and the serial device(s).

- The DT7000 utilizes one of the available Anybus Compact COM Modules for the desired Fieldbus.
- The Fieldbus Interface(s) support a bi-directional communication capability for the Instrument.
- The FB2550 Interface supports a variety of **Industrial Protocols.**

The following Fieldbus Networks are supported by the DT7000.

- | | | |
|---------------|---------------|--------------|
| • Profibus-DP | • EtherNet/IP | • ControlNet |
| • DeviceNet | • MODBUS-TCP | |



MODULE LAYOUT

The image below shows the module layout.

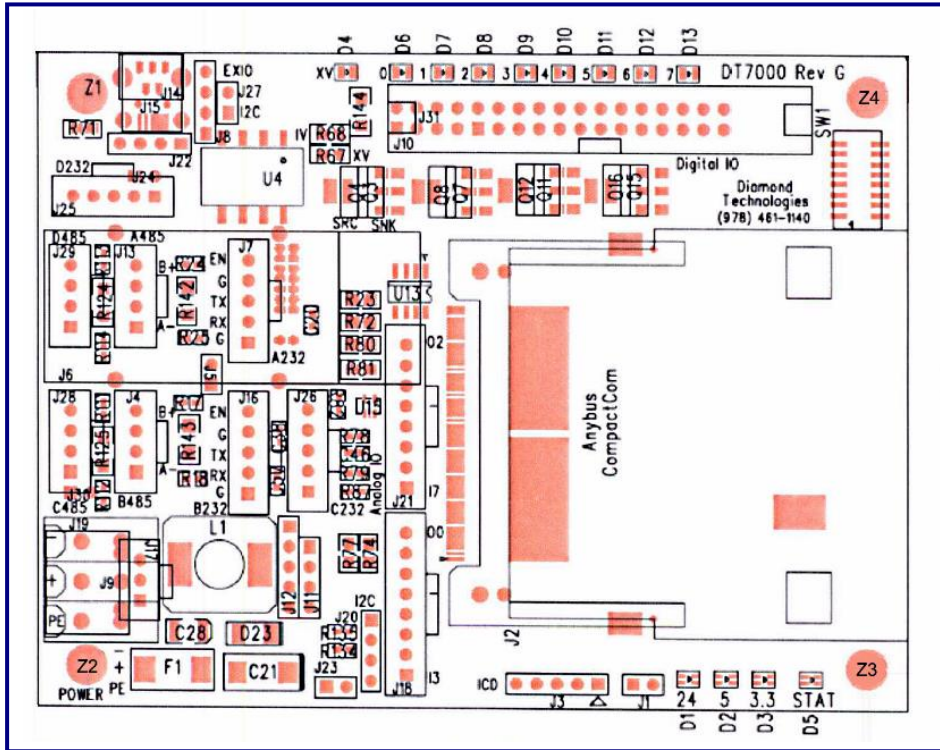

INPUT POWER

The DT7000 requires **Input Power of 9 to 40 VDC (24VDC normally)** at the **Terminal Block Connector (J-19)**.

See the cart below for **Input Power connections**.

J19 PIN	SIGNAL
1	PE
2	+V
3	-V

DT7000 SERIAL PORT CONNECTIONS

The DT7000 has four (4) serial ports.

Only **Port B J16** is used.

See the two following tables for connecting **serial devices to the DT7000**.

RS232

PORT B (J16)	SIGNAL
1	GND
2	RX
3	TX
4	GND
5	ENB

If the **ENB Signal** on the RS232 connector is tied to the **Ground**, the **RS232** is *active*, and the RS485 is disabled. If not, the **RS485** is *active*, and the RS232 is disabled.

- Connect pins **four and five (4 & 5)** on the **RS232 (J12, J4)** to enable RS232.

FIELDBUS CONNECTION

The Fieldbus connects to the **Anybus-CompactCOM Module**.

- This connector is Fieldbus-specific.
- There are also LEDs on this module.

MODULE INDICATORS

Listed below are the four power LEDs on the module.

REF	GREEN	RED
D1	+24 POWER OK	REVERSE INPUT POWER
D2	+5V POWRE OK	RESETTLE FUSE TRIPPED
D3	+3.3V POWER OK	--
D4	I/O POWER OK	REVERSE I/O POWER

D1 indicates 24V power is applied to the module. D2 and D3 indicate the internal voltages are being generated. All (3) LEDs will be on green when the module is operating properly. D4 indicates the I/O power is applied to the module and will be illuminated green when I/O power is present.

There is a red/green dual color status LED (D5) on the module. On power up the LED flashes alternately red and green to indicate the module is starting up. Once the module is initialized, the status LED has the following meaning.

D5- STATE	INDICATION
Flashing RED	Not communicating to serial device
Flashing GREEN	Communicating to the serial device
Flashing mostly OFF (RED or GREEN)	Not communicating on Fieldbus
Flashing Mostly on (RED or GREEN)	Communicating on Fieldbus
Solid RED	Module failure

MODULE DIP SWITCHES

There is an 8 position DIP switch on the module. The 8 switches are used to set the network address on the fieldbus. These switches set an address in binary. A switch in the **UP (OFF)** position corresponds to a **1-bit**.

Example: Address 05.

ADDRESS	SWITCH POSITION							
	1	2	3	4	5	6	7	8
05	Up	Dn	Up	Dn	Dn	Dn	Dn	Dn

If the switches are all **DOWN (0 VALUE)**, then the module will read the Fieldbus address from the EEPROM on the CompactCom module. This should also be used if the fieldbus address will be set over the network by a network configuration tool.

MODULE DIP SWITCHES, CONTINUED

The switches can be used to reset all configurable parameters in the DDOOO to factory default values, and to erase the user application. If the switches are all up (255 value) on power up, the status LED (D5) will flash red for 5 seconds, and on the diagnostic port the message **“Change Switches to Reset to Factory Defaults”** displays. Changing any switch value at this time will reset the module to a factory default state. If the switches remain unchanged, the module will start with a switch value of 255.

The meaning of the address and the valid range is fieldbus specific. Refer to the specific fieldbus supplement for the exact meaning of the dip switch settings.

SERIAL COMMUNICATIONS SETTINGS

The communications settings for the serial port is configured for the application. The module is configured by default with the following settings.

PORT	BAUD	DATA BITS	PARITY	FUNCTION
Port B, J16	115200	8	None	Generic setting

Many of the serial settings can be configured through the diagnostic port. These include enabling or disabling the Generic Serial driver on each port, defining the buffers sizes for the Generic Serial driver, and setting the communication parameters, including BAUD rate and parity. Some settings can only be configured through a user application, including enabling MODBUS master functionality or custom serial protocols on a serial port.

HARDWARE SPECIFICATIONS

Power	9-40 VDC (24 VDC Nominal)
Power Consumption	300 mA typical 800 mA max (@24 VDC)
Interface connections	Fieldbus as selected, serial channel
LEDs/Instruments	Power, Network connection
Operating Temperature	0 to 70 C
Storage Temperature	-40 to 85 C
Operating humidity	90% non-condensing
Enclosure rating	None
Mounting options	Thru holes
Others	RoHS
Physical Dimensions	4.24 inches x 3.20 inches
Approval	CE

SOFTWARE SPECIFICATIONS

Output Data Format to Gateway

The **Gateway** takes a Serial String and remap the data to the format needed for the Fieldbus type installed per the register.

- The following is the definition of the **Serial String** for one (1) scale.
 - The Scale ID is extracted from **Status Word 0**.
 - The data is placed in the appropriate Fieldbus Registers based on this scale ID.
 - **Status Word Data** is sent as binary values **MSB** first over the Serial Channel.
 - Weight data is sent as six (6) characters representing a 6-digit decimal value (000000 – 999999).
 - This decimal value represents the weight multiplied by the scale factor, listed in **Command/Status Word 1 bits 0-2**.
 - The serial string is a fixed length of fifty-seven (57) bytes.

STX character	1 byte, (02h)	
Status word 0	2 bytes,	(includes scale ID)
Status word 1	2 bytes,	
Status word 2	2 bytes,	
Unassigned data	6 characters	(default '000000')
Gross Weight	6 characters	(example '002340')
Tare Weight	6 characters,	
Net Weight	6 characters,	
Setpoint 1	6 characters,	
Setpoint 2	6 characters,	
Flow Rate	6 characters,	
Unassigned data	6 characters,	
CRC	1 byte,	
ETX character	1 byte	(03h)

SOFTWARE SPECIFICATIONS, CONTINUED

Note Weight Values sent over the Serial Channel will be represented in the Fieldbus registers based on the settings of **bits 14** and **15** in **STATUS WORD 0**.

- If the data is set to be a 16 bit or 32 bit integer, then the register value will contain the integer value and the host must multiply this by the scale factor to get the actual weight.
- If it is set to be a 16 bit integer, and the integer value is greater then **65535**, a value of **0** is placed in the register.
- If the data is set to be **FLOATING POINT**, then the gateway will multiply the integer value received by the scale factor, and place the resulting 32 bit floating point value in the register.
 - *In this case the host does not use the scale factor to interpret the value.*

INPUT DATA FORMAT FROM GATEWAY

The Gateway will send a string to the Serial Port reflecting data from the Fieldbus.

The following is the definition of the serial string for one (1) scale.

- The scale ID in the Fieldbus register for Command word 0 for a scale must be set to the correct value (1-4) before data for that scale will be sent over the serial channel.
- If the scale ID is set to the correct value, any time any data for this scale changes the data will be sent out the serial channel.
- Command word data is sent as binary values MSB first over the serial channel.
- Weight data is sent as six (6) characters representing a **six (6) digit decimal value (000000 – 999999)**.
- This decimal value represents the weight multiplied by the scale factor listed in **command/status word 1 bits 0-2**.
- The serial string is a fixed length of **105 bytes**.

INPUT DATA FORMAT FROM GATEWAY, CONTINUED

STX character	1 byte,	(02h)
Command word 0	2 bytes,	(includes scale ID)
Command word 1	2 bytes,	
Command word 2	2 bytes,	
Setpoint 1 weight	6 characters,	
Setpoint 2 weight	6 characters,	
Tare Weight	6 characters,	
Display Message 1	26 characters,	
Display Message 2	26 characters,	
Display Message 3	26 characters,	
CRC	1 byte,	
ETX character	1 byte	(03h)

Note Weight Values sent over the serial channel will represent data in the Fieldbus registers based on the settings of **bits 14** and **15** in **STATUS WORD 0**.

- If the data is set to be a 16 bit or 32 bit integer, then the integer value in the register will be sent over the serial channel.
- If it is set to be 16 bit, the high order word will be ignored.
- If the data is set to be floating point, then the floating point value will be multiplied by the scale factor and the integer portion of this resulting value will be sent over the serial channel.
- In all cases if the resulting integer is greater than **999999**, a value of **000000** will be sent over the Serial Channel.
- In all cases the scale must multiply the integer by the scale factor to determine the actual weight.

DISPLAY MESSAGES

A change in the Display Message Strings will not cause a serial string to be sent. The **Display Message Strings** will be sent when any data for a scale is changed (provided the Scale ID is set to the correct value for that scale).

Typically, this will happen when command word 2 bit 1 is set indicating the display messages are to be displayed. There is a maximum of 26 characters per line for the Display Message Strings.

Serial data is transferred according to the RS232 specification between the gateway and the FB2550. The communications parameters are listed below.

Baud	115,200
Data Bits	8
Parity	None
Stop Bits	1

J. Standard DT7000 Fieldbus Configuration

The **DT7000 Fieldbus Module** is a specialized component, so it requires different parameters than the standard Expansion Card default setups.

Follow these steps to program the DT7000 for Fieldbus Modules.

6. While in the **WEIGH SCREEN**, press the **MENU** button.
7. Select **LOGIN**.
8. Enter the **Write Customer or Service Password**.
9. Press the **LOGIN** button.
10. Open the **CONFIGURATION MENU**.
11. Press **PAGE FORWARD** once.
12. Open the **CONFIGURE OUTPUTS** option.
13. Select **CONFIGURE COM4**.
14. Select **LOAD**.
15. Select **DT7000 ANYBUS**.

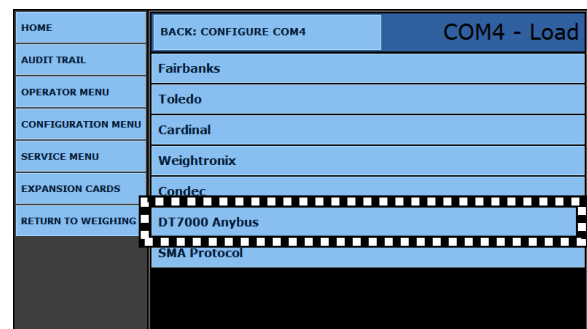
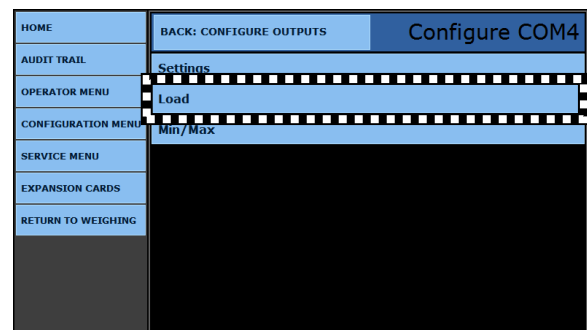
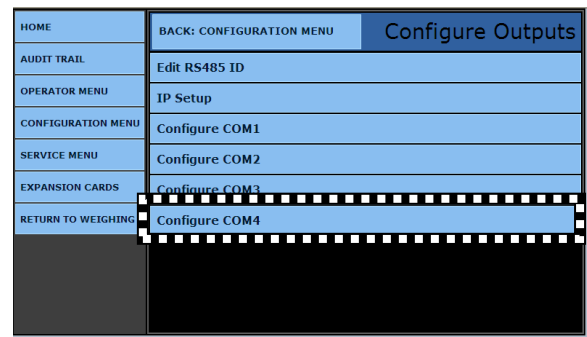
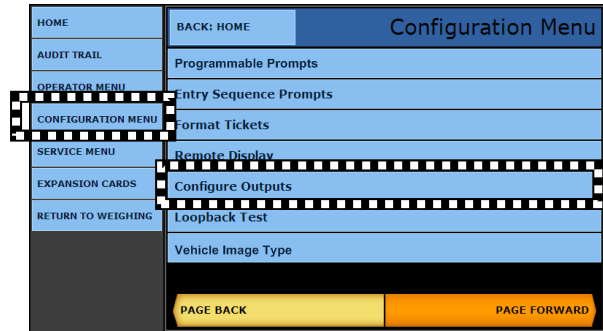

J. Standard DT7000 Fieldbus Configuration, Continued

NOTE: The EtherNet/IP Module utilizes the DT7000 Interface. For complete programming details, see **Appendix I: Fieldbus Interface Reference**.

For the complete data string programming details, see **Appendix II: Data Output**.

16. Answer **YES** to making the DT7000 Fieldbus the default setup.

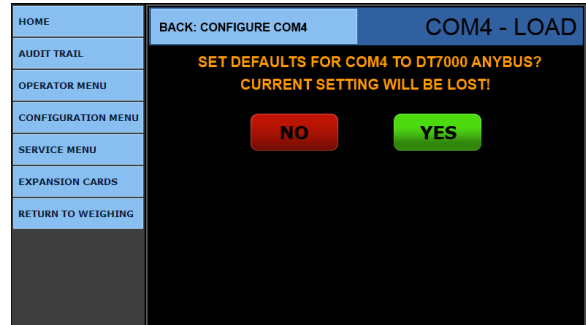

17. Select **SETTINGS**.

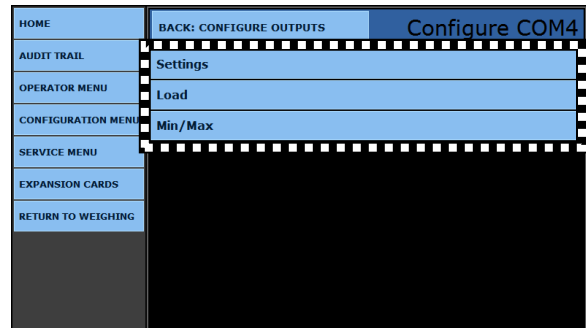

18. Set these standard parameters.

BAUD RATE	115200
PARITY	NONE
DATA BITS	8
STOP BITS	1
CHECKSUM	SELECTED

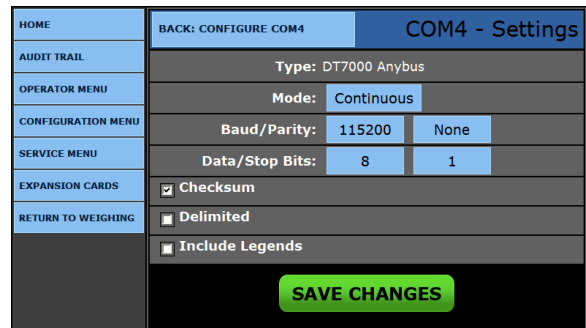

19. Press the **SAVE CHANGES** button, returning to the **CONFIGURE COM4** menu.

20. Select **MIN/MAX**.

21. Enter the **Minimum Weight** and the **Maximum Weight** amounts.

- These amounts determine the two “soft” setpoints that change one of the status bytes in the **Fieldbus Output String**.
- When exceeded, a byte is set.





– See **APPENDIX I: STATUS/ COMMAND WORD 2.**

22. Press the **SAVE CHANGES** button.

K. Fieldbus Data Representation

The following information shows the representation of data on all Fieldbuses. Each Fieldbus has input data (from the gateway/scales to the Fieldbus), and output data (from the Fieldbus to the gateway/scales).

ALL FIELDBUS TYPES OUTPUT MEMORY MAP

START ADDRESS	HEX	DECIMAL	SIZE
Scale 1	0	0	10 Words
Scale 2	14	20	10 Words
Scale 3	28	40	10 Words
Scale 4	3C	60	10 Words
Scale Message Line 1	50	80	26 bytes
Scale Message Line 2	6A	106	26 bytes
Scale Message Line 3	84 1	32	26 bytes
Unassigned	9E	158	2 bytes
Total:			160 bytes

START ADDRESS	HEX	DECIMAL	SIZE
Scale 1	0	0	20 Words
Scale 2	28	40	20 Words
Scale 3	50	80	20 Words
Scale 4	78	120	20 Words
Total:			160 bytes

**OUTPUT DATA (WORD BYTE REGISTER USAGE)**

WORD	BYTE	REGISTER USAGE	SIZE(BYTES)	SCALE
0	0 - 1	Command Word 0	2	Scale 1
1	2 - 3	Command Word 1	2	
2	4 - 5	Command Word 2	2	
3 - 4	6 - 9	Setpoint 1	4	
5 - 6	10 - 13	Setpoint 2	4	
7 - 8	14 - 17	Tare Weight	4	
9	18 - 19	Unassigned	2	
10	20 - 21	Command Word 0	2	Scale 2
11	22 - 23	Command Word 1	2	
12	24 - 25	Command Word 2	2	
13 - 14	26 - 29	Setpoint 1	4	
15 - 16	30 - 33	Setpoint 2	4	
17 - 18	34 - 37	Tare Weight	4	
19	38 - 39	Unassigned	2	
20	40 - 41	Command Word 0	2	Scale 3
21	42 - 43	Command Word 1	2	
22	44 - 45	Command Word 2	2	
23 - 24	46 - 49	Setpoint 1	4	
25 - 26	50 - 53	Setpoint 2	4	
27 - 28	54 - 57	Tare Weight	4	
29	58 - 59	Unassigned	2	

**OUTPUT DATA (WORD BYTE REGISTER USAGE), CONTINUED**

WORD	BYTE	REGISTER USAGE	SIZE(BYTES)	SCALE
30	60 - 61	Command Word 0	2	Scale 4
31	62 - 63	Command Word 1	2	
32	64 - 65	Command Word 2	2	
33 - 34	66 - 69	Setpoint 1	4	
35 - 36	70 - 73	Setpoint 2	4	
37 - 38	74 - 77	Tare Weight	4	
39	78 - 79	Unassigned	2	
	80 - 105	Display Message Line 1	26	All Scales
	106 - 131	Display Message Line 2	26	
	132 - 157	Display Message Line 3	26	

INPUT DATA (WORD BYTE REGISTER USAGE)

WORD	BYTE	REGISTER USAGE	SIZE(BYTES)	SCALE
0	0 - 1	Status Word 0	2	Scale 1
1	2 - 3	Status Word 1	2	
2	4 - 5	Status Word 2	2	
3 - 4	6 - 9	Unassigned	4	
5 - 6	10 - 13	Gross Weight	4	
7 - 8	14 - 17	Tare Weight	4	
9 - 10	18 - 21	Net Weight	4	
11 - 12	22 - 25	Setpoint 1	4	
13 - 14	26 - 29	Setpoint 2	4	
15 - 16	30 - 33	Flow Rate (weight /second)	4	
17 - 19	34 - 39	Unassigned	6	



INPUT DATA (WORD BYTE REGISTER USAGE), CONTINUED

WORD	BYTE	REGISTER USAGE	SIZE(BYTES)	SCALE
20	40 - 41	Status Word 0	2	Scale 2
21	42 - 43	Status Word 1	2	
22	44 - 45	Status Word 2	2	
23 - 24	46 - 49	Unassigned	4	
25 - 26	50 - 53	Gross Weight	4	
27 - 28	54 - 57	Tare Weight	4	
29 - 30	58 - 61	Net Weight	4	
31 - 32	62 - 65	Setpoint 1	4	
33 - 34	66 - 69	Setpoint 2	4	
35 - 36	70 - 73	Flow Rate (weight /second)	4	
37 - 39	74 - 79	Unassigned	6	
40	80 - 81	Status Word 0	2	Scale 3
41	82 - 83	Status Word 1	2	
42	84 - 85	Status Word 2	2	
43 - 44	86 - 89	Unassigned	4	
45 - 46	90 - 93	Gross Weight	4	
47 - 48	94 - 97	Tare Weight	4	
49 - 50	98 - 101	Net Weight	4	
51 - 52	102 - 105	Setpoint 1	4	
53 - 54	106 - 109	Setpoint 2	4	
55 - 56	110 - 113	Flow Rate (weight /second)	4	
57 - 59	114 - 119	Unassigned	6	

**INPUT DATA (WORD BYTE REGISTER USAGE), CONTINUED**

WORD	BYTE	REGISTER USAGE	SIZE(BYTES)	SCALE
60	120 - 121	Status Word 0	2	Scale 4
61	122 - 123	Status Word 1	2	
62	124 - 125	Status Word 2	2	
63 - 64	126 - 129	Unassigned	4	
65 - 66	130 - 133	Gross Weight	4	
67 - 68	134 - 137	Tare Weight	4	
69 - 70	138 - 141	Net Weight	4	
71 - 72	142 - 145	Setpoint 1	4	
73 - 74	146 - 149	Setpoint 2	4	
75 - 76	150 - 153	Flow Rate (weight /second)	4	
77 - 79	154 - 159	Unassigned	6	



STATUS/COMMAND WORD BIT USAGE

Status / Command Word 0

bit	Usage
0	Scale ID bits 0, 1, 2
1	Scale 1 = 001, Scale 2 = 010, Scale 3 = 011, Scale 4 = 100
2	
3	motion
4	over capacity gross weight = scale capacity
5	within 2% capacity
6	Enable Tare
7	Disable Tare
8	lb units
9	kg units
10	ton units
11	tonne units
12	
13	
14	Weight conversion, text to numeric (bits 14 and 15)
15	01 = 32 bit floating point
	10 = 32 bit integer
	11 = 16 bit integer



STATUS/COMMAND WORD BIT USAGE

Status / Command Word 1

bit	Usage
0	Decimal Point Location bits 0, 1, 2
1	000 * 1.0; 001 * 0.1; 010 * 0.01; 011 * 0.001; 100 * 0.0001
2	
3	Load Tare Command
4	Auto Tare Command
5	Load Setpoint 1
6	Load Setpoint 2
7	Zero Scale Command
8	Load Cell Status bits 8, 9, 10, 11, 12
9	All Good = 0
10	Defective Cell = Cell Number Binary
11	
12	
13	
14	Print Command
15	Beep

Status / Command Word 2

bit	Usage
0	Display Message Command / Operator Acknowledge
1	Scale weight at or above Maximum weight
2	Scale weight at or below Minimum weight
3 -15	Unused



STATUS/COMMAND WORD BIT USAGE, CONTINUED

SCALE ID WORD 0 BITS 0,1,2

Command: Changes Instrument display to applicable scale.
Status: Value is the scale id if the scale is selected, from instrument keyboard or Fieldbus, else the value is zero.

MOTION WORD 0 BIT 3

Command: Not applicable.
Status: Indicates that the scale senses motion.

OVER CAPACITY WORD 0 BIT 4

Command: Not applicable.
Status: Indicates that the scale is at 105% of capacity. If this condition is true the gross weight is sent to the Fieldbus as the scale capacity.

WITHIN 2% CAPACITY WORD 0 BIT 5

Command: Not applicable.
Status: Scale is within a range of +/- 2% of capacity and zero.

ENABLE TARE WORD 0 BIT 6

Command: Enable keyboard tare or auto tare weight.
Status: Tare weight enabled.

DISABLE TARE WORD 0 BIT 7

Command: Disable keyboard tare and auto tare weight.
Status: Tare weight disabled.

LB WEIGHT UNITS WORD 0 BIT 8

Command: Switch scale to lb units.
Status: Scale is indicating in lb units.



STATUS/COMMAND WORD BIT USAGE, CONTINUED

KG WEIGHT UNITS WORD 0 BIT 9

Command: Switch scale to kg units.

Status: Scale is indicating in kg units.

TON WEIGHT UNITS WORD 0 BIT 10

Command: Switch scale to ton units.

Status: Scale is indicating in ton units.

TONNE WEIGHT UNITS WORD 0 BIT 11

Command: Switch scale to tonne units.

Status: Scale is indicating in tonne units.

DECIMAL LOCATION WORD 1 BITS 0,1,2

Command: Used in integer to float weight conversions.

Status: Indicates location of decimal point in weight data.

LOAD TARE WORD 1 BIT 3

Command: Load tare from tare memory address.

Status: Switches to 1 after command is executed and returns to 0 when command is cleared.

AUTO TARE WORD 1 BIT 4

Command: Take current scale gross weight as tare value.

Status: Switches to 1 after command is executed and returns to 0 when command is cleared.

LOAD SETPOINT 1 WORD 1 BIT 5

Command: Load setpoint 1 for this scale.

Status: Switches to 1 when command is executed returns to zero when command is cleared.



STATUS/COMMAND WORD BIT USAGE, CONTINUED

LOAD SETPOINT 2 WORD 1 BIT 6

Command: Load setpoint 2 for this scale.

Status: Switches to 1 when command is executed returns to zero when command is cleared.

LOAD CELL STATUS WORD 1 BITS 8,9,10,11,12

Command: Not applicable.

Status: All cells are when the value is zero, else data indicates the number of the failing or failed cell.

PRINT COMMAND: WORD 1 BIT 14

Command: Print scale ticket

Status: Switches to 1 when the command is recognized and resets after the print cycle is complete and the command bit is reset.

BEEP WORD 1 BIT 15

Command: Sound Instrument audible alarm.

Status: Switches to 1 when command is executed, resets to 0 after the command bit is reset.

DISPLAY MESSAGE WORD 2 BIT 0

Command: Display message on Instrument display. Message loaded from display memory 1 to 3 lines.

Status: Switches to 1 when the command is received and the message is displayed.

When scale operator operates any key, the message and bit are cleared.

SCALE ABOVE MAXIMUM WEIGHT WORD 2 BIT 1

Command: Not applicable.

Status: Bit is set when scale weight is at or above the programmed value.

SCALE BELOW MINIMUM WEIGHT WORD 2 BIT 2

Command: Not applicable.

Status: Bit is set when scale weight is at or below programmed value.

APPENDIX II: DATA OUTPUT

A. Remote Display Output

DATA FORMAT

<STX><A><0><SP/-><XXXXXX><ETX>

NOTES:

1. Characters denoted by X are characters 0-9.
 2. Leading zeroes are suppressed.
 3. Polarity indication for a positive value is a space (SP).
 - Negative values are not transmitted.
 4. Identifier code <4><0> = Gross weight.
 - Transmission is Gross Only.
 5. Transmission for the DEMAND Mode occurs when a carriage return (CR) HEX 0D is received.
 6. See APPENDIX V for more ID Codes.
-

B. Configure Output

The Continuous Computer Output is an uninitiated, unrequested output that gets transmitted at a fixed time interval.

FAIRBANKS/TOLEDO DATA FORMAT

<STX><A><C><GGGGGG><TTTTTT><CR>

NOTES:

STX - Start of Text character (02 Hex)

A - Status Word A

B - Status Word B

C - Status Word C

G (gross weight data) - xxxxxx Displayed Weight : x = Weight

- 6 characters if the graduation size does not have a decimal point.
- 5 characters if the graduation size does have a decimal point.
The decimal point is not sent as part of the character string.

T (tare weight data) - xxxxxx Tare Value : x = Tare

- (6 characters if the graduation size does not have a decimal point.)
- (5 characters if the graduation size does have a decimal point.
The decimal point is not sent as part of the character string.



CR - Carriage Return Character: (0D hex)

CS - CheckSum Character: If enabled, this character consists of the last eight bits of the binary sum of all characters transmitted up to this checksum character.

B. Configure Output, Continued

STATUS CODE (WORD) A

Bit #	X00	X0	X	X.X	X.XX	X.XXX	X.XXXX	X.XXXXX
0	0	1	0	1	0	1	0	1
1	0	0	1	1	0	0	1	1
2	0	0	0	0	1	1	1	1

FAIRBANKS/TOLEDO DATA FORMAT

INCREMENT SIZE

Bit #	Count By 1	Count by 2	Count by 5
3	1	0	1
4	0	1	1
5		Always Logic 1	
6		Always Logic 0	
7		Parity Bit	

STATUS CODE (WORD) B

Bit #	Description
0	Gross = 0 Net = 1
1	Positive = 0 Negative = 1
2	In Range = 0 Overcapacity = 1
3	No Motion = 0 Motion = 1
4	Lb = 0 Kg = 1
5	Always Logic 1
6	Normal = 0 Power Up = 1
7	Parity Bit

B. Configure Output, Continued

STATUS CODE (WORD) C

Bit #	Description		
0	Always Logic = 0		
1	Always Logic = 0		
2	Always Logic = 0		
3	Normal = 0		Print Switch Pushed = 1
4	Always Logic = 0		
5	Always Logic = 0		
6	Normal = 0		Keyboard Tare = 1
7	Parity Bit		

CARDINAL 738 CONTINUOUS SCOREBOARD DATA FORMAT

<CR><P><WWWWW>Period (.)<m><SP><u><SP><g><SP><SP><ETX>

NOTES:

CR – Carriage return

P – Polarity (+ = Positive weight, - = Negative weight)

W – Displayed weight

- 6 characters if the graduation size does not have a decimal point.
- 5 characters if the graduation size does have a decimal point.

m – Motion or o = Overload

SP – Space

U - Units (lb = pounds, kg = kilograms)

g – Gross or **n** = Net

ETX - End of text

- Leading zeros are not suppressed
 - If division size has no decimal point, set the decimal to "trailing".
 - If division size has a decimal point, set the decimal to "floating".
-

B. Configure Output, Continued

WEIGHTRONIX DATA FORMAT

<SP><G><WWWWW><SP><U><U><CR><LF>

NOTES:

SP – Space

g – Gross or **n** = Net

W – Displayed weight

- 6 characters if the graduation size does not have a decimal point.
- 5 characters if the graduation size does have a decimal point.

SP – Space

U – Units (lb = pounds, kg = kilograms)

M – Motion

CR – Carriage return

LF – Line feed

- Leading zeros are not suppressed.
 - There is no motion character.
 - If division size has no decimal point, set the decimal to "trailing".
 - If division size has a decimal point, set the decimal to "floating".
-

CONDEC CONTINUOUS DATA FORMAT

<STX><SP><SP><WWWWW><U><G><M><CR><LF>

NOTES:

STX – Start of Text character (02 Hex)

SP – Space

SP – Space

W – Displayed weight

- 6 characters if the graduation size does not have a decimal point.
- 5 characters if the graduation size does have a decimal point.
 - = negative weight

G – Gross; **N** = Net

M – Motion

CR – Carriage return.

- Leading zeros are not suppressed.
 - If division size has no decimal point, set the decimal to "trailing".
 - If division size has a decimal point, set the decimal to "floating".
-

C. SMA PROTOCOL

SMA (Scale Manufacturers Association)

The SMA developed a standard common output for all scale instrument manufacturers to use in the early 2000s so software would easily interface between devices.

The default for the SMA Protocol output is Demand mode, 115200 Baud, no parity, 8 data, 1 stop.

Example of the SMA Protocol output:

Scale division size 20, scale displaying 0 pounds.

Transmitting the polling characters to the 2550:

DATA OUTPUT FORMAT

<LF(0A hex)><W(57 hex)><CR(0D hex)>

2550 response:

Byte 1 LF (0A hex)

Byte 2 Z (5A hex)

Byte 3 1 (31 hex)

Byte 4 G (47 hex)

Byte 5 Space (20 hex)

Byte 6 Space (20 hex)

Byte 7 Space (20 hex)

Byte 8 Space (20 hex)

Byte 9 Space (20 hex)

Byte 10 Space (20 hex)

Byte 11 Space (20 hex)

Byte 12 Space (20 hex)

Byte 13 Space (20 hex)

Byte 14 Space (20 hex)

Byte 15 Space (20 hex)

Byte 16 0 (30 hex)

Byte 17 l (6C hex)

Byte 18 b (62 hex)

Byte 19 Space (20 hex)



Byte 20 CR (0D hex)

STANDARD SCALE RESPONSE MESSAGE

Most of the host commands are responded to in the following message format. The only host commands that do not are the:

Diagnostic, **AB**out and **IN**formation commands

<LF> <s> <r> <n> <m> <f> <xxxxxx.xxx> <uuu> <CR>

where:	<LF>	Start of response message
	<s>	scale status definition / example
	'Z'	Center of Zero <xxxxxx.xxx>= 0.000
	'O'	Over Capacity <xxxxxx.xxx>= +weight
	'U'	Under Capacity <xxxxxx.xxx>= -weight
	'E'	Zero Error (clears when condition clears)
	'I'	Initial-Zero Error (if used, this error is maintained until zero condition is cleared)
	'T'	Tare Error (clears after being read)
	<space>	None of the above conditions
		<i>Note: For 'E', 'I', 'T' error conditions <xxxxxx.xxx>= _____ (center dashes) and 'Z', 'O', 'U' are overridden.</i>
	<r>	range ('1', '2', '3', etc.) always '1' for single range
	<n>	gross/net status
	'G'	Gross normal weight
	'T'	Tare weight (in response to 'M' command)
	'N'	Net normal weight
	'g'	gross weight in high-resolution
	'n'	net weight in high-resolution
	<m>	motion status
	'M'	scale in Motion
	<space>	scale not in Motion
	<f>	future reserved for future or custom use
	<xxxxxx.xxx>	weight data this field is fixed at 10 characters
	<uuu>	Unit of Measure
	<CR>	End of response message



D. EXAMPLES

Command

<LF>W<CR>
<LF>W<CR>
<LF>W<CR>
<LF>H<CR>
<LF>Z<CR>
<LF>R<CR>

Response

<LF> <_> <1> <G> <_> <_> <_ _ _ _ 5.025> <lb_> <CR>
<LF> <_> <1> <N> <_> <_> <_ _ _ _ 100000> <lb_> <CR>
<LF> <_> <2> <G> <M> <_> <_> <_ _ _ _ 8:08.5> </o> <CR>
<LF> <_> <1> <g> <_> <_> <_ _ _ _ 5.0025> <lb_> <CR>
<LF> <Z> <1> <G> <_> <_> <_ _ _ _ 0.000> <lb_> <CR>
<LF> <_> <1> <G> <_> <_> <_ _ _ _ 7.025> <kg_> <CR>
<LF> <_> <1> <G> <M> <_> <_> <_ _ _ _ 7.650> <kg_> <CR>
<LF> <_> <1> <G> <_> <_> <_ _ _ _ 7.650> <kg_> <CR>

The scale will repeat weight until next command is received.

APPENDIX III: 20MA CODES

CODE	UNITS	WEIGHT	SCALE #
00 – Display all data			
40	Lbs	Gross	1
41	Lbs	Net	1
42	Lbs	Tare	1
43	Kg	Gross	1
44	Kg	Net	1
45	Kg	Tare	1
46	Lbs	Gross	2
47	Lbs	Net	2
48	Lbs	Tare	2
49	Kg	Gross	2
50	Kg	Net	2
51	Kg	Tare	2
52	Lbs	Gross	3
53	Lbs	Net	3
54	Lbs	Tare	3
55	Kg	Gross	3
56	Kg	Net	3
57	Kg	Tare	3
58	Lbs	Gross	4
59	Lbs	Net	4
60	Lbs	Tare	4
61	Kg	Gross	4
62	Kg	Net	4
63	Kg	Tare	4



Appendix III: 20mA Codes, Continued

CODE	UNITS	WEIGHT	SCALE #
64	Lbs	Gross	5
65	Lbs	Net	5
66	Lbs	Tare	5
67	Kg	Gross	5
68	Kg	Net	5
69	Kg	Tare	5
70	Lbs	Gross	6
71	Lbs	Net	6
72	Lbs	Tare	6
73	Kg	Gross	6
74	Kg	Net	6
75	Kg	Tare	6
76	Lbs	Gross	7
77	Lbs	Net	7
78	Lbs	Tare	7
79	Kg	Gross	7
80	Kg	Net	7
81	Kg	Tare	7
82	Lbs	Gross	8
83	Lbs	Net	8
84	Lbs	Tare	8
85	Kg	Gross	8
86	Kg	Net	8
87	Kg	Tare	8
99	Lbs	TOTAL	For FB2550

APPENDIX IV: TICKET DATA FIELDS

SCALE TICKET: TICKET NUMBER	Twenty-four (24) characters
<TICKET NO>: <Ticket#>	Six (6) characters
GROSS LABEL: GROSS	Five (5) characters
<GROSS WT>: <Gross>	Six (6) characters
<GROSS UNITS>: lb GR	Two (2) characters
DUAL UNITS GROSS LABEL:P GROSS	
<DUAL UNITS GROSS WT>: <Dual Units Gross>	
<DUAL UNITS GROSS UNITS>: <lb GR	
TARE LABEL: TARE	Four (4) characters
<TARE WT>: <Tare>	Six (6) Characters
<TARE UNITS>: lb TA	Two (2) characters
DUAL UNITS TARE LABEL: TARE	
DUAL UNITS TARE WT>: <Dual Units Tare>	
<DUAL UNITS TARE UNITS>: lb TA	
NET LABEL: NET	Three (3) characters
<NET WT>: <Net>	Six (6) characters
<NET UNITS>: lb NT	Two (2) characters
DUAL UNITS NTET LABEL: NET	
<DUAL UNITS NET WT>: <Dual Units Net>	
<DUAL UNITS NET UNITS>: lb GR	
INBOUND LABEL: INBOUND	Seven (7) characters
<INBOUND WT>: <Inbound>	Six (6) characters
<INBOUND UNITS>: lb GR	Six (6) characters
<DUAL UNITS INBOUND WT>: <Dual Units Inbound>	
<DUAL UNITS GROSS UNITS>: <lb GR>	
<DATE>: <Date>	Ten (10) characters
<TIME>: <Time>	Eight (8) characters
<SCALE ID>: <SCALE ID>	Eleven (11) characters
<LOOP ID LABEL>: LOOP ID	Twenty (20) characters
<LOOP ID>: <Loop ID>	Sixteen (16) characters
<DATE IN>: <Date In>	Ten (10) characters
<TIME IN>: <Time In>	Eight (8) characters
<SCALE ID IN>: <Scale ID In>	Eleven (11) characters
PRODUCT LABEL: LABEL	Twenty-four (24) characters
<PRODUCT ID>: <Product ID>	Sixteen (16) characters
<CONVERSION LABEL>: Conversion Name	Sixteen (16) characters
<CONVERSION>: <Conversion>	Seven (7) characters
<CONVERSION 2 LABEL>: Conversion 2 Name	
<CONVERSION 2>: Conversion 2	



Ticket Data Fields, Continued

<PRODUCT TOTAL WT>: <Prod Tot Wt>	Six (6) characters
<PRODUCT TOTAL UNITS>: <Prod Tot Units>	Two (2) characters
<DUAL UNITS PROD TOT WT>: < Dual Units Prod Tot Wt>	
DUAL UNITS PROD TOT UNITS>: < Dual Units Prod Tot Un>	
CUSTOMER LABEL: CUSTOMER	Twenty-four (24) characters (caption is editable from ticket format)
<CUSTOMER ID>: <Customer ID>	Sixteen (16) characters
<CUSTOMER LINE 1/2/3/4>: <Customer Line 1/2/3/4>	Forty (40) characters
CUSTOMER TOTAL LABEL: CUSTOMER TOTAL	Twenty-four (24) characters (caption is editable from ticket format)
<CUSTOMER TOTAL WT>: <Cust Tot Wt>	Six (6) characters
<CUSTOMER TOTAL UNITS>: <Cust Tot Units>	Two (2) characters
<DUAL UNITS CUST TOT WT>: <Dual Units Cust Tot Wt>	
<DUAL UNITS CUST TOT UNITS>: <Dual Units Cust Tot Un>	
VEHICLE TYPE: VEHICLE TYPE	Twenty-four (24) characters (caption is editable from ticket format)
<VEHICLE DESCRIPTION>: <Vehicle Description>	Thirty-two (32) characters
<LOCATION ID>: <Location ID>	Fifteen (15) characters
<LOCATION NAME/ADDRESS/ CITY STATE/PHONE NMR>: <Location Name/Address/ City State/Phone Nbr>	Sixty-four (64) characters
<LOCATION PHONE NBR>: <Location Phone NBR>	Twenty (20) characters
<PROMPT1 LABEL thru PROMPT10 LABEL>: PROMPT 1 thru PROMPT 10	Twenty (20) characters
<PROMPT1 thru PROMPT10>: <Prompt 1 thru Prompt 10>	
ALL TEXT FIELDS	Twenty-four (24) characters
DUPLICATE COPY LABEL: (DUPLICATE COPY)	
TEXT 1: TEXT 1 thru TEXT 20: TEXT 20	
IMAGE 1: IMAGE 1 and IMAGE 2: IMAGE 2	

APPENDIX V: REMOTE FUNCTION COMMANDS

HARDWARE CONNECTIONS

REMOTE FUNCTIONS	CN14	
Remote Zero Switch	3	11 or 12
Remote Print Switch	9	11 or 12

- These must be Dry Contacts only.
- The I/O Accessory must be installed.

REMOTE SOFTWARE COMMANDS

Remote software commands using Serial Port/ Mapped Memory/ Multicast.

FUNCTION	COMMAND
Zero Active Scale	Z
Zero ALL Scales	z
Zero a Specific Scale	Z# (where # is the Scale Number)
Zero Scales 1-4	ZA
Zero Scales 5-8	ZB
Set Tare on Active Scale	Txxxxx (where xxxxx is the Tare Weight value)
Set Tare on a Specific Scale	T#, xxxxx (where # is the Scale Number, and xxxxx is Tare Weight Value)
AutoTare on Active Scale	A
Change Units on Active Scale	U
Change Units on ALL Scales	u
Change Unites on Specific Scale	U# (where # is Scale Number)
Print Active Scale	P
Change to Multi-screen	m
Change to GTN Screen	g
Select Active Scale	S# (where # is the Scale Number)

APPENDIX VI: FIELDBUS REFERENCE

DT7000 GATEWAY

The **DT7000 Communication I/O Gateway** is a module that provides access between Industrial Networks and the serial device(s).

- The DT7000 utilizes one of the available Anybus Compact COM Modules for the desired Fieldbus.
- The Fieldbus Interface(s) support a bi-directional communication capability for the Instrument.
- The FB2550 Interface supports a variety of **Industrial Protocols**.

The following Fieldbus Networks are supported by the DT7000.

- Profibus-DP
- EtherNet/IP
- ControlNet
- DeviceNet
- MODBUS-TCP



MODULE LAYOUT

The image below shows the module layout.

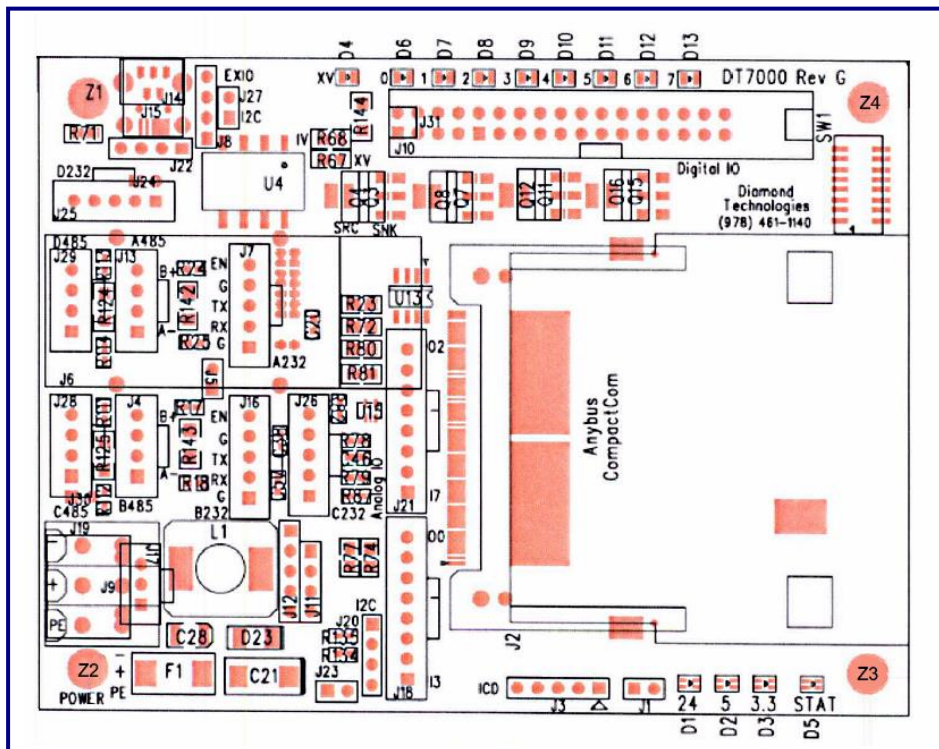

INPUT POWER

The DT7000 requires **Input Power** of **9 to 40 VDC** (**24VDC** normally) at the **Terminal Block Connector (J-19)**.

See the cart below for **Input Power** connections.

J19 PIN	SIGNAL
1	PE
2	+V
3	-V

DT7000 SERIAL PORT CONNECTIONS

The DT7000 has four (4) serial ports.

Only **Port B J16** is used.

See the two following tables for connecting **serial devices** to the **DT7000**.

RS232

PORT B (J16)	SIGNAL
1	GND
2	RX
3	TX
4	GND
5	ENB

If the **ENB Signal** on the RS232 connector is tied to the **Ground**, the **RS232** is *active*, and the RS485 is disabled. If not, the **RS485** is *active*, and the RS232 is disabled.

- Connect pins **four and five (4 & 5)** on the **RS232 (J12, J4)** to enable RS232.

FIELDBUS CONNECTION

The Fieldbus connects to the **Anybus-CompactCOM Module**.

- This connector is Fieldbus-specific.
- There are also LEDs on this module.

MODULE INDICATORS

Listed below are the four power LEDs on the module.

REF	GREEN	RED
D1	+24 POWER OK	REVERSE INPUT POWER
D2	+5V POWRE OK	RESETTLE FUSE TRIPPED
D3	+3.3V POWER OK	--
D4	I/O POWER OK	REVERSE I/O POWER

D1 indicates 24V power is applied to the module. D2 and D3 indicate the internal voltages are being generated. All (3) LEDs will be on green when the module is operating properly. D4 indicates the I/O power is applied to the module and will be illuminated green when I/O power is present.

There is a red/green dual color status LED (D5) on the module. On power up the LED flashes alternately red and green to indicate the module is starting up. Once the module is initialized, the status LED has the following meaning.

D5- STATE	INDICATION
Flashing RED	Not communicating to serial device
Flashing GREEN	Communicating to the serial device
Flashing mostly OFF (RED or GREEN)	Not communicating on Fieldbus
Flashing Mostly on (RED or GREEN)	Communicating on Fieldbus
Solid RED	Module failure

MODULE DIP SWITCHES

There is an 8 position DIP switch on the module. The 8 switches are used to set the network address on the fieldbus. These switches set an address in binary. A switch in the **UP (OFF)** position corresponds to a **1-bit**.

Example: Address 05.

ADDRESS	SWITCH POSITION							
	1	2	3	4	5	6	7	8
05	Up	Dn	Up	Dn	Dn	Dn	Dn	Dn

If the switches are all **DOWN (0 VALUE)**, then the module will read the Fieldbus address from the EEPROM on the CompactCom module. This should also be used if the fieldbus address will be set over the network by a network configuration tool.

MODULE DIP SWITCHES, CONTINUED

The switches can be used to reset all configurable parameters in the DDOOO to factory default values, and to erase the user application. If the switches are all up (255 value) on power up, the status LED (D5) will flash red for 5 seconds, and on the diagnostic port the message **“Change Switches to Reset to Factory Defaults”** displays. Changing any switch value at this time will reset the module to a factory default state. If the switches remain unchanged, the module will start with a switch value of 255.

The meaning of the address and the valid range is fieldbus specific. Refer to the specific fieldbus supplement for the exact meaning of the dip switch settings.

SERIAL COMMUNICATIONS SETTINGS

The communications settings for the serial port is configured for the application. The module is configured by default with the following settings.

PORT	BAUD	DATA BITS	PARITY	FUNCTION
Port B, J16	115200	8	None	Generic setting

Many of the serial settings can be configured through the diagnostic port. These include enabling or disabling the Generic Serial driver on each port, defining the buffers sizes for the Generic Serial driver, and setting the communication parameters, including BAUD rate and parity. Some settings can only be configured through a user application, including enabling MODBUS master functionality or custom serial protocols on a serial port.

HARDWARE SPECIFICATIONS

Power	9-40 VDC (24 VDC Nominal)
Power Consumption	300 mA typical 800 mA max (@24 VDC)
Interface connections	Fieldbus as selected, serial channel
LEDs/Instruments	Power, Network connection
Operating Temperature	0 to 70 C
Storage Temperature	-40 to 85 C
Operating humidity	90% non-condensing
Enclosure rating	None
Mounting options	Thru holes
Others	RoHS
Physical Dimensions	4.24 inches x 3.20 inches
Approval	CE

SOFTWARE SPECIFICATIONS

Output Data Format to Gateway

The **Gateway** takes a Serial String and remap the data to the format needed for the Fieldbus type installed per the register.

- The following is the definition of the **Serial String** for one (1) scale.
 - The Scale ID is extracted from **Status Word 0**.
 - The data is placed in the appropriate Fieldbus Registers based on this scale ID.
 - **Status Word Data** is sent as binary values **MSB** first over the Serial Channel.
 - Weight data is sent as six (6) characters representing a 6-digit decimal value (000000 – 999999).
 - This decimal value represents the weight multiplied by the scale factor, listed in **Command/Status Word 1 bits 0-2**.
 - The serial string is a fixed length of fifty-seven (57) bytes.

STX character	1 byte, (02h)	
Status word 0	2 bytes,	(includes scale ID)
Status word 1	2 bytes,	
Status word 2	2 bytes,	
Unassigned data	6 characters	(default '000000')
Gross Weight	6 characters	(example '002340')
Tare Weight	6 characters,	
Net Weight	6 characters,	
Setpoint 1	6 characters,	
Setpoint 2	6 characters,	
Flow Rate	6 characters,	
Unassigned data	6 characters,	
CRC	1 byte,	
ETX character	1 byte	(03h)

SOFTWARE SPECIFICATIONS, CONTINUED

Note Weight Values sent over the Serial Channel will be represented in the Fieldbus registers based on the settings of **bits 14** and **15** in **STATUS WORD 0**.

- If the data is set to be a 16 bit or 32 bit integer, then the register value will contain the integer value and the host must multiply this by the scale factor to get the actual weight.
- If it is set to be a 16 bit integer, and the integer value is greater then **65535**, a value of **0** is placed in the register.
- If the data is set to be **FLOATING POINT**, then the gateway will multiply the integer value received by the scale factor, and place the resulting 32 bit floating point value in the register.
 - *In this case the host does not use the scale factor to interpret the value.*

INPUT DATA FORMAT FROM GATEWAY

The Gateway will send a string to the Serial Port reflecting data from the Fieldbus.

The following is the definition of the serial string for one (1) scale.

- The scale ID in the Fieldbus register for Command word 0 for a scale must be set to the correct value (1-4) before data for that scale will be sent over the serial channel.
- If the scale ID is set to the correct value, any time any data for this scale changes the data will be sent out the serial channel.
- Command word data is sent as binary values MSB first over the serial channel.
- Weight data is sent as six (6) characters representing a **six (6) digit decimal value (000000 – 999999)**.
- This decimal value represents the weight multiplied by the scale factor listed in **command/status word 1 bits 0-2**.
- The serial string is a fixed length of **105 bytes**.

INPUT DATA FORMAT FROM GATEWAY, CONTINUED

STX character	1 byte,	(02h)
Command word 0	2 bytes,	(includes scale ID)
Command word 1	2 bytes,	
Command word 2	2 bytes,	
Setpoint 1 weight	6 characters,	
Setpoint 2 weight	6 characters,	
Tare Weight	6 characters,	
Display Message 1	26 characters,	
Display Message 2	26 characters,	
Display Message 3	26 characters,	
CRC	1 byte,	
ETX character	1 byte	(03h)

Note Weight Values sent over the serial channel will represent data in the Fieldbus registers based on the settings of **bits 14** and **15** in **STATUS WORD 0**.

- If the data is set to be a 16 bit or 32 bit integer, then the integer value in the register will be sent over the serial channel.
- If it is set to be 16 bit, the high order word will be ignored.
- If the data is set to be floating point, then the floating point value will be multiplied by the scale factor and the integer portion of this resulting value will be sent over the serial channel.
- In all cases if the resulting integer is greater than **999999**, a value of **000000** will be sent over the Serial Channel.
- In all cases the scale must multiply the integer by the scale factor to determine the actual weight.

DISPLAY MESSAGES

A change in the Display Message Strings will not cause a serial string to be sent. The **Display Message Strings** will be sent when any data for a scale is changed (provided the Scale ID is set to the correct value for that scale).

Typically, this will happen when command word 2 bit 1 is set indicating the display messages are to be displayed. There is a maximum of 26 characters per line for the Display Message Strings.



Serial data is transferred according to the RS232 specification between the gateway and the FB2550. The communications parameters are listed below.

Baud	115,200
Data Bits	8
Parity	None
Stop Bits	1

FIELDBUS DATA REPRESENTATION

The following information shows the representation of data on all Fieldbuses. Each Fieldbus has input data (from the gateway/scales to the Fieldbus), and output data (from the Fieldbus to the gateway/scales).

ALL FIELDBUS TYPES OUTPUT MEMORY MAP

START ADDRESS	HEX	DECIMAL	SIZE
Scale 1	0	0	10 Words
Scale 2	14	20	10 Words
Scale 3	28	40	10 Words
Scale 4	3C	60	10 Words
Scale Message Line 1	50	80	26 bytes
Scale Message Line 2	6A	106	26 bytes
Scale Message Line 3	84 1	32	26 bytes
Unassigned	9E	158	2 bytes
Total:			160 bytes

START ADDRESS	HEX	DECIMAL	SIZE
Scale 1	0	0	20 Words
Scale 2	28	40	20 Words
Scale 3	50	80	20 Words
Scale 4	78	120	20 Words
Total:			160 bytes



OUTPUT DATA (WORD BYTE REGISTER USAGE)

WORD	BYTE	REGISTER USAGE	SIZE(BYTES)	SCALE
0	0 - 1	Command Word 0	2	Scale 1
1	2 - 3	Command Word 1	2	
2	4 - 5	Command Word 2	2	
3 - 4	6 - 9	Setpoint 1	4	
5 - 6	10 - 13	Setpoint 2	4	
7 - 8	14 - 17	Tare Weight	4	
9	18 - 19	Unassigned	2	
10	20 - 21	Command Word 0	2	Scale 2
11	22 - 23	Command Word 1	2	
12	24 - 25	Command Word 2	2	
13 - 14	26 - 29	Setpoint 1	4	
15 - 16	30 - 33	Setpoint 2	4	
17 - 18	34 - 37	Tare Weight	4	
19	38 - 39	Unassigned	2	
20	40 - 41	Command Word 0	2	Scale 3
21	42 - 43	Command Word 1	2	
22	44 - 45	Command Word 2	2	
23 - 24	46 - 49	Setpoint 1	4	
25 - 26	50 - 53	Setpoint 2	4	
27 - 28	54 - 57	Tare Weight	4	
29	58 - 59	Unassigned	2	

**OUTPUT DATA (WORD BYTE REGISTER USAGE), CONTINUED**

WORD	BYTE	REGISTER USAGE	SIZE(BYTES)	SCALE
30	60 - 61	Command Word 0	2	Scale 4
31	62 - 63	Command Word 1	2	
32	64 - 65	Command Word 2	2	
33 - 34	66 - 69	Setpoint 1	4	
35 - 36	70 - 73	Setpoint 2	4	
37 - 38	74 - 77	Tare Weight	4	
39	78 - 79	Unassigned	2	
	80 - 105	Display Message Line 1	26	All Scales
	106 - 131	Display Message Line 2	26	
	132 - 157	Display Message Line 3	26	

INPUT DATA (WORD BYTE REGISTER USAGE)

WORD	BYTE	REGISTER USAGE	SIZE(BYTES)	SCALE
0	0 - 1	Status Word 0	2	Scale 1
1	2 - 3	Status Word 1	2	
2	4 - 5	Status Word 2	2	
3 - 4	6 - 9	Unassigned	4	
5 - 6	10 - 13	Gross Weight	4	
7 - 8	14 - 17	Tare Weight	4	
9 - 10	18 - 21	Net Weight	4	
11 - 12	22 - 25	Setpoint 1	4	
13 - 14	26 - 29	Setpoint 2	4	
15 - 16	30 - 33	Flow Rate (weight /second)	4	
17 - 19	34 - 39	Unassigned	6	



INPUT DATA (WORD BYTE REGISTER USAGE), CONTINUED

WORD	BYTE	REGISTER USAGE	SIZE(BYTES)	SCALE
20	40 - 41	Status Word 0	2	Scale 2
21	42 - 43	Status Word 1	2	
22	44 - 45	Status Word 2	2	
23 - 24	46 - 49	Unassigned	4	
25 - 26	50 - 53	Gross Weight	4	
27 - 28	54 - 57	Tare Weight	4	
29 - 30	58 - 61	Net Weight	4	
31 - 32	62 - 65	Setpoint 1	4	
33 - 34	66 - 69	Setpoint 2	4	
35 - 36	70 - 73	Flow Rate (weight /second)	4	
37 - 39	74 - 79	Unassigned	6	
40	80 - 81	Status Word 0	2	Scale 3
41	82 - 83	Status Word 1	2	
42	84 - 85	Status Word 2	2	
43 - 44	86 - 89	Unassigned	4	
45 - 46	90 - 93	Gross Weight	4	
47 - 48	94 - 97	Tare Weight	4	
49 - 50	98 - 101	Net Weight	4	
51 - 52	102 - 105	Setpoint 1	4	
53 - 54	106 - 109	Setpoint 2	4	
55 - 56	110 - 113	Flow Rate (weight /second)	4	
57 - 59	114 - 119	Unassigned	6	



INPUT DATA (WORD BYTE REGISTER USAGE), CONTINUED

WORD	BYTE	REGISTER USAGE	SIZE(BYTES)	SCALE
60	120 - 121	Status Word 0	2	Scale 4
61	122 - 123	Status Word 1	2	
62	124 - 125	Status Word 2	2	
63 - 64	126 - 129	Unassigned	4	
65 - 66	130 - 133	Gross Weight	4	
67 - 68	134 - 137	Tare Weight	4	
69 - 70	138 - 141	Net Weight	4	
71 - 72	142 - 145	Setpoint 1	4	
73 - 74	146 - 149	Setpoint 2	4	
75 - 76	150 - 153	Flow Rate (weight /second)	4	
77 - 79	154 - 159	Unassigned	6	



STATUS/COMMAND WORD BIT USAGE

Status / Command Word 0

bit	Usage
0	Scale ID bits 0, 1, 2
1	Scale 1 = 001, Scale 2 = 010, Scale 3 = 011, Scale 4 = 100
2	
3	motion
4	over capacity gross weight = scale capacity
5	within 2% capacity
6	Enable Tare
7	Disable Tare
8	lb units
9	kg units
10	ton units
11	tonne units
12	
13	
14	Weight conversion, text to numeric (bits 14 and 15)
15	01 = 32 bit floating point
	10 = 32 bit integer
	11 = 16 bit integer



STATUS/COMMAND WORD BIT USAGE

Status / Command Word 1

bit	Usage
0	Decimal Point Location bits 0, 1, 2
1	000 * 1.0; 001 * 0.1; 010 * 0.01; 011 * 0.001; 100 * 0.0001
2	
3	Load Tare Command
4	Auto Tare Command
5	Load Setpoint 1
6	Load Setpoint 2
7	Zero Scale Command
8	Load Cell Status bits 8, 9, 10, 11, 12
9	All Good = 0
10	Defective Cell = Cell Number Binary
11	
12	
13	
14	Print Command
15	Beep

Status / Command Word 2

bit	Usage
0	Display Message Command / Operator Acknowledge
1	Scale weight at or above Maximum weight
2	Scale weight at or below Minimum weight
3 – 15	Unused



STATUS/COMMAND WORD BIT USAGE, CONTINUED

SCALE ID WORD 0 BITS 0,1,2

Command: Changes Instrument display to applicable scale.
Status: Value is the scale id if the scale is selected, from instrument keyboard or Fieldbus, else the value is zero.

MOTION WORD 0 BIT 3

Command: Not applicable.
Status: Indicates that the scale senses motion.

OVER CAPACITY WORD 0 BIT 4

Command: Not applicable.
Status: Indicates that the scale is at 105% of capacity. If this condition is true the gross weight is sent to the Fieldbus as the scale capacity.

WITHIN 2% CAPACITY WORD 0 BIT 5

Command: Not applicable.
Status: Scale is within a range of +/- 2% of capacity and zero.

ENABLE TARE WORD 0 BIT 6

Command: Enable keyboard tare or auto tare weight.
Status: Tare weight enabled.

DISABLE TARE WORD 0 BIT 7

Command: Disable keyboard tare and auto tare weight.
Status: Tare weight disabled.

LB WEIGHT UNITS WORD 0 BIT 8

Command: Switch scale to lb units.
Status: Scale is indicating in lb units.



STATUS/COMMAND WORD BIT USAGE, CONTINUED

KG WEIGHT UNITS WORD 0 BIT 9

Command: Switch scale to kg units.

Status: Scale is indicating in kg units.

TON WEIGHT UNITS WORD 0 BIT 10

Command: Switch scale to ton units.

Status: Scale is indicating in ton units.

TONNE WEIGHT UNITS WORD 0 BIT 11

Command: Switch scale to tonne units.

Status: Scale is indicating in tonne units.

DECIMAL LOCATION WORD 1 BITS 0,1,2

Command: Used in integer to float weight conversions.

Status: Indicates location of decimal point in weight data.

LOAD TARE WORD 1 BIT 3

Command: Load tare from tare memory address.

Status: Switches to 1 after command is executed and returns to 0 when command is cleared.

AUTO TARE WORD 1 BIT 4

Command: Take current scale gross weight as tare value.

Status: Switches to 1 after command is executed and returns to 0 when command is cleared.

LOAD SETPOINT 1 WORD 1 BIT 5

Command: Load setpoint 1 for this scale.

Status: Switches to 1 when command is executed returns to zero when command is cleared.



STATUS/COMMAND WORD BIT USAGE, CONTINUED

LOAD SETPOINT 2 WORD 1 BIT 6

Command: Load setpoint 2 for this scale.

Status: Switches to 1 when command is executed returns to zero when command is cleared.

LOAD CELL STATUS WORD 1 BITS 8,9,10,11,12

Command: Not applicable.

Status: All cells are when the value is zero, else data indicates the number of the failing or failed cell.

PRINT COMMAND: WORD 1 BIT 14

Command: Print scale ticket

Status: Switches to 1 when the command is recognized and resets after the print cycle is complete and the command bit is reset.

BEEP WORD 1 BIT 15

Command: Sound Instrument audible alarm.

Status: Switches to 1 when command is executed, resets to 0 after the command bit is reset.

DISPLAY MESSAGE WORD 2 BIT 0

Command: Display message on Instrument display. Message loaded from display memory 1 to 3 lines.

Status: Switches to 1 when the command is received and the message is displayed.

When scale operator operates any key, the message and bit are cleared.

SCALE ABOVE MAXIMUM WEIGHT WORD 2 BIT 1

Command: Not applicable.

Status: Bit is set when scale weight is at or above the programmed value.

SCALE BELOW MINIMUM WEIGHT WORD 2 BIT 2

Command: Not applicable.

Status: Bit is set when scale weight is at or below programmed value.

Recommended Instrument Settings

Noted below are three recommended settings for optimum performance with the FB2550 Instrument for fieldbus configuration.

A. Always Update, Yes

23. In the **Service Menu**, open **SERVICE OPTIONS**, then select **DISPLAY RATE**.

- ✓ **Default = 0.1**
- ✓ **Always Update = YES**

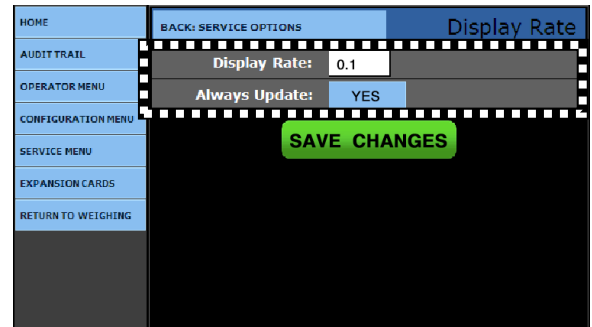

B. Filter Off

24. In the **SERVICE MENU**, open **SERVICE SCALES**, select **SCALE ID X**, open **CALIBRATION**, then select **CALIBRATION DATA**.

25. Press **PAGE FORWARD** twice.

- ✓ **Filter Factor = OFF**

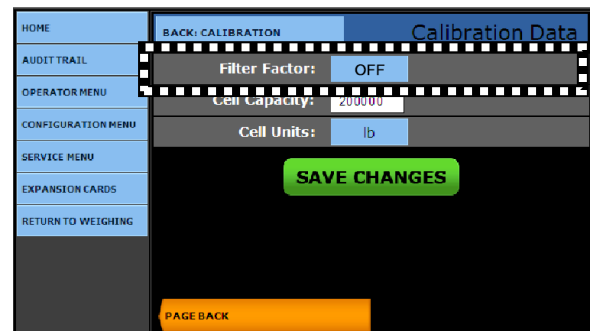

C. Expansion Filtering, Disabled

26. In the **EXPANSION CARDS MENU**, open the available card to be configured.

- ✓ **Update Rate = 100**
- ✓ **Sample Rate = 120 samples/sec.**
- ✓ **Filtering = Disabled**

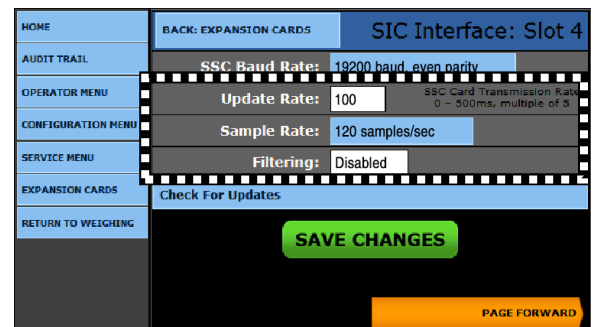



FB2550 Inbound/Outbound Series
Operator Manual
Document 51254

Manufactured by Fairbanks Scales, Inc.
821 Locust Street
Kansas City, MO 64106

www.fairbanks.com