



**A. Introduction**

The 9109 family of OMCs are constructed of stainless steel load cells, have 4 hole mounting pattern for securing, and built in checking. **All cells used are true hermetically sealed units.** The OMC assemblies are compact, resistant to oxidation, and have replaceable 'suspension' parts for super long life and excellent resolution. See the following chart for either stainless steel or galvanized mounting assemblies.

**B. Specifications**

**Resistance:** 500 Ohms

**Output:** 2 mV/v (see certificate for exact output spec)

**Type:** Double-Ended Shearbeam

**Wiring:** (Color code on the load cell cable)

Black - Excitation

Green + Excitation

White + Signal

Red - Signal

Yellow Shield

**C. Capacities:**

**Product**

<u>No.</u>	<u>Capacity</u>	<u>Description</u>
98463	1 K	9109-1, SS, NTEP, FM, Hermetically Sealed, DESB, <b>SS Mount</b>
98464	2.5K	9109-2, SS, NTEP, FM, Hermetically Sealed, DESB, <b>SS Mount</b>
98465	5K	9109-3, SS, NTEP, FM, Hermetically Sealed, DESS, <b>SS Mount</b>
98466	10K	9109-4, SS, NTEP, FM, Hermetically Sealed, DESB, <b>SS Mount</b>
98467	25K	9109-5, SS, NTEP, FM, Hermetically Sealed, DESB, <b>SS Mount</b>
98468	50K	9109-6, SS, NTEP, FM, Hermetically Sealed, DESB, <b>SS Mount</b>
98469	1K	9109-7, SS, NTEP, FM, Hermetically Sealed, DESB, <b>GALV Mount</b>
98470	2.5K	9109-8, SS, NTEP, FM, Hermetically Sealed, DESB, <b>GALV Mount</b>
98471	5K	9109-9, SS, NTEP, FM, Hermetically Sealed, DESB, <b>GALV Mount</b>
98472	10K	9109-10, SS, NTEP, FM, Hermetically Sealed, DESB, <b>GALV Mount</b>
98473	25K	9109-11, SS, NTEP, FM, Hermetically Sealed, DESB, <b>GALV Mount</b>
98474	50K	9109-12, SS, NTEP, FM, Hermetically Sealed, DESB, <b>GALV Mount</b>

(DESB = Double Ended Shearbeam      GALV = Galvanized)

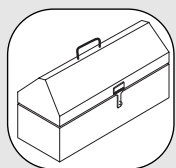

#### D. Installation:

The Omnicell is fully assembled when shipped and ready for installation. With the vessel, tank, or hopper supported safely on blocks, jacks or by other means:

- Set each OMC assembly base onto a flat surface centered under the support leg/support flange
- Loosely bolt the flange of the support legs to the OMCs' load mounting plates
- Select the checking that best suits the application and rotate the posts and/or mounting yokes for proper checking clearances (there are many settings variations that can be used to get the right checking clearances).
- Ensure the vessels load 'legs' are directly over the center of the load cell's load mounting plate
- Mark the holes where the anchor bolts will be placed, or drill down through the holes in the base
- Drill and set anchor bolts, then mount the base and secure, with lock washers and nuts
- Wire the load cell into the junction box or sectional controller or QMB using the color code listed above, or printed on the cable.
- Use the calibration sheet packed with each cell for Intalogix™ Technology instruments' exact settings of cell outputs.
- Carefully lower the vessel onto the cells ensuring that any one or more cells are not overloaded during the process
- Use the proper manual for instrument calibration

**E. Parts List:**

<b><u>Part #</u></b>	<b><u>Description</u></b>
98573	Mild Steel Omni Mounts, includes suspension 1-10K
98574	Mild Steel Omni Mounts, includes suspension 25K
98575	Mild Steel Omni Mounts, includes suspension 50K
98576	Stainless Steel Omni Mounts, includes suspension 1-10K
98577	Stainless Steel Omni Mounts, includes suspension 25K
98578	Stainless Steel Omni Mounts, includes suspension 50K
98579	Load Cell SS DESB 1K
98580	Load Cell SS DESB 2.5K
98581	Load Cell SS DESB 5K
98582	Load Cell SS DESB 10K
98583	Load Cell SS DESB 25K
98584	Load Cell SS DESB 50K

# Typical Load Cell Mounting Orientation

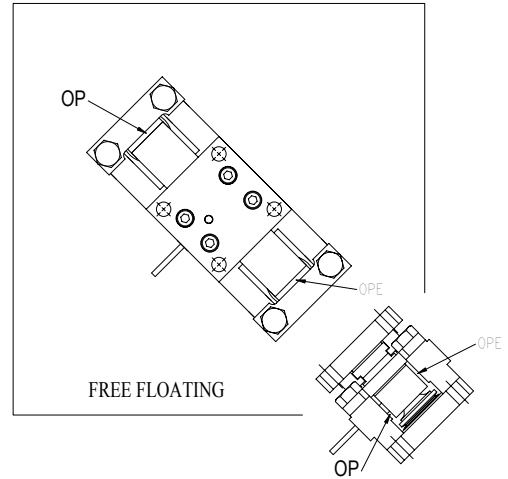
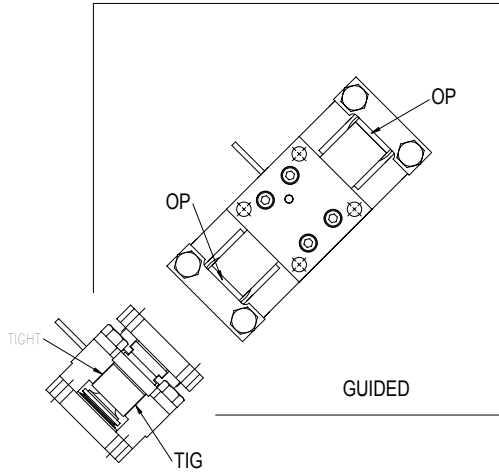
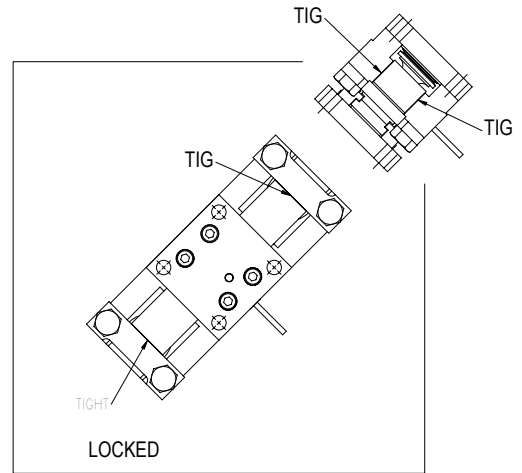
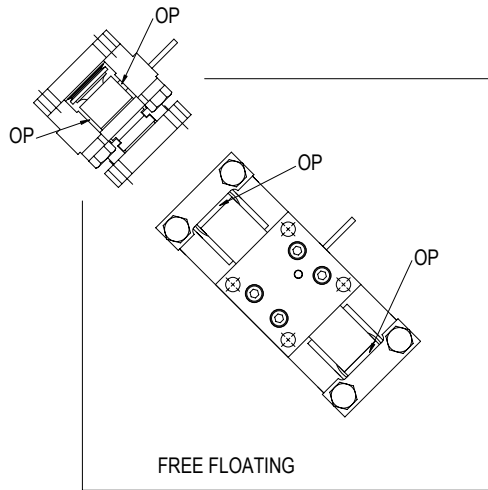

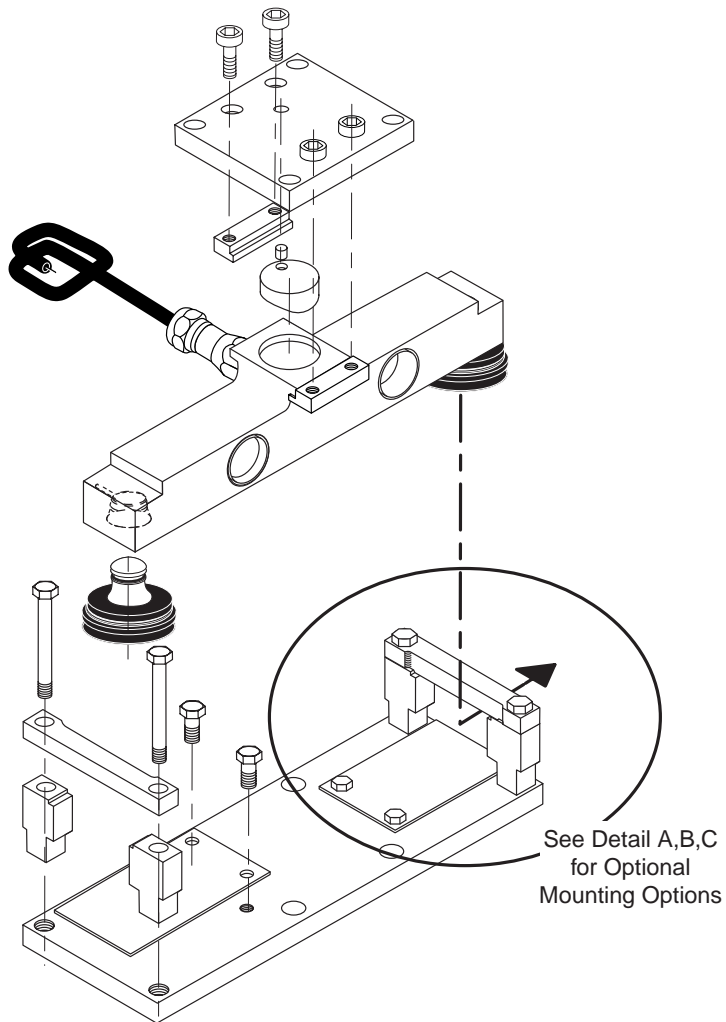

**Note:** It is important to set the checking clearances so that expansion and contraction of the supported vessel will be taken into account. On a four (4) load cell tank, hopper, vessel; keep the clearance on 1 cell assembly (#1) as an 'anchor' with tight, minimal clearances. On the other three (3), set with the looser, more open clearances to allow for expansion and / or contraction. Mount the assemblies so that the cell is centered in the checking and can 'move' in all directions. All vessels, regardless of material type or construction, will be likely to expand or contract with changes in temperature, load, and other variables.

**Parts:** Parts kits contain the hardware minus the load cell,

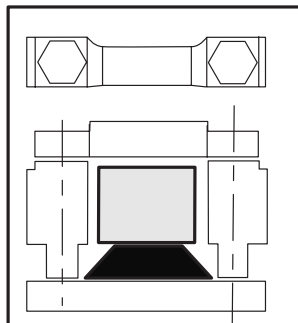

Minimum Checking

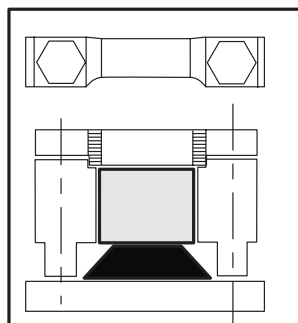

Maximum Checking

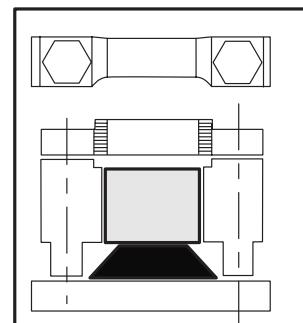

Maximum Up-Lift

individual parts are NOT available.

**A. Mild Steel Kits, by Capacity:** 1 thru 10K Kit # 98573  
25K Kit # 98574  
50K Kit # 98575

**Includes:**

- 1 Top Rocker
- 1 Top Plate
- 1 Spring Pin
- 4 Socket Cap Screws 5/8-11 x 1 1/4"
- 2 Cross Beams
- 4 Legs
- 2 Stainless Sheet
- 2 Sliding Load Pin w/ "O" Ring and Slide Plate
- 2 V-Ring
- 1 Base Plate
- 4 Hex Head Screws 1/4" -20 x 1/2"
- 2 Uplift Hook

**B. Stainless Steel Kits, by Capacity:** 1 thru 10K Kit # 98576  
25K Kit # 98577  
50K Kit # 98578

**Includes:**

- 1 Top Rocker
- 1 Top Plate
- 1 Spring Pin
- 4 Socket Cap Screws 5/8-11 x 1 1/4"
- 2 Cross Beams
- 4 Legs
- 2 Stainless Sheet
- 2 Sliding Load Pin w/ "O" Ring and Slide Plate
- 2 V-Ring
- 1 Base Plate
- 4 Hex Head Screws 1/4" -20 x 1/2"
- 2 Uplift Hook

<b>Load Cells:</b>	<b><u>Part #</u></b>	<b><u>Capacity</u></b>	<b><u>Description</u></b>
	98579	1K	SS Hermetically Sealed LC
	98580	2.5K	SS Hermetically Sealed LC
	98581	5K	SS Hermetically Sealed LC
	98582	10K	SS Hermetically Sealed LC
	98583	25K	SS Hermetically Sealed LC
	98584	50K	SS Hermetically Sealed LC