



DEFENDER™ 3000

Field Test Scale



Portable Precision Ready for the Field

The OHAUS Digital Field Test Scale is designed for precision material testing in the construction industry. With a capacity of 150 lb and readability up to 0.05 lb, you won't have to sacrifice precision for portability. Key features include the durable plastic carrying case and dry cell battery with power up to 150-hours, making the Field Test Scale a powerful addition to any job site.

Unique Features:

- A capacity of 150 lb with a readability of 0.05 lb and the powder-coated steel base in a case means that the Digital Field Test Scale provides precise, clear measurements, no matter where you're working.
- The Field Test Scale comes packaged in a durable plastic carrying case with latches and carrying handle, ensuring maximum portability for use anywhere on the job - without limiting you to the lab.
- The backlit LCD display allows for easy reading of results, even in low-light conditions. Can be powered using "C" cell batteries for up to 150 hours - optional internal rechargeable battery available.

DEFENDER™ 3000 *Field Test Scale*

Specifications

Model	i-D33P75SD
Capacity x Readability	150 lb x 0.05 lb / 75 kg x 0.02 kg
Resolution	1:3,750
Base Size (L x W x H)	12.4 x 11 x 1.77 in / 316 x 280 x 45 mm
Construction	ABS plastic indicator housing, powder coated steel base with raised, embossed tread platform, durable plastic carrying case with foam insert and latches
Weighing Units	lb, kg, oz, g, lb:oz
Application Modes	Weighing, Checkweighing, Counting, Totalization
Display	6-digit, 7-segment LCD display with multi-color backlight, 45 mm high digits
Keyboard	4 function keys
Communications	RS232 included, Optional USB or Ethernet
Stabilization Time	Within 1 second
Indicator Cable Length	9 feet
Operating Temperature	14 °F to 104 °F / -10 °C to 40 °C / 10% - 80% relative humidity, non-condensing
Power	100-240 VAC / 50/60 Hz Universal Power Supply or C cell battery (Not included) or internal rechargeable battery
Battery Operating Time	Up to 150 hours continuous use with backlight off (C cell battery) or up to 75 hours continuous use with backlight off (optional rechargeable battery)
Auto-Shut Off	Selectable – Off, 1 5 or 10 minutes of no activity
Safe Overload Capacity	125% of capacity
Carrying Case Size (L x W x D)	16.9 x 19.5 x 8.5 in / 430 x 490 x 210 mm
Shipping Dimensions (L x W x D)	17.3 x 19.7 x 8.7 in / 440 x 500 x 220 mm
Net Weight	19.8 lb / 9 kg
Shipping Weight	20.3 lb / 9.2 kg

Outline Dimensions

Base

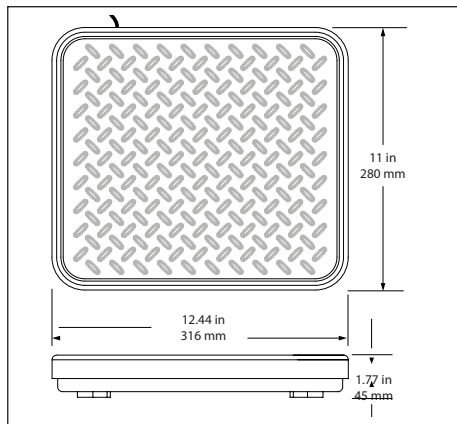

i-DT33P Indicator

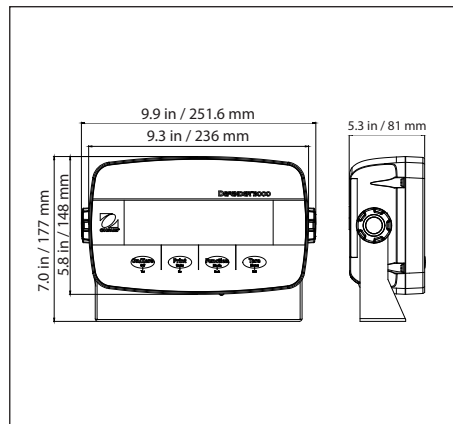

Compliance

- **Product Safety:** UL61010-1; CAN/CSA C22.2 61010-1; IEC/EN 61010-1
- **Electromagnetic Compatibility:** FCC Part 15 Class A; Canada ICES-003 Class A; IEC/EN 61326-1 Class B, basic environments
- **Other:** WEEE, RoHS

Accessories

Printer, Impact, SF40A.....	30064203
Ethernet Kit	30429666
Printer, Zebra Label GK420T	30611855
USB Device Interface Kit.....	30699120
Dust Cover Set (5)	30699121
Rechargeable Battery Kit.....	30699122
Cable, RS232 IBM 9P Male-to-Female... ..	80500525
DB9 Adapter, Male-to-Male.....	30692384

Other Standard

Features & Equipment

Flexible coiled cable (extendable up to 9 ft.), 6 ft. AC line cord, 125% overload protection, selectable span calibration points, auto-zero tracking, battery-saving auto-off, Geo Code geographical gravity calibration adjustment, and software menu lockouts.

OHAUS CORPORATION

7 Campus Drive
Suite 310
Parsippany, NJ 07054 USA

Tel: 800.672.7722
973.377.9000

Fax: 973.944.7177

www.ohaus.com

The management system governing the manufacture of this product is ISO 9001:2015 certified.

