

Portable Wheelchair Scale

M503



- ✓ Handle and wheels, for easy transportation
- ✓ None slip rubber mat
- ✓ Hold the railing while weighing
- ✓ Ni-MH rechargeable battery package (size AA)
- ✓ Folding Ramps and hand rail



Totalcomp[®] Scales & Components

SPECIFICATIONS

M503

General Specifications

- Display 0.98" digit LCD display, with white LED backlight
- Capacity 550lb x 0.1lb
- Platform size 880 x 840mm
- Keyboard 7 keys (Membrane keyboard)
- Housing ABS plastic indicator
- Max. Divisions 5,000d
- ADC Sigma delta
- ADC update $\leq 1/10$ second
- Operating Temp. $-10^{\circ}\text{C} \sim +40^{\circ}\text{C}$
- Power 2000mAh Ni-MH battery package (optional, size AA), external AC power adapter
- Weight 64 lbs
- Packing Gross weight 104 lbs
- Optional RS - 232 Output

Dimensions

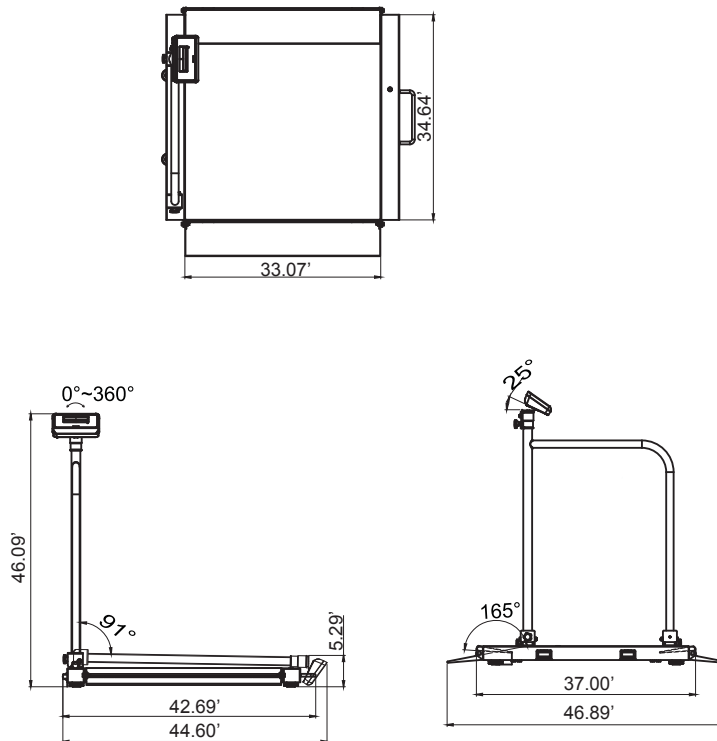

TOTALCOMP LIMITED WARRANTY

Totalcomp warrants this product to be free of defects in materials and/or workmanship and suitable for the purpose(s) intended as outlined on this sheet. This warranty is effective and shall cover the purchaser for one year from the date of shipment from our plant. If this product is found to be defective by our inspection in accordance with the above listed criteria, we will replace or repair it at our expense. For warranty service, please obtain a return authorization number from us and return the item, shipping prepaid, with a written description of the problem. We will respond promptly with the results of our evaluation.



Totalcomp[®]

Scales & Components

99 Reagent Lane
Fair Lawn, NJ 07410
Fax (201) 797-2287
Toll Free Fax (888) 797-2288
Phone (201) 797-2718
Toll Free Phone (800) 631-0347
Email sales@totalcomp.com
Website www.totalcomp.com