



Cardinal[®]
Cardinal Scale Manufacturing Co.

200

WEIGHT INDICATOR

INSTALLATION and TECHNICAL MANUAL



8200-M035-O1 Rev C 203 E. Daugherty, Webb City, MO 64870 USA
02/14 Ph: 417-673-4631 • Fax: 417-673-2153
<http://www.cardinalscale.com>

Printed in USA

Technical Support: Ph: 866-254-8261 • tech@cardet.com

INTRODUCTION

Thank you for selecting and purchasing the Cardinal Model 200 Weight Indicator. The Model 200 was built with quality and reliability and incorporates the latest in digital technology and innovative features for the weighing industry. Configuration and upgrades can easily be performed in the field, while still maintaining the rigid control the most demanding installations require. This flexibility insures the Model 200 will be able to meet your weight indicating needs for years to come.

The purpose of this manual is to provide you with a guide through installation, setup and operation of your new Model 200 Weight Indicator. Please read it thoroughly before attempting to install your weight transmitter and keep it handy for future reference.

COPYRIGHT

All rights reserved. Reproduction or use, without expressed written permission, of editorial or pictorial content, in any manner, is prohibited. No patent liability is assumed with respect to the use of the information contained herein.

DISCLAIMER

While every precaution has been taken in the preparation of this manual, the Seller assumes no responsibility for errors or omissions. Neither is any liability assumed for damages resulting from use of the information contained herein. All instructions and diagrams have been checked for accuracy and ease of application; however, success and safety in working with tools depend to a great extent upon the individual accuracy, skill and caution. For this reason the Seller is not able to guarantee the result of any procedure contained herein. Nor can they assume responsibility for any damage to property or injury to persons occasioned from the procedures. Persons engaging the procedures do so entirely at their own risk.

SERIAL NUMBER _____
DATE OF PURCHASE _____
PURCHASED FROM _____

RETAIN THIS INFORMATION FOR FUTURE USE

PRECAUTIONS

Before using this indicator, read this manual and pay special attention to all "NOTIFICATION" symbols:



IMPORTANT



**ELECTRICAL
WARNING**



**STATIC
SENSITIVE**

FCC COMPLIANCE STATEMENT

This equipment generates uses and can radiate radio frequency and if not installed and used in accordance with the instruction manual, may cause interference to radio communications. It has been tested and found to comply with the limits for a Class A computing device pursuant to Subpart J of Part 15 of FCC rules, which are designed to provide reasonable protection against such interference when operated in a commercial environment. Operation of this equipment in a residential area may cause interference in which case the user will be responsible to take whatever measures necessary to correct the interference.

You may find the booklet “How to Identify and Resolve Radio TV Interference Problems” prepared by the Federal Communications Commission helpful. It is available from the U.S. Government Printing Office, Washington, D.C. 20402, stock No. 001-000-00315-4.

PROPER DISPOSAL

When this device reaches the end of its useful life, it must be properly disposed of. It must not be disposed of as unsorted municipal waste. Within the European Union, this device should be returned to the distributor from where it was purchased for proper disposal. This is in accordance with EU Directive 2002/96/EC. Within North America, the device should be disposed of in accordance with the local laws regarding the disposal of waste electrical and electronic equipment.

It is everyone’s responsibility to help maintain the environment and to reduce the effects of hazardous substances contained in electrical and electronic equipment on human health. Please do your part by making certain that this device is properly disposed of. The symbol shown to the right indicates that this device must not be disposed of in unsorted municipal waste programs.



TABLE OF CONTENTS

SPECIFICATIONS - - - - -	Page 1
Standard Features - - - - -	Page 2
Optional Features - - - - -	Page 2
Certifications - - - - -	Page 2
EUROPEAN DECLARATION OF CONFORMITY - - - - -	Page 3
PRECAUTIONS - - - - -	Page 4
SITE PREPARATION REQUIREMENTS - - - - -	Page 5
INSTALLATION - - - - -	Page 7
Unpacking - - - - -	Page 7
Mounting - - - - -	Page 7
Load Cell Connection - - - - -	Page 8
Load Cell Connections With Over 30 Feet Of Cable - - - - -	Page 9
Serial I/O Cable Installation - - - - -	Page 9
Optically Isolated Remote Inputs - - - - -	Page 10
Optional Analog Output (200-A Only) - - - - -	Page 10
Main PCB (Figure No. 9) - - - - -	Page 11
Main PCB Jumpers - - - - -	Page 11
KEYPAD FUNCTIONS - - - - -	Page 13
ANNUNCIATORS - - - - -	Page 17
SETUP AND CALIBRATION - - - - -	Page 19
SETUP REVIEW - - - - -	Page 45
CALIBRATION "C" NUMBERS - - - - -	Page 47
ACCUMULATORS - - - - -	Page 49
TROUBLESHOOTING - - - - -	Page 51
Error Codes - - - - -	Page 51
Before You Call Service - - - - -	Page 53
Diagnostic Test Mode - - - - -	Page 54
CALIBRATION SEAL INSTALLATION - - - - -	Page 55
LOCAL/REMOTE SETUP - - - - -	Page 57
PART IDENTIFICATION - - - - -	Page 58

SPECIFICATIONS

Power Requirements:	90 to 264 VAC 50/60 Hz 15 VDC 1A plug-in UL/CSA listed AC power adapter (Cardinal part number 6800-1035).
Enclosure Type:	Aluminum, NEMA 12/IP52
Enclosure Size:	5.32" W x 2.62" H x 9.13" D (135 mm W x 66.6 mm H x 232 mm D)
Weight:	8.2lbs
Operating Environment:	Temperature: 14 to 104 °F (-10 to +40 °C) Humidity: 90% non-condensing (maximum)
Display:	6-digit, 0.6" high, 7-segment LED
Transducer Excitation:	12 VDC
Signal Input Range:	1.0 mV min. to 40 mV max. (with dead load boost)
Number of Load Cells:	8 each, 350 OHM minimum resistance
Load Cell Cable Length:	1500 feet maximum. Consult factory for other requirements 30 feet maximum without sense lines
Division Value:	1, 2, or 5 x 10, 1, 0.1, 0.01, 0.001 commercial 0 to 99, non-commercial
Sensitivity:	
NON-COMMERCIAL	0.15 uV/e
NTEP	0.3uV/e (Class III/IIIL)
CANADA	0.3uV/e (Class III/IIIHD)
OIML	0.7 uV/e (Class III)
Scale Divisions:	
NON-COMMERCIAL	100 to 240,000
NTEP	100 to 10,000 (Class III/IIIL)
CANADA	100 to 10,000 (Class III/IIIHD)
OIML	100 to 10,000 (Class III)
Internal Resolution:	1 part in 16,777,216
Tare Capacity:	Scale Capacity
Sample Rate:	1 to 100 samples per second, selectable
Auto Zero Range:	0.5 or 1 through 9 divisions
Weighing Units:	Tons, Pounds, Pounds-Ounces, Ounces, Metric Tons, Kilograms, Grams
Keypad:	Color coded Membrane type - 7 keys
Standard I/O:	(1) bi-directional RS232 (20mA) (1) output only RS232 (20mA)

SPECIFICATIONS, CONT.

Standard Features:

- Push button tare function
- Gross, Tare, Net conversion
- Selectable key lockout
- Hi-Resolution mode
- StableSENSE^{® 1} adjustable digital filtering
- Gross and Net accumulators
- Dual serial ports
- Remote input lines for Zero, Tare, Gross and Print (1000 feet maximum)
- Programmable print format using Visual Print or nControl (2 Visual Tickets available)
- SMA level 2 compliant serial communications
(For more information see <http://www.scalemanufacturers.org>)
- Field re-programmable via PC interconnection
- Test feature (performs display and internal tests)
- Auto Shutoff and Sleep modes

Optional Features:

Analog Output*, Allen-Bradley Interface*, 10/100 mbps Ethernet Adapter*, Additional Serial Port*, External Relay Box* and Special Filtering

*This feature requires additional hardware and includes additional documentation.

Certifications:

This equipment is certified to comply with the requirements for a Class III/IIIL device by the

- National Conference on Weights and Measurements (Certificate No. 01-011)
- Measurement Canada (Approval No. AM-5397)
- And for a Class III device by OIML R-76 (Certificate No. DK 0199.47).



¹ StableSENSE[®] is a digital filter utilizing proprietary software algorithms to remove or greatly reduce changes in the weight display resulting from movement on the scale platform. StableSENSE[®] can be used to lessen the effects of movement on the scale or it can be used to lessen the effects of wind and vibration. Any application affected by vibration or movement on the scale platform can benefit using StableSENSE[®].

EUROPEAN DECLARATION OF CONFORMITY

Manufacturer: Cardinal Scale Manufacturing Company
PO Box 151
203 East Daugherty
Webb City, Missouri 64870 USA
Telephone No. (417) 673-4631
Fax No. (417) 673-5001

Product: Non-automatic Weight Indicating Instrument
Model Numbers 200, 205, 210, 210FE, 215, 220 and 225
Serial Number EXXXYY-ZZZ
where XXX = day of year
YY = last two digits of year
ZZZ = sequential number

The undersigned hereby declares, on behalf of Cardinal Scale Manufacturing Company of Webb City, Missouri, that the above-referenced product, to which this declaration relates, is in conformity with the provisions of:

European Standard EN 45501: 1992 and equivalent International Recommendation OIML R76, edition 1992
EU Type Approval Certificate Number DK 0199.159
Report No. DANAK-1910304

Council Directive 2006/95/EC Low Voltage Directive
as amended by Council Directive 93/68/EEC (22 July, 1993)

Council Directive 90/384/EEC (20 June, 1990) on the Harmonization Of the Laws of Member States relating to non-automatic weighing Systems as amended by:
Council Directive 93/68/EEC (22 July, 1993)

European Standard EN50082: 1995 for radiated emissions and
European Standard EN50082-2: 1995 Class B for EMC immunity.

The Technical Construction File required by this Directive is maintained at the corporate headquarters of Cardinal Scale Manufacturing Company, 203 East Daugherty, Webb City, Missouri.



Mark Levels
Quality Assurance Administrator

PRECAUTIONS

Static Electricity



CAUTION! This device contains static sensitive circuit cards and components. Improper handling of these devices or printed circuit cards can result in damage to or destruction of the component or card. Such actual and/or consequential damage **IS NOT** covered under warranty and is the responsibility of the device owner. Electronic components must be handled only by qualified electronic technicians who follow the guidelines listed below.



WARNING! ALWAYS use a properly grounded wrist strap when handling, removing or installing electronic circuit cards or components. Make certain that the wrist strap ground lead is securely attached to an adequate ground. If you are uncertain of the quality of the ground, you should consult a licensed electrician.



ALWAYS handle printed circuit card assemblies by the outermost edges. **NEVER** touch the components, component leads or connectors. **ALWAYS** observe warning labels on static protective bags and packaging and never remove the card or component from the packaging until ready for use. **ALWAYS** store and transport electronic printed circuit cards and components in anti-static protective bags or packaging.

SITE PREPARATION REQUIREMENTS

The Model 200 Weight Indicator is a precision weight-measuring instrument. As with any precision instrument, it requires an acceptable environment to operate at peak performance and reliability. This section is provided to assist you in obtaining such an environment.

Environmental

The Model 200 Weight Indicator meets or exceeds all certification requirements within a temperature range of 14 to 104 °F (-10 to +40 °C).

In order to keep cooling requirements to a minimum, the indicator should be placed out of direct sunlight and to provide adequate air circulation, keep the area around the indicator clear.

Make certain the indicator is not directly in front of a heating or cooling vent. Such a location will subject the indicator to sudden temperature changes, which may result in unstable weight readings.

Insure that the indicator has good, clean AC power and is properly grounded.

In areas subject to lightning strikes, additional protection to minimize lightning damage, such as surge suppressors, should be installed.

Electrical Power

The 200 indicator has been designed to operate from 90 to 264 VAC 50/60 Hz 15 VDC 1A plug-in UL/CSA listed AC power adapter (Cardinal part number 6800-1035).

- The socket-outlet supplying power to the indicator should be on a separate circuit from the distribution panel and dedicated to the exclusive use of the indicator.
- The socket-outlet shall be installed near the equipment and shall be easily accessible.
- The wiring should conform to national and local electrical codes and ordinances and should be approved by the local inspector to assure compliance.
- On installations requiring 230 VAC power, **it is the responsibility of the customer** to have a qualified electrician install the proper power cord plug that conforms to national electrical codes and local codes and ordinances.

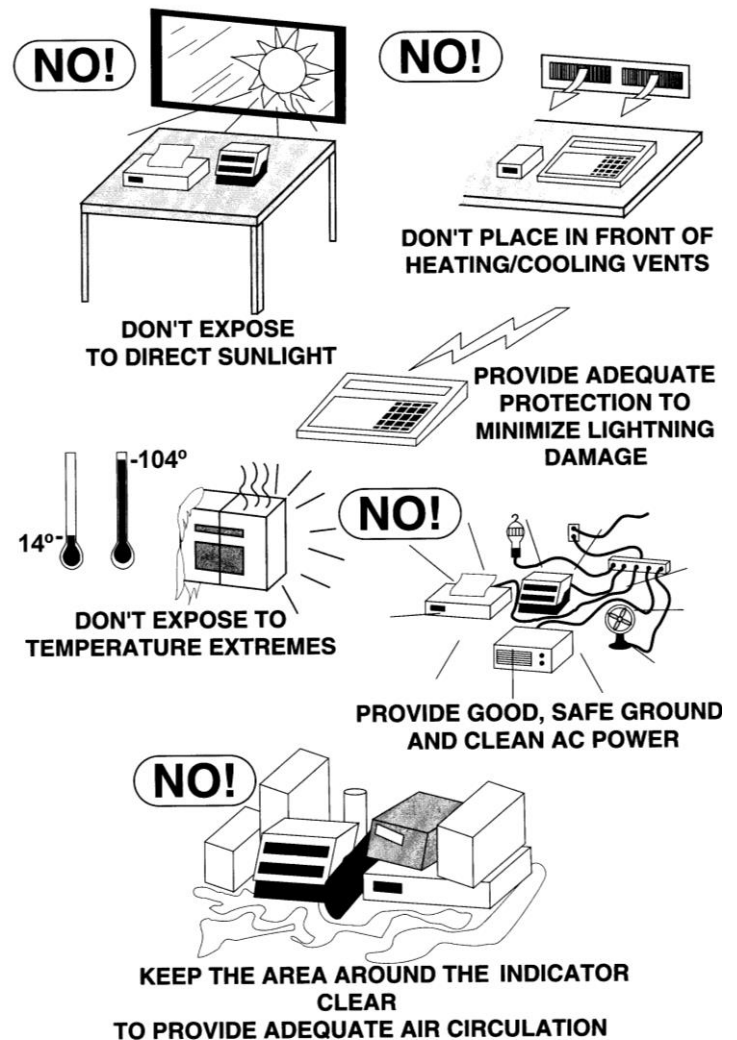

SITE PREPARATION REQUIREMENTS, CONT.

Electrical Noise Interference

To prevent electrical noise interference, make certain all other wall outlets for use with air conditioning and heating equipment, lighting or other equipment with heavily inductive loads, such as welders, motors and solenoids are on circuits separate from the indicator. Many of these disturbances originate within the building itself and can seriously affect the operation of the indicator. These sources of disturbances must be identified and steps must be taken to prevent possible adverse effects on the indicator. Examples of available alternatives include isolation transformers, power regulators, uninterruptible power supplies, or simple line filters.

Transient Suppression

The following recommendations will help to reduce transients:

- Always use shielded cables to connect signal wires to the weight indicator.
- Do not run load cell or signal cables from the weight indicator along side or parallel to wiring carrying AC power. If unavoidable, position the load cell and signal cables a minimum of 24" away from all AC wiring.
- Always use arc suppressors across all AC power relay contacts (see recommendations at http://www.paktron.com/pdf/Quencharch_QRL.pdf).
- Use zero voltage switching relays, optically isolated if possible.

RFI Immunity

The operation of sensitive electronic equipment can be adversely affected by RF (Radio Frequency) radio transmissions. Digital weight indicators are one such type of equipment. Radio transmissions come from things like hand-held radio transmitters and cell phones. One symptom of RFI (Radio Frequency Interference) in a digital weight indicator is weight indication instability during a radio transmission.

Cardinal digital weight indicators are designed with special grounding and RFI shielding to achieve a high degree of immunity to common RFI. To maximize the digital weight indicator's immunity to radio transmissions, follow these guidelines:

1. ALWAYS use shielded cable for all I/O (Input/Output) connections to the digital weight indicator.
2. NEVER operate any radio transmitter within 2 meters (~6ft.) of the weight indicator.
3. NEVER connect un-terminated serial, digital, or analog I/O cables to the internal printed circuit boards of the digital weight indicator.
4. KEEP the intended external I/O device connected to I/O cables entering the digital weight indicator.
5. ALWAYS connect the shield of the shielded cable to the indicator back panel gland connector or other closest ground terminal inside the indicator.
6. ALWAYS connect the shield of the shielded I/O cable at the indicator end only. Leave the shield unconnected at the I/O device.

INSTALLATION

Unpacking

Carefully remove the indicator from the shipping carton and inspect it for any evidence of damage that may have taken place during shipment. Keep the carton and packing material for return shipment if it should become necessary. The purchaser is responsible for filing all claims for any damages or loss incurred during transit.

Mounting

1. The Model 200 Weight Indicator is housed in a NEMA 12/IP52 enclosure that is normally mounted to a panel or wall. Make certain the mounting surface is strong enough to support the indicator. The mounting location should be where the display is easily viewed while being close enough to provide the operator easy access to the keypad.

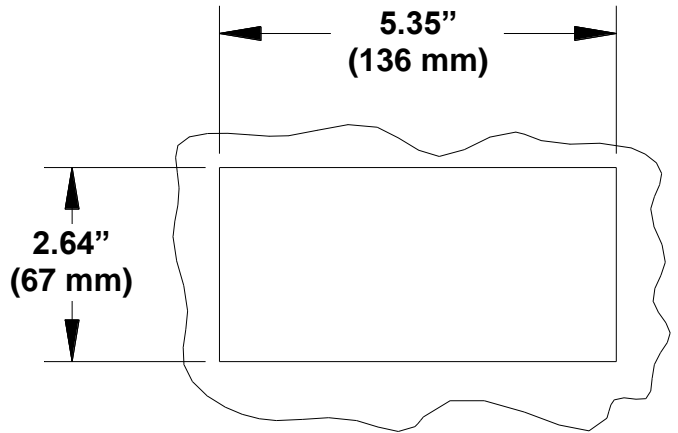

Figure No. 1

2. Carefully lay out the mounting hole in the panel or wall, and then cut out an opening, referring to Figure No. 1 for the cutout dimensions.

3. Remove the 2 screws securing the mounting clamps to the enclosure. See Figure No. 2.

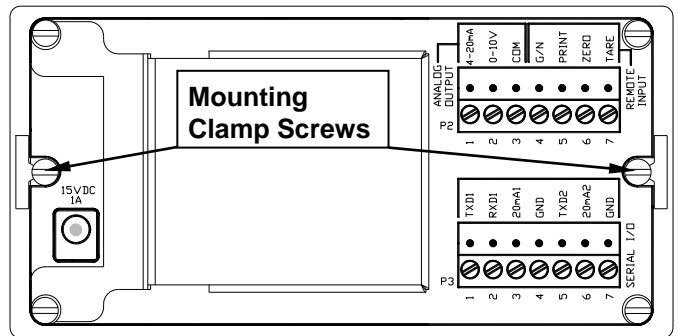

Figure No. 2

4. Slide both mounting clamps toward the rear of the indicator and remove. See Figure No. 3.

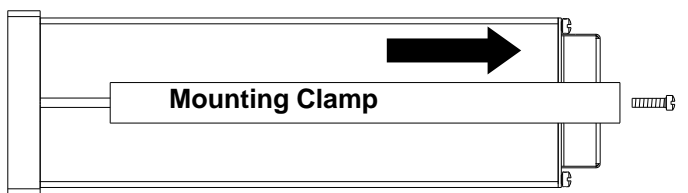

Figure No. 3

5. Insert the indicator through the cutout in the panel until the front bezel is resting against the panel. Make sure the indicator is facing in the correct upright position.

6. Place both mounting clamps in the groove on the side of the enclosure and slide them forward to rest against the panel. **NOTE:** The mounting clamps are identical and have the same notch on both ends. They can be used on either side with either end against the panel.

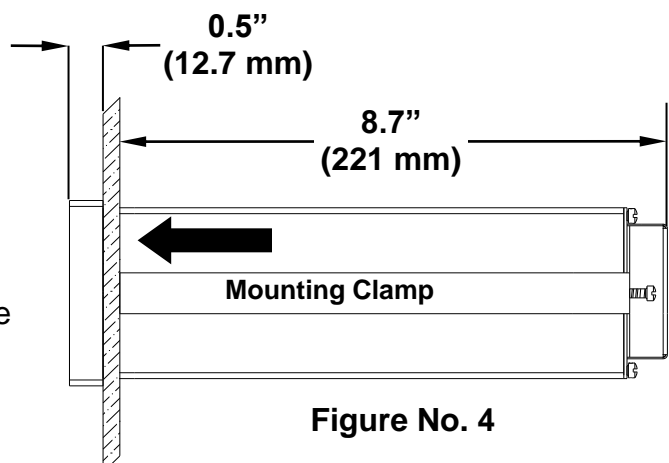

Figure No. 4

7. Install the 2 screws removed in step 2 and finger tighten.

8. While supporting the weight of the indicator (to insure the bezel is flush against the panel), tighten the 2 screws to secure the indicator to the panel. See Figure No. 4.

INSTALLATION, CONT.

Load Cell Connection



WARNING! Disconnect any external load cell power supply before connecting load cells to the indicator. Failure to do so will result in permanent damage to the indicator.

1. Remove the 2 screws securing the calibration switch access cover on the rear panel and remove the cover to expose the load cell connector. See Figure No. 5.
2. The LOAD CELL wires are to be connected to the P1 terminal block on the rear panel of the indicator. Refer to Figure No. 6 for the location of P1.
3. Remove 2" of the outer insulation jacket then remove 1/4" of insulation from each of the 4 wires and shield (without sense leads) or 6 wires and shield with sense leads.
4. Connect each of the wires to terminal block P1 referring to the labels on the rear panel and the P1 detail view for terminal connections.
5. Loosen the screws in the terminal block, then slip the wire into the terminal opening and tighten the screw to lock the wire in place. Repeat the procedure until all wires are in place.
6. Replace the calibration switch access cover on the rear panel and secure using the 2 screws removed in step 1.

NOTE: If the sense leads are NOT used, you must install plug-in jumpers at J4 and J5 on the main PC board. See Figure No. 7 for location of the jumpers. These jumpers attach the sense leads to the excitation leads. If sense leads ARE used (as in motor truck scales), these plug-in jumpers should be positioned on one plug-in pin only or removed and stored for later use.

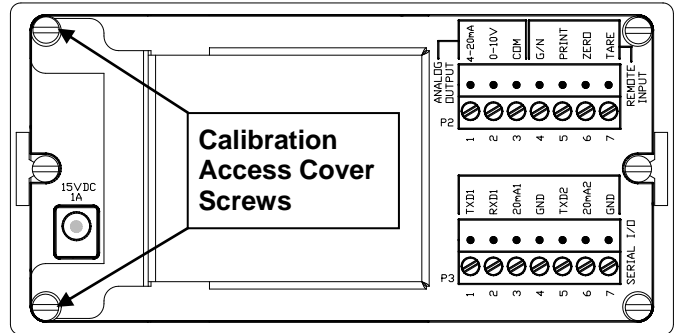

Figure No. 5

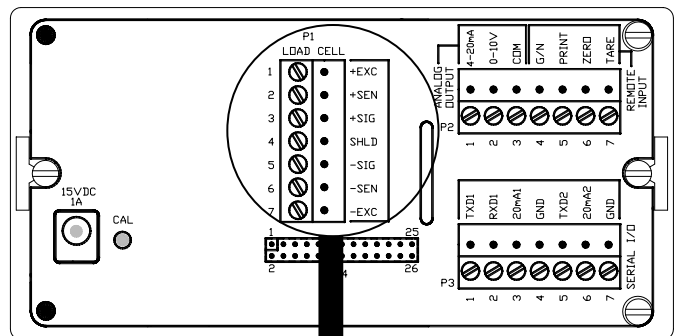
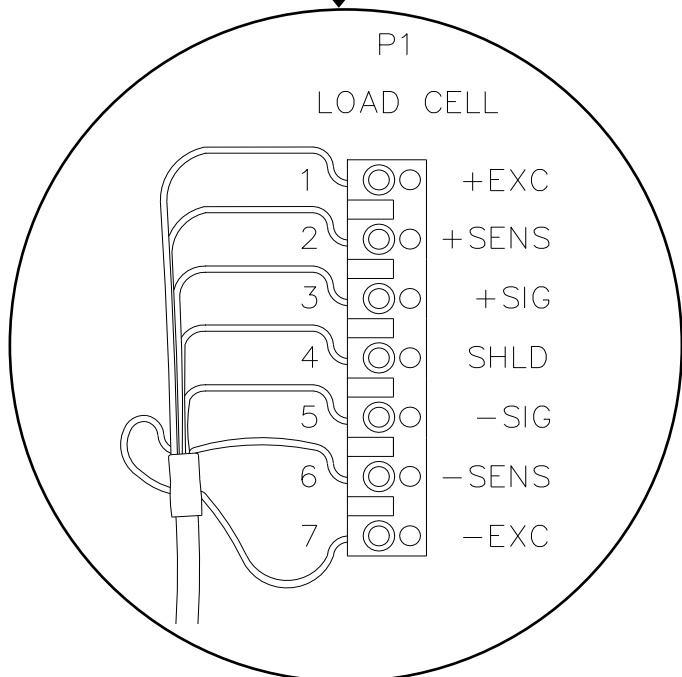

Figure No. 6



P1 Detail View

LOAD CELL CONNECTOR P1

PIN NO.	Function	PIN NO.	Function
1	+ EXCITATION	5	- SIGNAL
2	+ SENSE	6	- SENSE
3	+ SIGNAL	7	- EXCITATION
4	SHIELD		

INSTALLATION, CONT.

Load Cell Connections With Over 30 Feet Of Cable

For installations with over 30 feet of cable between the indicator and the load cells, sense wires should be used. The sense wires must be connected between the +SENS, -SENS terminals on the indicator and the +EXCITATION, -EXCITATION wires of the load cells or the +SENS, -SENS terminals of the load cell trim board or the section seal trim board. For the indicator to use the sense wires, the +SENS jumper J4 and the -SENS jumper J5 must be open (see Figure No. 9).

Serial I/O Cable Installation

The 200 indicator may be connected to a printer to record weight and associated data or it may be connected to a remote display or even to a computer for transmission of weight data. The weight data may be transmitted on demand (pressing the **PRINT** key or on receipt of a command from the computer). Refer to the Setup, SIO Serial I/O section of this manual.

1. The SERIAL I/O cable is connected to the P3 terminal block on the rear panel of the indicator. Refer to Figure No. 7 for the location of P3.
2. Remove 2" of the outer insulation jacket then remove 1/4" of insulation from each of the wires.
3. Connect each of the wires to terminal block P3 referring to the labels on the rear panel and the P3 detail view for terminal connections for terminal connections.
4. Loosen the screws in the terminal block, then slip the wire into the terminal opening and tighten the screw to lock the wire in place. Repeat the procedure until all wires are in place.

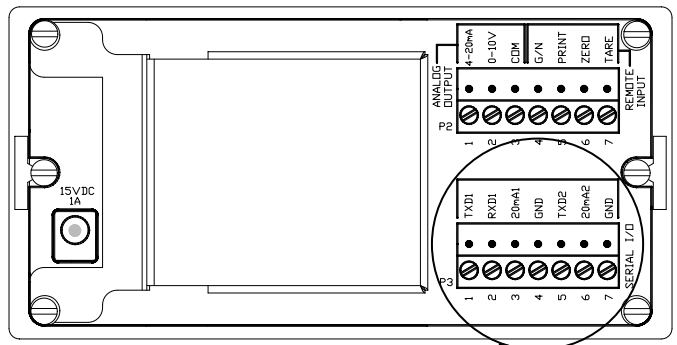
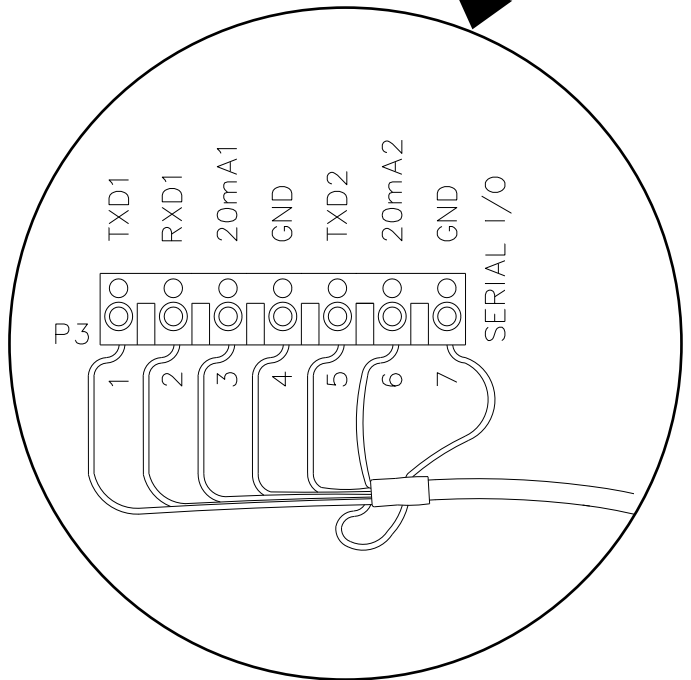

Figure No. 7



P3 Detail View

BI-DIRECTIONAL SERIAL INTERFACE

PIN NO.	Function
1	TXD 1 - RS232
2	RXD 1 - RS232
3	TXD 1 – 20 mA Active
4	GROUND

SERIAL OUTPUT

PIN NO.	Function
5	TXD 2 - RS232
6	TXD 2 – 20 mA Active
7	GROUND

INSTALLATION, CONT.

Optically Isolated Remote Inputs

Included with the I/O are 4 programmable inputs that may be used to remotely (up to 100 feet) initiate various functions within the indicator. These inputs are accessed via a terminal block (P2) on the rear panel of the indicator. See Figure No. 8.

1. The REMOTE INPUT wires are connected to the P2 terminal block on the rear panel of the indicator. Refer to Figure No. 8 for the location of P2.
2. Remove 2" of the outer insulation jacket then remove 1/4" of insulation from each wire.
3. Connect each of the wires to terminal block P2 referring to the labels on the rear panel and the P2 detail view for terminal connections.
4. Loosen the screws in the terminal block, then slip the wire into the terminal opening and tighten the screw to lock the wire in place. Repeat the procedure until all wires are in place.

NOTE: Remember that the input must be momentarily connected to one of the GND terminals on P3 to initiate the function.

Optional Analog Output (200-A Only)

The optional Analog Output Option DAC (Digital to Analog Converter) board consists of both a 0 to 10 volt and 4 to 20 mA analog output. Refer to the 2XX-DAC Digital to analog Converter Analog Output manual (8200-M350-O1) for installation and setup of the DAC board.

1. The ANALOG OUTPUT wires are connected to the P2 terminal block on the rear panel of the indicator. Refer to Figure No. 8 for the location of P2.
2. Remove 2" of the outer insulation jacket then remove 1/4" of insulation from each wire.
3. Connect each of the wires to terminal block P2 referring to the labels on the rear panel and the P2 detail view for terminal connections.
4. Loosen the screws in the terminal block, then slip the wire into the terminal opening and tighten the screw to lock the wire in place. Repeat the procedure until all wires are in place.

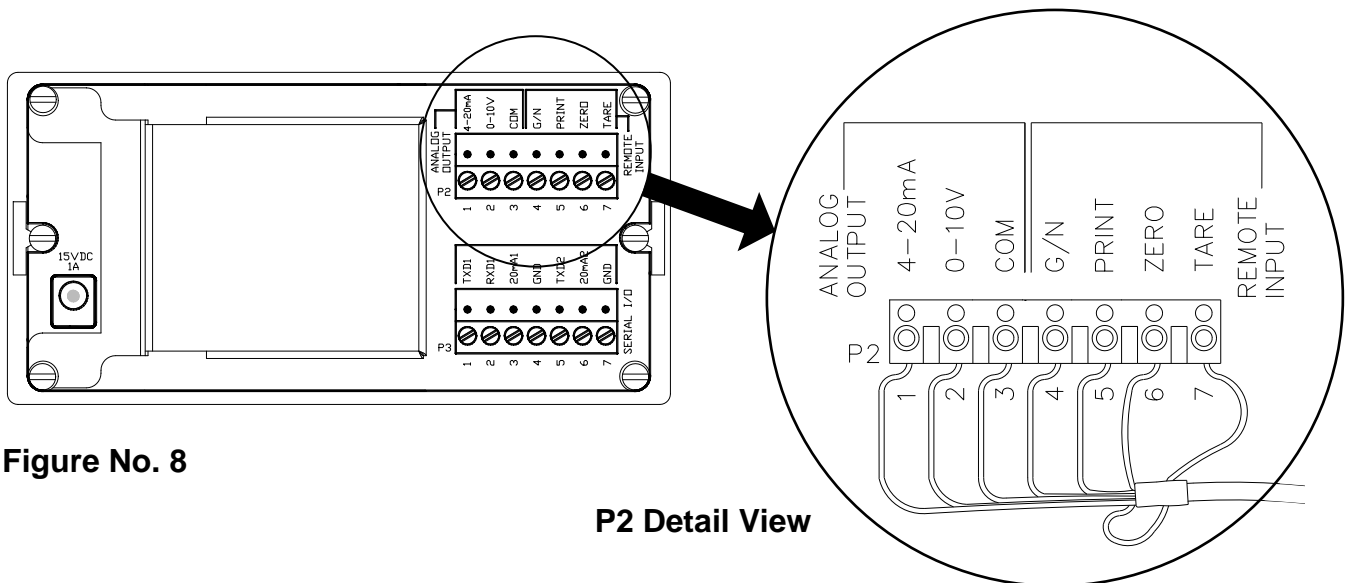

Figure No. 8

P2 Detail View

ANALOG OUTPUT (200-A Only)	
PIN NO.	Function
1	4-20mA OUTPUT
2	0-10V OUTPUT
3	COMMON

REMOTE INPUT	
PIN NO.	Function
4	GROSS / NET
5	PRINT
6	ZERO
7	TARE

INSTALLATION, CONT.

Main PCB

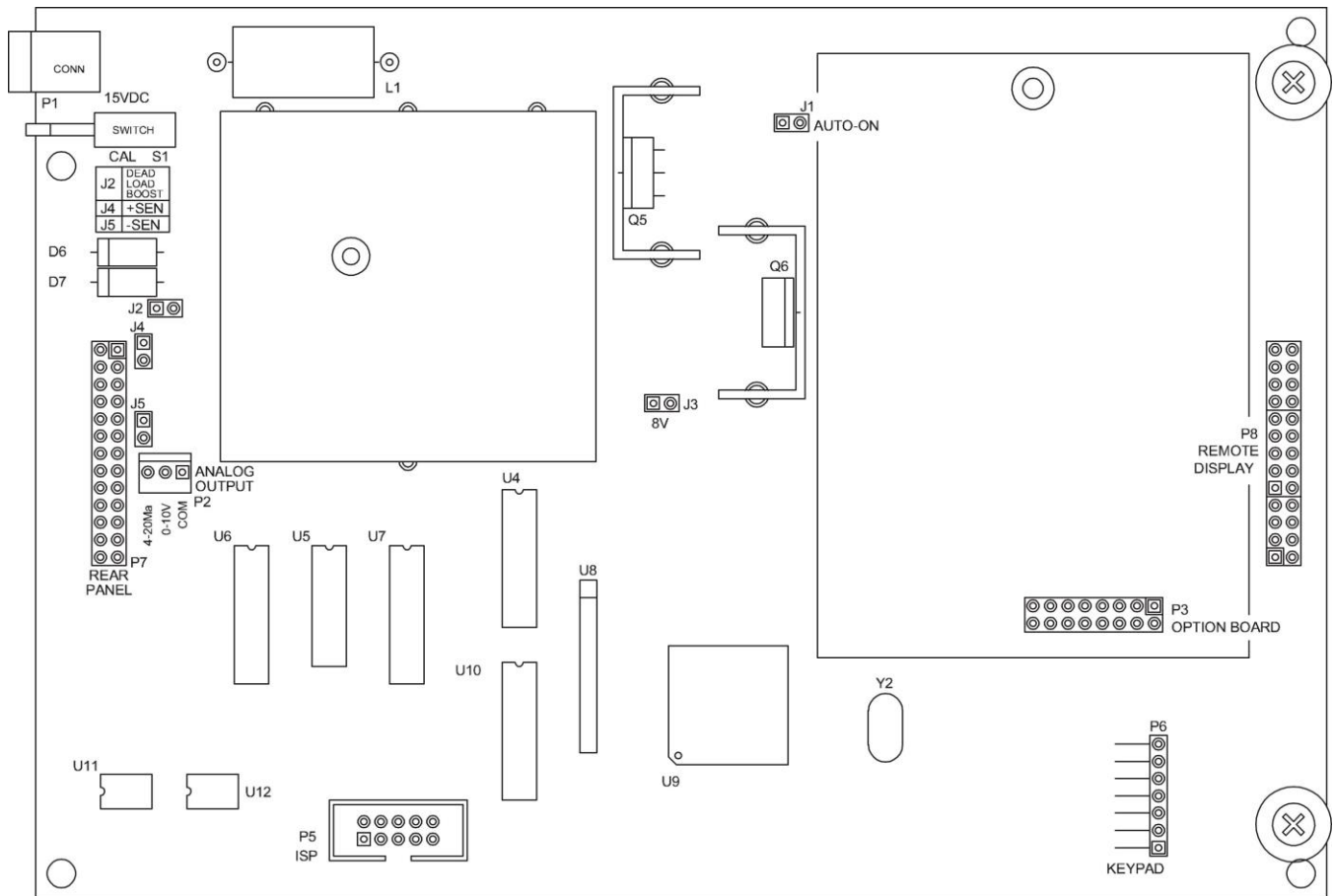

Figure No. 9

Main PCB Jumpers

J1 - AUTO-ON JUMPER

The AUTO-ON jumper J1, when connected, will cause the indicator to power on automatically whenever power is applied to the power input connector. If power is lost momentarily and then reapplied, the indicator will turn on without pressing the **ON** key.

J2 - DEAD LOAD BOOST JUMPER

For very low dead loads (less than 10% of the combined load cell capacity) connect the dead load boost jumper J2 on the printed circuit board.

J3 - 8V EXCITATION JUMPER

The 8V EXCITATION jumper J3, when connected, sets the load cell excitation voltage to 8V for operation with a 12 VDC battery. To operate from a 12 VDC battery, the load cell excitation voltage **MUST** be set to 8 VDC (J3 *closed*). Battery operation with the load cell excitation voltage set to 12V will result in an unstable weight display.

J4 AND J5 - SENSE JUMPERS

If the sense leads are **NOT** used, you must install plug-in jumpers at J4 and J5 adjacent to the terminal block. These jumpers attach the sense leads to the excitation leads. If sense leads **ARE** used (as in motor truck scales), these plug-in jumpers should be positioned on one plug-in pin only or removed and stored for later use.

KEYPAD FUNCTIONS

The Model 200 Weight Indicator is equipped with a 7-key keypad. The keypad is used to enter commands and data into the indicator. This section describes each key along with its normal function. It is helpful to refer to the actual indicator while reading this section.

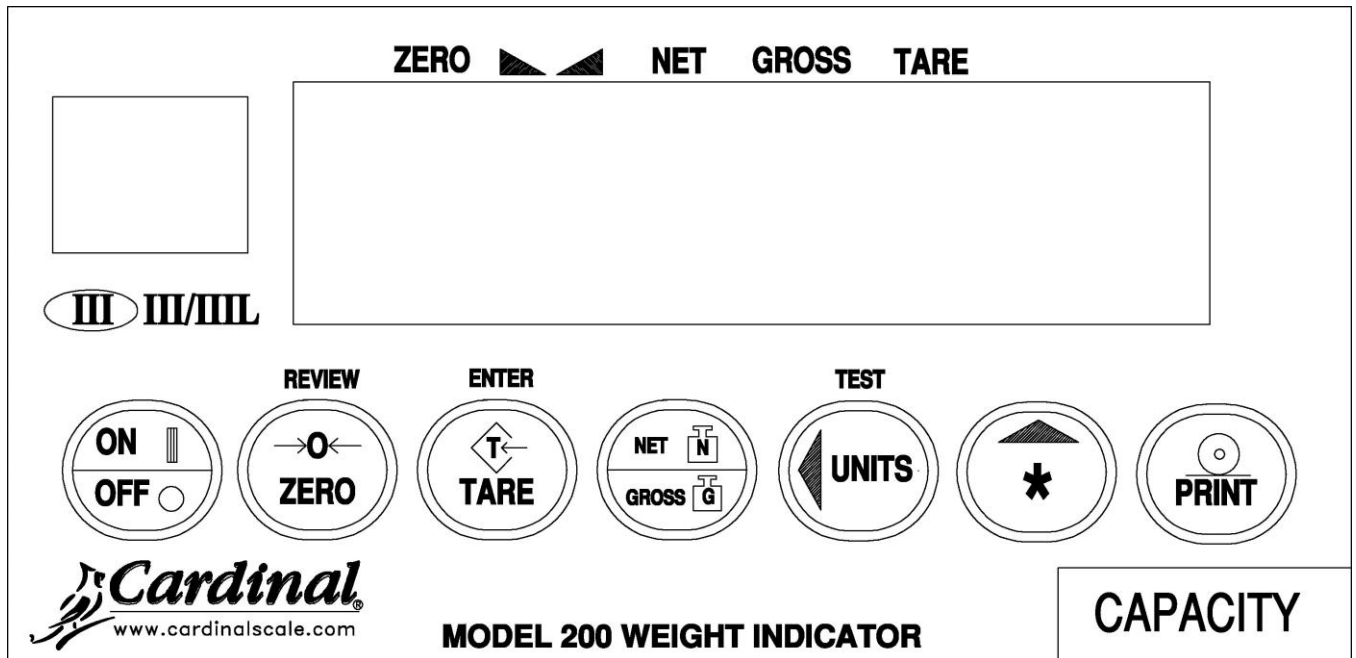

Figure No. 10



DO NOT operate the keypad with pointed objects (pencils, pens, etc). Damage to keypad resulting from this practice is **NOT** covered under warranty.

ON/OFF KEY

This key performs two functions. Pressing it when the indicator is off will apply power to the indicator. If the indicator is already on, pressing this key will turn the indicator off.

ZERO KEY/REVIEW

Pressing this key will cause an immediate zeroing of the weight display up to the selected limit of 4% or 100% of the scale's capacity. This selection is made during the setup and calibration of the indicator. Note the indicator will not respond to this command unless the weight display is stable.

Pressing the **ASTERISK** key before the **ZERO KEY/REVIEW** key will enter the Review mode of Setup and Calibration. Refer to the Setup Review section of this manual.

TARE/ENTER

Pressing the **TARE** key alone will store the current gross weight as the new tare weight and the weight display will change to the net weight display mode (Net annunciator will turn on).

Pressing the **ASTERISK** key before the **TARE/ENTER** key serves two purposes. First, when reviewing setup parameters, pressing the **TARE/ENTER** key will display the current setting of the parameter. Second, the **TARE/ENTER** key is used to signal completion of the entry of data and causes the indicator to process the data entered.

NET/GROSS KEY

This key is used to toggle between the Net and Gross weight modes. The selected mode is indicated by turning on the appropriate annunciator on the display. Note that if no valid tare weight has been entered, pressing this key will cause a momentary "not Tare" display error and the indicator will remain in the Gross weight mode.

KEYPAD FUNCTIONS, CONT.

UNITS / ◀ LEFT ARROW KEY/TEST

This key is used for several functions. In normal operation, this key is used to select the units in which the weight is to be displayed. The available units of measure ("unit1" and "unit2") are selected in setup. The available units include tons, pounds only, pound-ounces, ounces only, Tonnes (metric tons), kilograms, and grams. Note that not all combinations are supported.

During setup, this key is used to advance the cursor left to the next position when inputting setup parameters.

Pressing the **ASTERISK** key before the **UNITS/LEFT ARROW KEY/TEST** key will enter the Test mode. Refer to the description of the **ASTERISK** key below for details.

ASTERISK / ▲ UP ARROW KEY

This key is used for several functions. During setup, when a setup parameter (not a parameter value) is displayed, pressing this key will "backup" to the previous prompt. Also during setup, when a parameter value is displayed, pressing this key will "toggle" between the different available values for the setup parameter. In normal operation, this key is used in conjunction with the other keys on the keypad to access additional indicator features. These features and their associated key combinations are as follows:

ASTERISK, ZERO KEY

This combination will enter the Review mode of Setup and Calibration. Refer to Setup Review section of this manual for details.

ASTERISK, TARE KEY

This combination will display the current tare weight for three (3) seconds.

ASTERISK, NET/GROSS KEY

This combination will display the Net accumulator.

ASTERISK, NET/GROSS KEY, PRINT KEY

This combination will print the Net accumulator.

ASTERISK, NET/GROSS KEY, ZERO KEY

This combination will zero (clear) the Net accumulator.

ASTERISK, NET/GROSS KEY, NET/GROSS KEY

This combination will display the Gross accumulator.

ASTERISK, NET/GROSS KEY, NET/GROSS KEY, PRINT KEY

This combination will print the Gross accumulator.

ASTERISK, NET/GROSS KEY, NET/GROSS KEY, ZERO KEY

This combination will zero (clear) the Gross accumulator.

ASTERISK, UNITS KEY

This combination will enter the Test mode. The Test mode is used to conduct a test of all display elements. The test consists of 5 cycles, each lasting about one second:

1. All horizontal segments will turn on (no annunciators).
2. All vertical segments and decimal points will turn on (no annunciators).
3. All annunciators will turn on.
4. All display elements off.
5. The model number (200) and the software version X.X.
6. The calibration numbers (C1 to C4).

KEYPAD FUNCTIONS, CONT.

ASTERISK, PRINT KEY

This combination is used to *change* the selected print ticket format. Pressing the **ASTERISK** then the **PRINT** key will display a prompt "P r t =". Press the **TARE/ENTER** key to show the current value. If the setting displayed is acceptable, press the **TARE/ENTER** key again to save it. Otherwise, press the **ASTERISK/UP ARROW** key to "toggle" between the different available values, then press the **TARE/ENTER** key to save it. Allowable values are:

0 = print tab settings 1 = visual ticket format 1 2 = visual ticket format 2



NOTE: When a print format is selected, it will remain active until changed by the operator.

PRINT KEY

Pressing this key will add the displayed gross or net weight to the associated accumulator and initiate the transmission of weight and other data depending on the Print Tab Settings (see example) via the selected printer output port (see Port= under Print menu) unless the continuous data feature of this port was enabled during setup and calibration. Note that the indicator will not respond to this command unless the weight display is stable. If displaying gross weight, the only weight printed is gross weight. If displaying net weight, the gross, tare, and net weights will print.

The 200 includes support for visual tickets. Visual tickets are designed by the PC based programs Visual Print or n Control, then downloaded to the indicator. The 200 allows two programmable formats in addition to the standard print tab settings format.

Print formats are selected by using the **ASTERISK** and **PRINT** keys in combination (refer to the previous section for details). **NOTE:** When the **PRINT** key is pressed the indicator looks for the selected format. If no visual ticket is found it reverts to the print tab settings.

#2
100.00 lb G
20.00 lb T
80.00 lb N
0.00 lb GROSS ACCUM
272.00 lb NET ACCUM

TICKET EXAMPLE

ANNUNCIATORS

Annunciators are turned on to indicate that the display is in the mode corresponding to the annunciator label or that the status indicated by the label is active. The annunciators flash on and off to indicate that the indicator is waiting for an input from the keypad for the mode indicated by the flashing annunciator. Refer to Figure No. 10 for location of the annunciators.

ZERO

This annunciator is turned on to indicate that the weight displayed is within +/- 1/4 division of the center of zero.

▲▲ (STABLE)

This annunciator is turned on when the weight display is stable. When off, it means that the change in successive weight samples is greater than the motion limits selected during setup.

NET

This annunciator is turned on to show that the displayed weight is the net weight (gross weight less tare weight).

GROSS

This annunciator is turned on to show that gross weight is displayed. Gross weight will be displayed when no tare weight is stored.

TARE

This annunciator is turned on to show that the displayed weight is the tare weight.

T

This annunciator is located to the right of the weight display and is turned on to show that the displayed weight unit is tons.

g

This annunciator is located to the right of the weight display and is used to indicate that the displayed unit of weight measurement is grams.

lb

This annunciator is located to the left of the weight display and is turned on to show that the displayed weight unit is pounds.

oz

This annunciator is located to the right of the weight display and is turned on to show that the displayed weight unit is ounces.

kg

This annunciator is located to the left of the weight display and is used to indicate that the displayed unit of weight measurement is kilograms.

t

This annunciator is located to the right of the weight display and is used to indicate that the displayed unit of weight measurement is Tonnes (metric tons).

SETUP AND CALIBRATION

Your Model 200 Weight Indicator has been thoroughly tested and calibrated before being shipped to you. If you received the indicator attached to a scale, calibration is not necessary. If the indicator is being connected to a scale for the first time or recalibration is necessary for other reasons, proceed as indicated.

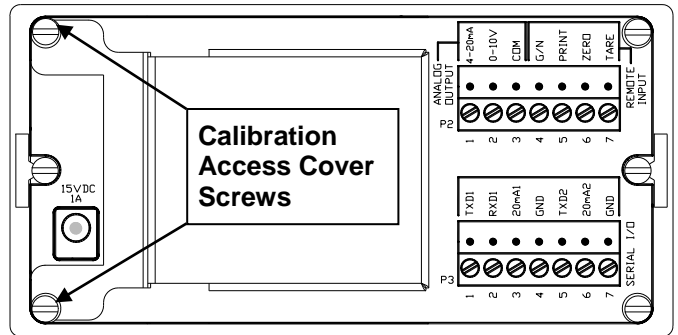

Figure No. 11

The calibration switch is located on the enclosure rear panel. You may gain access to this switch by removing the 2 screws securing the calibration switch access cover on the rear panel. Refer to Figure No. 11.

During setup and calibration it will be necessary to enter operational parameters using the indicator keypad.

- Pressing the **TARE/ENTER** key will cause the data entered or displayed to be retained and the indicator to advance to the next prompt.
- The functions of numeric keys are replaced by using the **UNITS/LEFT ARROW** and the **ASTERISK/UP ARROW** keys.
- The cursor location is identified by the blinking character and can be advanced to the next position (left) by pressing the **UNITS/LEFT ARROW** key.
- Pressing the **ASTERISK/UP ARROW** key will change the blinking character to the next value. Continue to press this key to toggle between the available values for the setup parameter.
- Pressing the **ASTERISK/UP ARROW** key when a setup parameter (not a parameter value) is displayed, will "backup" to the previous prompt.



DO NOT operate the keypad with pointed objects (pencils, pens, etc).
Damage to keypad resulting from this practice is **NOT** covered under warranty.

Enter Setup Mode

To enter the setup mode, with the indicator ON, insert a small screwdriver or other tool through the calibration switch access hole on the rear panel. Press and release the calibration switch. The menu *SEtUP* will be displayed. Continue to press and release the switch to rotate through the beginning point for entering the setup mode.

<i>SEtUP</i>	Setup Mode (starts at <i>USR</i> prompt)
<i>A-d</i>	Analog to Digital Filtering (starts at <i>dFLt=</i> prompt)
<i>CRl</i>	Calibration (starts at <i>CRl 1</i> prompt)
<i>SSt</i>	Setup Guardian Scale (starts at <i>tL oU</i> prompt)
<i>S iO</i>	Serial Input/Output (starts at <i>S iO</i> prompt)
<i>Pr int</i>	Print Tab Settings (starts at <i>Pr t</i> prompt)
<i>F SPAn</i>	Fine Span Adjustment
<i>Hi rES</i>	Display high-resolution weight mode
<i>LoCkOut</i>	Key lock out function
<i>oPt ion</i>	Option Card Configuration (only displayed when option card is installed)

If you press the **TARE/ENTER** key at the *SEtUP* prompt, you may proceed through to the next section (up to and including *F SPAn*) by pressing the **TARE/ENTER** key.

SETUP AND CALIBRATION, CONT.



IMPORTANT! Setup may be interrupted at any time. ALL data previously entered and finalized with the **TARE/ENTER** key will be retained in the non-volatile memory.

Pressing the calibration switch *at any prompt* will return you to the **SETUP** menu. To exit setup, press the **ASTERISK/UP ARROW** key with any of the above menu selections displayed or cycle power at any time (press the **ON/OFF** key twice).

NOTE: With the exception of the **SETUP** prompt, the prompts displayed for each section are different if you push the calibration switch instead of pressing the **TARE/ENTER** key to proceed through the section.

For example, if you press the calibration switch with the **SETUP** displayed, the next prompt displayed will be **R-d**.

If you step through the setup prompts by pressing the **TARE/ENTER** key, the next prompt displayed will be **R-d²**.

In addition, at a prompt with the **d²** displayed, you must press the **TARE/ENTER** key, the **1/YES** key then the **TARE/ENTER** key again to proceed with that section.

To skip the section and advance you to the next menu selection, press the **TARE/ENTER** key twice.

SETUP

USR= (Domestic or International)

With **SETUP** displayed, press the **TARE/ENTER** key. The display will change to **USR=**. Press the **TARE/ENTER** key to show the current value. If the setting displayed is acceptable, press the **TARE/ENTER** key again to save it. Otherwise, use the **ASTERISK/UP ARROW** key to toggle to a new setting and then press the **TARE/ENTER** key to save it.

USR=1 (Domestic)

ErL = no
CRP + 4% to OC

USR=0 (International)

ErL = yes
CRP + 9 grads to OC
PT printed with tare
Lamp test on power up

LFT= (Legal For Trade)

Press the **TARE/ENTER** key to show the current value. If the setting displayed is acceptable, press the **TARE/ENTER** key again to save it. Otherwise, use the **ASTERISK/UP ARROW** key to toggle to a new setting and then press the **TARE/ENTER** key to save it.

LFT=1

Interval Settings (Int=) allowed
are: 1, 2, 5, 10, 20, 50

LFT=0

Interval Setting (Int=) is
selectable from 1 to 99.

NOTE: When both **LFT=1** and **USR=1**, the followings results occur:

Scale must have between 100 and 10,000 divisions

ErR = .5 or 0 to 3

Inhibit serial data during input

ErL = no

CRP + 4% to OC

NOTE: When **LFT=1** and **USR=0**, the followings results occur:

UnS = 1

ErL = yes

CRP + 9 grads to OC

PT printed with tare

Lamp test on power up

SETUP AND CALIBRATION, CONT.

Unit 1: (Weighing Unit 1)

Press the **TARE/ENTER** key to show the current value. If the setting displayed is acceptable, press the **TARE/ENTER** key again to save it. Otherwise, use the **ASTERISK/UP ARROW** key to toggle to a new setting and then press the **TARE/ENTER** key to save it. Allowable values are:

0 = none	4 = oz (ounces)
1 = tn (tons)	5 = kg (kilograms)
2 = g (grams)	6 = tonnes (metric tons)
3 = lb (pounds)	7 = lb/oz (pounds/ounces)

Interval: (Interval Setting)

Press the **TARE/ENTER** key to show the current value.

If **LFt = 1** (Legal For Trade = YES), use the **ASTERISK/UP ARROW** key to toggle to a new setting and then press the **TARE/ENTER** key to save it. Allowable values are: 1, 2, 5, 10, 20 or 50.

If **LFt = 0** (Legal For Trade = NO), use the **ASTERISK/UP ARROW** key to toggle to a new setting and then press the **TARE/ENTER** key to save it. Allowable values are: 1 through 99.

In either case, if the setting displayed is acceptable, press the **TARE/ENTER** key again it.

dPP: (Decimal Point Setting)

Press the **TARE/ENTER** key to show the current value. If the setting displayed is acceptable, press the **TARE/ENTER** key again to save it. Otherwise, use the **ASTERISK/UP ARROW** key to toggle to a new setting and then press the **TARE/ENTER** key to save it. Allowable values are: 0, 1, 2 or 3.

0 = XXXXXX	2 = XXXX.XX
1 = XXXXX.X	3 = XXX.XXX

[RP: (Capacity)

Press the **TARE/ENTER** key to show the current value. If the setting displayed is acceptable, press the **TARE/ENTER** key again to save it. Otherwise, use the **ASTERISK/UP ARROW** key to toggle to a new setting and then press the **TARE/ENTER** key to save it. Allowable values are: 1 through 999,999. **NOTE:** Capacity cannot exceed 999,999.

Unit 2: (Weighing Unit 2)

Press the **TARE/ENTER** key to show the current value. If the setting displayed is acceptable, press the **TARE/ENTER** key again to save it. Otherwise, use the **ASTERISK/UP ARROW** key to toggle to a new setting and then press the **TARE/ENTER** key to save it. Allowable values are:

0 = none	4 = oz (ounces)
1 = tn (tons)	5 = kg (kilograms)
2 = g (grams)	6 = tonnes (metric tons)
3 = lb (pounds)	7 = lb/oz (pounds/ounces)

NOTE: The selection for **Unit 2** cannot be the same as **Unit 1**. In addition, dependent upon the selection for **Unit 1** and the interval and decimal point settings, not all unit combinations are available.

SETUP AND CALIBRATION, CONT.

t r R = (Zero Tracking Range)

Press the **TARE/ENTER** key to show the current value assigned to the Automatic Zero Tracking Range. This is the value in scale divisions that will be automatically zeroed off. If the setting displayed is acceptable, press the **TARE/ENTER** key again to save it. Otherwise, use the **ASTERISK/UP ARROW** key to toggle to a new setting and then press the **TARE/ENTER** key to save it. Allowable values are: 0 (disables Zero Tracking), .5, or 1 through 9.

t r L = (4% Zero Range)

Press the **TARE/ENTER** key to show the current value. If the setting displayed is acceptable, press the **TARE/ENTER** key again to save it. Otherwise, use the **ASTERISK/UP ARROW** key to toggle to a new setting and then press the **TARE/ENTER** key to save it.

t r L = 1 (Yes)

4% of scale capacity

t r L = 0 (No)

Full capacity (no limit)

P U O = (Power-Up Zero Feature)

Press the **TARE/ENTER** key to show the current value. If the setting displayed is acceptable, press the **TARE/ENTER** key again to save it. Otherwise, use the **ASTERISK/UP ARROW** key to toggle to a new setting and then press the **TARE/ENTER** key to save it.

P U O = 1 (Yes)

Automatic Re-Zero on Power-Up

P U O = 0 (No)

No Re-Zero on Power-Up

S L E E P = (Sleep Mode Feature)

The Sleep Mode feature conserves battery power when the indicator remains unused for a selected period of time. With the feature enabled, the load cell excitation will be reduced and the display will be blank.

Press the **TARE/ENTER** key to show the current status of this feature. If a number other than 0 is shown, this feature is selected and the number shown corresponds to the number of minutes of a stable zero weight reading before the indicator enters the sleep mode.

If the setting displayed is acceptable, press the **TARE/ENTER** key again to save it. Otherwise, use the **ASTERISK/UP ARROW** key to toggle to a new setting and then press the **TARE/ENTER** key to store the new setting. Allowable values are: 0 through 10. Note that selecting 0 disables this feature.

A O F F = (Auto Shutoff)

The Automatic Shutoff feature will automatically turn the indicator off (when it is not in use) after a predetermined period of inactivity to prolong battery life. To turn the indicator back on you must press the **ON / OFF** key.

Press the **TARE/ENTER** key to show the current status for this feature. A number other than 0 indicates that the auto shutoff feature is enabled and the displayed number corresponds to the number of minutes of stable weight displayed before the indicator is turned off automatically.

If the setting displayed is acceptable, press the **TARE/ENTER** key again to save it. Otherwise, use the **ASTERISK/UP ARROW** key to toggle to a new setting (0 to 10) and then press the **TARE/ENTER** key to store the new setting. Allowable values are: 0 through 10. Note that selecting 0 disables this feature.

SETUP AND CALIBRATION, CONT.

`CLTAR =` (Clear Tare)

The Clear Tare feature allows the indicator to clear the Stored Tare weight when the Net weight goes below a value greater than 1/2 the stored tare weight or goes below zero (a negative net weight after display of a positive net weight). With this feature enabled, the operator must re-set the tare after completion of a transaction when the load (container plus item) is removed from the scale.

Press the **TARE/ENTER** key to show the current value. If the setting displayed is acceptable, press the **TARE/ENTER** key again to save it. Otherwise, use the **ASTERISK/UP ARROW** key to toggle to a new setting and then press the **TARE/ENTER** key to save it.

`CLTAR = 1` (Yes)

Automatically clears Stored Tare when Net weight goes below zero

`CLTAR = 0` (No)

Stored Tare is not cleared when Net weight goes below zero

SETUP AND CALIBRATION, CONT.

$R - d (R - d^2)$ - Analog to Digital Filtering

$SErSCL$ - (REMOTE INDICATOR SETUP)*

If the indicator is to function as a remote indicator, press the **ASTERISK/UP ARROW** key to select **YES** at the $SErSCL$ prompt. If not then press the **TARE/ENTER** key at the prompt.



IMPORTANT! If the 200 indicator is to be used as the LOCAL and as the REMOTE, then both indicators **MUST** have Rev 2.6.3 or greater software installed.

If a combination of a 200 and a 225 indicator are to be used in a LOCAL/REMOTE configuration, then the remote 200 indicator **MUST** have Rev 2.6.1 or greater software installed, and the 225 indicator **MUST** have Rev 1.0.K or greater software installed.

LrP = (Local/Remote Port)

NOTE: This will only be displayed if $SErSCL$ was set to **YES**

Press the **TARE/ENTER** key to show the current value. If the setting displayed is acceptable, press the **TARE/ENTER** key again to save it. Otherwise, use the **ASTERISK/UP ARROW** key to toggle to a new setting and then press the **TARE/ENTER** key to save it. Allowable values are: **1** for port 1 or **3** for the optional 2xx-RS232 card (if installed).

* Refer to the **LOCAL/REMOTE SETUP** section of this manual for more information and the interconnect wiring diagram.

$dFLt$ = (Digital Filtering)

With $R - d (R - d^2)$ displayed, press the **TARE/ENTER** key. The display will change to $dFLt$ =. Press the **TARE/ENTER** key to show the current value. If the setting displayed is acceptable, press the **TARE/ENTER** key to save it. Otherwise, use the **ASTERISK/UP ARROW** key to toggle to a new setting and then press the **TARE/ENTER** key to save it. Allowable values are: 0, 1, 2 or 3. Note, that if you select 3 (Custom Filtering) two additional prompts will be displayed.

$dFLt$ =

- | | |
|---|--------------------------------------|
| 0 | Disabled – NO Filtering |
| 1 | MINIMAL FILTERING (sample rate = 2) |
| 2 | MODERATE FILTERING (sample rate = 1) |
| 3 | CUSTOM FILTERING |

NOTE: The prompts, F = (Filter Level), h = (High Frequency Filter Value) and b = (Break Range) will only be displayed if you selected 3 (Custom Filtering) for the $dFLt$ = (Digital Filtering) prompt.

F = (Filter Level)

Press the **TARE/ENTER** key to show the current setting for the filter level. The filter level is a number from 1 to 99 that corresponds to the level of filtering with 99 being the greatest filtering and 1 the least. To accept the value displayed, press the **TARE/ENTER** key, otherwise, use the **ASTERISK/UP ARROW** key to toggle to a new setting and then press the **TARE/ENTER** key to save it.

b = (Break Range)

Press the **TARE/ENTER** key to show the current setting for the break range. The break range is a number from 1 to 255 that corresponds to the number of division change to break out of the filtering. Press the **TARE/ENTER** key to keep the displayed value or use the **ASTERISK/UP ARROW** key to toggle to a new setting and then press the **TARE/ENTER** key to save it. Note that selecting 0 disables this feature.

SETUP AND CALIBRATION, CONT.

h = (High Frequency Filter Value)

Press the **TARE/ENTER** key to show the current setting for the high frequency filter level. The filter level is a number from 0 to 99 that corresponds to the level of filtering with 99 being the greatest filtering and 1 the least.

Press the **TARE/ENTER** key to keep the displayed value or use the **ASTERISK/UP ARROW** key to toggle to a new setting and then press the **TARE/ENTER** key to save it. Note that selecting 0 disables this feature.

Sr = (Sample Rate)

Press the **TARE/ENTER** key to show the current setting for the sample rate. The value displayed is the sample rate in samples per second. Press the **TARE/ENTER** key to save the displayed value or use the **ASTERISK/UP ARROW** key to toggle to a new value (1 to 100) and then press the **TARE/ENTER** key to save it.

UnS = (Motion Range)

Press the **TARE/ENTER** key to view the current setting for the range of motion detection. If the displayed value is acceptable, press the **TARE/ENTER** key to save it. Otherwise, use the **ASTERISK/UP ARROW** key to toggle to a new range (the number of divisions of change permitted before indicating unstable) and then press the **TARE/ENTER** key to save the new setting. Allowable range values are: 0 through 99 divisions.

SC = (Stable Count)

Press the **TARE/ENTER** key to view the current setting for the number of consecutive stable weight readings before indicating stable weight. This helps filter weight readings for stability when trying to capture stable weight. If the displayed value is acceptable, press the **TARE/ENTER** key to save it. Otherwise, use the **ASTERISK/UP ARROW** key to toggle to a new value and press the **TARE/ENTER** key to save the new setting. Allowable values for the stable count are: 3 through 255.

SETUP AND CALIBRATION, CONT.

FILTER SETTING RECOMMENDATIONS

Non Critical Sample Rate

If the sample rate is not critical, as in static weighing, set $dFLt =$ to "0" (no filtering), $dFLt =$ "1" ($F=6, b=12, Sr = 2/Sec$), or $dFLt =$ "2" ($F=6, b=8, Sr = 1/Sec$).

Critical Sample Rate

If the sample rate is critical, as in a filling operation, use the Custom Filtering (set $dFLt =$ to "3").

1. $Sr =$ SAMPLE RATE (1 to 50 samples/second) determination:

Set the sample rate as close as possible to produce a display graduation change for every graduation of material added to the scale.

$$\frac{\text{Material Flow Rate (lbs/second)}}{\text{Resolution}} =$$

EXAMPLE: $\frac{100\text{lbs/sec}}{10\text{lbs}} = 10\text{s/s} = Sr$

2. $b =$ BREAK RANGE (1 to 255 graduations) determination:

Turn the filtering off by setting the $dFLt =$ setting to "0". Operate the system as it will be normally used and, by observation, determine the number of grads of instability that needs to be filtered out. Set the break range ($b =$) to that value.

$$\frac{\text{Weight Change}}{\text{Graduation Value}} = b$$

EXAMPLE: 20,000 x 10lb capacity scale with 800lb variation in the weight display.

$$\frac{800}{10} = b = 80$$

3. $F =$ FILTER SETTING (1 to 99) determination: Set to desired results.
4. If stability is unacceptable with any setting of $F =$, reduce the sample rate and/or increase the break range, $b =$ setting for increased filtering.

SETUP AND CALIBRATION, CONT.

CAL (CAL2) - Calibration

With **CAL (CAL2)** displayed, press the **TARE/ENTER** key. The display will change to show the current setting **00**. If calibration is desired, press the **ASTERISK/UP ARROW** key (display will change to **YES**) and then the **TARE/ENTER** key to continue to the **CAL 1=** setting, otherwise press the **TARE/ENTER** key to advance to the **5 00** menu.

CALIBRATION MODES

The 200 indicator has five modes that can be used to perform calibration. Three of the modes require a test load or test weights, one requires the scale to be empty (and at zero) and the last uses the calibration “C” numbers from a previous calibration. The modes are as follows:

1. Dual-Point with Zero (First Zero)

This is a standard calibration method requiring one weight, an empty scale and has one conversion factor. This method uses two calibration points (**CAL 1=** and **CAL 2=**) to establish a zero (no load) calibration value and to span the indicator. The two points correspond to zero weight and the test load or test weight and can be applied in any order. This method should be used for first-time calibration and complete recalibration.

2. Dual-Point without Zero (False Zero)

This calibration method requires one test weight and establishes a new conversion factor only. It is used to establish a false (temporary zero) zero without affecting the zero calibration value stored during the last calibration. This is particularly useful in tank weighing applications, where it may be impractical or impossible to completely empty the tank. This method uses two calibration points, **CAL 1=** and **CAL 2=**. The value of the test weight is entered when **CAL 1=** is displayed and the **NET/GROSS** key is pressed when **CAL 2=** is displayed.

3. Single-Point for Span Only (Last Zero)

This calibration method requires one test weight and establishes a new conversion factor (span) without affecting the zero calibration value stored during the last calibration. This minimizes placing and removing test weights and is especially useful when checking high capacity scales. This method uses two calibration points, **CAL 1=** and **CAL 2=**. The value of the test weight is entered when **CAL 1=** is displayed and the **ZERO** key is pressed when **CAL 2=** is displayed.

4. Single-Point for Zero Only (Only Zero)

This calibration method requires no test weight, an empty scale and establishes a new zero without affecting the conversion factor (span). This is useful to regain the full range of zero limit when the dead load of the scale has changed. This would occur for example, if a guard rail has been added to the scale platform. This method uses two calibration points, **CAL 1=** and **CAL 2=**. The **TARE/ENTER** key is pressed when **CAL 1=** is displayed and the **ZERO** key is pressed when **CAL 2=** is displayed.

5. Calibration “C” Numbers

The calibration “C” numbers (**C 1**, **C 2**, **C 3** and **C 4**) are displayed only during the Test mode operation and are shown at the end of the test. Each number is displayed for approximately 4 seconds, allowing you to record them. These numbers correspond to the calibration setting of the indicator. The numbers may be up to three digits in length. By recording these numbers you will be able to return the indicator to its present calibration settings without using test weights simply by entering the “C” numbers. *Refer to the Calibration “C” Number section of this manual for instructions on viewing the “C” numbers.*

SETUP AND CALIBRATION, CONT.

Dual-Point with Zero (First Zero) Calibration



IMPORTANT! The functions of numeric keys are replaced by using the **UNITS/LEFT ARROW** and the **ASTERISK/UP ARROW** keys. The cursor location is identified by the blinking character and can be advanced to the left to the next position by pressing the **UNITS/LEFT ARROW** key. Pressing the **ASTERISK/UP ARROW** key will change the blinking character to the next value.

CAL 1= – First Calibration Weight

The display will show **CAL 1=0**. This is the first of two calibration weights. This weight could be ZERO (NO LOAD) or the TEST WEIGHTS / TEST LOAD.

- If the first calibration weight is to be ZERO (NO LOAD), press the **TARE/ENTER** key.
- If the first calibration weight is to be the TEST WEIGHTS / TEST LOAD, use the **UNITS/LEFT ARROW** and **ASTERISK/UP ARROW** keys to input the value of the calibrated test weights. **NOTE:** When entering values for **CAL 1=**, the digits start displaying on the right side of the display and proceed to the left. When large values are used (more than 3 digits), the **CAL 1=** prompt will automatically scroll off the left side of the display to show the additional digits on the right as they are entered.
- Place the weights on the scale platform, then press the **TARE/ENTER** key.
- Starting at the left and advancing right, a series of dashes will appear on the display. The dashes will stay on the display momentarily, then disappear, after which the display will show: **CAL 2=**.

CAL 2= - Second Calibration Weight

The display will show **CAL 2=0**. This is the second of two calibration weights. This weight could be ZERO (NO LOAD) or the TEST WEIGHTS / TEST LOAD.

- If the second calibration weight is to be ZERO (NO LOAD), press the **TARE/ENTER** key.
- If the second calibration weight is to be the TEST WEIGHTS / TEST LOAD, use the **UNITS/LEFT ARROW** and **ASTERISK/UP ARROW** keys to input the value of the calibrated test weights. **NOTE:** When entering values for **CAL 2=**, the digits start displaying on the right side of the display and proceed to the left. When large values are used (more than 3 digits), the **CAL 2=** prompt will automatically scroll off the left side of the display to show the additional digits on the right as they are entered.
- Place the weights on the scale platform, then press the **TARE/ENTER** key.
- Starting at the left and advancing right, a series of dashes will appear on the display. The dashes will stay on the display momentarily, then disappear, after which the display will show: **CAL 3=**.

CAL 3= - Last Calibration Weight

The display will show **CAL 3=0**. This weight is not used. Press the **TARE/ENTER** key to skip **CAL 3=** and advance to **5.00**.

SETUP AND CALIBRATION, CONT.

Dual-Point without Zero (False Zero) Calibration



IMPORTANT! The functions of numeric keys are replaced by using the **UNITS/LEFT ARROW** and the **ASTERISK/UP ARROW** keys. The cursor location is identified by the blinking character and can be advanced to the left to the next position by pressing the **UNITS/LEFT ARROW** key. Pressing the **ASTERISK/UP ARROW** key will change the blinking character to the next value.

CAL 1= – First Calibration Weight

The display will show **CAL 1=0**. This is the first of two calibration steps. This weight is the TEST WEIGHTS / TEST LOAD.

- Place the weights on the scale platform.
- Using the **UNITS/LEFT ARROW** and **ASTERISK/UP ARROW** keys, input the value of the calibrated test weights / test load, then press the **TARE/ENTER** key. **NOTE:** When entering values for **CAL 1=**, the digits start displaying on the right side of the display and proceed to the left. When large values are used (more than 3 digits), the **CAL 1=** prompt will automatically scroll off the left side of the display to show the additional digits on the right as they are entered.
- Starting at the left and advancing right, a series of dashes will appear on the display. The dashes will stay on the display momentarily, then disappear, after which the display will show: **CAL 2=**.

CAL 2= - Second Calibration Weight

The display will show **CAL 2=0**. This is the second of two calibration steps.

- Remove the weights on the scale platform, and then press the **NET/GROSS** key.
- Starting at the left and advancing right, a series of dashes will appear on the display. The dashes will stay on the display momentarily, then disappear, after which the display will show: **5 10²**.

Single-Point for Span Only (Last Zero) Calibration

CAL 1= – First Calibration Weight

The display will show **CAL 1=0**. This is the first of two calibration steps. This weight is the TEST WEIGHTS / TEST LOAD.

- Zero the scale, and then place the weights on the scale platform.
- Using the **UNITS/LEFT ARROW** and **ASTERISK/UP ARROW** keys, input the value of the calibrated test weights / test load, then press the **TARE/ENTER** key. **NOTE:** When entering values for **CAL 1=**, the digits start displaying on the right side of the display and proceed to the left. When large values are used (more than 3 digits), the **CAL 1=** prompt will automatically scroll off the left side of the display to show the additional digits on the right as they are entered.
- Starting at the left and advancing right, a series of dashes will appear on the display. The dashes will stay on the display momentarily, then disappear, after which the display will show: **CAL 2=**.

CAL 2= - Second Calibration Weight

The display will show **CAL 2=0**. This is the second of two calibration steps.

- Remove the weights on the scale platform, and then press the **ZERO** key.
- The display will advance to **5 10²**.

SETUP AND CALIBRATION, CONT.

Single-Point for Zero Only (Only Zero) Calibration



IMPORTANT! The functions of numeric keys are replaced by using the **UNITS/LEFT ARROW** and the **ASTERISK/UP ARROW** keys. The cursor location is identified by the blinking character and can be advanced to the left to the next position by pressing the **UNITS/LEFT ARROW** key. Pressing the **ASTERISK/UP ARROW** key will change the blinking character to the next value.

$[\text{CAL } 1=$ – First Calibration Weight

The display will show $[\text{CAL } 1=0$. This is the first of two calibration steps.

- Insure the scale is empty.
- Press the **TARE/ENTER** key.
- Starting at the left and advancing right, a series of dashes will appear on the display. The dashes will stay on the display momentarily, then disappear, after which the display will show: $[\text{CAL } 2=$.

$[\text{CAL } 2=$ - Second Calibration Weight

The display will show $[\text{CAL } 2=0$. This is the second of two calibration steps.

- Press the **ZERO** key.
- The display will advance to $5 \text{ } 10^2$.

Calibration “[” Numbers

1. With $[\text{CAL } 1=$ displayed, press the **UNIT** key.
2. At the $[\text{ } 1=$ prompt, press the **TARE/ENTER** key to show the current value of the $[\text{ } 1$ number.
3. If the $[\text{ } 1=$ number displayed is acceptable, press the **TARE/ENTER** key again to save it.
4. Otherwise, use the **ASTERISK/UP ARROW** and **UNITS/LEFT ARROW** keys to enter a new $[\text{ } 1=$ number, then press the **TARE/ENTER** key.
5. Repeat steps 2 through 4 for $[\text{ } 2=$, $[\text{ } 3=$ and $[\text{ } 4=$.



NOTE: If any components have been changed that affect calibration and/or your scale is used in a commercial application and must be "Legal for Trade" you cannot use the “[” numbers to re-calibrate.

SETUP AND CALIBRATION, CONT.

55t² Setup Guardian Scale

If a **GUARDIAN** scale is connected to the indicator, at the 55t² prompt press the **ASTERISK/UP ARROW** key to select **YES**.

The **tLow** prompt will be displayed. This is the low end of the range of weight that requires adjusting. For example, if after performing linearization testing, the displayed weight is 5 lbs low between 10,000 lbs and 15,000 lbs, the value for the tweak low weight is 10000.

Using the **ASTERISK/UP ARROW** and **UNITS/LEFT ARROW** keys, input the tweak low weight value and then press the **TARE/ENTER** key.

The **tHigh** prompt will be displayed. This is the high end of the range of weight that requires adjusting. Using the example above, the value for the tweak high weight is 15000.

Using the **ASTERISK/UP ARROW** and **UNITS/LEFT ARROW** keys, input the tweak high weight value and then press the **TARE/ENTER** key.

The **tURL** prompt will be displayed. This is the amount of weight that needs to be added (or subtracted) from the range of weight to bring the displayed weight into tolerance. Again, using the example above, the Tweak Weight value would be 5.

Using the **ASTERISK/UP ARROW** and **UNITS/LEFT ARROW** keys, input the tweak weight value (pressing the **NET** key will change the sign) and then press the **TARE/ENTER** key to save it and advance to the 5t² menu.

SETUP AND CALIBRATION, CONT.

Sio (*SioP*) - Serial Input/Output

With *Sio* (*SioP*) displayed, press the **TARE/ENTER** key. The display will change to show the current setting *no*. To skip configuring the *Sio* (serial input/output) and proceed to the *PrntP* menu, press the **TARE/ENTER** key again. To configure the *Sio*, press the **ASTERISK/UP ARROW** key (display will change to *YES*) and then press the **TARE/ENTER** key. After pressing the **TARE/ENTER** key, the display will change to *baud*.

baud (Serial Port Baud Rate)

Press the **TARE/ENTER** key to show the current value. If the setting displayed is acceptable, press the **TARE/ENTER** key again to save it. Otherwise, use the **ASTERISK/UP ARROW** key to toggle to a new baud rate for the serial ports and then press the **TARE/ENTER** key to save it. Allowable values are:

12 = 1200 Baud	24 = 2400 Baud	48 = 4800 Baud
96 = 9600 Baud	19 = 19.2k Baud	38 = 38.4k Baud
76 = 76.8k Baud		

Prty (Serial Port Parity)

Press the **TARE/ENTER** key to show the current value. If the setting displayed is acceptable, press the **TARE/ENTER** key again to save it. Otherwise, use the **ASTERISK/UP ARROW** key to toggle to a new setting and then press the **TARE/ENTER** key to save it. Allowable values are:

0 = NONE (No Parity)	1 = Odd Parity	2 = Even Parity
----------------------	----------------	-----------------

bits (Serial Port Data Bits)

Press the **TARE/ENTER** key to show the current value. If the setting displayed is acceptable, press the **TARE/ENTER** key again to save it. Otherwise, use the **ASTERISK/UP ARROW** key to toggle to a new setting and then press the **TARE/ENTER** key to save it. Allowable values are: 7 or 8.

stop (Serial Port Stop Bits)

Press the **TARE/ENTER** key to show the current value. If the setting displayed is acceptable, press the **TARE/ENTER** key again to save it. Otherwise, use the **ASTERISK/UP ARROW** key to toggle to a new setting and then press the **TARE/ENTER** key to save it. Allowable values are: 1 or 2.

Cont 1 (Continuous Output Serial Port 1)

Press the **TARE/ENTER** key to show the current value. If the setting displayed is acceptable, press the **TARE/ENTER** key again to save it. Otherwise, use the **ASTERISK/UP ARROW** key to toggle to a new setting and then press the **TARE/ENTER** key to save it.

<i>Cont 1: YES</i> Continuous Output	<i>Cont 1: no</i> No Continuous Output
---	---

If *Cont 1: YES* (Continuous Output) is selected, an additional prompt, *TYPE* will be displayed.

If *Cont 1: no* (No Continuous Output) is selected, proceed to the Weight On Demand section.

SETUP AND CALIBRATION, CONT.

TYPE - (Continuous Output Format)

Press the **TARE/ENTER** key to show the current value. If the setting displayed is acceptable, press the **TARE/ENTER** key again to save it. Otherwise, use the **ASTERISK/UP ARROW** key to toggle to a new setting and then press the **TARE/ENTER** key to save it. Allowable values are:

0 = SMA	1 = SB-400	2 = SB-200
3 = Rice Lake IQ355	4 = AnDFV	5 = WI110
6 = Number Only	7 = Toledo Long/Short	8 = SB500 with Traffic Light
9 = Ranger 5000 Format A	10 = GEDGE 1650 Format 4	

SMA – (Type = 0)

If SMA is selected, the data will be transmitted in the following format:

```
<lf><s><r><n><m><f><xxxxxx.xxx><uuu><cr>
```

Where:

lf =	Line Feed	
s =	Flags	Z= center of Zero, O = Overcap, E = zero Error, e = weight not currently being displayed
r =	Range	1, 2, 3, ...
n =	Mode	G = Gross, T = Tare, N = Net
m =	Motion	M = Motion, " "(blank) = no motion
f =	Custom	Custom flag
xxxxxx.xxx =	Weight	Six digits with decimal point
uuu =	Units	ton, lb , l/o, oz , t , kg , g
cr =	Carriage Return	(hex 0D)

SB-400 – (Type = 1)

If SB-400* or Computer is selected, the data will be transmitted in the following format:

```
<s><xxxxxx><d><uu><m><cc><cr>
```

Where:

s =	Sign	"-" = negative, " " (blank) = positive
xxxxxx.xxx =	Weight	Six digits
d =	Decimal point	Added to string if enabled in setup
uu =	Units	tn, lb, l/o, oz, t, kg, g
m =	Mode	G = Gross, N = Net
cc =	Weight Status	OC = overcap CZ = center of zero MO = motion ee = weight not currently being displayed
cr =	Carriage Return	(hex 0D)

*The SB-80, SB-300 (*multiple displays not supported*) and WinVRS use the SB-400 format.

SETUP AND CALIBRATION, CONT.

SB-200 – (Type = 2)

If SB-200 is selected, the data will be transmitted in the following format:

<cr><s><xxxxxx><d><c><uu><m> ETX

Where:

cr =	Carriage Return	(hex 0D)
s =	Sign	"-" = negative, " " (<i>blank</i>) = positive
xxxxxx.xxx =	Weight	(with leading zeros)
d =	Decimal point	Embedded into weight (after weight dpp=0)
c =	status	m = motion o = overcap e = weight not currently being displayed
uu =	Units	tn, lb, l/o, oz, t, kg, g
m =	Mode	G = Gross, N = Net
ETX =	End of TeXt	(hex 03) MUST terminate ALL serial commands

Rice Lake IQ355 – (Type = 3)

If Rice Lake IQ355 is selected, the data will be transmitted in the following format:

<stx><s>xxxxxxx<u><m><s><cr><lf>

AnDFV – (Type = 4)

If AnDFV is selected, the data will be transmitted in the following format:

<hdr1>,xxxxx<uu><cr><lf>

WI110 – (Type = 5)

If WI110 is selected, the data will be transmitted in the following format:

<m><sp><s>xxxxx<sp><uu><cr><lf>

Number Only – (Type = 6)

If number only is selected, the data will be transmitted in the following format:

xxxxxx<cr><lf>

Toledo Short – (Type = 7)

If Toledo Short is selected, the data will be transmitted in the following format:

<stx><swa><swb><swc>xxxxxx<cr><sum>

Toledo Long – (Type=7)

If Toledo Long is selected, the data will be transmitted in the following format:

<stx><swa><swb><swc>xxxxxyyyyyy<cr><sum>

Where:

xxxxxx =	Weight	(leading zeros suppressed)
yyyyyy =	Tare Weight	(leading zeros suppressed)

SETUP AND CALIBRATION, CONT.

SB500 (with Traffic Light) – (Type = 8)

If SB500 (with Traffic Light) is selected, the data will be transmitted in the following format:

%NDDDDDDDDDT<CR>

Where:

N = Panel number for a daisy chain configuration

D = Byte of data to display at respective location on the scoreboard

T = Control character for the traffic light. Valid characters for T are:

G = Turn on Green light

R = Turn on Red light

" "(space) = no lights on

<CR> = Carriage Return

Ranger 5000 Format A – (Type = 9)

In setup, after selecting type 9 for the Ranger 5000 Format A:

At the *StArtb* prompt, enter the decimal value for the start character.
Valid entry is 0 to 126.

At the *Endb 1* prompt, enter the decimal value for the first end character.
Valid entry is 0 to 126.

At the *Endb 2* prompt, enter the decimal value for the second end character.
Valid entry is 0 to 126.

If the above items are '0' then the character will not be included in the data stream.

If Ranger 5000 Format A is selected, the data will be transmitted in the following format:

<StArtb>Sign WeightA(7) Status

Where:

Sign = The sign of the weight ('+' for positive, '-' for negative)

WeightA = A seven character string containing the current weight including the decimal point. If there is no decimal point, then the first character is a space.
Leading zero blanking applies.

Status = Provides information on the weight reading. The characters G/N/U/O/M/E represent Gross/Net/Underload/Overload/Motion/Error respectively.

SETUP AND CALIBRATION, CONT.

GEDGE 1650 FORMAT 4 – (Type = 10)

In setup, after selecting type 10 for the GEDGE 1650 Format 4:

At the *t d R t E* prompt, enter the format for the date and time (0-4).

At the *S t r t C* prompt, enter the decimal value for the start character (0-126)

At the *E b L o C* prompt, enter the decimal value for the end block character or data separator (0-126).

At the *d b U b* prompt, enter the decimal value for the device number (0-99).

Format

<Bg><DT><BD><No><BD><W1><BD><D2><D3><D4><D5><D6><D7><BD><En>

Where:

- Bg is the starting character, if 0 then it is not transmitted.
- DT is the Date and Time the following BD character is output only if the date/time is output.
- BD Block division character.
- D2 Displayed weight identity. **G**=gross, **N**=net
- D3 **M** scale is in motion, **S** scale is stable.
- D4 Inscale (0>=weight<=capacity) **O**vercap **U**=below zero
- D5 **Z**=Center-of-Zero, otherwise ASCII space
- D6 **E**=Tare not equal to 0, otherwise ASCII space
- D7 Always an ASCII space
- En End of transmission character
- No Device Number 01 thru 99. If set to 0 above, then nothing is output.
- W1 Displayed weight.

Weight On Demand

If continuous output has not been selected for Serial Port 1 (Cont1=NO), the 200 indicator will respond to a weight request (ENQ).

The host device (computer) sends:

ENQ - (hex 05)

The 200 will respond:

<s><xxxxxx><d><uu><m><cc><cr>

Where:

- | | | |
|--------------|-----------------|---|
| s = | Sign | "-" = negative, " " (<i>blank</i>) = positive |
| xxxxxx.xxx = | Weight | Six digits |
| d = | Decimal point | Added to string if enabled in setup |
| uu = | Units | tn, lb, l/o, oz, t, kg, g |
| m = | Mode | G = Gross, N = Net |
| cc = | Weight Status | OC = overcap
CZ = center of zero
MO = motion
ee = weight not currently being displayed |
| cr = | Carriage Return | (hex 0D) |

NOTE: The Weight On Demand function is not available for Serial Port 2.

SETUP AND CALIBRATION, CONT.

`Cont2:` (Continuous Output Serial Port 2)

Press the **ENTER** key to show the current value. If the setting displayed is acceptable, press the **ENTER** key again to save it. Otherwise, using the arrow keys, select a new setting then press the **ENTER** key to save it.

`Cont2: YES`
Continuous Output

`Cont2: no`
No Continuous Output

If `Cont2: YES` (Continuous Output) is selected, an additional prompt, `TYPE:` will be displayed.

`TYPE:` (Continuous Output Format)

Press the **TARE/ENTER** key to show the current value. If the setting displayed is acceptable, press the **TARE/ENTER** key again to save it. Otherwise, use the **ASTERISK/UP ARROW** key to toggle to a new setting and then press the **TARE/ENTER** key to save it. Allowable values are:

0 = SMA	1 = SB-400	2 = SB-200
3 = Rice Lake IQ355	4 = AnDFV	5 = WI110
6 = Number Only	7 = Toledo Long/Short	8 = SB500 with Traffic Light
9 = Ranger 5000 Format A	10 = GEDGE 1650 Format 4	

NOTE: See Continuous Output Serial Port 1, `TYPE:` for description of output formats.

`THRS:` (Threshold Weight)

If any of the Serial Ports have been configured for continuous SB-500 with Traffic Light output, this prompt will be displayed.

Press the **TARE/ENTER** key to show the current value. If the setting displayed is acceptable, press the **TARE/ENTER** key again to save it. Otherwise, use the **ASTERISK/UP ARROW** and **UNITS/LEFT ARROW** keys to enter a new setting for the threshold weight and then press the **TARE/ENTER** key to save it.

The threshold weight is used to automatically toggle between the Red and Green lights.

- When the scale gross weight is less than the threshold weight, the Green light will be on, otherwise the Red light will turn on and stay on until the weight goes below the threshold weight or a ticket is printed.
- When a ticket is printed, the Green light will turn on and stay on until the scale gross weight goes below and back above the threshold weight and then the Red light will turn on.
- **NOTE:** If you enter a zero (0) for the threshold weight (`THRS: 0`), the traffic light feature will be disabled (turned off).

SETUP AND CALIBRATION, CONT.

Print (*Print*) – Print Tab Settings

With *Print* (*Print*) displayed, press the **TARE/ENTER** key. The display will change to show the current setting *no*. To skip configuring the Print Tab Settings and proceed to the *F5PRn* menu, press the **TARE/ENTER** key again. To configure the Print Tab Settings, press the **ASTERISK/UP ARROW** key (display will change to *YES*) then the **TARE/ENTER** key. After pressing the **TARE/ENTER** key the display will change to *Port*.

The general format for the input is A = YY.XX where A is the character identifying the data printed, YY is the number of lines down and XX is the number of spaces to the right.

NOTE: Enter 00 in either the YY or XX location to disable the data from printing.

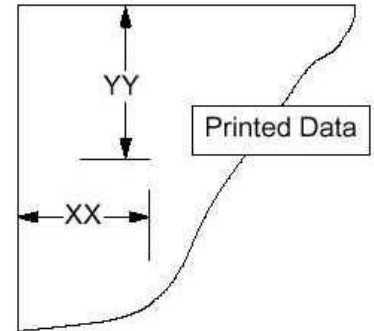

Port = (Select Port for Printer)

Press the **TARE/ENTER** key to show the current value. If the setting displayed is acceptable, press the **TARE/ENTER** key again to save it. Otherwise, use the **ASTERISK/UP ARROW** key to toggle to a new setting and then press the **TARE/ENTER** key to save it. Allowable values are: 1 or 2.



NOTE: Although either port can be used for the printer port, it is recommended to use the bi-directional port 1 with a bi-directional cable.

id = (ID Prompt Print Location)

Press the **TARE/ENTER** key to show the current setting for the location of ID prompt printing. If the setting displayed is acceptable, press the **TARE/ENTER** key again to save it. Otherwise, use the **ASTERISK/UP ARROW** and **UNITS/LEFT ARROW** keys to input a new location and then press the **TARE/ENTER** key to save it.

cn = (Consecutive Number Print Location)

Press the **TARE/ENTER** key to show the current setting for the location of consecutive number printing. If the setting displayed is acceptable, press the **TARE/ENTER** key again to save it. Otherwise, use the **ASTERISK/UP ARROW** and **UNITS/LEFT ARROW** keys to input a new location and then press the **TARE/ENTER** key to save it.

gross = (Gross Weight Print Location)

Press the **TARE/ENTER** key to show the current setting for the location of Gross weight printing. If the setting displayed is acceptable, press the **TARE/ENTER** key again to save it. Otherwise, use the **ASTERISK/UP ARROW** and **UNITS/LEFT ARROW** keys to input a new location and then press the **TARE/ENTER** key to save it.

tare = (Tare Weight Print Location)

Press the **TARE/ENTER** key to show the current setting for the location of Tare weight printing. If the setting displayed is acceptable, press the **TARE/ENTER** key again to save it. Otherwise, use the **ASTERISK/UP ARROW** and **UNITS/LEFT ARROW** keys to input a new location and then press the **TARE/ENTER** key to save it.

net = (Net Weight Print Location)

Press the **TARE/ENTER** key to show the current setting for the location of Net weight printing. If the setting displayed is acceptable, press the **TARE/ENTER** key again to save it. Otherwise, use the **ASTERISK/UP ARROW** and **UNITS/LEFT ARROW** keys to input a new location and then press the **TARE/ENTER** key to save it.

SETUP AND CALIBRATION, CONT.

G REC = (Gross Weight Accumulator Print Location)

Press the **TARE/ENTER** key to show the current setting for the location of Gross weight accumulator printing. If the setting displayed is acceptable, press the **TARE/ENTER** key again to save it. Otherwise, use the **ASTERISK/UP ARROW** and **UNITS/LEFT ARROW** keys to input a new location and then press the **TARE/ENTER** key to save it.

n REC = (Net Weight Accumulator Print Location)

Press the **TARE/ENTER** key to show the current setting for the location of Net weight accumulator printing. If the setting displayed is acceptable, press the **TARE/ENTER** key again to save it. Otherwise, use the **ASTERISK/UP ARROW** and **UNITS/LEFT ARROW** keys to input a new location and then press the **TARE/ENTER** key to save it.

[rLF = (Carriage Return Line Feed) - Data Format Termination

Data transmitted from the serial I/O port can be terminated with a single carriage return and either no line feed or a single line feed command. Press the **TARE/ENTER** key to view the current setting. A **YES** on the display means the data will be terminated with a carriage return AND a line feed while a **no** on the display means the data will be terminated with a single carriage return only.

If the setting displayed is acceptable, press the **TARE/ENTER** key again to save it. Otherwise, use the **ASTERISK/UP ARROW** key to toggle to a new setting and then press the **TARE/ENTER** key to save it.

EOP = (End-Of-Print Line Feeds)

At the end of a data transmission to a printer, the indicator can transmit a pre-selected number of line feed commands to space the paper in the printer to the desired position for withdrawal or for the next print.

Press the **TARE/ENTER** key to view the current setting. If the displayed value is acceptable, press the **TARE/ENTER** key to save it. Otherwise, use the **ASTERISK/UP ARROW** and **UNITS/LEFT ARROW** keys to input the number of End-Of-Print linefeeds and then press the **TARE/ENTER** key to save it. Allowable values are: 0 through 99.

SETUP AND CALIBRATION, CONT.

F SPAN (*FSPAN?*) - Fine Span Adjustment



NOTE: The *FSPAN* and *H RES* modes require a load of 10% of Capacity be on the scale before adjustments can be made.

With the *F SPAN?* prompt displayed after pressing the **TARE/ENTER** key at the last Print prompt:

With *FSPAN?* displayed, press the **TARE/ENTER** key. The display will change to show the current setting *no*. To skip the Fine Span Adjustment and return to the *SETUP* menu, press the **TARE/ENTER** key again. To perform the Fine Span Adjustment, place a calibrated test weight on the scale and press the **ASTERISK/UP ARROW** key (display will change to *YES*) and then the **TARE/ENTER** key.

After pressing the **TARE/ENTER** key, the display will change to show the amount of the test weight and the annunciators will alternately flash off and on i.e. (all ON, weighing unit off, then all OFF, weighing unit ON). Press the **ASTERISK/UP ARROW** key to increase the span OR press the **UNITS/LEFT ARROW** key to decrease the span. Press the **ASTERISK** key to return to the previous prompt or press the **TARE/ENTER** key to exit *FSPAN?* and return to the *SETUP* menu.

With the *F SPAN* prompt displayed after pressing the Calibration switch:

With *F SPAN* displayed, place a calibrated test weight on the scale and press the **TARE/ENTER** key. After pressing the **TARE/ENTER** key, the display will change to show the amount of the test weight and the annunciators will alternately flash off and on (all ON, weighing unit off, then all OFF, weighing unit ON). Press the **ASTERISK/UP ARROW** key to increase the span OR press the **UNITS/LEFT ARROW** key to decrease the span. Press the **ASTERISK/UP ARROW** key to return to the previous prompt or press the **TARE/ENTER** key to exit *F SPAN* and return to the *SETUP* menu.

H RES - Display High Resolution Weight

With *H RES* on the display, pressing the **TARE/ENTER** key will show the active weight in "high resolution" mode (in 1/10 interval). Press the **PRINT** key to print the weight (followed by the text TEST) via the selected printer output port enabled during setup and calibration. Press the **TARE/ENTER** key to return to the *H RES* prompt. To exit the *H RES* mode, press the calibration switch or cycle power (press the **ON/OFF** key twice).

Lockout - Key Lock Out Function

With *Lockout* on the display, pressing any key will display *Lock* (locked) or *UnLock* (unlocked) for the current key state. Pressing a locked key during normal operation will result in a 1/2 second display *Lock* and the key will be ignored. To exit the *Lockout* function, press the calibration switch or cycle power (press the **ON/OFF** key twice).



NOTE: The menu selections *H RES* and *Lockout* can only be selected using the calibration switch.

Option - Option Card Configuration

This prompt will ONLY be displayed when a 2XX Option Card is installed in the indicator. Refer to the manual for the 2XX option card installed for setup instructions.

SETUP REVIEW

The Model 200 Weight Indicator allows several operational parameters to be reviewed and changed without breaking the calibration seal. These operational parameters are:

Power Up Zero Reset Enable/Disable
Sleep Mode Feature Enable/Disable
Auto Shutoff Feature Enable/Disable
Clear Tare Feature Enable/Disable

Serial Input / Output Configuration
Baud Rate
Parity
Number of Data Bits
Number of Stop Bits
Continuous Output Port 1
 Continuous Output Format
 Type
Continuous Output Port 2
 Continuous Output Format
 Type

Print Tab Settings
Printer Port Selection
Gross Weight
Tare Weight
Net Weight
Gross Weight Accumulator
Net Weight Accumulator
CRLF Data Format Termination
End-Of-Print Line Feeds

To enable the Setup Review feature, with the indicator ON:

1. Press the **ASTERISK/UP ARROW** key. The indicator will respond by showing the *Funct=* (Function) prompt and alternately flashing off and on (all ON, weighing unit off, then all OFF, weighing unit ON) the annunciators.
2. Press the **ZERO/REVIEW** key. The display will change to the prompt for the selection of power-up zeroing (*PU0=*).
3. Using the same procedure as described in the Setup and Calibration section of this manual make the required changes.
4. Press the **ASTERISK/UP ARROW** key to return to the previous prompt.
5. To exit Setup Review, press the **ASTERISK/UP ARROW** key to step through the remaining prompts *OR* at anytime, cycle the power (press the **ON/OFF** key twice).

CALIBRATION “C” NUMBERS

The “C” numbers are displayed only during the Test mode operation by pressing the **ASTERISK/UP ARROW** key then the **UNITS/TEST** key. The “C” numbers are shown at the end of the test operation and each number is displayed for approximately 4 seconds, allowing you to record them. Each number may be up to three (3) digits in length. By recording these numbers you will be able to return the indicator to its present calibration settings without using test weights simply by entering the “C” numbers.

1. With $C_{RL} 1=$ displayed, press the **UNIT** key.
2. At the $C 1=$ prompt, press the **TARE/ENTER** key to show the current value of the $C 1$ number.
3. If the $C 1=$ number displayed is acceptable, press the **TARE/ENTER** key again to save it.
4. Otherwise, use the **ASTERISK/UP ARROW** and **UNITS/LEFT ARROW** keys to enter a new $C 1=$ number, then press the **TARE/ENTER** key.
5. Repeat steps 2 through 4 for $C 2=$, $C 3=$ and $C 4=$.



NOTE: If any components have been changed that affect calibration and/or your scale is used in a commercial application and must be "Legal for Trade" you cannot use the “C” numbers to re-calibrate.

ACCUMULATORS

To *view* the NET accumulator:

1. Press the **ASTERISK/UP ARROW** key then the **NET/GROSS** key.
2. Press the **ASTERISK/UP ARROW** key to return to normal operation.

To *print* the NET accumulator:

1. Press the **ASTERISK/UP ARROW** key, the **NET/GROSS** key, then the **PRINT** key
2. The indicator will return to normal operation when printing has been completed.

To *clear (zero)* the NET accumulator:

1. Press the **ASTERISK/UP ARROW** key, the **NET/GROSS** key, then the **ZERO** key
2. Press the **ASTERISK/UP ARROW** key to return to normal operation.

To *view* the Gross accumulator:

1. Press the **ASTERISK/UP ARROW** key then the **NET/GROSS** key twice.
2. Press the **ASTERISK/UP ARROW** key to return to normal operation.

To *print* the Gross accumulator:

1. Press the **ASTERISK/UP ARROW** key, the **NET/GROSS** key twice, then the **PRINT** key
2. The indicator will return to normal operation when printing has been completed.

To *clear (zero)* the Gross accumulator:

1. Press the **ASTERISK/UP ARROW** key, the **NET/GROSS** key twice, then the **ZERO** key
2. Press the **ASTERISK/UP ARROW** key to return to normal operation.

TROUBLESHOOTING

Error Codes

The Model 200 Weight Indicator is equipped with software that indicates when an error in the operation takes place. The following lists the error codes displayed by the indicator along with their meaning. Should you encounter an error code, please refer to this list for the cause.

Cal (Calibration button)

Cal will be displayed (until the condition changes), on power-up if the calibration switch is pressed in by the operator or the switch is defective.

CORRECTIVE ACTION: Release the switch. Replace calibration switch assembly. Consult your scale service provider.

Conf (Configuration)

E²PROM checksum failure. Indicates improper stored calibration data, calibration is necessary.

CORRECTIVE ACTION: Recalibrate with calibrated test weight.

Error (Error)

An invalid keypad entry was attempted:

- A. **PRINT** key pressed with a negative weight.
- B. **TARE/ENTER** key pressed to enter a push button tare value of a negative value.
- C. **TARE/ENTER** key pressed to enter a tare weight value that exceeds the scale capacity.
- D. **TARE/ENTER** key pressed to enter a tare weight value that is inconsistent with the scale division value (i.e. attempt to enter a tare of 123 with scale divisions of 5).
- E. **ZERO** key pressed when the gross weight is outside the scale zero weight range.
- F. **UNITS/TEST** key pressed to change to kg when the kg tare weight value exceeds 4 digits in length.

CORRECTIVE ACTION: Determine which of the reasons for the error display is applicable and take the appropriate corrective action.

ErrorH (Error Analog high)

1. The load cell input is above the range of the indicator.

CORRECTIVE ACTION: Check for improper load cell wiring, excessive load, and for output of 1 to 40mV.

2. Load cell or circuit failure.

CORRECTIVE ACTION: Consult your scale service provider.

ErrorL (Error Analog Low)

1. The load cell input is below the range of the indicator.

CORRECTIVE ACTION: Check for improper load cell wiring and for output of 1 to 40mV.

2. Load cell or circuit failure.

CORRECTIVE ACTION: Consult your scale service provider.

TROUBLESHOOTING, CONT.

Error Codes, Cont.

Error 1 (Error 1)

A program checksum mismatch has been detected.

CORRECTIVE ACTION: Consult your scale service provider.

Error 3 (Error 3)

Internal RAM failure.

CORRECTIVE ACTION: Consult your scale service provider.

HuH? (HuH?)

UNITS key pressed in an attempt to perform a unit conversion that is not allowed.

CORRECTIVE ACTION: Determine the reason for the error display and take the appropriate corrective action.

no tarE (no tarE)

NET key pressed with no stored tare weight value.

CORRECTIVE ACTION: Determine the reason for the error display and take the appropriate corrective action.

oCAP (over Capacity)

The load on the scale exceeds the scale capacity plus nine (9) divisions.

CORRECTIVE ACTION: Remove the over capacity load from the scale platform. May indicate an incorrect calibration.

-oF- (overflow)

The indicator is attempting to display a positive number greater than six (6) digits in length or a negative number of more than five (5) digits.

CORRECTIVE ACTION: Return to Gross Weight mode and review Tare value. May indicate an incorrect calibration.

too big (too big)

UNITS key pressed in an attempt to perform a unit conversion where the interval would have been greater than 50.

CORRECTIVE ACTION: Determine the reason for the error display and take the appropriate corrective action.

UnStb (Unstable)

Motion is present when trying to perform a print function.

CORRECTIVE ACTION: Wait for a stable weight display (*STABLE* annunciator on) before performing any of this operation.

TROUBLESHOOTING, CONT.

Before You Call For Service

The Model 200 Weight Indicator has been designed to provide you with years of trouble-free operation. In spite of this, troubles sometimes happen. Before calling for service assistance you should make some initial checks to verify that a problem does exist. The following describes several types of symptoms along with suggested remedies.

PROBLEM	POSSIBLE SOLUTIONS
Display does not turn on	AC operation: Is the AC power cord fully inserted into the wall receptacle? Check wall receptacle for proper AC power. Try another electrical appliance in the same receptacle, does it work? Check the circuit breaker. Has there been power failure?
Incorrect weight displayed	Has the indicator been calibrated? Insure that the scale platform isn't touching an adjacent object. Check the load cell connector wiring. If using four (4) wire load cells, insure the sense lead jumpers (J4 & J5) are installed. Have proper operation procedures been followed?
Indicator will not display weight	Refer to Error Codes section and make certain that the "oCAP" message is not displayed. If so, and scale is not loaded, perform the calibration sequence.
The printer prints but does not use the Print Tab Settings or prints a test ticket	<p>The print tab setting or visual ticket format must be selected prior to beginning the weighing operation or just prior to printing the ticket.</p> <p>To select the ticket format prior to beginning the weighing operation:</p> <ol style="list-style-type: none"> 1. Press the ASTERISK/UP ARROW key then the PRINT key. The display will change to the "Pr t =". 2. Press the TARE/ENTER key to show the current value. 3. If the value displayed is acceptable, press the TARE/ENTER key again to save it. 4. If the displayed value is incorrect (or another ticket format is desired), use the ASTERISK/UP ARROW key to toggle to a new setting and then press the TARE/ENTER key to save it. <p>Allowable values for ticket formats are:</p> <ul style="list-style-type: none"> 0 = print tab settings 1 = visual ticket format 1 2 = visual ticket format 2 <p>NOTE: When a print format is selected (by either method), it will remain active until changed by the operator.</p>

TROUBLESHOOTING, CONT.

Diagnostic Test Mode

To Start Diagnostic Test Mode

1. Remove calibration access screw.
2. Press **ON/OFF** key to turn indicator ON.
3. Insert a small screwdriver or other tool into the access hole and press the CAL switch.
4. Display will change to *SEtUP*.
5. Press **UNITS/TEST** key.
6. Display will change to *tEtE-*.
7. Press **TARE/ENTER** key to show current test function value (which will be 0, test feature off).
8. Using the **UNITS/LEFT ARROW** and **ASTERISK/UP ARROW** keys, enter test function value and then press **ENTER** key.
 - 4 = raw A/D readings**
 - 16 = display milliVolts**
9. Display will change to *SEtUP*.
10. Press **ASTERISK/UP ARROW** key to begin test.
11. Display will change to show test data.

To Change Diagnostic Test Mode

1. With indicator displaying test data, insert a small screwdriver or other tool into the access hole and press the CAL switch.
2. Display will change to *SEtUP*.
3. Press **UNITS/TEST** key.
4. Display will change to *tEtE-*.
5. Press **TARE/ENTER** key to show current test function value.
6. Using the **UNITS/LEFT ARROW** and **ASTERISK/UP ARROW** keys, enter test function value and then press **ENTER** key.
 - 4 = raw A/D readings**
 - 16 = display milliVolts**
7. Display will change to *SEtUP*.
8. Press **ASTERISK/UP ARROW** key to begin test.
9. Display will change to show test data.

To Stop Diagnostic Test Mode

1. With indicator displaying test data, insert a small screwdriver or other tool into the access hole and press the CAL switch.
2. Display will change to *SEtUP*.
3. Press **UNITS/TEST** key.
4. Display will change to *tEtE-*.
5. Press **TARE/ENTER** key to show current test function value.
6. Using the **UNITS/LEFT ARROW** and **ASTERISK/UP ARROW** keys, enter a 0 for the test function value (0 = test feature off) and then press **TARE/ENTER** key.
7. Display will change to *SEtUP*.
8. Press **ASTERISK/UP ARROW** key to stop test and reset indicator.
9. The indicator is now ready for normal operation.



IMPORTANT! Once Diagnostic Test Mode has been enabled, the indicator will power on with *tEtE-* on the display. Operator must press **TARE/ENTER** key to stay in Diagnostic Test Mode or press **ASTERISK/UP ARROW** key to disable Diagnostic Test Mode.

CALIBRATION SEAL INSTALLATION

If your Model 200 Weight Indicator is used in a commercial application it must be tested and sealed by your local weights and measurements official. The indicator is designed to accept a lead and wire security seal to prevent unauthorized access to the calibration adjustments. Refer to Figure No. 12 for details on the installation of the seal.

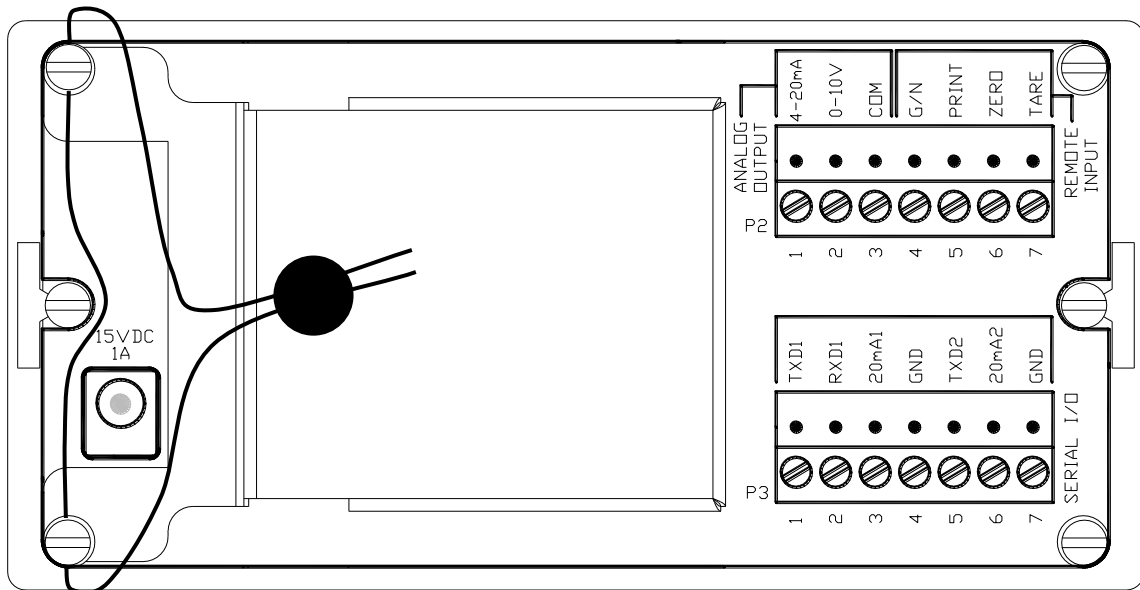

Figure No. 12

LOCAL/REMOTE SETUP

If the indicator is to function as a remote indicator, at the `5ER5LL` (REMOTE INDICATOR SETUP) prompt, press the **ASTERISK/UP ARROW** key to select **YES** and then press the **TARE/ENTER** key.

With `5ER5LL` set to YES, the `LRP=` (Local/Remote Port) will be displayed to select the serial port for the LOCAL/REMOTE communications.

With the `LRP=` (Local/Remote Port) displayed, press the **TARE/ENTER** key to show the current setting. If the setting displayed is acceptable, press the **TARE/ENTER** key again to save it. Otherwise, use the **ASTERISK/UP ARROW** key to toggle to a new setting and then press the **TARE/ENTER** key to save it. Allowable values are: **1** for port 1 or **3** for the optional 2xx-RS232 card (if installed).

Any unused RS-232 serial port may be used (see Figure 13 for port 1 interconnect wiring). Note that this is for distances less than 100 feet.



IMPORTANT! The selected serial port (`5SER`) for the remote indicator must be configured the same as the serial port used for the local indicator. In addition, the Continuous Output must be set to NO (`CONT=NO`).

Local/Remote 200 RS-232 Wiring

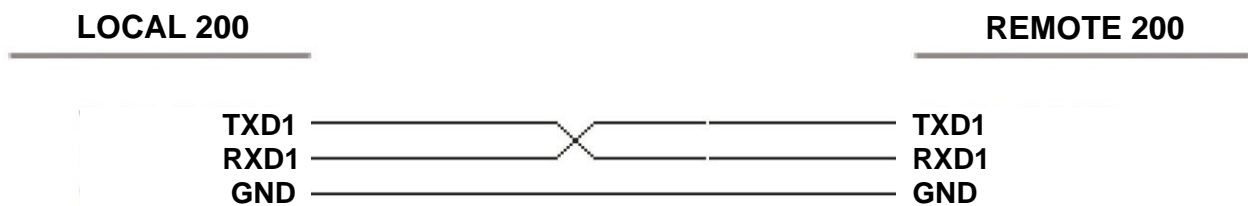

Figure No. 13

PART IDENTIFICATION

ITEM NO.	QTY.	PART NUMBER	DESCRIPTION
1	1	5930-B047-08	LABEL: REMOVE PROTECTIVE FILM
2	1	593GR986	SERIAL TAG ASSEMBLY
3	8	6021-0210	SCW FILLISTER #6-32 X .625 Z.P.
4	2	6021-0605	#8-32 x .375 SLOT DR. FILLISTER HD
5	2	6021-0629	SCW FLAT-HEAD MACHINE SCW 06-32X0.500
6	2 (3)	6021-0654	SCW PAN HEAD #6-32 x .250 PDMS
7	4	6025-0031	WASHER LOCK HELICAL SP REG #6 Z-PL
8	1	6540-0200	PANEL MOUNT ENCLOSURE
9	2 (3)	6680-0004	WASHER LOCK INT. TOOTH #6 Z/P
10	1	8200-B028-08	FRONT PANEL
11	(1)	8200-B032-0A	CABLE: ANALOG OUTPUT
12	1	8200-C003-0A	DISPLAY BOARD
13	1	8200-C004-0A	REAR PANEL
14	1	8200-C029-08	REAR PANEL SEAL
15	(1)	8200-C210-0A	DAC PCB
16	1	8200-D001-0A	PCB ASSEMBLY – 200 CONTROLLER BOARD
17	1	8200-D002-08	KEYPAD
18	1	5930-B126-08	LABEL: ETL FOR 180/200/204/750/758C
*	1	6800-1035	AC ADAPTER 90-264VAC/15VDC @ 1AMP

* NOT SHOWN

NOTE: Quantities in () parenthesis are used on the 200-A only.

PART IDENTIFICATION, CONT.

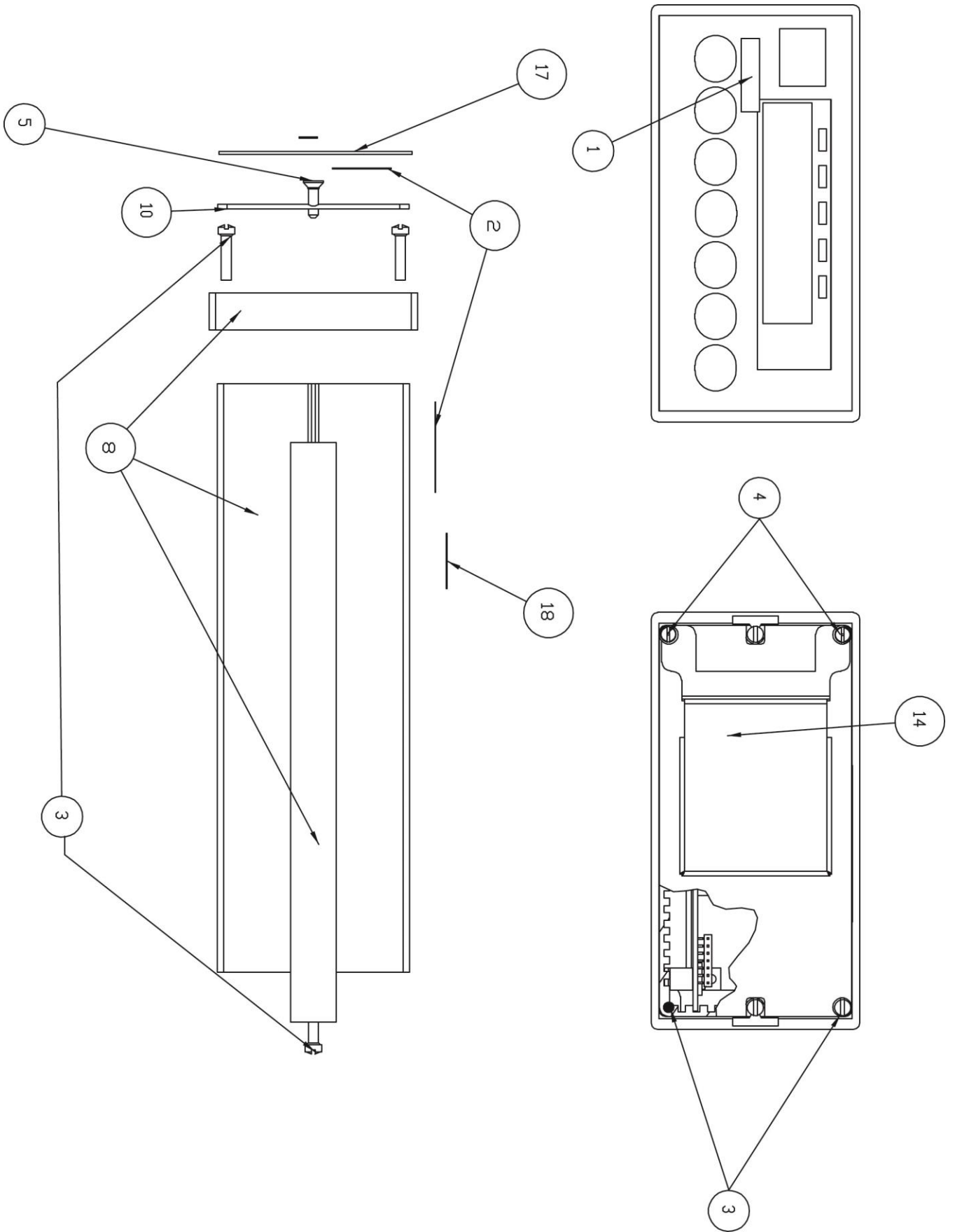

PART IDENTIFICATION, CONT.

