

2200 Series

Process Control Digital Weight Indicator

Technical Manual



Table of Contents

Introduction	1
Unpacking Your Scale.....	1
Specifications	2
Scale Controls and Operation	3
Scale Annunciators	3
Powering On.....	4
Basic Weighing Operation.....	4
ZERO.....	4
TARE.....	5
Keyboard TARE entry	5
Display TARE value	5
Clear TARE value.....	5
GROSS NET selection.....	5
UNITS	5
PRINT.....	5
START	5
STOP.....	5
Setpoint and Output Operation	7
Enter SETPOINT Target Weight.....	7
Display SETPOINT Target Weight.....	7
Setpoint Learning Preacts	7
Enter Setpoint Preact Weight.....	8
Display Setpoint Preact Weight.....	8
Tank Level Maintenance Mode	9
Battery Operation.....	10
Power Off	10
Low Battery Indication	10
Recharging Battery	10
Product ID	11
Recall PRODUCT ID from Memory.....	11
Barcode Scan Recall PRODUCT ID from Memory	11
Display Current PRODUCT ID.....	11
Create New PRODUCT ID	11
Delete PRODUCT ID from Memory.....	12
Product Fields.....	12
Display Product Fields.....	12
Product Field Entry	12
Batch Program Operation	13
Load a Batch Program into Memory.....	13
Start a Batch Program	13
Pause a Running Batch Program.....	13
Stop a Running Batch Program.....	13
Batch Commands.....	14
Time and Date	16

Setting Time and Date.....	16
Accumulator and Counter	17
Accumulator and Counter Operation	17
Display Accumulator and Counter Values.....	17
Clear Accumulator and Counter	17
Accumulator and Counter Data String Output to Printer or Data Collection	17
Installation Guide	18
Removing and Replacing the Rear Panel	18
Heartbeat LED.....	18
Load Cell Connection	19
Power Connection and Fuse.....	20
RS232 and Remote Switch Connection.....	20
Output Connections.....	22
Calibration Guide.....	23
Entering Calibration and Parameter Setup Mode	23
Exit Calibration and Parameter Setup Mode	23
Set Scale Capacity	23
Set Scale Count By	24
Calibration	24
Scale Calibration Troubleshooting.....	25
Scale Parameter Setup.....	26
Entering Calibration and Parameter Setup Mode	26
Exit Calibration and Parameter Setup Mode	26
Navigating Parameter Menu with Keypad.....	26
Navigating Parameter Menu with ZERO, UNITS, and PRINT.....	27
Parameter Groups	27
Legal for Trade Restrictions.....	27
Audit Counters.....	27
Software Part Number and Revision Level	28
Capacity and Calibration - 1 CAL	29
General Settings - 2 CONF	32
Serial (RS232) Port 1 - 3 SER 1	35
Serial (RS232) Port 2 - 4 SER 2	36
Wired Ethernet - 5 ETH	38
Wireless Ethernet - 6 WIF	40
Bluetooth - 7 BT	43
USB - 8 USB	44
Setpoints and Output Operation - 9 OPER	45
Exit - 99 done	46
Data Communications	47
Data String Formatting.....	48
Custom Data String Configuration.....	52
Remote Commands	55
Internal Relay Option	58
Internal Relay Setup:	58
Relay Specifications:	58
Step-up Relay Circuit.....	59

External Relay Box Option	60
External Relay Setup:	61
4-20mA Analog Output Option	62
Wired Ethernet Option	63
Wireless 802.11b/g Ethernet Option.....	64
Troubleshooting Wifi	65
Bluetooth Option.....	66
Bluetooth Pairing Instructions.....	67
Troubleshooting	71
Scale Messages	72
Default to Factory Settings.....	73
Scale Default Settings	73

Introduction

Thank you for purchasing a Doran Scales product. Please read this manual to ensure obtaining all the benefits that the 2200 can provide. This manual is intended for revision 5.3 and greater scales. If required, Doran can upgrade the software in your scale to the current revision. Please contact the Doran Scales Technical Support Department at tech@doranscales.com for upgrade details.

Unpacking Your Scale

Before unpacking your Doran scale, please read the instructions in this section. Your new scale is a durable industrial product, but it is also a sensitive weighing instrument. Normal care should be taken when handling and using this product. Improper handling or abuse can damage the scale and result in costly repairs that will not be covered by the warranty. If you notice any shipping damage, notify the shipper immediately. Please observe the following precautions to insure years of trouble-free service from your new scale.

- DO NOT drop the scale
- DO NOT immerse the scale
- DO NOT drop objects on the platform
- DO NOT pick up the scale by the top of the weighing platform
- Carefully remove the scale from the shipping carton

Specifications

NTEP Certificate	Class III – 10,000d; Cert. #06-101
CWM Certificate	Class III – 10,000d; Cert. #AM-5617
Enclosure	304 Stainless Steel
Product Dimensions	10" W x 6.75" H x 3.5" D
Environmental Protection	IP69K
Legal for Trade Temperature Range	14 F to 104F (-10 C to +40 C)
Resolution Range	200d to 100,000d
Analog Signal Sensitivity	0.16 μ V/e minimum, 0.5 μ V/e typical
System Linearity	0.01% full scale
Analog Signal Range	-0.5mV/V to 5 mV/V with 4 and 6 wire input
Excitation Voltage	5 VDC
Number of Load Cells	Up to 8 350 Ohm
Scale Inputs	One
Calibration Range	Calibrate between 2% and 100% of capacity
Power Input	100 – 240VAC 50/60Hz
Battery Option	Internal Rechargeable Sealed Lead Acid Battery 6VDC, 60 hours of continuous use, 1000 recharge cycles
Display	0.8" high, 6 digit LED
Displayed Units	lb, kg, oz, g, lb:oz
Capacity Range	1 to 999,000 lb
Serial Interface	Two Bi-directional RS-232 ports standard
Communication Options	Ethernet Wi-Fi – 802.11b/g Bluetooth – 4.0, Class 3, SPP Protocol USB – 2.0, CDC Protocol 4-20 mA – Active current loop Audible Alarms Light Tower
Digital IO	Two remote switch inputs Eight outputs – 4.7 or 12 VDC configurable up to 800mA. current-sinking Darlington pair

Scale Controls and Operation



Fig. 1: Front Panel

Scale Annunciators

Unit of measure lb, oz, kg, g or lb:oz. The units annunciator to the right of the display will indicate the current unit of measure.

NET

Net weighing mode is indicated by the NET annunciator. The annunciator will illuminate when a net weight is displayed. When not illuminated, a gross weight is displayed.



Battery option status indicator. When the annunciator illuminates, the battery charge is low and the scale should be plugged in to recharge the battery. While the scale is charging, the battery annunciator will flash. When the charging is complete, the annunciator will turn off.



Center of zero. The annunciator will illuminate while the scale is displaying a zero weight.



Motion indicator. This symbol represents motion or instability of the weight. The annunciator will illuminate when motion is sensed on the platform. Changes in weight, vibration or air currents can cause the scale to go into motion.

1 to 8 setpoint output status indicators. Below the weight display are annunciators that are illuminated when an output is active in weighing mode or the current setpoint or preact is being edited.

Powering On

Connect the cord to a compatible power source.

For indicators with battery option, press and hold ZERO.

Basic Weighing Operation

- 1) Remove all items from the scale platform
- 2) Press the ZERO button to zero the scale
- 3) The weight display now reads zero
- 4) Place an item on the scale platform and wait for the motion annunciator to turn off, indicating an accurate, stable weight

ZERO

ZERO is used to zero the scale. To zero the scale, press the ZERO button. The scale will not zero if the scale is in motion. The zero function will operate over the entire capacity of the scale.

If the scale is displaying a net weight, pressing ZERO will return the scale to gross mode and display a zero weight. The stored tare will remain in memory.

The scale is equipped with a Zero on Demand parameter which zeros the scale upon the next stable reading after ZERO is pressed.

TARE

Place the item you wish to tare on the scale platform and press TARE. The scale will display a net weight and the NET annunciator will illuminate.

Tare weights will remain in memory even if the indicator is turned off.

Keyboard TARE entry

Enter a weight and press TARE to save or press CLEAR to cancel tare entry. The scale will display a net weight and the NET annunciator will illuminate.

Display TARE value

To display the current tare value, press and hold TARE for three seconds. The display will briefly read $\pm \bar{R} \bar{E}$ then flash the tare weight in the currently selected units. To exit press CLEAR.

Clear TARE value

Enter 0 and press TARE. This will remove the tare weight from memory.

GROSS NET selection

Press the GROSS NET button to switch between the gross and net weighing mode. Switching to the net mode is possible only when a tare is entered. Net mode is indicated when the NET annunciator is illuminated.

UNITS

UNITS selects the unit of measure. Press UNITS to change the current unit. The units annunciator to the right of the display will indicate the current unit or measure: lb, oz, kg, g or lb:oz.

Each unit can be enabled or disabled in the scale parameter setup. Lb:oz is disabled by default. Lb:oz is not available for checkweigh or setpoint values and cannot be transmitted as data.

PRINT

PRINT transmits data to a printer or other external devices. When the data is transmitted, the leftmost display digit will momentarily display an "r" to confirm data transmission.

There are many parameters that customize the control of manual and automatic transmission of data. Data can be transmitted via standard RS232, Ethernet, WiFi, Bluetooth or USB options. Contact Doran Tech Support at tech@doranscales.com for support.

START

Start currently loaded batch program.

STOP

Pauses or stops currently loaded batch program. Press once to pause and a second time to stop operation.

Password Protected Values

To activate password protection, the **PR55** parameter must be configured with a numeric password. Once configured, password protection will be activated upon power up.

If password protection is activated, the display will show **PR55** when Setpoint, Preact, Tare, values are displayed. Password protection also inhibits deletion or creation of new product IDs. Enter the password and press ENTER, the display will then show **PR55** and then **OFF**. Protection is now disabled and values can be accessed and changed.

To reactivate password protection, press and hold ENTER for 2 seconds. The display will show **PR55on**.

Setpoint and Output Operation

The 2200 is equipped with eight outputs and eight setpoints. The output must be assigned by the Output Configuration (**9.7 OUT**) parameter to any of the eight setpoints, remote input, batch program control and threshold weight to activate. A setpoint is a target weight that triggers an output. The method of triggering the assigned output is controlled by the configuration of the Setpoint Operation (**9.4 S.O.**) parameter.

Enter SETPOINT Target Weight

Press SETPOINT. The last viewed or edited setpoint will be displayed. Press UNITS or PRINT to scroll through the eight available setpoints. The annunciators below the main display indicate the current setpoint.

Enter the setpoint weight using the numeric keypad. Press SETPOINT to accept the change and return to the weigh mode or press UNITS or PRINT to save and edit other setpoints. Press SETPOINT to exit this mode.

The display will read **ABORT** to indicate no changes were made to the setpoint values or the display will read **SAVE** to indicate the setpoint value is saved.

Display SETPOINT Target Weight

Press SETPOINT. The last viewed or edited setpoint will be displayed. Press UNITS or PRINT to scroll through the eight available setpoints. The annunciators below the main display indicate the current setpoint. Press SETPOINT to exit this mode.

Setpoint Learning Preacts

A preact works with setpoints to allow the user to enter setpoint target weights that are the final desired weight. The preact automatically adjusts the setpoint target weight required for material in transit variations or line pressure changes. The output assigned to the setpoint will then transition before the setpoint target weight is achieved.

Note: Preacts are always adjusting the weight through the learning process. If the process has not changed, it should not be necessary to change this value. If the process is not reliably in control, change Preact Adjustment % Configuration (**9.6 PRE**) parameter to dial in the learning process. Use the password protection feature if adjustment of the preact could cause a safety issue.

Output Transition = Setpoint target weight – preact weight

The preact value changes based upon the final weight using the following formula:

Preact = previous preact + Adjustment % x (final stable weight – setpoint target weight)

The Preact Adjustment % Configuration (**9.6 PRE**) parameter affects how the learning preact will react to changes. The default value is 50% when the learning preact is turned on. The final stable weight sample will be collected within 3.5 seconds of the output transition. If no stable weight can be achieved in this time, the preact will not be adjusted for that measurement. The overall change will be limited to a maximum of 63% of the setpoint value, regardless of the adjustment percentage.

For Example:

20 pounds of a material is desired and material in transit is observed and estimated at 0.5 lb.

Setpoint 1 is set to 20 lb

Preact 1 is set to 0.5 lb

Adjustment % is left at the default of 50%

After running the process, the final weight is observed to be 20.3 lb

$\text{Preact} = 0.5 \text{ lb} + 0.5 \times (20.3 - 20)$

Preact = 0.65 lb

Enter Setpoint Preact Weight

Press SETPOINT. The last viewed or edited setpoint will be displayed. Press ZERO to display the preact weight. Press UNITS or PRINT to scroll through the eight available preacts. The annunciators below the main display indicate the current setpoint. Input the desired preact weight, then press ENTER. Press SETPOINT to exit this mode.

Display Setpoint Preact Weight

Press SETPOINT. The last viewed or edited setpoint will be displayed. Press ZERO to display the preact weight. Press UNITS or PRINT to scroll through the eight available preacts. The annunciators below the main display indicate the current setpoint. Press SETPOINT to exit this mode.

Tank Level Maintenance Mode

The Tank Level Maintenance Mode (9.4 5.0.) maintains a level in a tank between two setpoint target weights. This allows the tank to be drained to a desired amount before being refilled to a maximum target weight. Setpoint 1 will be the low level of the tank, and setpoint 2 will be the high level. When the tank is drained to setpoint 1, the output turns ON and the tank will begin filling. When the tank fills up to setpoint 2, the output turns OFF and until the tank is once again drained to setpoint 1. The output has been represented graphically below.

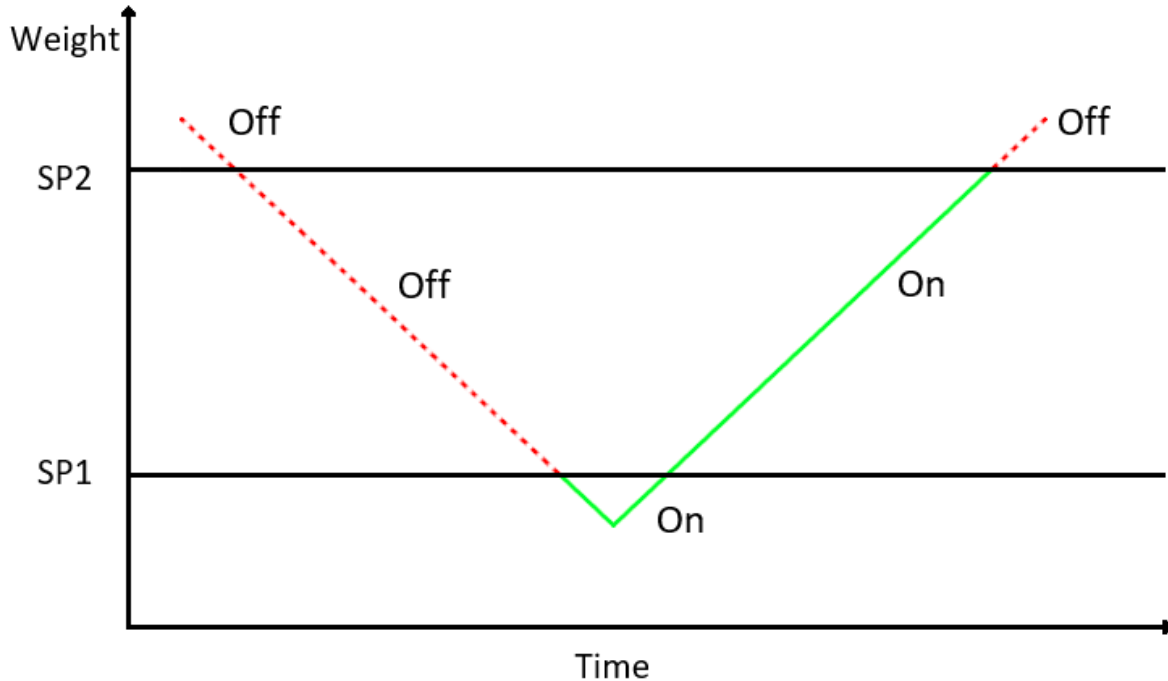

To configure this operation:

1. Setpoint 1 must be configured to 0FF in the Setpoint Operation (9.4 5.0.) parameter.
2. Setpoint 2 must be configured to F H in the Setpoint Operation (9.4 5.0.) parameter.
3. Assign setpoint 2 to an output in Output Operation (9.7 00t) parameter.
4. Enter setpoint 1 as the lowest weight desired, as described in the setpoint section of the manual.
5. Enter setpoint 2 as the highest weight desired, as described in the setpoint section of the manual.
6. Ensure Setpoint Weight Operation (9.5 500.) is configured to 05P for displayed weight.

Note: While F H is set to setpoint 2, the ZERO button is disabled

Battery Operation

The 2200 can be optionally configured with a self-contained Rechargeable Sealed Lead-Acid battery and charging circuit, both internal. The scale is designed to run continuously for up to 60 hours with a single 350 ohm load cell. To maximize battery life, leave the auto-off timer enabled which will automatically power down the scale after a period of non-use.

Power Off

- 1) Manual - Press and hold the ZERO push button until the display turns off. The scale will not turn off if plugged in but will instead display “r E L P b”.
- 2) Automatic - At the end of the Unit On Timer (2.4 t d y) scale parameter setting. The scale will not turn off if plugged in.

Low Battery Indication



The battery annunciator indicates that the battery is in need of recharging. Once it turns on, there will be approximately one hour of battery life remaining before the scale turns off. Multiple load cells, USB, Bluetooth, Ethernet, 4-20mA and WiFi communications will reduce battery life.

Recharging Battery

To charge the battery, plug the line cord into a wall outlet. While the scale is charging, the battery annunciator will flash. The charging circuit will fully charge the battery in approximately eight hours. When the charging is complete, the annunciator will turn off. The scale can be used while recharging the battery.

Leaving the scale plugged in will ensure a fully charged battery and will not affect the life of the battery. The battery is able to support up to 1000 recharges. This is an estimate as many factors can affect battery life, including severe temperature changes and charging before the scale displays low battery.

Product ID

800 product IDs are available. Deploying a large library of IDs with multiple scales can be easy to manage with Doran's data management programs.

Product IDs save information that includes:

- Setpoint values
- Preact values
- Batch program assigned to product ID
- Unit of measure
- Accumulator and counter values
- Tare
- Two 40 alphanumeric character fields
- Motion Aperture (1.6 mm.R.)
- Threshold (2.5 tH5)
- Setpoint operation (9.4 5.0.)
- Output configuration (9.7 out)

Recall PRODUCT ID from Memory

When powered on, no product ID will be loaded. This is indicated when pressing PROD ID and the display reads 000. Once a product ID is loaded, the unit of measure is locked in the unit of the product ID.

To select a stored product, press PROD ID, enter the ID number and press ENTER. The display will read 5RUEd to indicate the fields associated with that Product ID number are active. After selecting a product, the scale will measure and display in the units saved for that product. The UNITS button will then be disabled. Selecting product 'OFF' will re-enable the UNITS button.

Another method to select a product is to press PROD ID, then use the UNITS or PRINT buttons to scroll through the available products. Press ENTER to select the displayed product. The display will read 5RUEd to indicate the fields associated with that Product ID number are active.

Barcode Scan Recall PRODUCT ID from Memory

Press PROD ID to enter the Product ID recall mode. The display will show 1d, followed by the current Product ID number. Using Doran's optional barcode scanner, scan the desired barcode. The display will confirm by showing the barcode value. To exit the ID edit mode, press PROD ID.

Display Current PRODUCT ID

Press PROD ID, the display will show 1d followed by the currently active product.

Create New PRODUCT ID

Select the desired unit that will be used to checkweigh the new product. Enter a product ID up to 6 digits not currently in memory and press PROD ID. The display will momentarily show nEuu then 1d. Then return to weighing mode. All fields associated with the new Product ID number will be blank.

To enter and save values for all fields associated with the current Product ID, enter values for each field. When changing products, the display will read **SAVED** to indicate that all fields associated with the new Product ID number are saved and will be recalled when that product is used again.

Delete PRODUCT ID from Memory

Enter the product ID to be deleted and press PROD ID. The display will show **Prod ID**, followed by the Product ID number. Press and hold the CLEAR button for more than 2 seconds. The display will show **Clear ID** and then **done**. All fields associated with that Product ID number will be cleared. The previously used Product ID number will become active.

Product Fields

The 2200 has eight 40-character alphanumeric fields that can be entered and transmitted as desired using custom data strings. In addition, there is a ninth product for serialization which increments from the five digit number entered. This is useful for custom data labels and data collection.

Display Product Fields

To access Product Fields, press and hold PROD ID on the front panel for 3 seconds. The display will show "PF 1" for a second, then display the first 6 characters of the product field if they are numeric. The eight fields can be cycled through by pressing ENTER. Press PROD ID to exit from the Product Field mode.

Product Field Entry

To access Product Fields, press and hold PROD ID on the front panel. After 3 seconds, the scale display will change from the current platform weight to show which Product Field is ready for entry. For the first field, the display will show "PF 1" for a second, then display the current entry of this field.

Product Fields can be entered by barcode, by external communications, or by the keypad on the front panel. When the indicator receives a barcode scanner transmission completed by a carriage return it will accept the scanned field automatically when the field number is active. If the scanned item is alphanumeric only, press enter to accept the scanned field. A keypad entry followed by pressing ENTER, will store the entered value as that Product Field. Once entered, the scale will then display the next Product Field, in this case "PF 2". The scale will cycle through the 9 Product Fields unless the user presses PROD ID again, which will exit from the Product Field mode.

Batch Program Operation

A batch program uses a series of commands to operate a control process. Operating Mode (**1**, **1?**, **oP**) must be set to batch operating mode for batch programs to run. Up to 100 programs can be stored at one time. Each program can contain up to 100 commands.

Load a Batch Program into Memory

If the unit is programmed with multiple batch programs, they are selected by recalling a Product ID that contains many parameters that affect the operation of the batch program. Reference the Product ID section for more information.

If only one batch program is stored in memory, a Product ID is not required but still can be used if desired.

If a single batch is used with no Product ID, the batch program is loaded when the indicator powers on.

Start a Batch Program

Pressing start begins the batch program.

Pause a Running Batch Program

Press STOP once to pause the batch program.

Press START to resume the batch program.

Stop a Running Batch Program

Press STOP twice to stop and reset the batch program to the first step.

Batch Commands

Command	Description
START	START button press required. Use to pause a batch that requires user interaction.
TARE	Performs a TARE operation
ZERO	Performs a ZERO operation
PRINT	Performs a PRINT operation
NET	Places the indicator in NET mode Note: Setpoint Weight Operation (9.5 5uu.) setting controls setpoint target weight and the net weight may not be the setpoint target weight.
GROSS	Places the indicator in GROSS mode Note: Setpoint Weight Operation (9.5 5uu.) setting controls setpoint target weight and the net weight may not be the setpoint target weight.
ACCUM	Performs a Accumulation operation
ACCUM / CLEAR	Clears Accumulator and counter values
Set Output X	Will activate output 1-8 where X is the output number. Only operates on outputs with Output Configuration (9.7 ouk) parameter set to 68k
Set Output All	Will activate all outputs. Only operates on outputs with Output Configuration (9.7 ouk) parameter set to 68k
Deactivate Output X	Will deactivate output 1-8 where X is the output number. Only operates on outputs with Output Configuration (9.5 ouk) parameter set to 68k
Deactivate Output All	Will deactivate all outputs. Only operates on outputs with Output Configuration (9.5 ouk) parameter set to 68k
Wait for Setpoint X	Waits for Setpoint 1-8 to transition states
Wait for Input 1	Pauses until Input 1 is active
Wait for Input 2	Pauses until Input 2 is active
Wait 001-999 seconds	Pauses for up to 999 seconds

Wait Until Stable	Halts further operations until a stable weight is achieved
Wait for Product ID	Pauses until a valid product ID is entered
Wait for Keypad Tare Entry	Operator enters a valid tare value and presses enter
Global Repeat	Repeats the operations infinitely
Global Repeat 01-99	Repeats operations up to 99 times
Start of local repeat	Repeats steps between this command and the local repeat command below
Local repeat 01-99	Performs a repeat of commands between this step and the Start of local repeat command up to 99 times
Start of Input Jump	Line jumped to based upon Input X active Jump command
If Input 1 Active Jump	Performs a line jump command if Input 1 is active
If Input 2 Active Jump	Performs a line jump command if Input 2 is active
End of Batch	Batch program ends

Time and Date

Setting Time and Date

Press and hold decimal point / clock button until $\text{d}^{\text{R}}\text{t}^{\text{E}}$ is displayed. The current date flashes on the display. To toggle between the current time and date, press the decimal point button. The display reads $\text{t}^{\text{R}}\text{t}^{\text{E}}$ when the time is displayed.

To change the date:

1. Press and hold decimal point / clock button until $\text{d}^{\text{R}}\text{t}^{\text{E}}$ is displayed
2. The display flashes the current the date
3. The digit being edited flashes on the display
4. Enter the date with leading zeros in the format MM.DD.YY
5. Press UNITS to advance to the next digit
6. Press UNITS until the display reads $\text{t}^{\text{R}}\text{t}^{\text{E}}$ to confirm the date changes are saved

To change the time:

1. Press and hold decimal point / clock button until $\text{d}^{\text{R}}\text{t}^{\text{E}}$ is displayed
2. Press the decimal point button
3. The display reads $\text{t}^{\text{R}}\text{t}^{\text{E}}$ when the time in 24 hour format is displayed
4. The digit that being edited flashes on the display
5. Enter the time with leading zeros in the format HH.MM.SS
6. Press UNITS to advance to the next digit
7. Press UNITS until the display reads $\text{t}^{\text{R}}\text{t}^{\text{E}}$ to confirm the time changes are saved

Press ENTER to return to the normal weighing mode.

Accumulator and Counter

Accumulator and Counter Operation

When a manual or automatic print function is executed, the accumulator has the currently displayed weight added to its current value and the counter is incremented. To confirm an accumulation and counter operation, the left most display digit will momentarily display an \square .

To accumulate automatically, select an auto print function in the parameter setup menu.

To accumulate manually, allow the scale to become stable and press PRINT.

The maximum value that can be shown for the accumulator and counter is 999,999. When the maximum value is reached, the accumulator and counter will rollover to a zero value. This feature can only be used in a non Legal For Trade application.

If using Product ID functions, the Accumulator and Counter values are stored with the associated product.

Display Accumulator and Counter Values

Press the ACCUM button to enter the accumulator and counter recall mode. The display will show \square followed by the accumulated weight in the units currently selected in the weigh mode. Then \square will be displayed followed by the counter value.

Press ACCUM to exit the accumulator and counter recall mode without changing their values.

Clear Accumulator and Counter

Press the ACCUM button to enter the accumulator and counter recall mode. The display will show \square followed by the accumulated weight in the units currently selected in the weigh mode. Then \square will be displayed followed by the counter value.

Press CLEAR to clear the accumulator and counter values. The display will show \square and exit from the recall mode.

Changing the current display units will clear both the accumulator and counter values.

Accumulator and Counter Data String Output to Printer or Data Collection

Press ACCUM to enter the accumulator recall mode. Press PRINT to transmit the LB4 custom data string that contains the accumulator and counter values by default. Both the accumulator and counter values are cleared after transmission.

Installation Guide

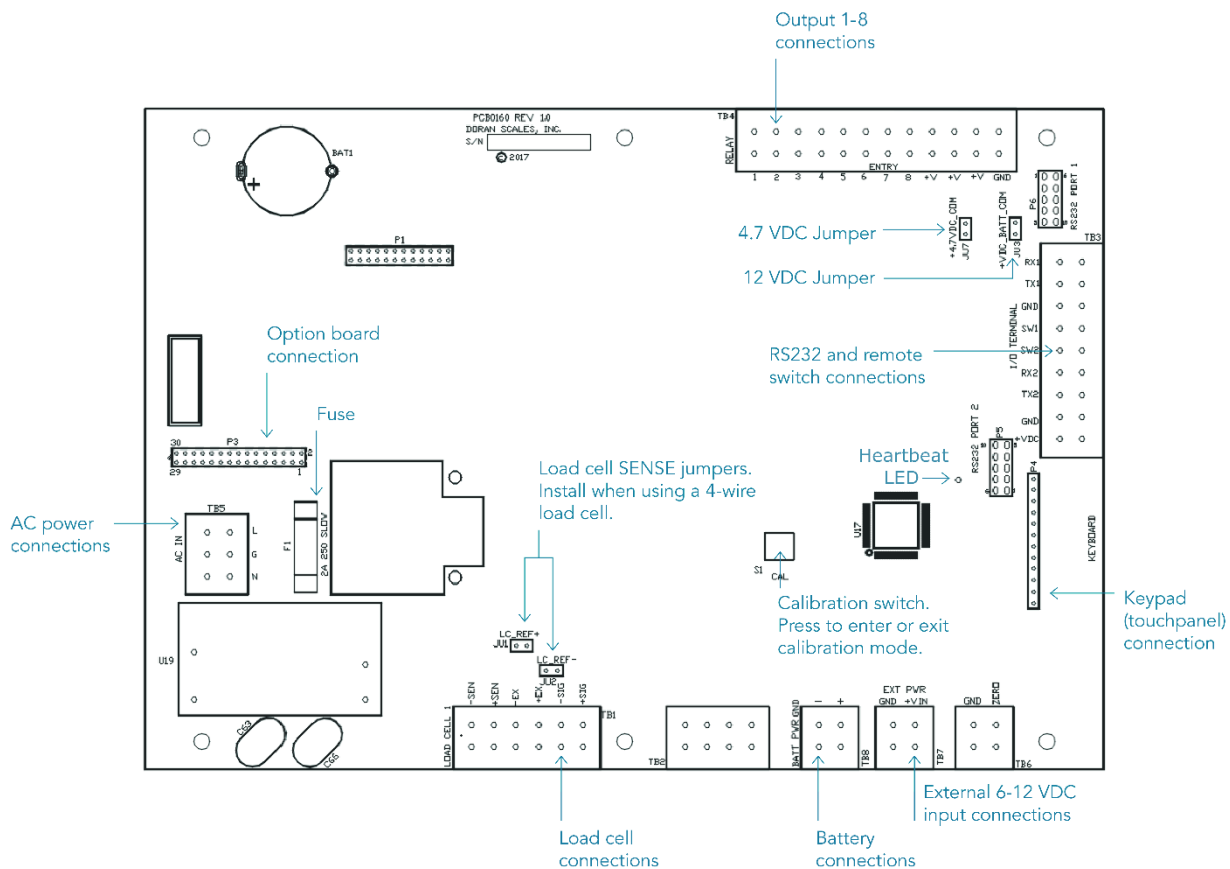

Fig. 2: Motherboard Layout

Removing and Replacing the Rear Panel

Before you remove the rear panel, remove AC power. Power down the scale if the optional battery power is present. Removing the rear panel requires a 5/16" nut driver.

To replace the rear panel and achieve a tight seal, each screw requires a rubber bonded washer and the gasket needs to be in place. Tighten screws to 20 in-lb to achieve proper sealing. Tighten all watertight glands until the cable exiting the watertight can no longer slide through the watertight – this is usually finger tight plus a quarter turn with a wrench to seal.

Heartbeat LED

Between the keypad connection and the microprocessor exists a green heartbeat LED. When this LED is blinking, it indicates that the microprocessor has successfully loaded software and is receiving power.

Load Cell Connection

Load cell connections are made through terminal block TB1. The power cord connects to terminal block TB5 adjacent to the transformer.

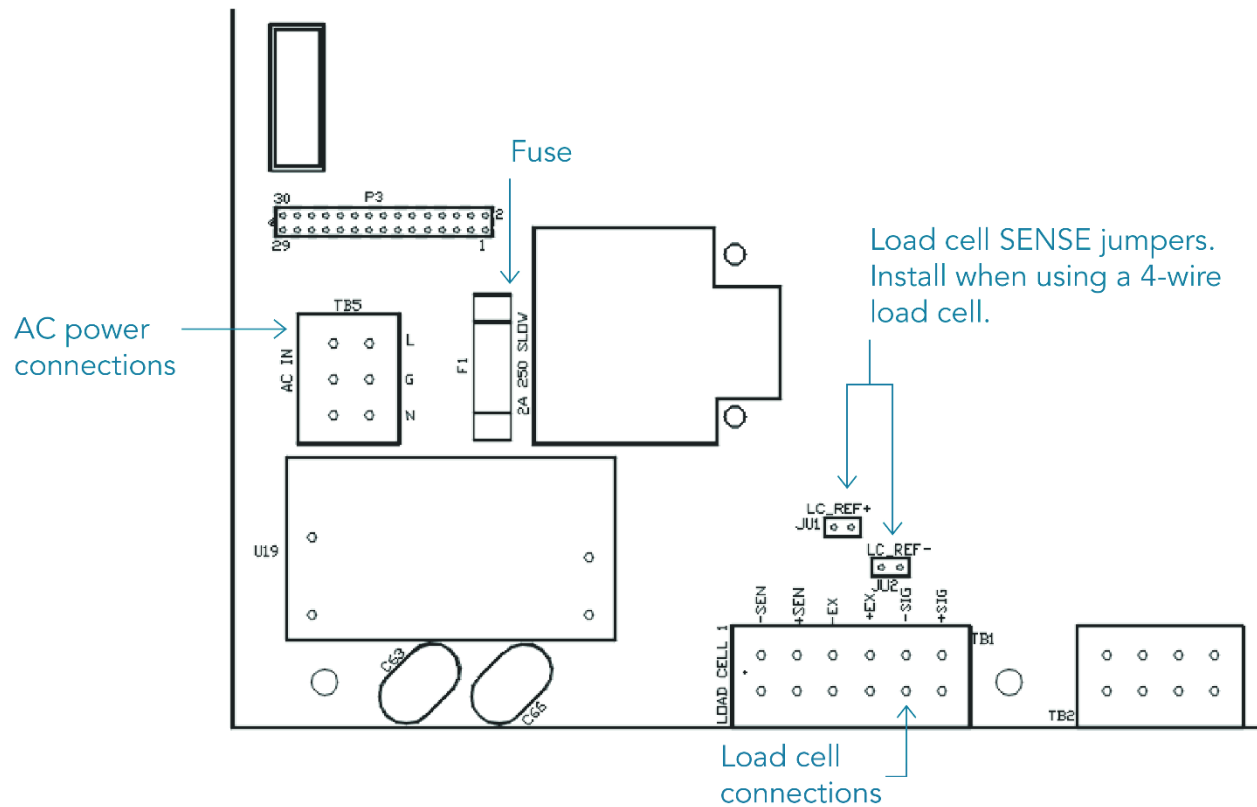

Fig. 3: Load Cell and Power (lower left of board)

	4 wire load cell	6 wire load cell
J1 Jumper	In	Out
J2 Jumper	In	Out

Load Cell Input (TB1)		
	Description	Load Cell Color Code
+ SIG	+ Signal	Red
- SIG	- Signal	White
+ EX	+ Excitation	Green
- EX	- Excitation	Black
+ SEN	+ Sense Signal	Blue
- SEN	- Sense Signal	Brown

Power Connection and Fuse

Power input is located at terminal block TB5, next to the fuse and black transformer.

Neutral	Ground	Line (Hot)
N	G	L

Make sure power is off before replacing the fuse. The scale's fuse (F1) is located next to the power terminal (J1).

The scale has a filtered power supply to reduce the effects of normal line noise, but it cannot limit severe fluctuations. Be sure the AC power is not excessively noisy. If problems occur, noise producing devices may have to be suppressed to minimize their effect.

RS232 and Remote Switch Connection

The Remote Switch and Serial Communications are located in the TB3 terminal block. Option cables are passed through watertight glands mounted on the rear cover of the indicator.

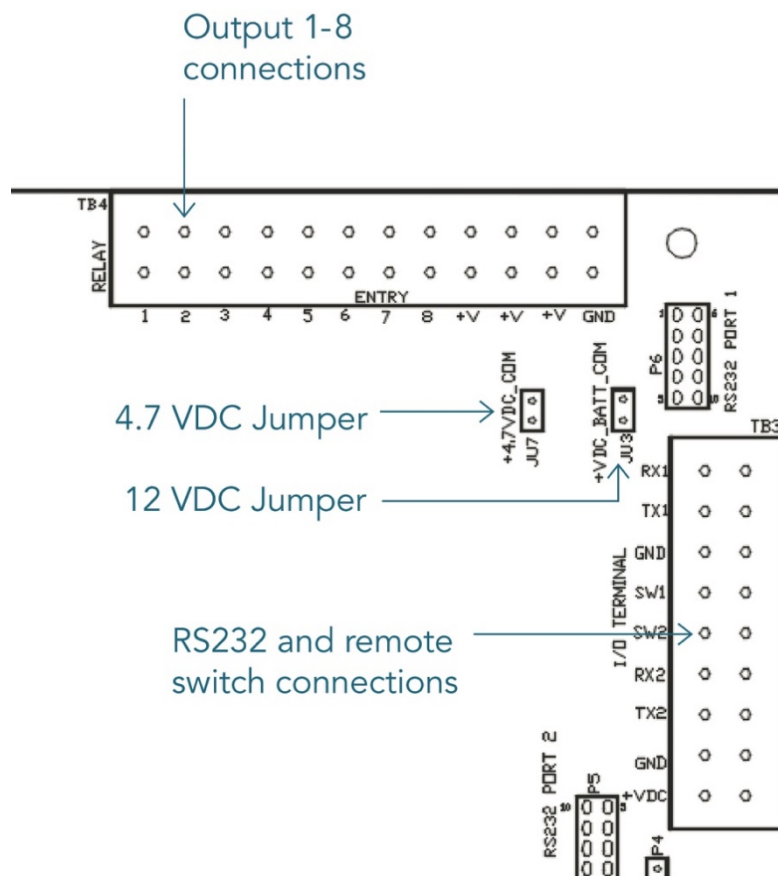

Fig. 4: Output Serial and Remote Switch Connection (upper right of board)

TB3 RS232 and Remote Switch Connections	
	Description
RX1	RS232 Port 1 Receive (RXD)
TX1	RS232 Port 1 Transmit (TXD)
GND	Common Ground
SW1	Remote Switch 1 Input
SW2	Remote Switch 2 Input
RX2	RS232 Port 2 Receive (RXD)
TX2	RS232 Port 2 Transmit (TXD)
GND	Remote Switch Common
VDC	4.7Vdc

RS232 Output DB9 Female Connector Wiring		RS232 Output DB9 Male Pin Wiring	
Female Description		Male Description	
2	(TXD) Transmitted Data	(RXD) Received Data	
3	(RXD) Received Data	(TXD) Transmitted Data	
5	(GND) Ground	(GND) Ground	

Output Connections

Each output point consists of a current-sinking Darlington pair with a transient – suppression diode connected to +V. Jumpers JU7 and JU3 control whether +V is board-supplied 4.7 VDC or 12 VDC. One or the other jumper needs to be installed for output operation, but never both. The maximum current sinkable through a single output is 500mA. If using board-supplied voltage, the maximum total current available is 800 mA.

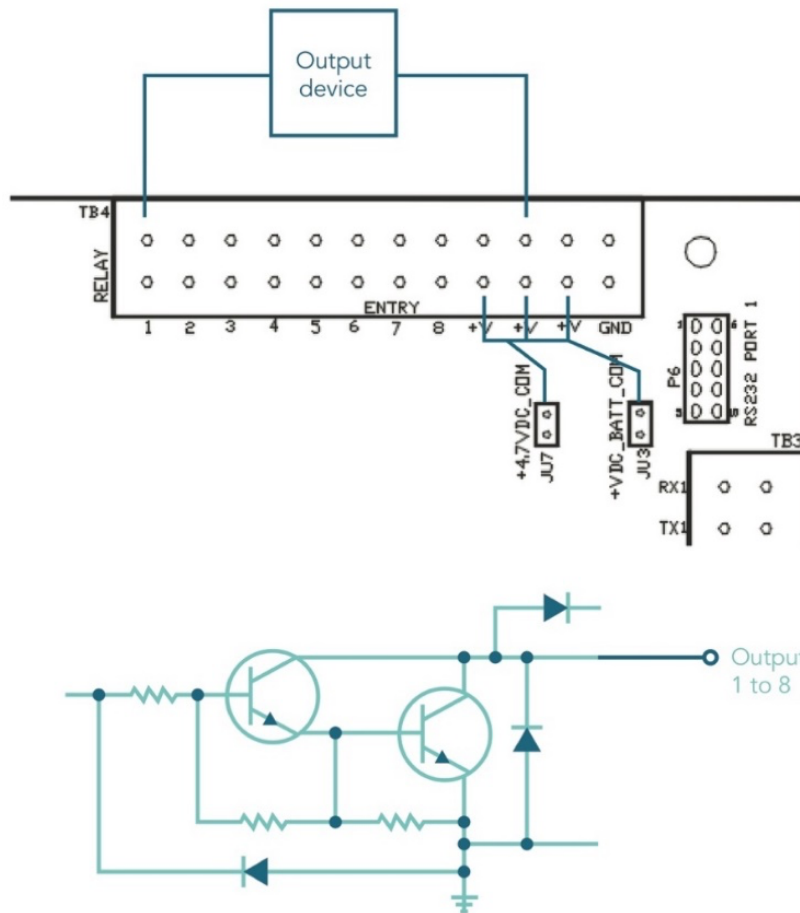

Calibration Guide

Entering Calibration and Parameter Setup Mode

Front Panel Access

1. Press and hold ZERO and UNITS simultaneously until the audit counters are displayed.
2. $\bar{E}n\bar{t}$ $\bar{C}d$ is displayed
3. Press ZERO 5 times, so that \bar{E} is displayed,
4. Press UNITS

Internal Calibration Button

The calibration push button is located near the center of the board and labeled CAL. Press this button to enter calibration and setup.

Exit Calibration and Parameter Setup Mode

Front Panel Access

1. Press UNITS until the display reads $\bar{C}d$. $\bar{E}n$.
2. Press the ZERO button
3. The display reads $\bar{C}d\bar{E}n$
4. Press the ZERO button
5. The display reads $\bar{C}d\bar{E}n\bar{E}$
6. Press UNITS to return to the run mode
7. Display reads $\bar{E}n\bar{E}n\bar{E}n$ to confirm changes are saved to memory

Internal Calibration Button

The calibration push button is located near the center of the board and labeled CAL. Press this button to exit calibration and save settings.

Set Scale Capacity

The Capacity selection is displayed after entering the Calibration and Setup mode.

1. $\bar{C}d\bar{E}n$ is displayed
2. Press ZERO
3. The display will alternate between $\bar{C}d\bar{E}n$ $\bar{R}d$ and the currently selected capacity
4. Press ZERO to change the capacity
5. The units annunciator will flash indicating the unit of measure for the capacity. Press ZERO to change the unit of measure if required.
6. Press PRINT
7. The right most digit will flash. Press ZERO to change this number from $\bar{0}$ to $\bar{9}$.
8. Press PRINT to move to the next digit to the left.
9. Repeat until all digits have been set to the desired scale capacity.
10. Once the digits have been set, the display will return to alternately displaying $\bar{C}d\bar{E}n$ $\bar{R}d$ and the new capacity value.

Set Scale Count By

After the capacity has been entered, count by(resolution) will automatically be set for a legal for trade 5000 division level.

1. After calibration, press UNITS.
2. The display will alternate between $\overline{C}nt$ and the current count by
3. Press ZERO to select the desired count by
4. To exit and save changes, press UNITS until $\overline{C}nt$ is displayed.
5. Press ZERO
6. $\overline{C}nt$ will be displayed
7. Press UNITS to return to the run mode

Calibration

After count by has been set, calibration is required

1. Press UNITS until \overline{CAL} appears on the display
2. Remove all weight from the scale platform
3. Press ZERO and wait for the display to count down to 0
4. The display will alternate between \overline{CAL} and the scale capacity
5. Place the calibration weight on the scale platform (2% of capacity to full capacity)
6. If calibrating at scale capacity, press ZERO to begin calibration and move to step 12. If not calibrating at the scale capacity, continue to step 7.
7. Press PRINT
8. The right most digit will flash. Press ZERO to change this number from 0 to 9.
9. Press PRINT to move to the next digit to the left
10. Repeat until all digits have been set to the desired calibration weight
11. Press PRINT and the calibration process will begin and the display will count down to zero.
12. The display will momentarily display \overline{CAL} , followed by \overline{SPAN} and return to the normal weighing mode
13. Verify scale calibration

NOTE: Calibration at 2% of capacity has been provided as a convenience to customers with scales in inaccessible locations. Scales calibrated at 2% will not be as accurate at full capacity compared to scales calibrated at full capacity. It is the responsibility of the installer to ensure that scale accuracy is achieved after any calibration.

Calibration Messages	
Code	Solution
\overline{CAL}	The calibration zero is out of range. Press ZERO to clear error. Refer to the Scale Calibration Error Troubleshooting section.
\overline{SPAN}	The calibration span is in a negative range. Check polarity of load cell connection and repeat calibration.
\overline{SPAN}	The calibration span is out of range. Press ZERO to clear this error. Refer to the Scale Calibration Error Troubleshooting section.
\overline{CAL}	The scale is sensing an unstable weight. Remove any vibration or air currents to continue calibration.

Scale Calibration Troubleshooting

The allowable load cell signal input range is 0.30 mV/V to 5.0 mV/V.

1. Calculate scale divisions by dividing the scale capacity by the count by. Example:
For a 50 x 0.01 lb scale, divide 50 by 0.01 for a result of 5000d
2. Enter the calibration and parameter setup mode.
3. Press PRINT until the configuration menu $\overline{\text{CAL}} \overline{\text{F9}}$ is displayed.
4. Press ZERO to enter the configuration menu.
5. Press UNITS until the scale counts are displayed.
6. Remove all items from the platform and record the zero load scale counts reading.
7. Place full capacity on the platform and record the scale counts.
8. Subtract the zero load counts from the full load counts to calculate the span.
9. The span number, from step #7, must be higher than the scale divisions found in step #1.

The maximum span, at full load is 750,000. If the span is higher, the span calibration will not be accepted.

If the span counts are too low or too high, check the load cell connections. If the connections are correct, replace the load cell.

Scale Parameter Setup

Entering Calibration and Parameter Setup Mode

Front Panel Access

1. Press and hold ZERO and UNITS simultaneously until the audit counters are displayed.
2. ୧୩୧ ୯୯ is displayed
3. Press ZERO 5 times, so that ୫ is displayed,
4. Press UNITS

Internal Calibration Button

The calibration push button is located near the center of the board and labeled CAL. Press this button to enter calibration and setup.

Exit Calibration and Parameter Setup Mode

Front Panel Access

1. Press UNITS until the display reads ୨୨. ୯୯୩.
2. Press the ZERO button
3. The display reads ୯୯୩୧୩
4. Press the ZERO button
5. The display reads ୯୯୩୧୫
6. Press UNITS to return to the run mode
7. Display reads ୫୩୫୧୯ to confirm changes are saved to memory

Internal Calibration Button

The calibration push button is located near the center of the board and labeled CAL. Press the button to exit calibration and save settings.

Navigating Parameter Menu with Keypad

To navigate to a specific parameter, first enter calibration and parameter setup mode, as described above. Then, enter the parameter group number, a decimal point, and the element number, followed by the ENTER button. These values are located to the left of each parameter outlined later.

Navigating Parameter Menu with ZERO, UNITS, and PRINT

Press UNITS and PRINT navigate to the desired top level parameter group. Enter the group by pressing ZERO. Once within a group, press UNITS to advance, PRINT to back up and ZERO to change the currently displayed parameter setting.

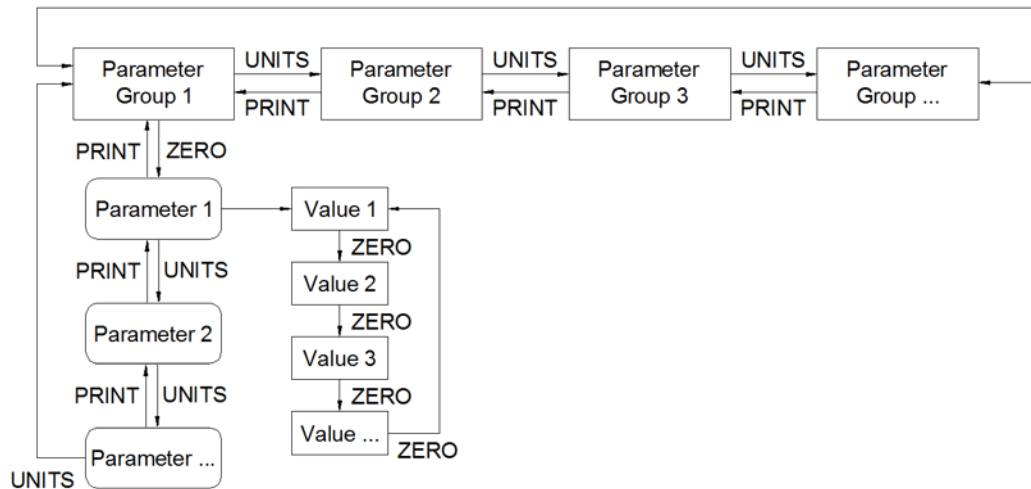

Parameter Groups

The scale parameters are divided up into eight parameter groups. Each group contains related parameters. Below is a brief list describing each parameter group.

1 CAL	Capacity and Calibration
2 CONF	General Settings
3 SER1	Serial port #1
4 SER2	Serial port #2
5 ETH	Ethernet
6 WIF	Wireless Ethernet
7 BT	Bluetooth
8 USB	USB
9 OPER	Output Operation
99 DON	Exit Setup

Legal for Trade Restrictions

When the Legal for Trade mode is enabled, it automatically disables some menus and parameter options. This is done to comply with NTEP and CWM requirements. The menus and parameter sections are shown on the following pages. Menus and parameters not available when in the Legal for Trade mode are marked by an asterisk.

Audit Counters

When entering calibration mode, the Parameter audit counter and the Calibration audit counter will momentarily be displayed. The Parameter audit counter increments when legal for trade values are changed. The Calibration audit counter increments when the scale is calibrated.

Software Part Number and Revision Level

During the front panel access procedure, the scale will display the software number and revision. The software number is 5.0 1.0 followed by the software revision level r 5.0.

Please have the software number 5.0 1.0 and the revision level available when contacting our technical support department.

Capacity and Calibration - 1 [RL]

1.1	[RP RJ]	Capacity Adjustment
	1 - 999000	1 lb / kg to 999,000 lb / kg Refer to calibration guide for more detail

1.2	[ntby]	Count By Setup Menu Also known as resolution or division
	0.00002 5000	Selection limited by scale capacity Capacity/resolution (scale divisions) maximum value is 50,000d and minimum value is 200d

1.3	[RL]	Calibration Mode
	0	Calibration Zero Press ZERO to perform calibration of the scale zero Successful calibration is indicated by "[RL FS]"
	XXXXXX	Only appears after a successful zero calibration Enter calibration weight through keypad and decimal point if required.

1.4	RJ9	Display Filter Setting Determines speed of digital filtering
	1	Fastest display updates, most sensitive setting
	2	Default Setting
	4	
	8	
	16	
	32	
	64	Slowest display updates, least sensitive setting

1.5	RZt*	Automatic Zero Tracking Range Weight within the specified number of divisions are automatically zeroed
	oFF	Zero tracking is off, no automatic zeroing
	0.5	Zero tracking to within 0.5 division
	1*	Zero tracking to within 1 division
	3*	Zero tracking to within 3 divisions
	5*	Zero tracking to within 5 divisions
	10*	Zero tracking to within 10 divisions
	20*	Zero tracking to within 20 divisions

1.6	nn.R.*	Motion aperture* Determines the number of divisions that consecutive readings must change before the scale is considered to be in motion
	0.5*	0.5 divisions
	1	1 division
	2*	2 divisions
	3*	3 divisions
	5*	5 divisions
	10*	10 divisions

1.7	nn.d*	Motion Delay* Length of a motion indication display.
	1 - 9	Length of a motion indication display, in 100ms intervals. Default is 3 . (Locked to 3 in Legal for Trade mode)

1.8	SV0*	Start Up Zero Controls the zero point when the scale is turned on
	oN	Zeros on the first stable reading on power up
	CL0	Loads the calibration zero point
	Pb0*	Loads the last pushbutton zero

1.9	tRr	Tare Input
	Pbn	Tare Pushbutton as well as keypad entry
	Pb	Tare Pushbutton only
	n	Keypad only
	oFF	No tare entry

*Parameters not available in Legal for Trade mode

1.10	Zod	Zero on Demand Enables or disable zero latching
	on	If ZERO is pressed, it is saved until the scale becomes stable.
	off	If the scale is in motion, the zero request is discarded.

1.11	Pod	Print on Demand Enables or disables print latching
	on	If PRINT is pressed, the print request is saved until the scale becomes stable.
	off	If the scale is in motion, the print request is discarded.
	not	Print when requested, whether the scale is in motion or not

1.12	oP	Operating Mode
	Std	Standard operation
	44	NTEP legal-for-trade. Restricts parameters to keep them within NTEP limits.
	445	CWM legal-for-trade. Restricts parameters to keep them within CWM limits.
	bat	Batch program mode. In this mode, ZERO and TARE buttons are disabled.

1.13	bat	Batch Selection
	00-99	Select batch number that will be loaded into memory if no product ID is loaded. 00 = no batch selected

1.14	donE	Exit Calibration and Setup
	y	Saves and exits setup when PRINT or UNITS is pressed.
	n	Remains in setup

General Settings - 2 [nF9]

2.1	[5L	Unit Enable and Disable Determines which unit selections will be active
	no	Do not enter Convert selection menu
	YES	Enter Convert selection menu
	[b	pounds menu
	on	lb is active
	off	lb is non active
	kg	kilograms menu
	on	kg is active
	off	kg is non active
	oz	ounces menu
	on	oz is active
	off	oz is non active
	gr	grams menu
	on	g is active
	off	g is non active
[o	pound:ounce menu	
on	lb:oz is active	
off	lb:oz is non active	

NOTE: oz units are disabled for capacities greater than 60,000 lb
grams units are disabled for capacities greater than 2000 lb
lb:oz are only available for capacities between 10 and 1000 lb

2.2	[un t5	Start Up Units Select Mode Configures selection of startup units
		The unit annunciator, to the right of the display, indicates the active unit on power up. Press ZERO to change the selection.

2.3	P.b.	Push Button Enable and Disable Determines which buttons are active or inactive	
	no	Do not enter push button selection menu	
	yes	Enter push button selection menu	
	P_r	PRINT button	
		on	pb is active
		off	pb is non active
	U_t	UNITS button	
		on	pb is active
		off	pb is non active
	Z_r	ZERO button	
		on	pb is active
		off	pb is non active
	r 1, r 2	REMOTE SWITCH 1 and 2 function	
		off	Remote pb is non active
		Z _r	ZERO
		P _r	PRINT
		U _t	UNITS
		A _c	ACCUM
		T _r	TARE
		G _n	GROSS NET
		S _A T	START
		S _O P	STOP
	S_t	Start and Stop buttons	
		on	pb is active
		off	pb is not active
	G_n	GROSS NET button	
		on	pb is active
		off	pb is not active
	A_c	ACCUM button	
		on	pb is active
		off	pb is not active (disables accumulator function)
	S_P	SETPOINT button	
		on	pb is active
		off	pb is non active
	T_r	TARE button	
	on	pb is active	
	off	pb is non active	
i_d	PRODUCT ID button		
	on	pb is active	
	off	pb is non active	

2.4	ቴሪሃ	Automatic off Timer Only visible when ቴሸሎት parameter is set to ሃ
	፩	Unit will remain on, On timer is off
	0.5	30 second On timer
	1	1 minute On timer
	1.5	1.5 minute On timer
	2	2 minute On timer
	3	3 minute On timer
	5	5 minute On timer
	10	10 minute On timer
	30	30 minute On timer
	1hr	1 hour On timer
	2hr	2 hour On timer
	4hr	4 hour On timer
	8hr	8 hour On timer

2.5	ቴዛና	Threshold Level Entry Controls some printing features, setpoints, and outputs
	0.1 - 9.9	$\pm 0.1\%$ to $\pm 9.9\%$ of capacity Default setting is 1%

2.6	ፈፂፂት	Default Used to set parameters to factory default values
	፩	Do not default
	ሃ	Set parameters to default values

2.7	Counts	Raw counts from the AD converter Used for troubleshooting during calibration
	xxxxxx	-99999 to 999999

2.8	ጥገት	Controls the brightness of all LEDs
	1- 15	Can be set to a value of 1 to 15 with 15 being the brightest. Default value is 9 . Note: Decreasing brightness conserves battery life.

2.9	ቴሸሎት	Enable or disable battery operation
	፩	Battery option not installed
	ሃ	Battery option installed

2.10	PR55	Enable or disable password
	n	Password inactive
	y	Password active – press UNITS, enter numeric password and press ENTER. The password must be a minimum of 3 digits and no longer than 6 digits.

Serial (RS232) Port 1 - 3 5Er :

3.1	d.o. :	Data Output Mode Port 1
	t.o.d.	Transmit on demand. Transmit when the PRINT button is pressed.
	A.P.1	Auto Print 1. Transmit once only when scale becomes stable.
	A.P.2	Auto Print 2. Transmit once only when scale becomes stable. Scale must return to, or below, the threshold range (2.5 tH5).
	A.P.4	Auto Print 4. Transmit first stable weight outside of threshold. Transmission happens when weight returns to threshold range (2.5 tH5).
	A.P.5	Auto Print 5. Transmit the last stable weight outside of threshold. Transmission happens when weight returns to threshold range (2.5 tH5).
	t1	Transmits every 1 second.
	t5	Transmits every 5 seconds.
	t60	Transmits every 60 seconds.
	C.P.	Continuous Print. Transmit when display is updated. Approximately every 1/10 th of a second.
	oFF	Port disabled

Note: only one communication port can have a timed output mode (t1, t5, t60, or CP)

3.2	For. :	Data Output Format Port 1
	F0	Basic output format
	2d	Basic Dual Print Format. Includes Kilogram weight.
	55P	Basic Output for label printer
	F9	Model 8000 emulation
	Lb1	User definable print string with default values
	Lb2	User definable print string with default values
	Lb3	User definable print string with default values
	Lb4	User definable print string
	ba	WinSPC compatibility format

3.3	br. 1	Baud Rate Port 1
	12	1200 baud
	24	2400 baud
	48	4800 baud
	96	9600 baud
	14.4	14,400 baud
	19.2	19,200 baud
	28.8	28,800 baud
	38.4	38,400 baud

Serial (RS232) Port 2 - 4 5Er2

4.1	d.o. 2	Data Output Mode Port 2
	t.o.d.	Transmit on demand. Transmit when the PRINT button is pressed.
	A.P. 1	Auto Print 1. Transmit once only when scale becomes stable.
	A.P. 2	Auto Print 2. Transmit once only when scale becomes stable. Scale must return to, or below, the threshold range (2.5 tH5).
	A.P. 4	Auto Print 4. Transmit first stable weight outside of threshold. Transmission happens when weight returns to threshold range (2.5 tH5).
	A.P. 5	Auto Print 5. Transmit the last stable weight outside of threshold. Transmission happens when weight returns to threshold range (2.5 tH5).
	t1	Transmits every 1 second.
	t5	Transmits every 5 seconds.
	t60	Transmits every 60 seconds.
	C.P.	Continuous Print. Transmit when display is updated. Approximately every 1/10 th of a second.
	oFF	Port disabled

Note: only one communication port can have a timed output mode (t1, t5, t60, or CP)

4.2	For. 2	Data Output Format Port 2
	F0	Basic output format
	2d	Basic Dual Print Format. Includes Kilogram weight.
	SSP	Basic Output for label printer
	F9	Model 8000 emulation
	Lb1	User definable print string with default values
	Lb2	User definable print string with default values
	Lb3	User definable print string with default values
	Lb4	User definable print string
	ba	WinSPC compatibility format

4.3	br. 2	Baud Rate Port 2
	12	1200 baud
	24	2400 baud
	48	4800 baud
	96	9600 baud
	14.4	14,400 baud
	19.2	19,200 baud
	28.8	28,800 baud
	38.4	38,400 baud

Wired Ethernet - 5 Eeth

5.1	d.o. E	Data Output Mode Ethernet
	t.o.d.	Transmit on demand. Transmit when the PRINT button is pressed.
	A.P.1	Auto Print 1. Transmit once only when scale becomes stable.
	A.P.2	Auto Print 2. Transmit once only when scale becomes stable. Scale must return to, or below, the threshold range (2.5 tH5).
	A.P.4	Auto Print 4. Transmit first stable weight outside of threshold. Transmission happens when weight returns to threshold range (2.5 tH5).
	A.P.5	Auto Print 5. Transmit the last stable weight outside of threshold. Transmission happens when weight returns to threshold range (2.5 tH5).
	t1	Transmits every 1 second.
	t5	Transmits every 5 seconds.
	t60	Transmits every 60 seconds.
	C.P.	Continuous Print. Transmit when display is updated. Approximately every 1/10 th of a second.
	C.P. UDP	Continuous Print. Transmit on selected UDP port when display is updated. Approximately every 1/10 th of a second.
	oFF	Port disabled

Note: only one communication port can have a timed output mode (t1, t5, t60, or CP)

5.2	For. E	Data Output Format Ethernet
	F0	Basic output format
	2d	Basic Dual Print Format. Includes Kilogram weight.
	55P	Basic Output for Label printer
	F9	Model 8000 emulation
	Lb1	User definable print string with default values
	Lb2	User definable print string with default values
	Lb3	User definable print string with default values
	Lb4	User definable print string
	ba	WinSPC compatibility format

5.3	.P.xxxx	Static or DHCP IP Address Assignment
	.P.dhCP	DHCP - address supplied by network server
	.P.StAt	Static - address assigned at indicator

5.4	፣ፆ ለፈገ	Static IP Address Assignment
		Current IP address of the scale. Cannot be changed if the previous parameter is set to DHCP

5.5	ኗህቤኒ	Subnet Mask
		Current subnet setting. Cannot be changed if set for DHCP

5.6	ፍለቴ	IP Gateway
		Current IP Gateway. Cannot be changed if set for DHCP

5.7	ፆፀጥ	TCP Port Number
	xxxxx	Indicates the listening TCP port number of the scale

5.8	ከከላር	Ethernet MAC Address
	xxxxxx.xxxxxx	The unique Ethernet MAC address. Cannot be changed.

5.9	ፋከከላ	4mA point adjustment
	0-255	Use this value to adjust the 4mA output, if that option is installed on your scale. Default is 127 .

5.10	ጊፀከከላ	20mA point adjustment
	0-255	Use this value to adjust the 20mA output, if that option is installed on your scale. Default is 127 .

5.11	UDP IP	UDP IP Address
		Current IP address that the scale will use to send UDP packets.

5.12	UDP Port	UDP Port Number
	xxxxx	Indicates the transmission UDP port number of the scale.

Wireless Ethernet – 6.1

6.1	d.o. WU	Data Output Mode wifi
	t.o.d.	Transmit on demand. Transmit when the PRINT button is pressed.
	A.P.1	Auto Print 1. Transmit once only when scale becomes stable.
	A.P.2	Auto Print 2. Transmit once only when scale becomes stable. Scale must return to, or below, the threshold range (2.5 tH5).
	A.P.4	Auto Print 4. Transmit first stable weight outside of threshold. Transmission happens when weight returns to threshold range (2.5 tH5).
	A.P.5	Auto Print 5. Transmit the last stable weight outside of threshold. Transmission happens when weight returns to threshold range (2.5 tH5).
	t1	Transmits every 1 second.
	t5	Transmits every 5 seconds.
	t60	Transmits every 60 seconds.
	CP	Continuous Print. Transmit when display is updated. Approximately every 1/10 th of a second.
	off	Port disabled

Note: only one communication port can have a timed output mode (t1, t5, t60, or CP)

6.2	For. UU	Data Output Format wifi
	F0	Basic output format
	Zd	Basic Dual Print Format. Includes Kilogram weight.
	SSP	Basic Output for label printer
	F9	Model 8000 emulation
	Lb1	User definable print string with default values
	Lb2	User definable print string with default values
	Lb3	User definable print string with default values
	Lb4	User definable print string
	ba	WinSPC compatibility format

6.3	.P.xxxx	Static or DHCP IP Address Assignment
	.P.dhCP	DHCP - address supplied by network server
	.P.StAt	Static - address assigned at indicator

6.4	.P Adr	Static IP Address Assignment
		Current IP address of the scale. Cannot be changed if the previous parameter is set to DHCP.

6.5	Subnet	Subnet Mask
		Current subnet setting. Cannot be changed if set for DHCP

6.6	Gate	IP Gateway
		Current IP Gateway. Cannot be changed if set for DHCP

6.7	Port	TCP Port Number
	xxxxx	Indicates the listening TCP port number of the scale.

6.8	Idle	Idle Timeout
0 - 65536		<p>Number of seconds during which no data is transmitted or received before the connection is automatically closed. Default is 0 seconds.</p> <p>Setting the timer to 0 prevents disconnecting.</p>

6.9	MAC	Ethernet MAC Address
xxxxxx.xxxxxx		The unique Ethernet MAC address. Cannot be changed.

6.10	WiFi	Wifi Connection Status
		<p>8 - The unit is not connected 88 - The unit is connecting. 888 - The unit is connected</p> <p>There is no entry on this screen. This is a display that reports the wifi connection status.</p>

Bluetooth – 7 bt

7.1	d.o. bt	Data Output Mode Bluetooth
	t.o.d.	Transmit on demand. Transmit when the PRINT button is pressed.
	A.P.1	Auto Print 1. Transmit once only when scale becomes stable.
	A.P.2	Auto Print 2. Transmit once only when scale becomes stable. Scale must return to, or below, the threshold range (2.5 tH5).
	A.P.4	Auto Print 4. Transmit first stable weight outside of threshold. Transmission happens when weight returns to threshold range (2.5 tH5).
	A.P.5	Auto Print 5. Transmit the last stable weight outside of threshold. Transmission happens when weight returns to threshold range (2.5 tH5).
	t1	Transmits every 1 second.
	t5	Transmits every 5 seconds.
	t60	Transmits every 60 seconds.
	C.P.	Continuous Print. Transmit when display is updated. Approximately every 1/10 th of a second.
	oFF	Port disabled

Note: only one communication port can have a timed output mode (t1, t5, t60, or CP)

7.2	For. b	Data Output Format Bluetooth
	F0	Basic output format
	2d	Basic Dual Print Format. Includes Kilogram weight.
	55P	Basic Output for label printers
	F9	Model 8000 emulation
	Lb1	User definable print string with default values
	Lb2	User definable print string with default values
	Lb3	User definable print string with default values
	Lb4	User definable print string
	ba	WinSPC compatibility format

USB – 8 05b

8.1	d.o. 05b	Data Output Mode USB
	t.o.d.	Transmit on demand. Transmit when the PRINT button is pressed.
	A.P.1	Auto Print 1. Transmit once only when scale becomes stable.
	A.P.2	Auto Print 2. Transmit once only when scale becomes stable. Scale must return to, or below, the threshold range (2.5 tH5).
	A.P.4	Auto Print 4. Transmit first stable weight outside of threshold. Transmission happens when weight returns to threshold range (2.5 tH5).
	A.P.5	Auto Print 5. Transmit the last stable weight outside of threshold. Transmission happens when weight returns to threshold range (2.5 tH5).
	t1	Transmits every 1 second.
	t5	Transmits every 5 seconds.
	t60	Transmits every 60 seconds.
	C.P.	Continuous Print. Transmit when display is updated. Approximately every 1/10 th of a second.
	oFF	Port disabled

Note: only one communication port can have a timed output mode (t1, t5, t60, or CP)

8.2	For. 05b	Data Output Format USB
	F0	Basic output format
	2d	Basic Dual Print Format. Includes Kilogram weight.
	55P	Basic Output for label printers
	F9	Model 8000 emulation
	Lb1	User definable print string with default values
	Lb2	User definable print string with default values
	Lb3	User definable print string with default values
	Lb4	User definable print string
	ba	WinSPC compatibility format

Setpoints and Output Operation – 9 OPER

9.4	5.0.	Setpoint Operation	
	no	Do not enter Setpoint Operation	
	YES	Enter menu	
		SP 1-8	Setpoint Mode
		OFF	Setpoint off
		HA	Active High ($wt \geq \text{setpt}_x$)
		LA	Active Low ($wt \leq \text{setpt}_x$)
		HS	Active High ($wt \geq \text{setpt}_x$): only stable weights
		LS	Active Low ($wt \leq \text{setpt}_x$): only stable weights
		HRL	Active High ($wt \geq \text{setpt}_x$): Latching to Threshold Level (2.5 to HS)
		LRL	Output Active Low ($wt \leq \text{setpt}_x$): Latching to Threshold Level
		HSL	Output Active High ($wt \geq \text{setpt}_x$): Latching to Threshold Level (2.5 to HS) and stable weight
		LSL	Output Active Low ($wt \leq \text{setpt}_x$): Latching to Threshold Level (2.5 to HS) and stable weight
		BA_	Band, Active High, only one setpoint activates at a time. ($wt \geq \text{setpt}_x \& wt < \text{setpt}_{x+1}$) (not available on SP8)
		BS_	Band, Active High, only one setpoint activates at a time. ($wt \geq \text{setpt}_x \& wt < \text{setpt}_{x+1}$): only stable weights. (not available on SP8)
		BSL	Band, Active High, only one setpoint activates at a time. ($wt \geq \text{setpt}_x \& wt < \text{setpt}_{x+1}$): Latching to Threshold Level (2.5 to HS) and stable weight. (not available on SP8)
		Fill	Tank fill operation. SP2 only. See tank fill section for details.

9.5	5.0.	Setpoint Weight Operation
		Weight that is used to evaluate the Setpoint logic
	dSP	Currently displayed weight
	net	Net weight
	grs	Gross weight

9.6	PrE	Preact Adjustment % Configuration	
	no	Do not enter menu	
	YES	Enter menu	
		P 1-8	Preact Configuration
		xx	Enter preact adjustment % Range: 1 to 90 %

9.7	out	Output Configuration	
	no	Do not enter Output selection menu	
	YES	Enter menu	
		o 1-8	Output Configuration
		o 1 OFF	Output is deactivated
		o 1 SP1	Setpoint 1 used for output logic
		o 1 SP2	Setpoint 2 used for output logic
		o 1 SP3	Setpoint 3 used for output logic
		o 1 SP4	Setpoint 4 used for output logic
		o 1 SP5	Setpoint 5 used for output logic
		o 1 SP6	Setpoint 6 used for output logic
		o 1 SP7	Setpoint 7 used for output logic
		o 1 SP8	Setpoint 8 used for output logic
		o 1 TH5	Weight below threshold level (2.5 tH5) used for output logic
		o 1 in1	Remote Switch Input Logic 1 used for output logic
		o 1 in2	Remote Switch Input Logic 2 used for output logic
		bat	State controlled by batch program commands

Exit – 99 don

10.1	donE	Exit and save changes
	n	Do not exit
	y	Save changes and exit

Data Communications

To confirm data has been transmitted, the display will show a "r" in the leftmost digit.

Transmit on Demand (t0d)

In this mode, scale data is transmitted whenever PRINT is pressed, a remote switch configured for a PRINT command is pressed, or a print request is received at the serial port. The scale must be stable and the scale value must be valid before the data is transmitted.

Timer 1 (t1)

Transmits every 1 second.

Timer 5 (t5)

Transmits every 5 seconds.

Timer 60 (t60)

Transmits every 60 seconds.

Continuous Data Transmission (tP)

Data is transmitted each time the scale display updates. Readings which occur when the scale is in motion are indicated out by the abbreviation "MOT." after the weight data.

Auto Print 1 (AP1)

Auto Print 1 transmits the first stable scale reading each time the scale leaves motion.

Auto Print 2 (AP2)

Auto Print 2 transmits the first stable scale reading following the scale leaving motion and above the adjustable threshold level. To adjust the Threshold level as a % of capacity, see the Threshold Level (2.5 tH5) parameter. In Auto Print 2, no further readings will be sent until the scale returns to weight reading that is below the adjustable threshold level.

Auto Print 4 (AP4)

Auto Print 4 transmits the first stable scale reading following the scale leaving motion that is above the adjustable threshold level. Transmission does not occur until the scale returns below the threshold value. To adjust the threshold level as a % of capacity, see the Threshold Level (2.5 tH5) parameter.

Auto Print 5 (AP5)

Auto Print 5 transmits the last stable scale reading following the scale leaving motion that is above the adjustable threshold level. Transmission does not occur until the scale returns below the threshold value. To adjust the threshold level as a % of capacity, see the Threshold Level (2.5 tH5) parameter.

Data String Formatting

Many predefined data formats are available. This allows for flexibility when communicating with a database, printer, remote display or other devices.

The LB1-4 custom data strings provide the opportunity to define a custom print string up to 64 characters in length.

Note: Lb:oz unit is not supported in data strings.

	Print String	Description
F0	<p>Standard Output Format</p> <p><STX><p><xxxx.xx><SP><uu><SP><MOT><CR><LF></p> <p>Sample Print String ±--10.05-lb</p> <p>Note: "-" represents a space</p>	<p><STX> Start of Text (02h)</p> <p><p> Weight Polarity Negative weight "-", positive weight space (20h)</p> <p><xxxx.xx> Weight Data fixed field of 6 digits plus decimal. In overload or underload "-----". Leading zeros are spaces (20h).</p> <p><uu> Displayed Units "lb", "kg", "oz", "g"</p> <p><MOT> (Available only in Continuous print mode) Motion Status Appends "MOT" to the print string when printing while in motion</p> <p><SP> Line Space (20h)</p> <p><CR> Carriage Return (0dh)</p> <p><LF> Line Feed (0Ah)</p>
2d	<p>Dual Unit lb and kg Print Output Format</p> <p><STX><p><xxxx.xx><SP><uu><SP><MOT><CR><LF></p> <p><(><p><xxxx.xx><SP><kg><SP>< ><MOT><CR><LF></p> <p>Sample Print String ±--10.05-lb ±---4.56-kg</p> <p>Note: "-" represents a space</p>	<p><STX> Start of Text (02h)</p> <p><p> Weight Polarity Negative weight "-", positive weight space (20h)</p> <p><xxxx.xx> Weight Data fixed field of 6 digits plus decimal. In overload or underload "-----". Leading zeros are spaces (20h)</p> <p><uu> Displayed Units "lb", "kg", "oz", "g"</p> <p><MOT> (Available only in Continuous print mode) Motion Status Appends "MOT" to the print string when printing while in motion</p> <p><SP> Line Space (20h)</p> <p><CR> Carriage Return (0dh)</p> <p><LF> Line Feed (0Ah)</p>

	Print String	Description
55P	<p>Label Printer Output Format</p> <pre><FR"L1"><LF><?><LF><p><xxxx.xx><LF> ><uu><LF><"GS"><LF><MOT><LF><p> <xxxx.xx><LF><kg><LF><P1,1><LF></pre> <p>Sample Print String</p> <pre>FR"L1" ? ±--10.05 lb GS MOT ±---4.56 kg P1,1</pre> <p>Note: "-" represents a space</p>	<p><p> Weight Polarity Negative weight "-", positive weight space (20h)</p> <p><xxxx.xx> Weight Data fixed field of 6 digits plus decimal. In overload or underload "-----". Leading zeros are spaces (20h)</p> <p><uu> Displayed Units "lb", "kg", "oz", "g"</p> <p><MOT> (Available only in Continuous print mode) Motion Status Appends "MOT" to the print string when printing while in motion</p> <p><SP> Line Space (20h)</p> <p><CR> Carriage Return (0dh)</p> <p><LF> Line Feed (0Ah)</p>
F9	<p>Prints current weight, units, and "grs".</p> <pre><STX><p><xxxx.xx><SP><uu><SP><grs> ><MOT><CR><LF></pre> <p>Sample Print String</p> <pre>±--10.05-lb-grs</pre> <p>Note: "-" represents a space</p>	<p><STX> Start of Text (02h)</p> <p><p> Weight Polarity Negative weight "-", positive weight space (20h)</p> <p><xxxx.xx> Weight Data fixed field of 6 digits plus decimal. In overload or underload "-----". Leading zeros are spaces (20h)</p> <p><uu> Displayed Units "lb", "kg", "oz", "g"</p> <p><MOT> (Available only in Continuous print mode) Motion Status Appends "MOT" to the print string when printing while in motion</p> <p><SP> Line Space (20h)</p> <p><CR> Carriage Return (0dh)</p> <p><LF> Line Feed (0Ah)</p>

	Print String	Description
1b1	<p>Custom Data String 1 (x\w \u \m\r\l)</p> <p><STX><p><xxxx.xx><SP><uu><SP><MOT><CR><LF></p> <p>Sample Print String ±--10.05-lb</p> <p>Note: "-" represents a space</p>	<p><STX> Start of Text (02h)</p> <p><p> Weight Polarity Negative weight "-", positive weight space (20h)</p> <p><xxxx.xx> Weight Data fixed field of 6 digits plus decimal. In overload or underload "-----". Leading zeros are spaces (20h)</p> <p><uu> Displayed Units "lb", "kg", "oz", "g"</p> <p><MOT> (Available only in Continuous print mode) Motion Status Appends "MOT" to the print string when printing while in motion</p> <p><SP> Line Space (20h)</p> <p><CR> Carriage Return (0dh)</p> <p><LF> Line Feed (0Ah)</p>
1b2	<p>Custom Data String 2 (x\w \u \m\r\l)</p> <p><STX><p><xxxx.xx><SP><uu><SP><MOT><CR><LF></p> <p>Sample Print String ±--10.05-lb-ACCEPT</p> <p>Note: "-" represents a space</p>	<p><STX> Start of Text (02h)</p> <p><p> Weight Polarity Negative weight "-", positive weight space (20h)</p> <p><xxxx.xx> Weight Data fixed field of 6 digits plus decimal. In overload or underload "-----". Leading zeros are spaces (20h)</p> <p><uu> Displayed Units "lb", "kg", "oz", "g"</p> <p><MOT> (Available only in Continuous print mode) Motion Status Appends "MOT" to the print string when printing while in motion</p> <p><SP> Line Space (20h)</p> <p><CR> Carriage Return (0dh)</p> <p><LF> Line Feed (0Ah)</p>

	Print String	Description
1b3	<p>Custom Data String 3(\xID:\i \w \u \m\r\l)</p> <p><STX><"ID:"><SP><p><xxxx.xx><SP><uu><SP><MOT><CR><LF></p> <p>Sample Print String ID:00-±--10.05-lb</p> <p>Note: "-" represents a space</p>	<p><p> Weight Polarity Negative weight "-", positive weight space (20h) <xxxx.xx> Weight Data fixed field of 6 digits plus decimal. In overload or underload "-----". Leading zeros are spaces (20h) <SP> Line Space (20h) <uu> Displayed Units "lb", "kg", "oz", "g" <MOT> (Available only in Continuous print mode , non-LFT) Motion Status Appends "MOT" to the print string when printing while in motion. <CR> Carriage Return (0dh) <LF> Line Feed (0Ah)</p>
1b4	<p>Custom Data String 4(\a \u \r\l\c\r\IP1\r\l)</p> <p><accumulator><SP><uu><SP><CR><LF><counter><CR><LF>"P1" <CR><LF></p> <p>Sample Print String +--10.05-lb- ----36 P1</p> <p>Note: "-" represents a space</p>	<p><+/-xxxx.xx > Weight Data fixed field of 6 digits plus decimal. In overload or underload "-----". Leading zeros are spaces (20h) space (20h) <uu> Displayed Units "lb", "kg", "oz", "g" space (20h) <CR> Carriage Return (0dh) <LF> Line Feed (0Ah) <xxxxxx>counter, Leading zeros are spaces (20h) <CR> Carriage Return (0dh) <LF> Line Feed (0Ah) <CR> Carriage Return (0dh) <LF> Line Feed (0Ah)</p>
1b0	<p>Prints weight with polarity and units</p> <p><p><xxxx.xx><SP><uu><SP><CR><LF></p> <p>Sample Print String ±--10.05-lb</p> <p>Note: "-" represents a space</p>	<p><p> Weight Polarity Negative weight "-", positive weight space (20h) <xxxx.xx> Weight Data fixed field of 6 digits plus decimal. In overload or underload "-----". Leading zeros are spaces (20h). <SP> Line Space (20h) <uu> Displayed Units "lb", "kg", "oz", "g" <CR> Carriage Return (0dh) <LF> Line Feed (0Ah)</p>

Custom Data String Configuration

Command	Length	Description
\A	8	Accumulated weight: 6 digits with leading zeros, polarity, and a decimal point. Positive polarity is represented as "0"
\ax	6-8	Accumulated weight, with weight format "x" (x = 1-5)
\B	0	Clears the Accumulator and Counter
\BS	4	Battery Status. Low: "batt" OK: "BATT"
\b	2	Current batch number
\C	7	Accumulation counter, 7 digits, leading zeros
\c	7	Accumulation counter, 7 digits, leading spaces
\D10	Up to 40	Product description 1, up to 40 characters. Field length = number of characters entered
\D1F	40	Product description 1, all 40 characters. Trailing spaces added where no entry exists
\D20	Up to 40	Product description 2, up to 40 characters. Field length = number of characters entered
\D2F	40	Product description 2, all 40 characters. Trailing spaces added where no entry exists
\d	1-3	Motion aperture ("0.5", "1", "2", "3", "5", "10")
\e	4	Threshold: 2 digits, decimal, and "%"
\hxx	1	HEX byte. "xx" can be 00 through FF
\I0	Up to 20	Current Product ID, up to characters. Field length = number of characters entered
\IF	20	Current Product ID, all 20 characters. Trailing spaces added where no entry exists
\J	2	Real time clock date. "01" – "31"
\Jpxxx	2	Real time clock date + xxx days. "01" – "31"
\JJ	3	Julian date, 3 characters
\l	1	Linefeed. ASCII 0x0A
\M	2	Real time clock month. "01" – "12"
\Mpxxx	2	Real time clock month + xxx days. "01" – "12"
\m	0 or 3	Motion status. "MOT" if in motion, no output if stable
\Nx	4	Setpoint "x" operation (x = 1-8) Setpoint number, colon, 2 digits
\nx	6-8	Current NET weight, with weight format "x" (x = 1-5)
\Ox	4	Output "x" operation (x = 1-8). Setpoint number, colon, 2 digits
\Px	9	Preact "x" weight (x = 1-8). Preact number, colon, 6 digits with decimal
\P0x	Up to 40	Product field "x" (x = 1-8), up to 40 characters characters. Field length = number of characters entered
\PFx	40	Product field "x" (x = 1-8), all 40 characters. Trailing spaces added where no entry exists
\P9	5	Product field 9 (counter). 5 digits with leading zeros
\Qx	5	Preact percentage "x" (x = 1-8). Preact number, colon, space, with 2 digits for percentage.
\qx	6-8	Current GROSS weight, with weight format "x" (x = 1-5)

\R	0	Clears TARE and places scale in the GROSS MODE
\r	1	Carriage return. ASCII 0x0D
\Sx	10	Setpoint weight "x" (x = 1-8). Setpoint number, colon, space, and 6 digits with decimal
\TC	7	12-hour time: HH:MM "AM" or "PM"
\Tc	10	12-hour time with seconds: HH:MM:SS "AM" or "PM"
\TM	5	24-hour time: HH:MM
\Tm	8	24-hour time with seconds: HH:MM:SS
\TP	2	"AM" or "PM"
\ts	3	Current TARE status, "grs" or "net"
\tx	6-8	Current TARE weight, with weight format "x" (x = 1-5)
\u	1-2	Current unit. "lb", "kg", "g", "oz". Two characters except for grams which is one
\W	2	Current weighing mode. "GS" for GROSS and "NT" for NET
\wx	6-8	Current weight, with weight format "x" (x = 1-5)
\x	1	Start of text character. ASCII 0x02
\Y	2	Real time clock year. "00" – "99"
\Ypxxx	2	Real time clock year + xxx days. "00" – "99"
\Y1	1	Least significant digit of year
\y	1	Current weight polarity. "-" or a space
\y0	1	Current weight polarity. "-" or "0"
\Z	0	ZERO command

"x" Weight Formats	
1	8 total characters. Polarity, 6 digits + decimal with leading spaces.
2	8 total characters. Polarity, 6 digits + decimal with leading zeros.
3	7 total characters. No polarity, 6 digits + decimal with leading spaces.
4	7 total characters. No polarity, 6 digits + decimal with leading zeros.
5	6 total characters. No polarity, 6 digits no decimal with leading zeros

Plain text can be inserted into the data string. No control character or slash is necessary for plain text entry.

To download a custom data string, the string must be prefaced by a command to tell the indicator to expect a custom print string.

ELx<string>↵ Enter (Download) custom data string
RLx↵ Read (Upload) custom data string

x is the label buffer number (1 to 4)

↵ is carriage return or enter key in terminal program

The data string can have up to 62 control characters. For example, the following string is 8 characters in length “\w\u\r\|”. The custom string is terminated and download by pressing the enter. To program this string for Lb1 location in the scale’s memory, send the following string:EL1\u\r\|↵

Once programmed, set the Output Format **For** parameter to **Lb1** to activate the print string.

Remote Commands

All serial commands require a carriage return (0x0D) as a terminator. Commands can be entered on any communication option or serial port.

W, w	Weight is transmitted out all enabled ports in the format selected for each port.
Wx, wx	Custom data string Lb1-4 can be requested to transmit out all ports. x = 1, 2, 3 or 4.
P, p	Weight data is sent out serial port 2 only
Px, px	Customer data string Lb1-4 can be requested to transmit out serial port 2 only. x = 1, 2, 3, or 4.
U, u	Causes the scale to switch to the next unit of measure. Same as if the UNITS button is pressed.
Ux, ux	Causes the scale to switch to the unit of measure specified by 'x'. x = 1, 2, 3, or 4 where 1=lb, 2=kg, 3=g, 4=oz.
Z, z	Issues a ZERO command to the scale. Note: Scale will not zero if in motion or if an error is displayed.
T, t	Issues a TARE command to the scale. Note: Scale will not TARE if in motion or if an error is displayed.
G, g	Places the scale into gross weight mode.
N, n	Places the scale into net weight mode. Note: The indicator will not be able to enter the net mode if a tare is not present.
MD	The scale will transmit its model number
RV	The scale will transmit its revision number
ELx<data>	Load the user data string, specified by 'x' (1-4), with the data in <data>. <data> can be up to 64 bytes. The indicator responds with an '*' if the command is successful or '?' if unsuccessful.
RLx	Transmit the User data string stored in the location referenced by 'x'.
SW1	The indicator transmits the current wifi SSID.
SW2	The indicator transmits the current wifi password. Only works if scale is in CAL menu.

SW3	Force the wifi option board to reboot and attempt to reconnect.
SW4<data>	Send an SSID to the indicator. The scale will respond with a '*' if the operation was successful and a '?' if it was unsuccessful.
SW5<data>	Send a wifi password to the scale. The scale will respond with a '*' if the operation was successful and a '?' if it was unsuccessful.
SW6	The scale will transmit its current wifi IP address.
SW7	The scale will transmit the current wifi IP port it is using.
SW8<data>	Enter transmit strength (strength 0-12, input in hexadecimal 0-C)
ipconfig	Returns IP address, subnet, gateway, port, SSID, and wifi password
SWB	Displays the received signal strength (RSSI) of a connected wifi board. Note: Refer to the wifi troubleshooting section for more information.
SWC	Removes the wifi board from RSSI mode and return it to normal communications
^Rxx.yy.	Request parameter setting in the format of calibration/setup menu group xx, sub-menu yy. For example: ^R02.05<0x0D> will cause the scale to transmit its threshold value on the port that this command was received on.
^Exx.yy.	This command will enter data to the scale in calibration/setup menu group xx, menu yy. Scale must be in CAL menu.
^RP	Reports the current product
^EP<data>	Enter product
^RRx	Report Preact 'x' ('A' for all)
^ERx<data>	Enter Preact 'x' ('A' for all)
^RSx	Report Setpoint 'x' ('A' for all)
^ESx<data>	Enter Setpoint 'x' ('A' for all)
^RBx	Report Batch 'x' ('A' for all)
^EBx<data>	Enter Batch 'x' ('A' for all)
^RFx	Report remote button function 'x' (x = 1 or 2)

^EFx<data>	Enter remote button function 'x' (x = 1 or 2)
^PX	Delete all products
^PD	Delete one product
x1	RS232 port 1 is echoed to RS232 port 2
x2	RS232 port 2 input is echoed to RS2332 port 2
x3	Ethernet is echoed to port 2
x4	Wireless ethernet is echoed to port 2
x5	Scale displays raw counts
x6	Wired ethernet is echoed to USB
x7	Wireless ethernet is echoed to USB
xc	Clears all 'x' commands
xhbn	Enables ethernet "heartbeat" text. Every 30 seconds of ethernet inactivity, hex value 0xCE is output.
xhbf	Disables ethernet "heartbeat" text.

For a complete protocol, please request this document from Doran Technical Support at tech@doranscales.com.

Internal Relay Option

The Internal Relay Option allows up to four relays to be mounted inside the indicator. Three types of relays are available for use with the Internal Relay Option – 6Vdc Electromechanical and Solid State (AC or DC). Specify style of relay at time of order.

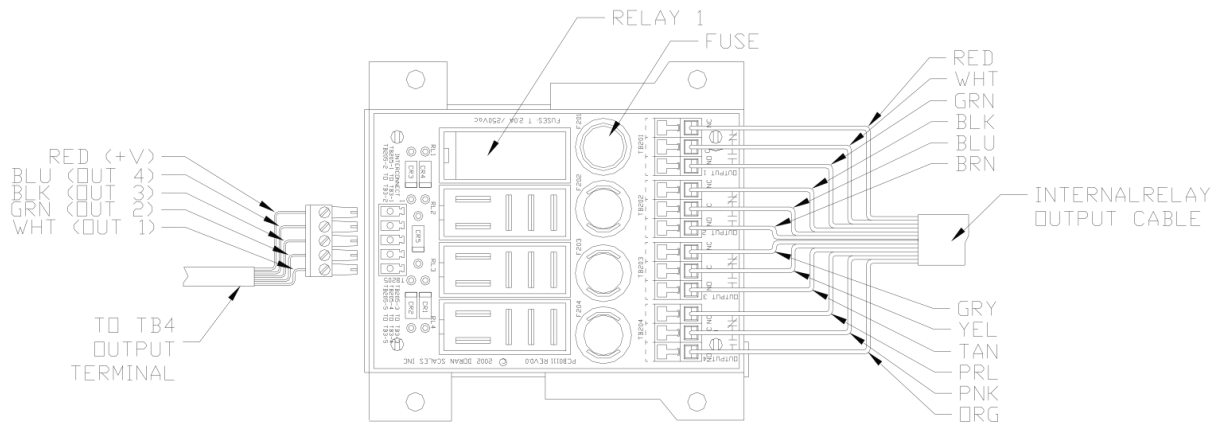

Internal Relay Board

Internal Relay Setup:

A twelve conductor cable provides the relay output connections that exits the meter through a watertight. Leave this cable in place when configuring the outputs and refer to the output cable color code table. The Scale does not provide the AC or DC power to run external devices.

Each relay has a three-position output that provides a Common, Normally Open and Normally Closed terminal. The Normally Closed terminal is only available for use with a mechanical relay. Solid State relays can operate as Normally Closed through software configuration only. The following table shows the color codes and terminal connections for the included cable.

Relay Specifications:

6VDC Mechanical Relay, 10A 250VAC / 30VDC

AC Solid State Relay, 2A 100-240VAC

DC Solid State Relay, 2A 5-48VDC

Internal Relay Output Cable Color Code		
Channel	Terminal	Conductor Color
Relay 1 (OUTPUT 1)	TB201 – NC	Red
	TB201 – COM	White
	TB201 – NO	Green
Relay 2 (OUTPUT 2)	TB202 – NC	Black
	TB202 – COM	Blue
	TB202 – NO	Brown
Relay 3 (OUTPUT 3)	TB203 – NC	Grey
	TB203 – COM	Yellow
	TB203 – NO	Tan
Relay 4 (OUTPUT 4)	TB204 – NC	Purple (Pearl)
	TB204 – COM	Pink
	TB204 – NO	Orange

Step-up Relay Circuit

If the current load to be switched is greater than the maximum current limit of the internal relay, i.e. 10 Amps for mechanical relay or 2 Amps for Solid State Relay, a step-up relay circuit is required in order to switch to the higher current loads.

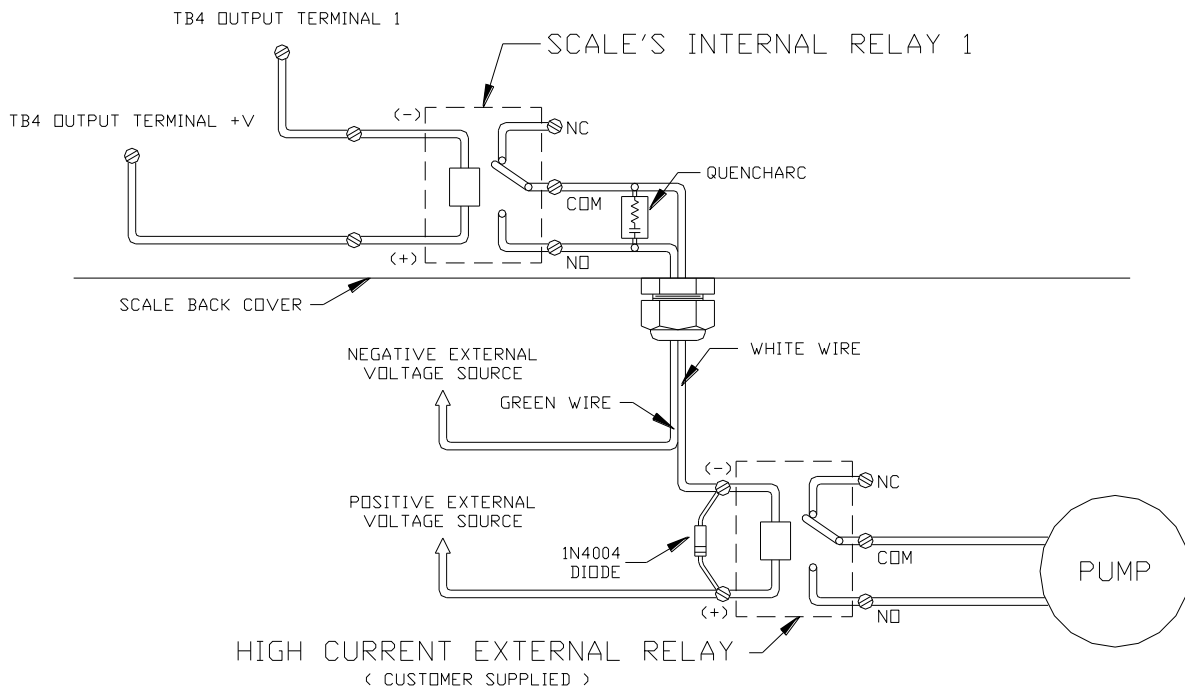

External Relay Box Option

The External Relay Box Option consists of up to eight DIN rail mounted relay modules. The Relay Box is a NEMA4X polystyrene enclosure with a clear cover and knock-out plugs with sizes of 7/8", 1-1/8", 1-1/2". Three types of relays are available for use with the External Relay Box Option – Electromechanical and Solid State (AC or DC). Shown below with optional a +6V Power Supply.

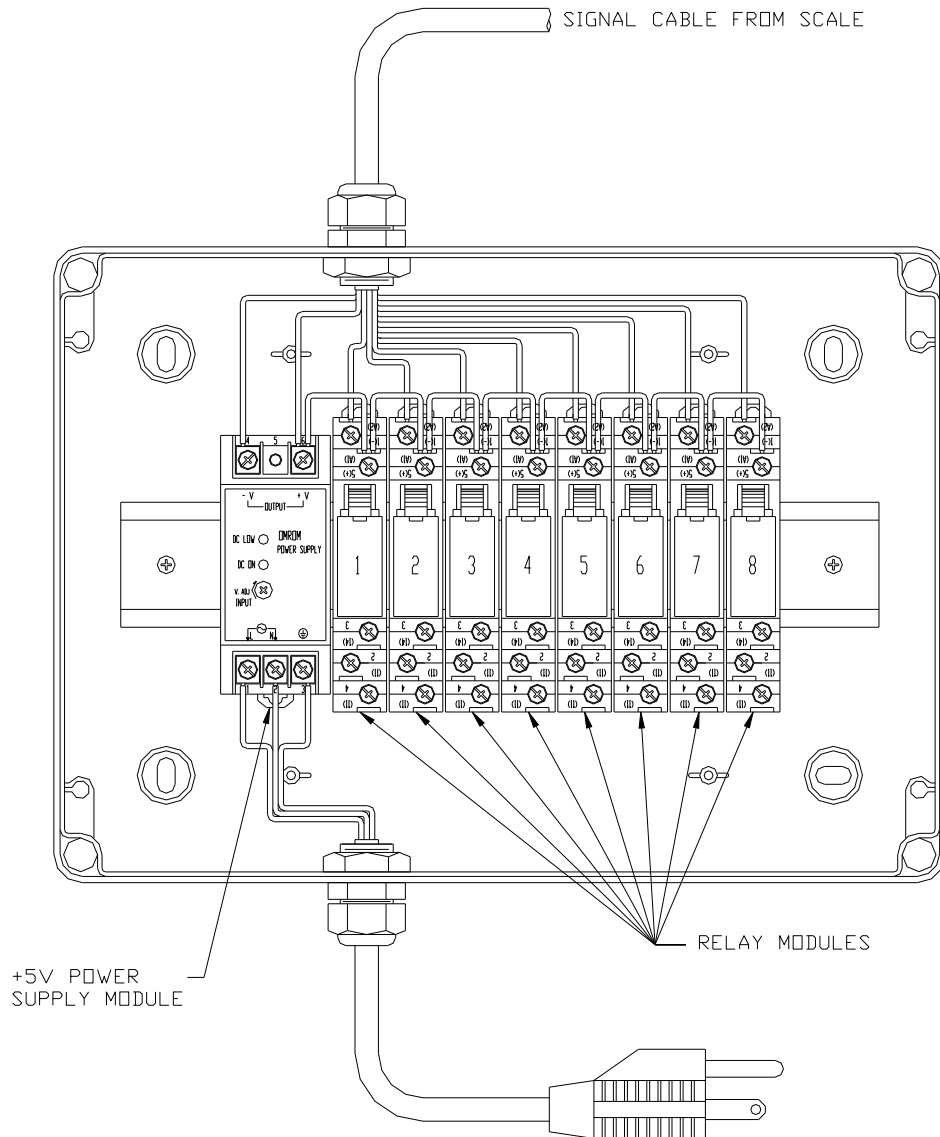

External Relay Setup:

The Relay module is offered with three types of relays, mechanical and solid state (AC or DC). The mechanical relay's output consists of terminal 4 - common (COM), terminal 3 - normally open (NO), and terminal 2 - normally closed (NC).

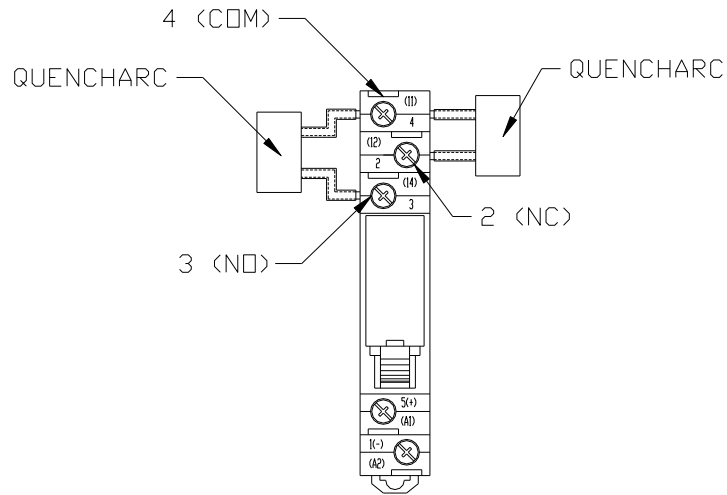

Scale Signal Cable Color Code		
Module	Terminal	Conductor Color
Relay 1	1(-) A2	Brown
Relay 2	1(-) A2	Red
Relay 3	1(-) A2	Orange
Relay 4	1(-) A2	Yellow
Relay 5	1(-) A2	Green
Relay 6	1(-) A2	Blue
Relay 7	1(-) A2	Purple
Relay 8	1(-) A2	Grey
Power Supply	Output +V	White
Power Supply	Output -V	Black

4-20mA Analog Output Option

Introduction

The 4-20mA Analog Output Option is used to provide an analog output that is proportional to the weight on the scale platform. The option board provides an active power loop for the communications. The 4-20mA analog output option can be used to send weight data to a process indicator, a simple on/off controller or to a programmable logic controller.

Setup

The 4-20mA option is automatically calibrated for an output range of 4mA to 20mA, (i.e. 4mA equals zero weight and 20mA equals the scale's capacity). Attach the output cable from the 4-20mA option board to an appropriate controller or indicator. The white lead is connected to the + input of TB2 and the black lead is connected to the – input of TB2.

Calibrate your process indicator or controller according to the manufacturer's instructions. Remember that the option will output 4mA when the scale reads "zero" and 20mA when the scale reads full capacity.

Operation

There is no effect on scale operation, when the 4-20mA Analog Output option is installed, except for battery units which will see a reduction in battery life of approximately 50%.

Wired Ethernet Option

The Ethernet module is installed inside the indicator enclosure. The NEMA4X sealed RJ-45 Ethernet connector is bulkhead mounted to the rear panel of the indicator.

The Wired Ethernet Option auto senses 10/100Base-T networks. The Wired Ethernet Option is fully compliant with the 10/100Base-T Ethernet network standard, transferring data up to 100Mbps. Once the scale is connected you can collect data, remotely configure, or monitor the scale from any computer on the network.

Specifications

Hardware: Bulkhead mount NEMA4X sealed RJ-45 connector

Network Interface:

10/100Base-T Ethernet protocol, Data rates up to 100Mbps

Universal IP address assignment

Static IP

DHCP

Operating Temp. 14° F to 104° F

Options:

Washdown Safe RJ-45 Ethernet Connector Field Install Kit

Wireless 802.11b/g Ethernet Option

The Wireless Ethernet Option is fully compliant with the 802.11b/g wireless network standard. Wireless communications are protected by up to a 128-bit security encryption.

Specifications

Hardware: Bulkhead mount 2.4 GHz Dipole Antenna

Network Interface:

802.11b/g Ethernet Protocol

Universal IP address assignment

Static IP

DHCP

2.4 GHz Frequency

12dBm Transmitting Power

Receiving Sensitivity

-83dBm(Typ.)

Operating Temp. 14° F to 104° F

Wireless Security: WEP-128, WPA-PSK (TKIP), WPA2-PSK (AES)

Regulatory Approval: FCC ID: T9J-RN171

This equipment has been tested and found to comply with the limits for a Class B digital device, pursuant to part 15 of the FCC Rules. These limits are designed to provide reasonable protection against harmful interference in a residential installation. This equipment generates, uses and can radiate radio frequency energy, and if not installed and used in accordance with the instructions, may cause harmful interference to radio communications. However, there is no guarantee that interference will not occur in a particular installation. If this equipment does cause harmful interference to radio or television reception, which can be determined by turning the equipment off and on, the user is encouraged to try to correct the interference by one or more of the following measures:

- Reorient or relocate the receiving antenna
- Increase the separation between the equipment and receiver
- Connect the equipment into an outlet on a circuit different from that to which the receiver is connected
- Consult the dealer or an experienced radio technician for help

Troubleshooting Wifi

If WIFI is not functioning, try the following procedures:

Confirm IP Configuration

Enter the scale's calibration mode (as detailed on page 24) and navigate to parameter group 6 for WIFI. Press ZERO to enter the group, then use UNITS and PRINT to navigate within this group. Ensure that:

- `d.d.uu` is not set to `off`
- The ip address is properly set
- The subnet mask is properly set
- The ip gateway is properly set
- The port is properly set

Confirm WIFI connection

Enter the scale's calibration mode (see Scale Parameter Setup) and navigate to parameter group 6 for WIFI. Press ZERO to enter the group, then use UNITS and PRINT to navigate within this group. Navigate to the final parameter "`75`". If it reads:

- 8 – The unit is not connected
- 88 – The unit is connecting
- 888 – The unit is connected

If the scale is having trouble connecting, consider repositioning the scale and its antenna to strengthen the connection.

Once the scale is connected to Doran's terminal program Dimension, the exact signal strength can be found using the SWB remote command. See the below table for a guide to this signal strength:

Quality:	Wifi decibel value:
Excellent	Greater than -60dB
Good	-60dB – -75dB
Poor	Less than -75dB

Bluetooth Option

Doran Scale's Bluetooth option is a Class 3, Bluetooth 4.0, configured for SPP. The Bluetooth option does not require any external antenna for communication. Once paired, the Bluetooth module will function as a wireless RS232 serial cable. Each Bluetooth module has an individual 12-digit address i.e. "34:81:F4:13:C8:CE".

Computer Setup

To connect the scale's Bluetooth module with your computer; the computer will need to have a Bluetooth device installed. Some computers may or may not have a Bluetooth option. If there is no existing Bluetooth device, a Bluetooth USB dongle can be used. Follow the instructions included with the Bluetooth dongle software to setup the computer.

Bluetooth USB Dongle

Since Bluetooth software drivers and hardware varies among manufacturers, it is recommended to use the USB Bluetooth dongle available from Doran. Support is not available if the customer is not using the Doran supplied USB dongle.

Scale Setup

Please refer to the "1 6" parameter group for configuring the scale to transmit data over Bluetooth.

Pairing Devices (Scale)

The scale's Bluetooth module must be paired with your computer to communicate properly. Turn on the scale with the Bluetooth option installed. Be sure to have the scale near the computer to prevent any interference with communication while configuring the Bluetooth module. Wait 30 seconds after the scale is powered up to allow the scale's Bluetooth module to become available.

Bluetooth Specifications

Feature	Implementation
Bluetooth Transmission:	Class 3
Fully Bluetooth:	Bluetooth SIG QDID: B021961
Range:	Up to 10 meters
Frequency:	2.402 – 2.480 GHz
Transmit Power:	+2dBm (typ.)
Receive Sensitivity:	-90dBm (Classic); -92dBm (LE)
Profile:	SPP Serial Port Profile

Bluetooth Pairing Instructions

The following example connects the scale to a Toshiba Bluetooth Stack running on a Windows PC.

Click New Connection

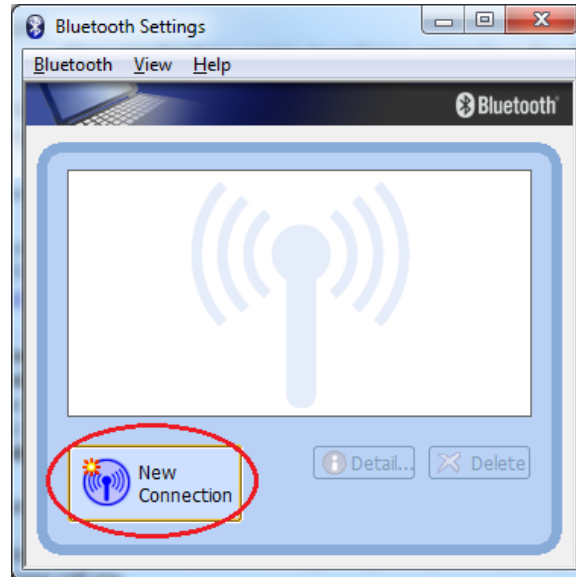

Click Next

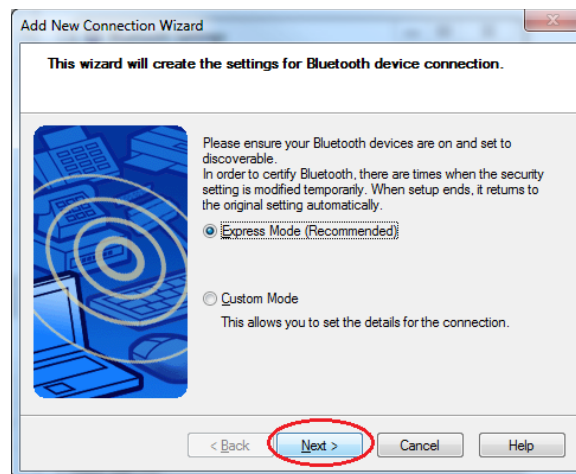

The driver will search for the scale.

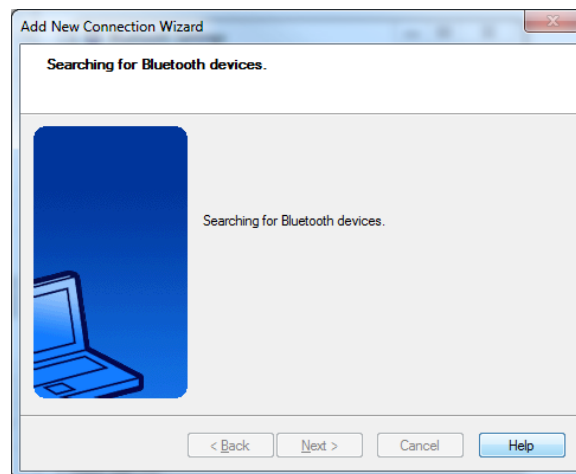

Select Dual-SPP and click Next

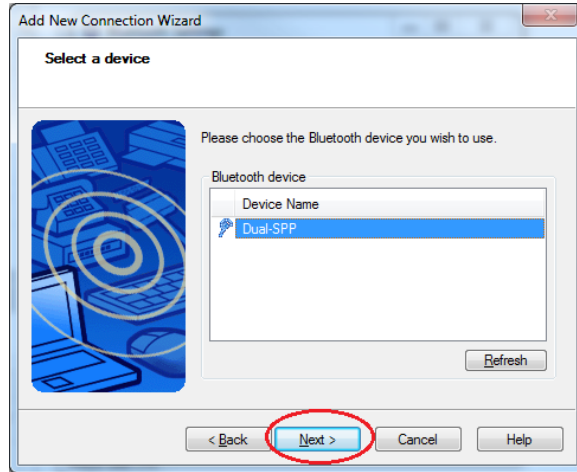

Click Next once to pair

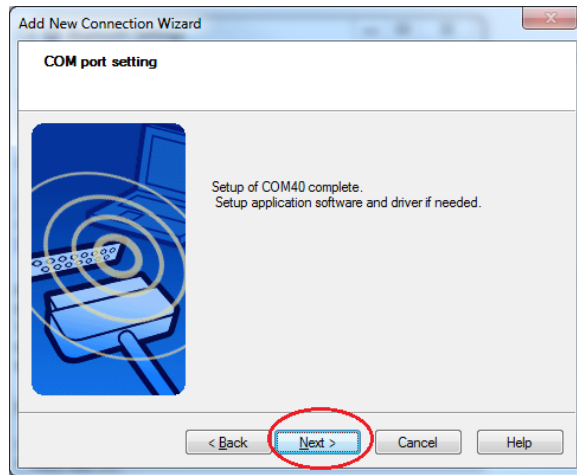

Right-click Dual-SPP and choose Connect

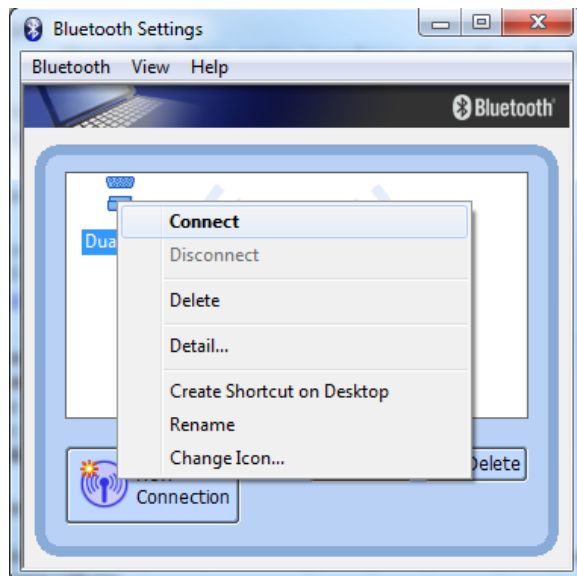

Click Yes to connect

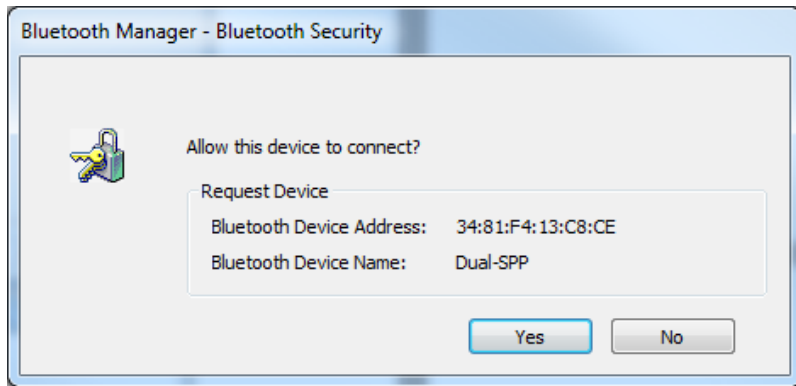

Right-click Dual-SPP and choose Detail...

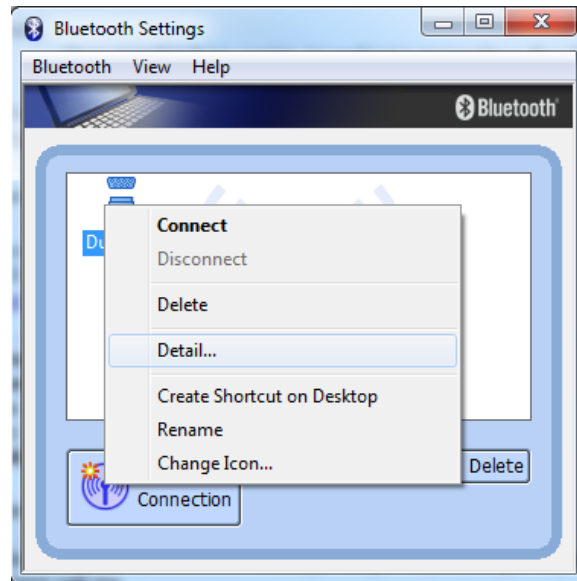

The COM number will be displayed

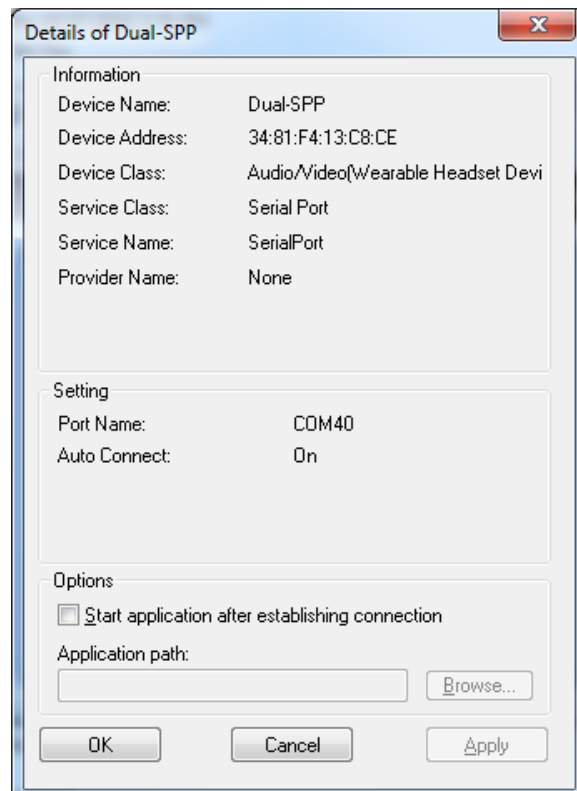

Right-click Dual-SPP and choose Connect

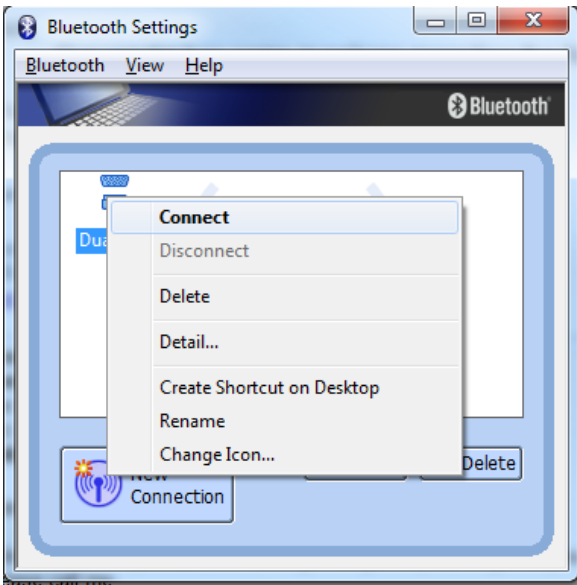

Troubleshooting

If any problem persists, contact Doran Tech Support at tech@doranscales.com

Problem	What to Do or Check
Weight reading will not repeat or does not return to zero when weight is removed	Examine the weighing platform for any interferences. Be sure that nothing is inside the platform, under the load cell or the weigh bridge structure
Scale overloads before reaching full capacity	Make sure all four corner overload stops are properly set, if present. Take the platter off the scale, invert it and place it on the platform. With 1/2 of the scale's capacity in test weights concentrated over a corner of the platform, there should be approximately 1/32" of clearance between the stop and the bottom of the spider. Check all four corners then recalibrate the scale.
Scale will not indicate full capacity or go into overload	Make sure that there is nothing caught in the scale under or around the load cell or spider, which would interfere with their movement. If not, check the overload stops using the above procedure.
Scale will not zero when the ZERO button is pressed	Make sure that the scale is stable ( annunciator is off) when ZERO is pressed. If excessive motion is a problem, then it may be necessary to activate the Zero on Demand or change the Display Filter parameter.
Weight readings don't seem to be correct	Check the scale's accuracy with a test weight. Recalibrate if necessary.
Scale drifts off of zero	Check for air currents and/or vibration around the scale. If that is the cause, it may be necessary to set the AZT parameter to a wider setting to compensate
Scale reading is bouncing	Check for air currents and/or vibration around the scale. If that is the cause, it may be necessary to change the Display Filter parameter.

Scale Messages

Message	Meaning
ZERO Pb	ZERO pressed and held past needed period
PASSon	Password enabled
Abort	Invalid value entry or screen timeout
CLtAc	0 Tare value has been entered / Tare has been cleared
Er nno	Calibration error: motion detected
Over Ld	The scale reading an overload condition
Under Ld	The scale is reading an underload condition
Ldn9 0	“Loading Zero” - the scale is filling the average buffer value and does not yet have a valid weight reading
done	Calibration completed
SAvEd	Exiting CAL mode or other data entry modes
tArE	Prompt for Tare display and entry
dAtE	Display and prompt to enter RTC date
tImE	Display and prompt to enter RTC time
CLr Ac	“Clear Accumulator” - Can be specifically asked for, or happens when units are changed
Ent Cd	Prompt for code entry to get into CAL mode
Error	Improper value entered or improper action requested
Prd Id	Prompt for Product ID selection
nEwU	New Product ID saved from the front panel
CLr Id	Product ID deleted from the front panel
PF 1 – PF 2	Prompt for entry of Product Fields 1 – 9
SEtPt	Setpoint display and entry
PrERct	Preact display and entry

Default to Factory Settings

To return the setup parameters to factory default, follow these steps.

1. Enter Calibration

Front Panel Access

1. Press and hold ZERO and UNITS simultaneously until the audit counters are displayed.
2. Σ Σ is displayed
3. Press ZERO 5 times, so that Σ is displayed,
4. Press UNITS

Internal Calibration Button

The calibration push button is located near the center of the board and labeled CAL. Press this button to enter calibration and setup.

2. Press ZERO to enter the Σ Σ parameter group
3. Press UNITS to scroll to menu item Σ Σ .
4. Press ZERO to change selection to Σ Σ .
5. Press UNITS to advance. The display will return to Σ Σ .
6. Press ZERO to change selection to Σ Σ .
7. Press UNITS to advance.
8. The scale will then show Σ Σ .
9. After the Σ Σ message is displayed, the scale then performs its normal power up routine and enters the Calibration mode. At this time, all the parameters will have been reset to their factory default settings.

Scale Default Settings

When reset to default settings, the CAL menu items, setpoints/outputs, and product ID's are reset. The scale will maintain the calibration settings previously used.

A reference for each CAL menu default value can be found the Scale Parameter Menu Setup, listed in bold.

**Doran Scales, Inc.
883 Enterprise Court
St. Charles, IL 60174**

www.doranscales.com