

AD-8922A

Remote Controller

INSTRUCTION MANUAL

AND

A&D Company, Ltd.

1WMPD4002022A

© 2009 A&D Company Ltd. All rights reserved.

No part of this publication may be reproduced, transmitted, transcribed, or translated into any language in any form by any means without the written permission of A&D Company Ltd.

The contents of this manual and the specifications of the instrument covered by this manual are subject to change for improvement without notice.

CONTENTS

1 INTRODUCTION	4
1 - 1 Outline	4
1 - 2 Applicable Instruments	4
1 - 3 Compliance	5
2 DESCRIPTION OF EACH PART	6
2 - 1 Display	7
2 - 2 Key Operation	7
2 - 3 Connectors	7
3 GETTING READY	8
3 - 1 Setting the Weighing Instrument and the AD-8922A	8
3 - 2 Connecting the AD-8922A	8
3 - 3 Turning the Power on	9
3 - 4 Operation	9
3 - 5 Example of Use	9
4 FUNCTION SETTINGS	11
4 - 1 Display and Keys	11
4 - 2 Function Table	12
4 - 3 Initialization	14
5 TROUBLESHOOTING	15
6 SPECIFICATIONS	16
7 RS-232C SERIAL INTERFACE	17
8 EXTERNAL DIMENSIONS	18
8 - 1 Installing to Wall	19
9 OPTIONS	20
9 - 1 Confirming the AD-8922A Software Version	20
9 - 2 Installing the Option	21
1 0 BCD OUTPUT (AD-8922A-01)	22
1 0 - 1 BCD Output Specifications	22
1 0 - 2 Setting of the Decimal Point Position	27
1 1 COMPARATOR OUTPUT (AD-8922A-04)	28
1 1 - 1 Comparator Output Specifications	28
1 1 - 2 Using the Comparator Output	30
1 1 - 3 Setting the Upper and Lower Limit Values	31
1 2 CURRENT LOOP INPUT (AD-8922A-05)	33
1 2 - 1 Current Loop Input Specifications	33
1 3 ANALOG OUTPUT (AD-8922A-06)	35
1 3 - 1 Analog Output Specifications	35
1 3 - 2 Function setting	37
1 3 - 3 Switching Output Voltage	38
1 3 - 4 Output Voltage Fine Adjustment	38
1 3 - 5 Fixed Output Voltage	39
1 4 ACCESSORIES (CABLE LIST)	40

1 INTRODUCTION

The AD-8922A is a remote controller. Read this manual completely before using the AD-8922A in order to ensure a sufficient understanding for proper use.

1 - 1 Outline

The AD-8922A is connected to an A&D manufactured weighing instrument, using the RS-232C serial interface.

- Displays the weighing data transmitted by the weighing instrument.
- Key operations remotely control the weighing instrument.
(Entering the function setting mode of the weighing instrument is not available. Available operations depend on the weighing instrument used. See Table 2 in "1-2 Applicable Instruments".)
- The data the AD-8922A receives can be output, using the RS-232C serial interface. So, external devices such as a personal computer or a printer can be connected to the AD-8922A.
- Can be panel-mounted.
- Various options such as BCD output, comparator output, current loop input and analog output are available. For details, refer to "9 OPTIONS" and the following relevant chapters.
- When connected to the AD-4212C, the AD-8922A can change the response characteristic, calibrate the AD-4212C using the external weight, and both instruments can share power.
(Power can be supplied to both instruments by plugging the AC adapter into either the AD-4212C or the AD-8922A. For details, refer to "3-3 Turning the Power on".)

1 - 2 Applicable Instruments

Applicable weighing instruments and what is required are shown in the table below.

Table 1 Applicable weighing instruments and what is required

Weighing instrument	What is required to connect to a weighing instrument		Cable required to connect to an external device such as	
	Option for the instrument	Communications cable* (Length 2 m)	Personal computer	AD-8127 compact printer
AD-4212C/D	None (D-Sub 9-pin)	None (Use the cable provided for AD-4212)		
GX, GF, GX-K, GF-K, GP, AD-4212A/B, GR, MC	None (D-Sub 25-pin)	AX-KO1710-200	AX-KO1786-200	AX-KO1786-200
GX-A, GF-A, GX-M, GF-M, EK-i, EW-i, FC-i, FC-Si, GH, HR-i, FZ-i, FX-i, BM, HR-A/AZ	None (D-Sub 9-pin)	AX-KO2466-200		
EJ, HV-C, HV-CP, HW-C, HW-CP	OP-03 (D-Sub 9-pin)	AX-KO2466-200		
HV-G, HV-WP, HW-G, HW-WP	None (DIN 8-pin)	AX-KO1786-200		
FG-L, FG-M	OP-23 (DIN 8-pin)	AX-KO1786-200		

Note (*) - The standard communications cable are AX-KO1710-200 and AX-KO2466-200. A substitute communications cable may be provided as specified when ordering the AD-8922A.

- When connecting to the AD-4212C, use the AX-KO3590-1000 (10m) cable, provided as standard for the AD-4212C.
- When connecting to the AD-4212D, use the AX-KO3590-200 (2m) cable, provided as standard for the AD-4212D.

The AD-8922A functions in two ways as follows, depending on the weighing instrument used:

- A remote controller that displays the weighing data and remotely controls the weighing instrument.
- A remote display that displays the weighing data.

Available key operations depend on the weighing instrument used, as shown below. Set the command set "[5Et]" of the function setting, appropriate to the weighing instrument.

Table 2 Applicable weighing instruments and key operations

Weighing instrument	AD-8922A key						Command set *5
	ON:OFF	CAL	SAMPLE	PRINT	MODE	RE-ZERO	
AD-4212C	Turns the weighing instrument display on or off. *1	Calibrates using the external mass.	Switches the Readability. *2	Outputs the received data to an external device. *3	Switches the response characteristic.	Sets the display to zero.	[5Et] 1
AD-4212D		Calibrates using the internal mass.			Switches the unit displayed. *4		[5Et] 1
GX, GX-A, GX-M, GX-K, GP, GH, FZ-i, MC, BM, HR-AZ			—		—		—
GR		[5Et] 2					
GF, GF-A, GF-M, GF-K, AD-4212A/B, HR-i, FX-i, HR-A		[5Et] 3					
EK-i, EW-i, EJ		—	—		—		[5Et] 4
FC-i, FC-Si, FG-L, FG-M, HV-G, HW-WP, HW-G, HW-WP		—	—		—		—

Note: "—" in the table indicates that the key operation is not available.

*1: Switching the standby or weighing mode is available for the AD-4212C/D.

*2: Not applicable to the counting mode and the percent mode. Switching the Readability is not available for the ET-W.

*3: Available when the AD-8922A is in key mode ("out 1" or "out 2" of the function setting).

*4: Not available for the AD-4212A/B

*5: AD-8922A function settings

1 - 3 Compliance

1 - 3 - 1 Compliance with FCC Rules

Please note that this equipment generates, uses and can radiate radio frequency energy. This equipment has been tested and has been found to comply with the limits of a Class A computing device pursuant to Subpart J of Part 15 of FCC rules. These rules are designed to provide reasonable protection against interference when equipment is operated in a commercial environment. If this unit is operated in a residential area, it may cause some interference and under these circumstances the user would be required to take, at his own expense, whatever measures are necessary to eliminate the interference.

(FCC = Federal Communications Commission in the U.S.A.)

2 DESCRIPTION OF EACH PART

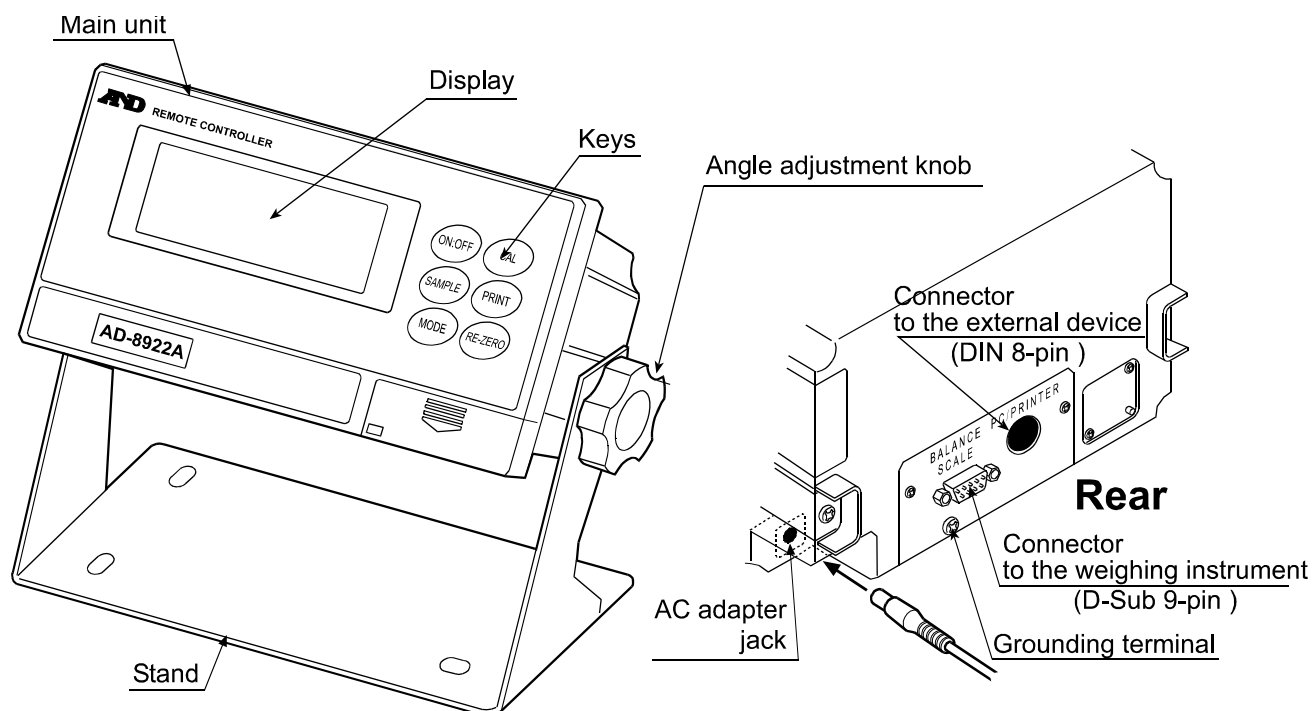

Accessories

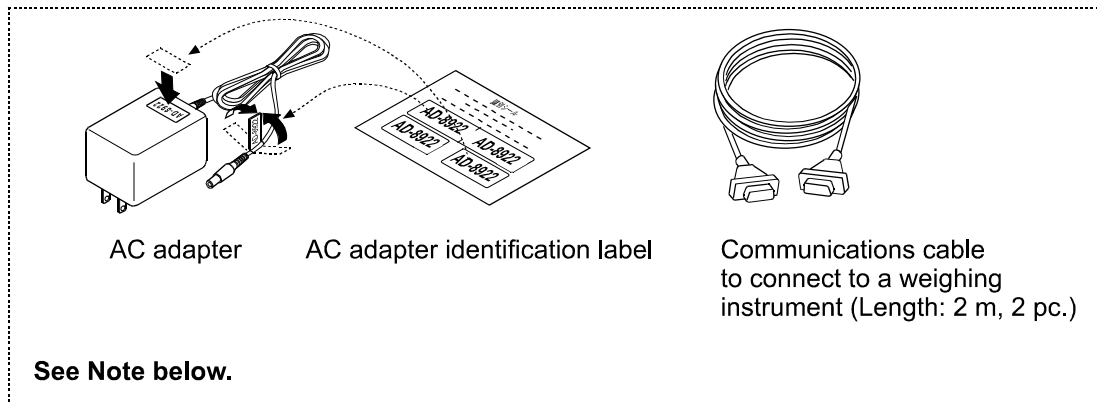

Note: Please confirm that the AC adapter type is correct for your local voltage and receptacle type.

A substitute communications cable, listed below, may be provided as specified when ordering the AD-8922A.

- D-Sub 9-pin to D-Sub 9-pin (AX-KO2466-200)
- DIN 7-pin to D-Sub 9-pin (AX-KO1786-200)

When connecting to the AD-4212C/D, use the cable provided for the AD-4212C/D.

Do not use the cable provided for the AD-8922A.

2 - 1 Display

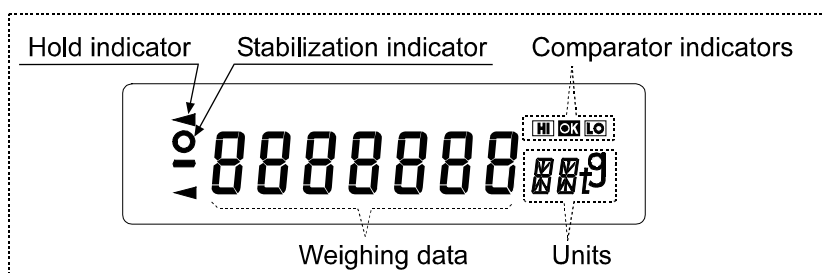

- Displays the weighing data and the unit (or mode) received. The unit (or mode) may be different from that of the weighing instrument.
- Turns on the stabilization indicator when the header of the weighing data received is "ST", "QT", or "WT".
- Turns on the comparator indicator when the comparison results are added to the data received. Applicable to GX-M, GF-M, GX-K, GF-K, GP and AD-4212A/B. (Function setting "[P-r]")
- When nothing has been received for two seconds or more, the bar display [- - - -] appears. By changing the function setting, the previous data received is displayed until the next data is received (Hold display). During the hold display, the hold indicator is turned on.

Note: When the data is in eight digits, the highest-order digit is displayed in the upper left corner as shown below.

For example, if the weighing data is 101.00000 g, the display is like .

2 - 2 Key Operation

Available key operations to control the weighing instrument depend on the weighing instrument used. For details, see Table 2 in "1-2 Applicable Instruments".

Set the command set "[5Et]" of the function setting, appropriate to the weighing instrument.

To enter the function setting mode of the AD-8922A, press and hold the **ON:OFF** key and press the **CAL** key.

The weighing instrument has its own function settings and the AD-8922A can not change those settings.

2 - 3 Connectors

2 - 3 - 1 Connector to the weighing instrument (BALANCE / SCALE) ... D-Sub 9-pin male

Used to connect to the weighing instrument. The cable used for connection depends on the instrument. For details, refer to the instruction manual of the weighing instrument.

2 - 3 - 2 Connector to the external device (PC / PRINTER) ... DIN 8-pin female

Used to connect to an external device such as a personal computer or a printer (AD-8127). The cable used for connection depends on the device. For details, refer to the instruction manual of the device.

3 GETTING READY

3 - 1 Setting the Weighing Instrument and the AD-8922A

1. Set the data output mode of the weighing instrument to "Stream mode".

For other settings, refer to the table below.

Table 3

Item	Weighing instrument	AD-8922A
Baud rate	600, 1200, 2400 , 4800, 9600, 19200 bps	
Data bits, Parity bit	7 bits - EVEN , 7 bits - ODD, 8 bits - NONE	
Stop bits	1 bit or 2 bits	
Terminator	<CR> or <CR><LF>	
Data format	A&D standard format	—
Communication control	No RTS/CTS control	—
Data output mode	Stream mode*	—

Items in bold face type: Factory settings for both the AD-8922A and the weighing instrument.

* When connected to an external device, the settings can be changed to suit the use.

2. Set the command set "ESC" of the function setting, appropriate to the weighing instrument. See Table 2 in "1-2 Applicable Instruments".

Note: Some items may not be available for the instrument used. For details on setting, refer to the instruction manual of each weighing instrument.

When connected to an external device such as a personal computer or a printer, set the output mode "out" and time out "Hold" of the function setting, and set the data output mode of the weighing instrument, appropriate to the use. (See Table 3 in "3-5 Example of Use".)

3 - 2 Connecting the AD-8922A

For information on cables required for connection, see Table 1 in "1-2 Applicable Instruments".

Connect the weighing instrument to the AD-8922A D-Sub 9-pin connector.

Connect an external device such as a personal computer or a printer to the AD-8922A DIN 8-pin connector.

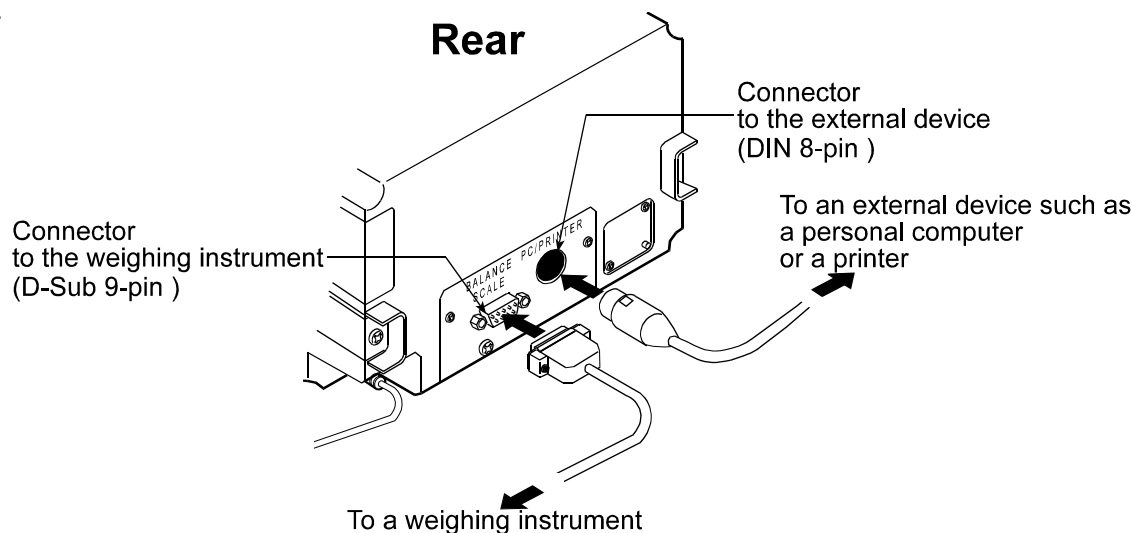

3 - 3 Turning the Power on

Insert the AC adapter plug into the AC adapter jack located on the rear of the AD-8922A. Plug the AC adapter into an appropriate electrical outlet.

When connected to the following instruments, power can be supplied to both instruments by plugging the AC adapter into either the weighing instrument or the AD-8922A.

(Both instruments can have their AC adapter connected at the same time.)

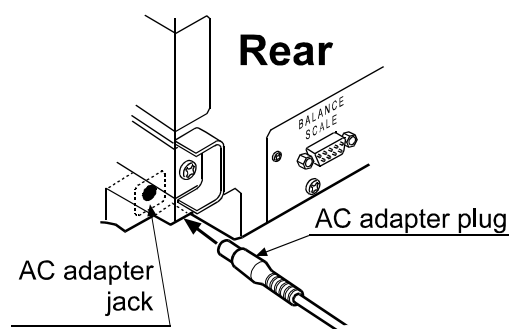

Compatible instruments: AD4212C/D, GX-A, GF-A, GX-M, GF-M, HR-A/AZ

3 - 4 Operation

- The AD-8922A displays the weighing data transmitted by the weighing instrument used.
- The AD-8922A key operations remotely control the weighing instrument.

Available operations depend on the weighing instrument. See Table 2 in "1-2 Applicable Instruments".

3 - 5 Example of Use

- A personal computer is connected to the AD-8922A and the weighing data can be transmitted to the personal computer, using Windows communication tools (WinCT).
- To protect against inadvertent operations, the AD-8922A keys can be disabled. (Function setting "CSEt 0").
- When nothing has been received for two seconds or more, the bar display [- - - -] appears. By changing the function setting, the previous data received is displayed until the next data is received (Hold display). (Function setting "HoLd 1")
- About details on the settings of the weighing instrument or the external device, see the relevant instruction manual.

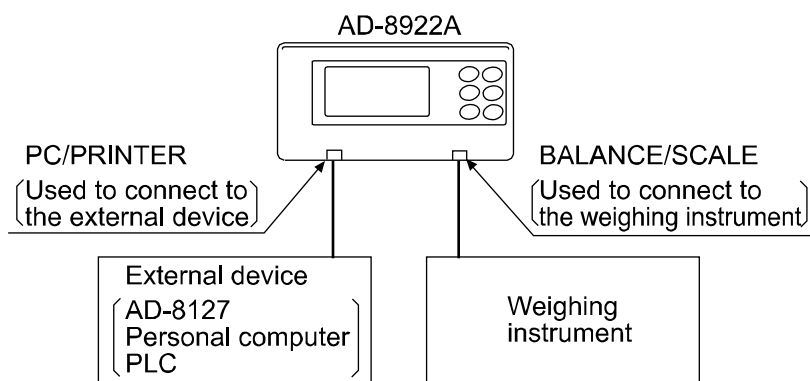

Table 4 Use of the AD-8922A

Example of use	Weighing instrument	AD-8922A setting			External device setting
Monitors the weighing data of the weighing instrument remotely.	Stream mode (Outputs the weighing data continuously.)	Through mode	"out 0"	Sends all of the received weighing data to the external device.	[AD-8127] MAMUAL (Prints data when the AD-8127 <input type="text" value="0"/> (PRINT) key is pressed.)
		Key mode 1	"out 1"	When the AD-8922A <input type="text" value="PRINT"/> key is pressed, sends the latest weighing data received to the external device, regardless of the data status.	[AD-8127] EXT.KEY (Prints data when the AD-8922A <input type="text" value="PRINT"/> key is pressed.)
		Key mode 2	"out 2"	When the AD-8922A <input type="text" value="PRINT"/> key is pressed, sends the latest weighing data received to the external device when the data is stable.	
	Key mode or Auto print mode (Outputs the weighing data when the key is pressed or outputs the data automatically when stable.)	Through mode	"out 0"	Sends all of the received weighing data to the external device.	[AD-8127] EXT.KEY (Prints data according to the data output mode of the weighing instrument.)
Monitors the weighing data of the weighing instrument that is built into a weighing system.	Command mode * (Outputs the weighing data by the data request command.)	Through mode	"out 0"	Sends all of the received weighing data to the external device.	[Personal computer or PLC] (The program to control the device is required.)

* The command mode may not be available for weighing instruments of which command is always valid.

4 FUNCTION SETTINGS

The function settings specify the parameters for the AD-8922A performance. These parameters stored, even if the AC adapter is removed, are maintained in non-volatile memory.

The function menu consists of two layers. The first layer is the “Class” and the second layer is the “Item”. Each item is selected by the **SAMPLE** key. The parameter of the selected item is changed by the **RE-ZERO** key. Finally, the parameter is stored and is enabled by the **PRINT** key.

Example

This example sets “9600 bps” for “Baud rate” and “8 bits NONE” for “Data bits, parity bit”.

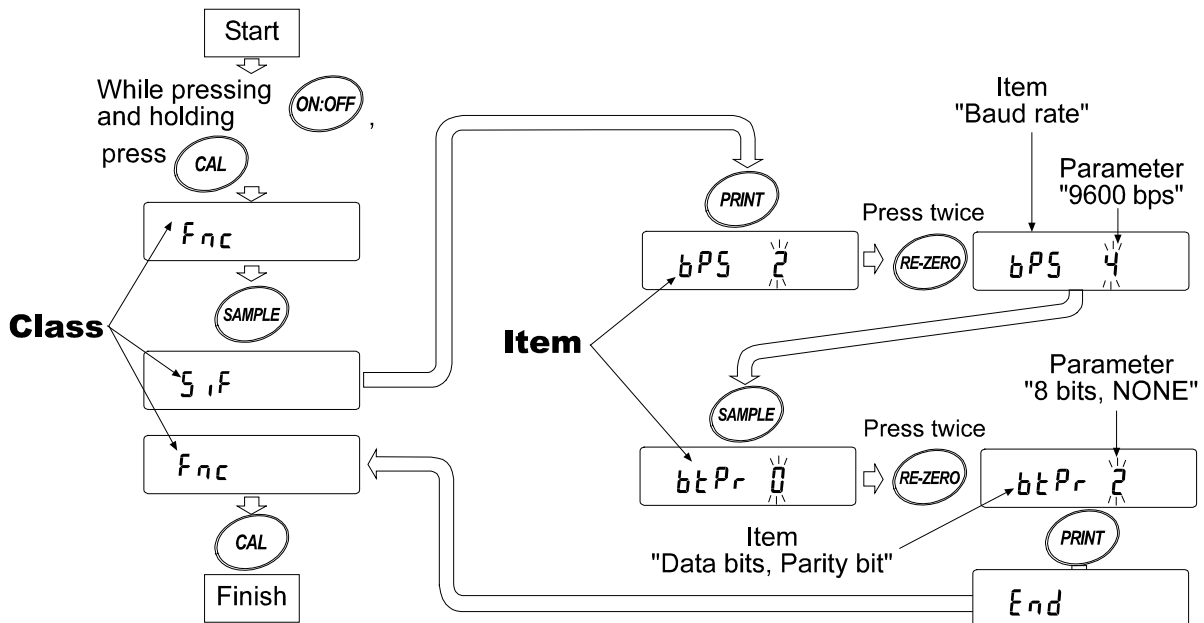

Note: Use much care when changing parameters. The AD-8922A may not function properly when the settings and operational environment are not appropriate.

4 - 1 Display and Keys

Table 5

Display/Key	Description
	The symbol “○” indicates that the parameter displayed is in effect.
SAMPLE	Selects the class or item in the function setting mode.
RE-ZERO	Changes the parameter.
PRINT	When a class is displayed, moves to an item in the class. When an item is displayed, stores the new parameter and displays the next class.
CAL	When an item is displayed, cancels the new parameter and displays the next class. When a class is displayed, exits the function setting mode.

4 - 2 Function Table

Table 6

Class	Item	Parameter	Description		
<i>Fnc</i> Environment Display	<i>[SET]</i> Command set	0	Set 0	See Table 2 in "1.2 Applicable Instruments".	
		▪ 1	Set 1		
		2	Set 2		
		3	Set 3		
		4	Set 4		
	<i>out</i> Output mode	0	Through mode	Always outputs the data received by the D-Sub 9-pin connector, to the DIN 8-pin connector.	
		1	Key mode 1	Outputs the latest data received by the D-Sub 9-pin connector, to the DIN 8-pin connector, when the AD-8922A [PRINT] key is pressed.	
		▪ 2	Key mode 2	Outputs the latest stable data received by the D-Sub 9-pin connector, to the DIN 8-pin connector, when the AD-8922A [PRINT] key is pressed.	
	<i>Hold</i> Timeout	▪ 0	Bar display	Bar display if nothing has been received for two seconds or more.	
		1	Hold display	Displays the previous data received if nothing has been received for two seconds or more, and turns on the hold indicator.	
	<i>bEP</i> Data receipt buzzer	▪ 0	Not used	No buzzer upon data receipt.	
		1	At intervals	Sounds buzzer when the data is received with an interval of two seconds or more.	
		2	Used	Sounds buzzer upon each data receipt.	
	<i>dPP</i> Position of decimal point	▪ -	Not set	Sets the decimal at a specific position. When changing the Readability pressing [SAMPLE] key does not change the decimal point position. (For details, refer to "10-2".)	
		0 1 6	Set		
	<i>SAPL</i> Function of the SAMPLE key	0	No function	The [SAMPLE] key does not function.	
		▪ 1	Function	The [SAMPLE] key will function.	
	<i>SIF</i> Serial interface	<i>bPS</i> Baud rate	0	600 bps	Choose a parameter appropriate to the weighing instrument. When the AD-8127 compact printer is to be connected, leave the factory settings of the AD-8922A as is and set the weighing instrument.
			1	1200 bps	
			▪ 2	2400 bps	
3			4800 bps		
4			9600 bps		
5			19200 bps		

▪ Factory setting

Class	Item	Parameter	Description	Class
S _{IF} Serial interface	b _{tPr} Data bits	▪ 0	7 bits - EVEN	Choose a parameter appropriate to the weighing instrument. When the AD-8127 compact printer is to be connected, leave the factory settings of the AD-8922A as is and set the weighing instrument.
		1	7 bits - ODD	
	Parity bit	2	8 bits - NONE	
	S _{toP} Stop bits	▪ 0	1 bit	
		1	2 bits	
	C _{rLF} Terminator	▪ 0	CR/LF	
1		CR		
bcd BCD (Available only when the BCD output is installed.)	d _{AtA} data	0	ON when 0	
		▪ 1	ON when 1	
	P _{oLP} Polarity	▪ 0	ON when positive or 0	
		1	ON when negative	
	S _{tStP} Stability	0	ON when the stabilization indicator is turned off	
		▪ 1	ON when the stabilization indicator is turned on	
	O _{ErP} Over	0	OFF when E or -E	
		▪ 1	ON when E or -E	
	S _{trP} Strobe	0	Data refresh is complete when ON → OFF	
		▪ 1	Data refresh is complete when OFF → ON	
S _{trt} Strobe pulse width	▪ 0	Approx. 10 ms	Strobe pulse width after data refresh	
	1	Approx. 20 ms		
	2	Approx. 50 ms		
S _{trP} (Input terminal function)	▪ 0	BUSY input function		
	1	RE-ZERO input function		
C _{P Fnc} Comparator (Available only when the comparator output is installed.)	C _P Comparator mode	▪ 0	No comparison	
		1	Comparison, excluding "near zero" when the value is stable or overloaded	
		2	Comparison, including "near zero" when the value is stable or overloaded	
		3	Continuous comparison, excluding "near zero"	
		4	Continuous comparison, including "near zero"	
	5	Contact-outputs the second header information of the data received. (Applicable to AD-4212A, GP and GX-K)		
	b _{EP-} LO buzzer	▪ 0	OFF	Selects whether or not to sound the buzzer when LO.
		1	ON	
	b _{EP-} OK buzzer	▪ 0	OFF	Selects whether or not to sound the buzzer when OK.
		1	ON	
b _{EP-} HI buzzer	▪ 0	OFF	Selects whether or not to sound the buzzer when HI.	
	1	ON		
R _{out} Analog output (Available only when the analog output is installed.)	R _n Analog output mode	▪ 0	2-digt output	Converts the consecutive 2 digits, with the digit selected in SEL as the least, to voltage and outputs.
		1	3-digt output	Converts the consecutive 3 digits, with the digit selected in SEL as the least, to voltage and outputs.
	SEL Analog output digit selection	▪ 0	Selects the first digit as the least.	
		1	Selects the second digit as the least.	
		2	Selects the third digit as the least.	
		3	Selects the fourth digit as the least.	
		4	Selects the fifth digit as the least.	
		5	Selects the sixth digit as the least.	

▪ Factory setting

4 - 3 Initialization

Initialization restores the AD-8922A function settings to factory settings.

1. Connect the AC adapter. The bar display or the weighing data display appears.
2. While pressing and holding the **ON:OFF** key, press the **PRINT** key. "[Lr" appears in the display.
3. Press the **PRINT** key. (To cancel the operation, press the **CAL** key.)
4. Press the **RE-ZERO** key to select "G0".
5. Press the **PRINT** key to perform initialization.
After initialization, the bar display or the weighing data display appears.

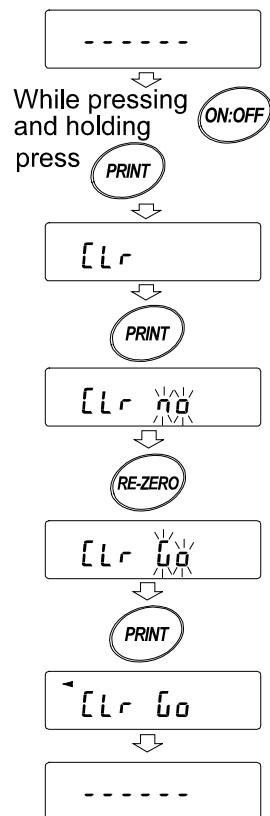

5 TROUBLESHOOTING

Shown below is a list of various phenomena of the AD-8922A and the remedies.

Table 7

Phenomenon	Cause and remedy
<i>Error 10</i> appears.	<ul style="list-style-type: none"> The communications settings of the AD-8922A and the weighing instrument are not the same. Check the settings.
<i>Error 11</i> appears.	<ul style="list-style-type: none"> The weighing instrument data format is incorrect. Set the data format to A&D standard format. Also check whether or not data other than weighing data is output.
The [- - - -] display remains and no weighing data appears.	<ul style="list-style-type: none"> Is the weighing instrument in the stream mode? Only the stream mode displays the weighing data continuously. Other modes display the data only when received. When the hold display is selected in the AD-8922A function setting, the previous data received is displayed until the next data is received. Are the communications settings correct? Is the cable correct?
The display flickers.	<ul style="list-style-type: none"> Electrical noises may affect the display. Using the grounding terminal located on the rear of the AD-8922A, ground the AD-8922A.

6 SPECIFICATIONS

Power supply	: AC adapter (Please confirm that the AC adapter type is correct for your local voltage and receptacle type.)
Power consumption	: Approx.30 VA (Including the AC adapter, AD-8922A: approx. 1.5 VA)
Transmission system	: RS-232C
Baud rate	: 600, 1200, 2400, 4800, 9600, 19200 bps
Refresh rate	: Approx. 10 times/second (When Baud rate is 2400 bps or greater).
Applicable connectors	: D-Sub 9-pin (Male) to connect to the weighing instrument DIN 8-pin (Female) to connect to an external device
Dimensions	: 238 (W) x 132 (D) x 170 (H) mm
Mass	: Approx. 1.0 kg
Standard accessories	: AC adapter, Communications cable (Approx. 2 m) (Please confirm that the AC adapter type is correct for your local voltage and receptacle.)

7 RS-232C SERIAL INTERFACE

RS-232C

Transmission system : EIA RS-232C
 Transmission form : Asynchronous, bi-directional, half duplex
 Data format : Baud rate : 600, 1200, 2400, 4800, 9600, 19200 bps
 Data bits : 7 bits or 8 bits
 Parity bit : EVEN, ODD (Data bits 7 bits)
 NONE (Data bits 8 bits)
 Stop bits : 1 bit or 2 bits
 Code : ASCII
 Terminator : <CR> or <CR><LF>

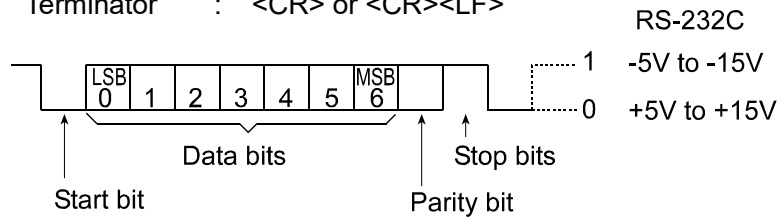

Circuit

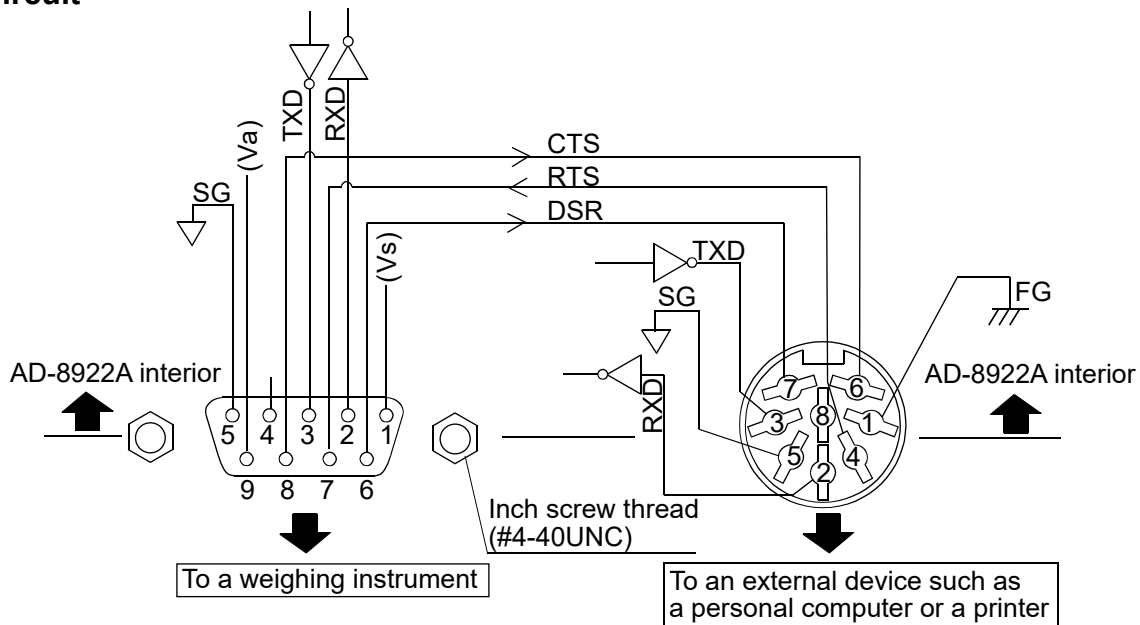

Connection to the weighing instrument

D-Sub 9-pin (male)

Pin No.	Signal name	Direction	Description
1	(Vs)	—	Used internally
2	RXD	Input	Receive data
3	TXD	Output	Transmit data
4	—	—	N.C.
5	SG	—	Signal ground
6	DSR	Input	Data set ready
7	RTS	Output	Request to send
8	CTS	Input	Clear to send
9	(Va)	—	Used internally

(AD-8922A is a DTE. Connects to a DCE such as a weighing instrument using a straight through cable.)

When making the cable yourself, do not connect to the internally used terminals.

Connection to an external device

DIN 8-pin (female)

Pin No.	Signal name	Direction	Description
1	FG	—	Frame ground
2	RXD	Input	Receive data
3	TXD	Output	Transmit data
4	RTS	Input	Request to send
5	SG	—	Signal ground
6	CTS	Output	Clear to send
7	DSR	Output	Data set ready
8	—	—	N.C.

(The signal names except TXD and RXD apply to the DTE such as a personal computer.)

8 EXTERNAL DIMENSIONS

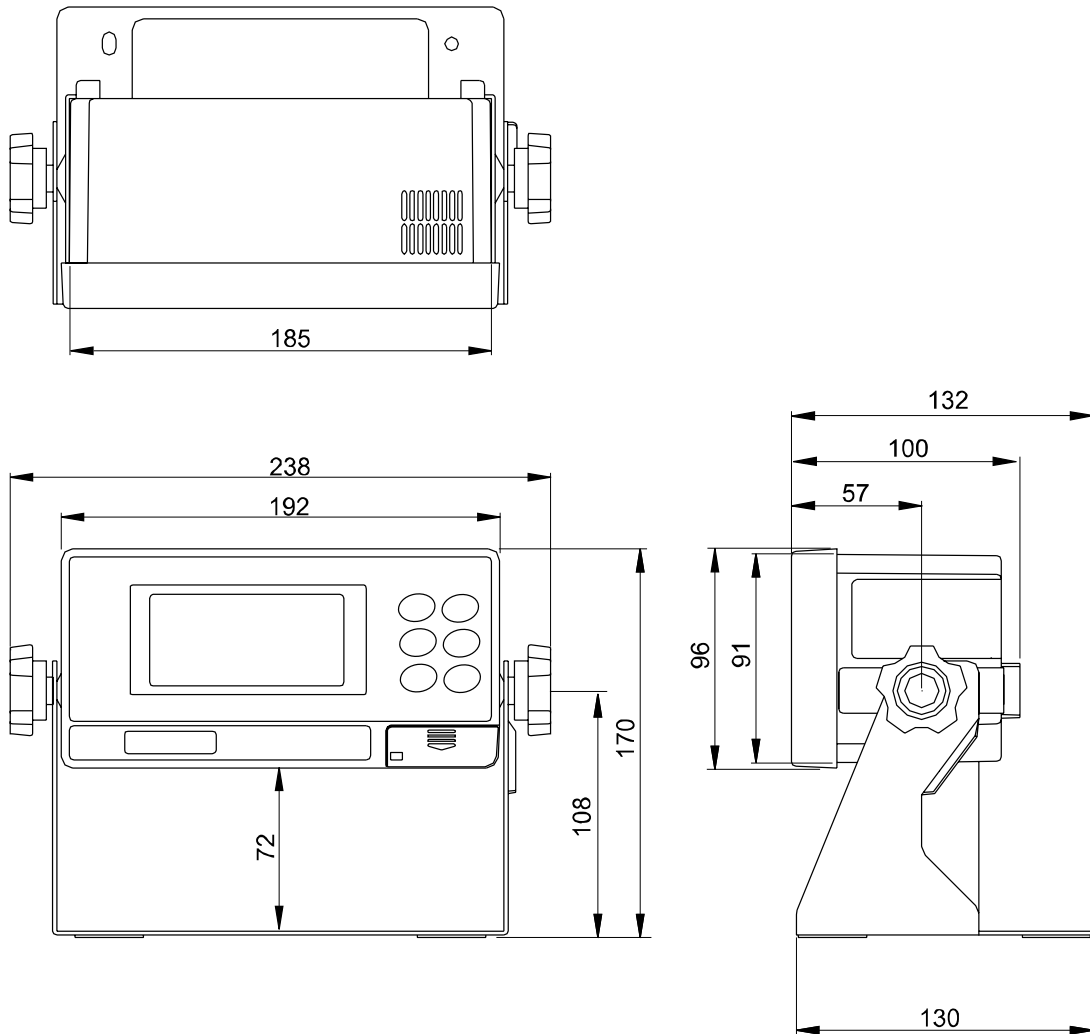

Unit: mm

8 - 1 Installing to Wall

Installing the display unit on a wall using the standard stand

1. Secure the stand, that is attached to the display unit, on the wall using the four screws.
2. Adjust the angle of the display unit and tighten the angle adjustment knobs located on both sides of the display unit.

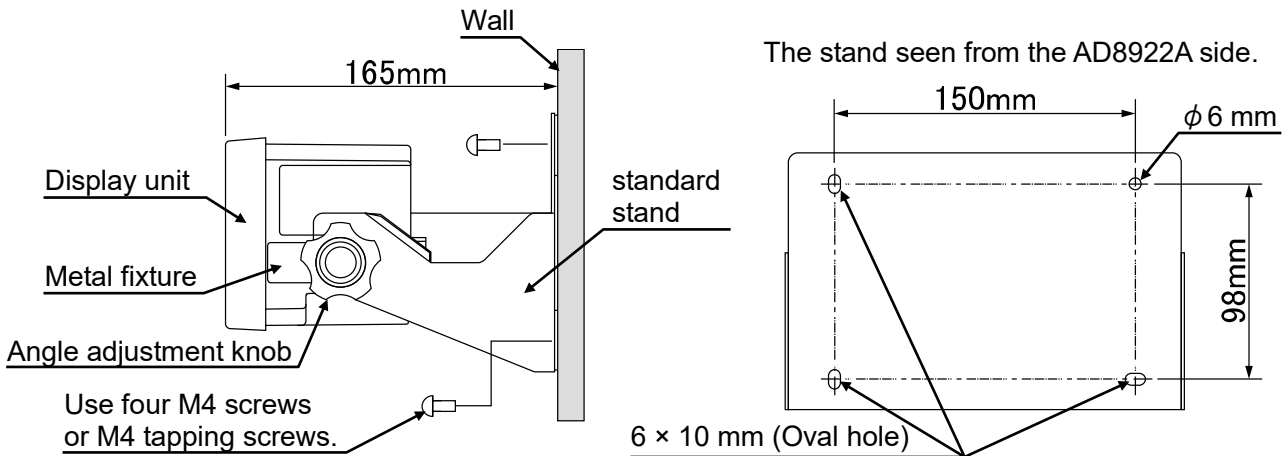

Installing in a panel

1. Cut the panel according to the size of the display unit.
2. Remove the angle adjustment knobs located on both sides of the display unit and remove the standard stand.
3. Remove the screws (one on each side) that secure the metal fixtures from rear side of the display unit and pull the metal fixtures out.
4. Insert the display unit from the front side of the panel.
5. From the rear side of the panel, insert the metal fixtures in the channels located on both sides of the display unit, and secure it with the screws (one on each side).

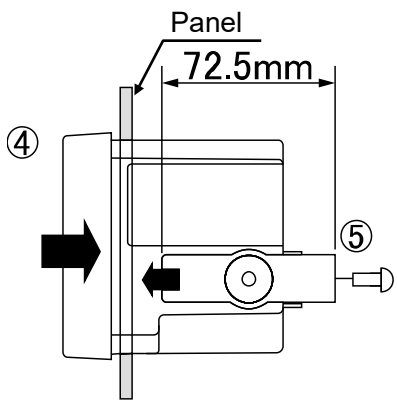
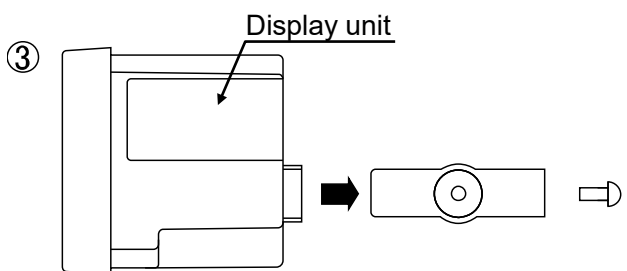
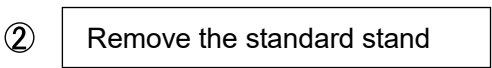
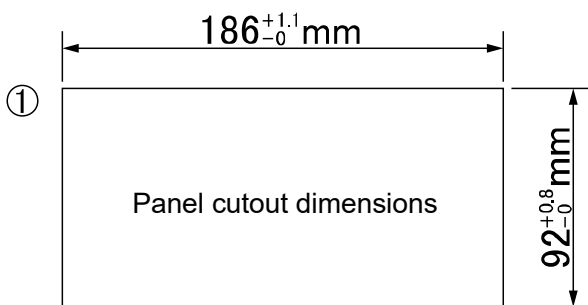
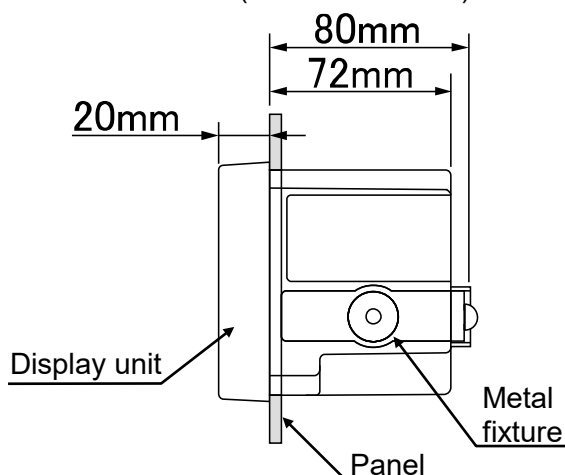

9 OPTIONS

The AD-8922A has various options available as follows.

For details on each option, refer to the relevant chapter.

- AD-8922A-01 BCD output
Outputs the weighing data received from the weighing instrument using the RS-232C serial interface, in BCD format.
- AD-8922A-04 Comparator output
Compares the weighing data received from the weighing instrument using the RS-232C serial interface with the upper or lower limit value and contact-outputs the results.
When connected to the AD-4212C, the both instruments can share power.
Note: When connected to the AD-4212C, the both instruments can not be shared power.
- AD-8922A-05 Current loop input
Receives the current loop output from the weighing instrument and displays the weighing data.
The weighing data received can be output using the RS-232C serial interface.
The AD-4212C does not have current loop output. Therefore, this option can not be used.
- AD-8922A-06 Analog output
Converts the specified digits of the weighing data received from the weighing instrument, using the RS-232C serial interface, into voltage and outputs the value.

Note: When connected to the AD-4212C, the both instruments can not be shared power.

9 - 1 Confirming the AD-8922A Software Version

Before installing an option, confirm the AD-8922A software version.

The software version is displayed as "P_nx.xx" for approx. 1 second before entering the function setting mode.

9 - 2 Installing the Option

Install the option as shown below. The installation procedure is the same for all the options.

1. Disconnect the AC adapter.

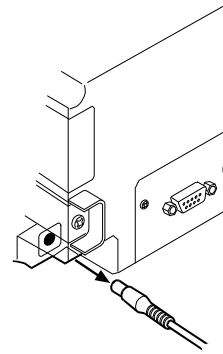

2. Remove the two screws and pull out the RS-232C board provided as standard as shown in the illustration.

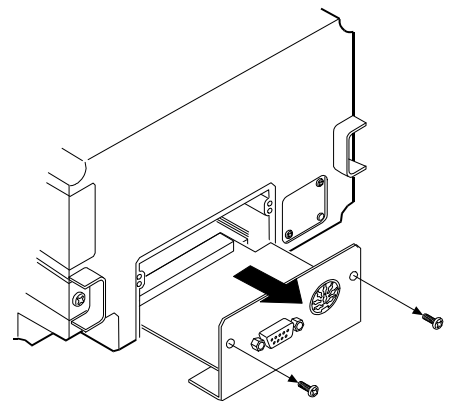

3. Insert the option board, along the guides on the left and right sides.

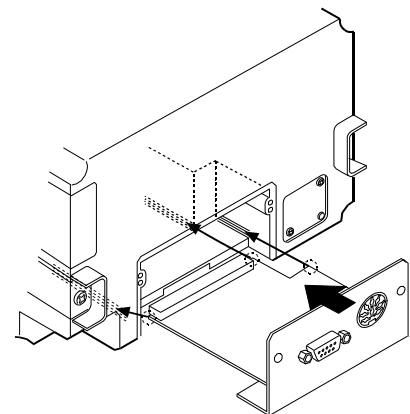

4. Using the two screws removed in step 2, fasten the option board.

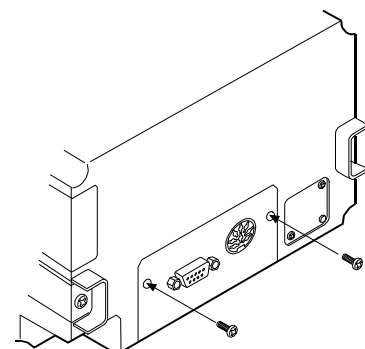

1 0 BCD OUTPUT (AD-8922A-01)

Outputs the weighing data received from the weighing instrument in BCD format, along with the polarity (+/-) and the data status (stable/unstable and over/under).

Using the STROBE signal, the data can be read easily. The AD-8922A-01 can set the input terminal function to either the BUSY or the RE-ZERO input function by selecting that function. When set to the RE-ZERO input function, the AD-8922A transmits the RE-ZERO command to the weighing instrument, setting the weighing value to zero. BUSY input enables the data to be held or prevents data refreshing during the reading operation.

The logic of data, status and strobe can be switched in the function setting.

Note: When the AD-8922A-01 is installed, the RS-232C serial interface can not be used.

When connected to the AD-4212C, the both instruments can share power.

For details about the RE-ZERO function of the applicable weighing instruments, refer to RE-ZERO of Table 2 in "1-2 Applicable Instruments".

1 0 - 1 BCD Output Specifications

Accessories

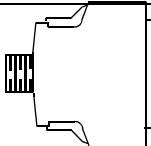
I/O plug applicable to the BCD output port	1 pc.	
Instruction manual	1 copy	
Cable to connect to a weighing instrument (Length: Approx. 2 m)	1 pc.	
D-Sub 25-pin to DIN 7-pin (AX-KO577A-200)		

Note: A substitute cable may be provided as specified when ordering the AD-8922A.

D-Sub 9-pin to DIN 7-pin (AX-KO1786-200)

DIN 7-pin to DIN 7-pin (AX-KO507-W200)

A round waterproof 12-pin to DIN 7-pin (AX-KO3705-500)

The communications cable provided for the AD-4212C (5m)

Note: When the AD-8922A-01 is installed, the communications cable provided with the AD-8922A will not be used.

Panel view

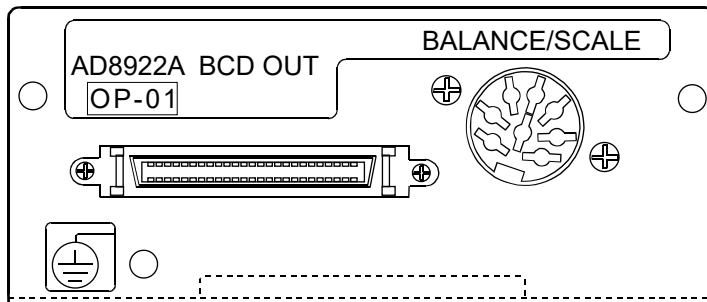

BCD output port (BCD-OUT)

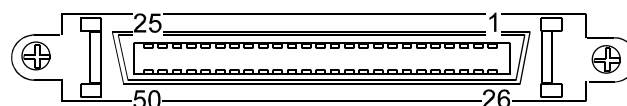

Half pitch 50 pin

Plug (Provided)

Part name	Product number	Manufacturer
Over mold cover	DX30M-50-CV	Hirose Electric
Plug unit (Soldered type)	DX40M-50P	

Note: The products above are subject to be replaced with the equivalent.

Cable

Wire size	AWG #28
Core configuration	7/0.127
O.D. of insulator	0.58

Pin assignments and I/O logic

Output pin assignments		
Pin No.	Signal	
26	1	10 ⁰
27	2	
28	4	
29	8	
39	1	10 ¹
40	2	
41	4	
42	8	
12	1	10 ²
13	2	
14	4	
15	8	
16	1	10 ³
17	2	
18	4	
19	8	
20	1	10 ⁴
21	2	
22	4	
23	8	
46	1	10 ⁵
47	2	
48	4	
49	8	
24	1	10 ⁶
25	2	
30	4	
31	8	
32	1	10 ⁷
33	2	
34	4	
35	8	
50	Polarity	Status
45	Stability	
44	Over	
43	Strobe	
1	Output signal GND	

Input pin assignments	
Pin No	Signal
7	BUSY/RE-ZERO
3	Input signal GND

-The pins, which are not specified, have no connection.

Output logic

Output	Factory settings	
Data	1	ON
Polarity	Positive or zero	ON
Stability	Stabilization indicator ON	ON
Over	E, -E	ON

- All output, open collector; withstand voltage 30 V; no pull-up resistor; low-level output current 48 mA
- Output logic of data, status, and strobe can be switched individually in the function table *bcd*.

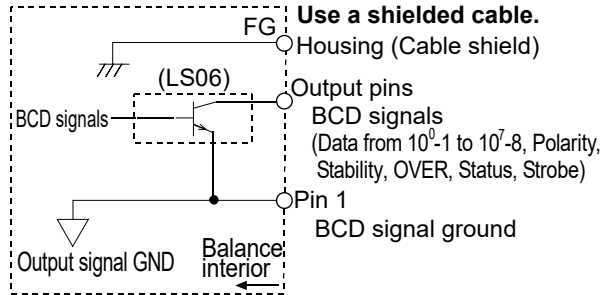

Input logic

Input	
BUSY	Data will be held during ON (when connected to input signal GND).
RE-ZERO	RE-ZERO will be performed with ON (when connected to input signal GND).

- All input, no voltage contact or open collector (connected to 5 V internally)
- BUSY and RE-ZERO use same input terminal, set it by the function.

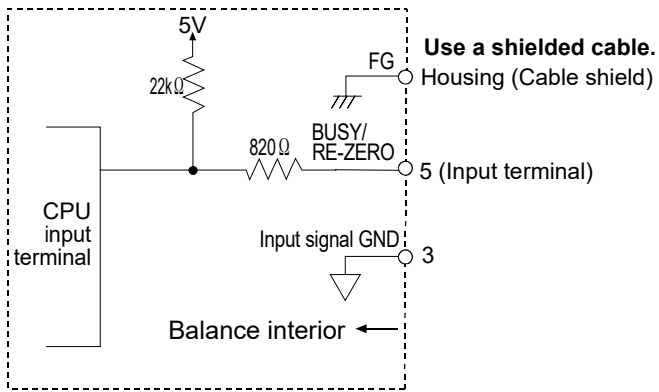

(1) When a switch is used

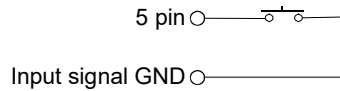

(2) When a photocoupler is used

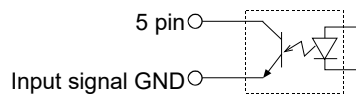

(3) When a transistor is used

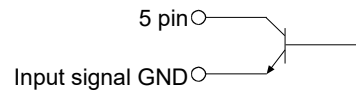

(Upon switch-ON, make the voltage between the input terminal and the input signal GND terminal 0.2V or less)

Output example

Display

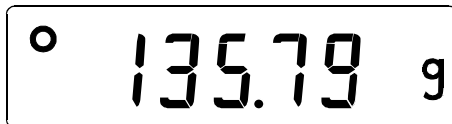

BCD output

The example above is when the output logic has been set at the factory.

The decimal point information will not be output.

Output pin assignments		
Pin No.	Signal	Output
26	1	1
27	2	0
28	4	0
29	8	1
39	1	1
40	2	1
41	4	1
42	8	0
12	1	1
13	2	0
14	4	1
15	8	0
16	1	1
17	2	1
18	4	0
19	8	0
20	1	1
21	2	0
22	4	0
23	8	0
46	1	0
47	2	0
48	4	0
49	8	0
24	1	0
25	2	0
30	4	0
31	8	0
32	1	0
33	2	0
34	4	0
35	8	0
50	Polarity	1
45	Stability	1
44	Over	0

0:OFF

1:ON

I/O timing chart

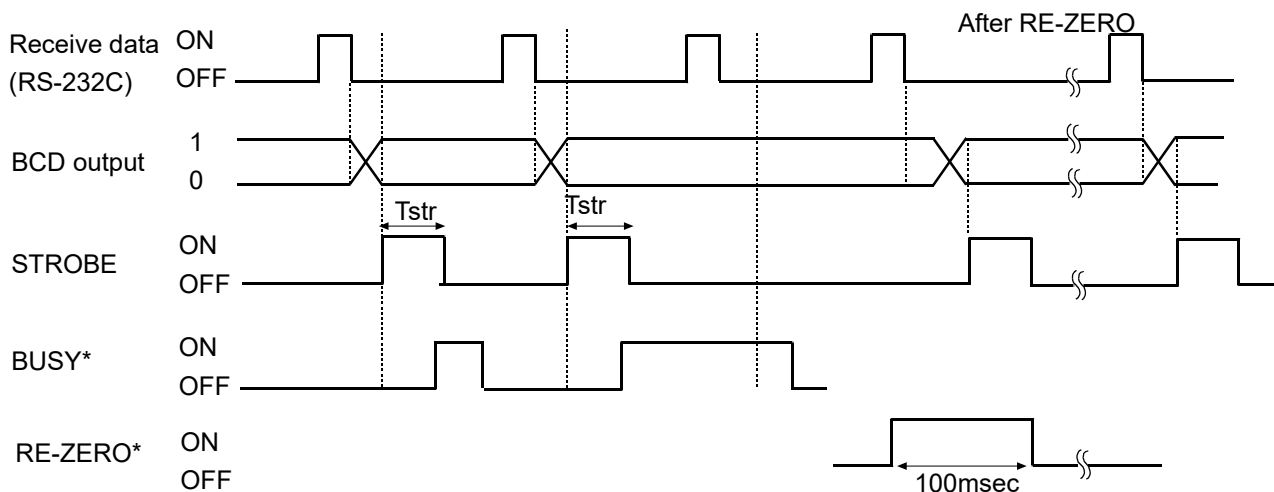

The factory setting of T_{str} (Strobe pulse width) is approx. 10 ms. It can be changed to approx. 20 ms or approx. 50 ms in the function setting of "St_{rt}".

- * -"BUSY/RE-ZERO input ON" is the condition that BUSY is connected to input signal GND (Pin 3).
- The AD-8922A-01 can select either the BUSY input or the RE-ZERO input by setting the function.
- When keeping the on state for 100msec, the weighing instruments keep the re-zero state.

RS-232C (BALANCE/SCALE)

Transmission system : EIA RS-232C
 Transmission form : Asynchronous, bi-directional, half duplex
 Data format : Baud rate : 600, 1200, 2400, 4800, 9600, 19200bps
 Data bits : 7 or 8 bits
 Parity : Even, Odd (Data bits 7 bits)
 None (Data bits 8 bits)
 Stop bit : 1 or 2 bits
 Code : ASCII
 Terminator : <CR> or <CR><LF>

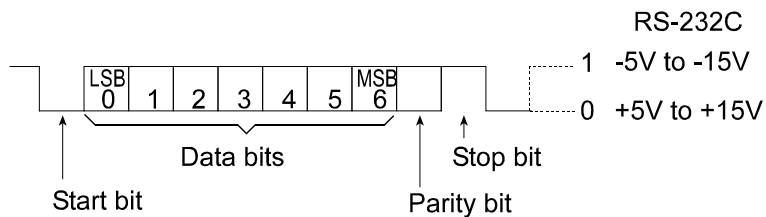

Circuit

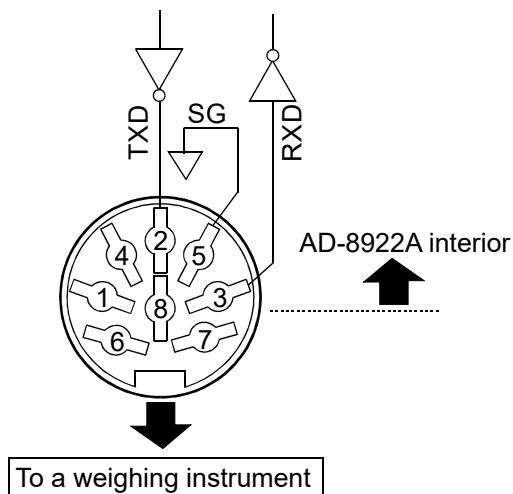

DIN 8-pin

Pin assignment (BALANCE/SCALE)

Pin No.	Signal name	Direction	Description
1	(Vs)	—	Internally used
2	TXD	Output	Transmit data
3	RXD	Input	Receive data
4	—	—	—
5	SG	—	Signal ground
6	(Va)	—	Internally used
7	—	—	—
8	—	—	—

When making the cable yourself, do not connect to the internally used terminals.

1 0 - 2 Setting of the Decimal Point Position

The AD-8922A can set the display digit and the BCD output digit by setting d^{PP} of the function. When setting the decimal point position, the BCD output digit does not change if changing the Readability by pressing the **SAMPLE** key.

Example 1) When not setting the decimal point position ($d^{PP} -$) [Factory setting]

(Key operation)	Balance display	AD-8922A display	BCD output
	° 123.45 g	° 123.45 g	0 0 0 1 2 3 4 5
	° 123.456 g	° 123.456 g	0 0 1 2 3 4 5 6

* When changing the Readability by pressing **SAMPLE** key, the BCD shifts the output left and adds the last digit.

Example 2) When setting the decimal point at the third digit position. ($d^{PP} 3$)

(Key operation)	Balance display	AD-8922A display	BCD output
	° 123.45 g	° 123.45 g	0 0 1 2 3 4 5 0
	° 123.456 g	° 123.456 g	0 0 1 2 3 4 5 6

* When changing the Readability by pressing **SAMPLE** key, the BCD output does not change the number of digits.

1 1 COMPARATOR OUTPUT (AD-8922A-04)

The weighing data is compared with the upper and lower limit values and the results of the comparison are contact-output in three levels of **HI** **OK** **LO**. The upper and lower limit values are set in the function setting. Whether or not to sound the buzzer according to the results can be selected.

Note: When the AD-8922A-04 is installed, the pin assignment (DIN 8-pin), of the RS-232C serial interface, to connect an external device, will be changed.

When connected to the AD-4212C, the both instruments can not be shared power.

1 1 - 1 Comparator Output Specifications

Accessories

DIN connector (Plug) 1 pc. 

Instruction manual 1 copy

Panel view

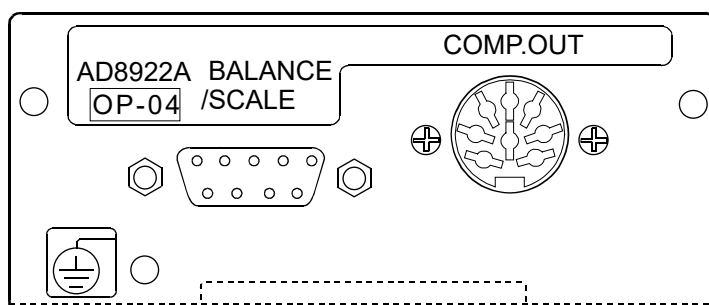

Comparator output (COMP.OUT)

Maximum contact voltage: 100 VDC

Maximum contact current: 100 mA DC

Maximum contact resistance: 20 Ω

Comparator output judgement conditions (when upper limit value \geq lower limit value):

Weighing data $>$ upper limit value: Activates the HI comparator output.

Upper limit value \geq weighing data \geq lower limit value: Activates the OK comparator output.

Weighing data $<$ lower limit value: Activates the LO comparator output.

Reference value setting: Input the upper and lower limit values digitally.

Contact output: Select whether or not to compare, using "CP" of the function setting.

Buzzer: Select whether or not to sound the buzzer, using "bEP" of the function setting.

RS-232C

Transmission system : EIA RS-232C
 Transmission form : Asynchronous, bi-directional, half duplex
 Data format : Baud rate : 600, 1200, 2400, 4800, 9600, 19200 bps
 Data bits : 7 bits or 8 bits
 Parity bit : EVEN, ODD (Data bits 7 bits)
 NONE (Data bits 8 bits)
 Stop bits : 1 bit or 2 bits
 Code : ASCII
 Terminator : <CR> or <CR><LF>

RS-232C

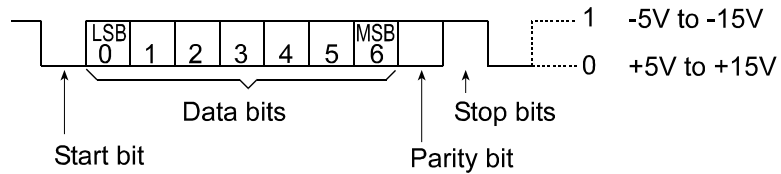

Circuit

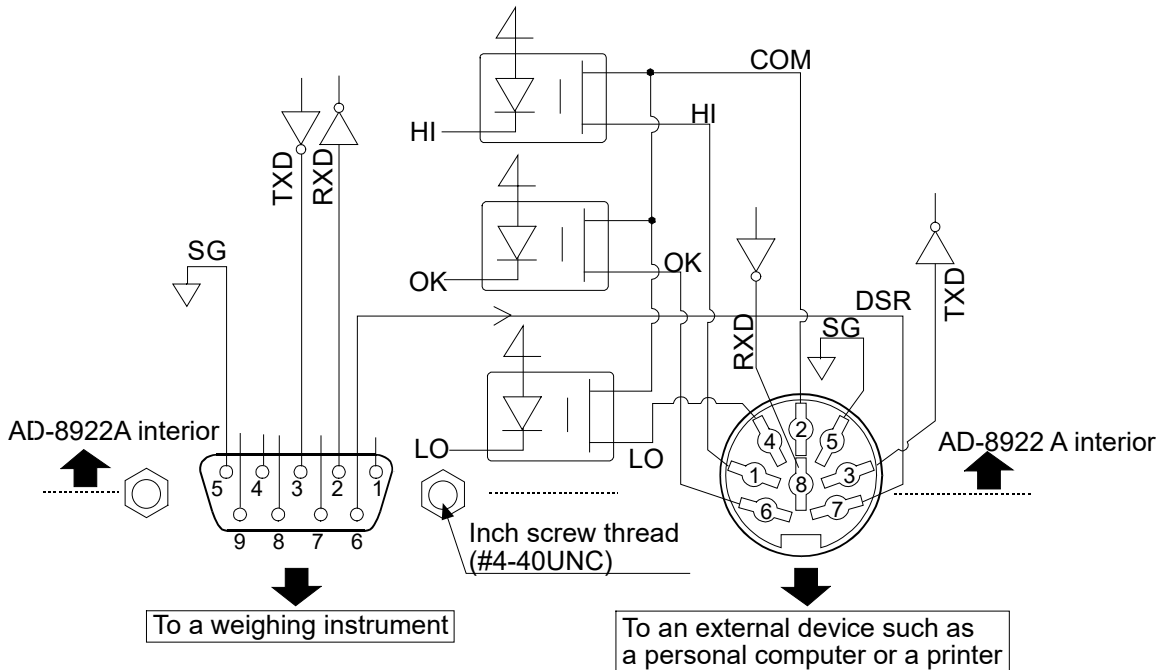

Connection to the weighing instrument

D-Sub 9-pin (BALANCE/SCALE)

Pin No.	Signal name	Direction	Description
1	—	—	N.C.
2	RXD	Input	Receive data
3	TXD	Output	Transmit data
4	—	—	N.C.
5	SG	—	Signal ground
6	DSR	Input	Data set ready
7	RTS	Output	Request to send
8	—	—	N.C.
9	—	—	N.C.

(AD-8922A is a DTE. Connects to a DCE such as a weighing instrument using a straight through cable.)

Connection to an external device

DIN 8-pin (COMP.OUT)

Pin No.	Signal name	Description
1	HI	HI contact-output
2	COM	COM contact-output
3	TXD	Transmit data (RS-232C output)
4	LO	LO contact-output
5	SG	Signal ground
6	OK	OK contact-output
7	DSR	Data set ready (RS-232C output)
8	RXD	Receive data (RS-232C output)

1 1 -2 Using the Comparator Output

To use the comparator output, perform the following four steps.

1. Connect the peripheral to the AD-8922A-04 DIN connector.
2. Set the “Comparator ($\overline{CP} F_{nc}$)” of the AD-8922A function setting. For details, see “4. FUNCTION SETTINGS”.
3. Set the upper and lower limit values. For details, see “11-3 Setting the Upper and Lower Limit values”.
4. When the weighing data is received, the comparison results will be output.

When the weighing data is equal to or less than the upper limit value, and equal to or greater than the lower limit value, the OK comparator will be output.

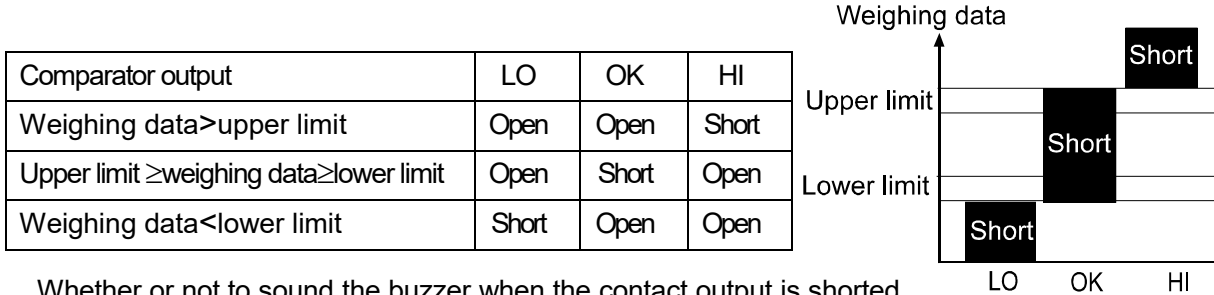

Whether or not to sound the buzzer when the contact output is shorted can be set in the “Buzzer mode (bEP)” of the “Comparator ($\overline{CP} F_{nc}$)”.

Note: When setting the upper and lower limit values, make sure that the upper limit value is greater than the lower limit value.

Function setting

The function setting " $\overline{CP} F_{nc}$ " is available only when the AD-8922A-04 is installed.

Class	Item	Parameter	Description		
$\overline{CP} F_{nc}$ Comparator	\overline{CP} Comparator mode	0	No comparison		
		1	Comparison, excluding "near zero" when the value is stable or overloaded		
		2	Comparison, including "near zero" when the value is stable or overloaded		
		3	Continuous comparison, excluding "near zero"		
		4	Continuous comparison, including "near zero"		
	5	Contact-outputs the second header information of the data received. (Applicable to AD-4212A, GP and GX-K)			
	bEP_{-} LO buzzer	0	OFF	Selects whether or not to sound the buzzer when LO.	
		1	ON		
		0	OFF		
	bEP_{-} OK buzzer	1	ON		
0		OFF	Selects whether or not to sound the buzzer when HI.		
bEP_{-} HI buzzer	1	ON			
	0	OFF			

▪ Factory setting

Note: “Near zero” indicates the amount of ten digits (Digit = the smallest displayable weighing value).

1 1 -3 Setting the Upper and Lower Limit Values

- Up to 10 set of upper and lower limit values can be stored.
- Using the stored upper and lower limit values, comparison can be performed easily. To recall the stored values, press and hold the **ON:OFF** key and press the **MODE** key.

1 1 -3 -1 Storing the upper and lower limit values

To store new upper and lower limit values, recall the stored data ("C01" to "C10") and change them.

1. While pressing and holding the **ON:OFF** key, press the **RE-ZERO** key to enter the confirmation mode. The upper limit value data (Comparator number and the upper limit mass (blinking)) of the comparator number that was selected last.

Displaying example

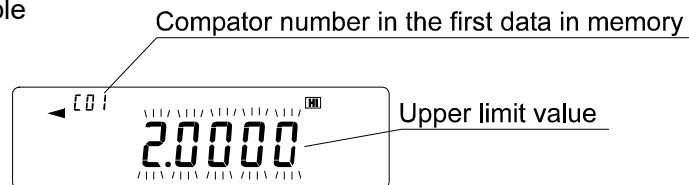

2. Select the comparator number using the following keys.

RE-ZERO key To increase the comparator number by 1.
MODE key To decrease the comparator number by 1.

Each time the key is pressed, the upper limit value and the lower limit value of the comparator number selected is displayed alternately. (C01 HI ⇔ C01 LO ⇔ C02 HI ⇔ C02 LO ⇔ ...)

3. Press the **SAMPLE** key to go to the storing mode to change the stored values.

Digital input mode

SAMPLE key To select the digit to change the value.

RE-ZERO key To change the value of the digit selected.

MODE key To move the decimal point position to the right by 1 digit.

ON:OFF key (press and hold) **MODE** key To switch the polarity.

PRINT key To store the new setting and return to step 2.

CAL key To cancel the new setting and return to step 2.

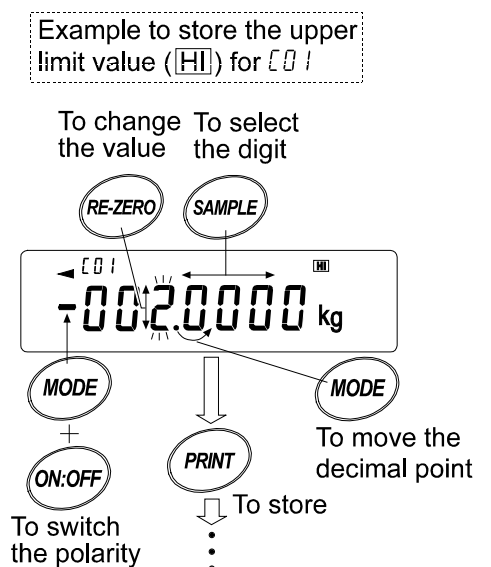

4. Press the **CAL** key to return to the weighing data display.

1 1-3-2 Recalling the upper and lower limit values

The procedure below describes an easy way to recall the upper and lower limit values to be used for weighing.

- 1 While pressing and holding the **ON:OFF** key, press the **MODE** key to enter the selection mode.
- 2 The upper limit value last selected with its comparator number appears.
3. Select the comparator number using the following keys.

RE-ZERO key To increase the comparator number by 1.
MODE key To decrease the comparator number by 1.

Each time the key is pressed, the upper limit value and the lower limit value of the comparator number selected is displayed alternately. (**001HI** ⇔ **001LO** ⇔ **002HI** ⇔ **002LO** ⇔...)
Only the stored comparator numbers are displayed.

- 4 Press the **PRINT** key to confirm the selection and return to the weighing data display with the selected upper and lower limit values ready for use (In the example shown below, the values of "**008**".)

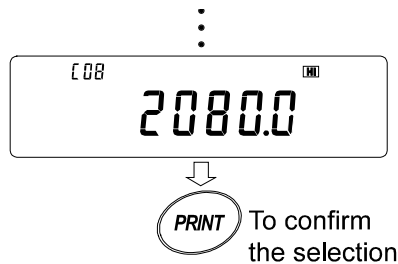

Note: When no operation is performed in step 4 (after a few seconds of inactivity), the AD-8922A selects the value currently displayed and returns to the weighing data display automatically.

To cancel the operation, press the **CAL** key.

1 2 CURRENT LOOP INPUT (AD-8922A-05)

Can receive the current loop output from the weighing instrument. The data received can be output to an external device such as a personal computer and a printer, using the RS-232C serial interface. The weighing instrument can not be operated using the AD-8922A keys.

Note: When AD-8922A-05 is installed, the pin assignment (DIN 8-pin) of the RS-232C serial interface, to connect an external device, will be changed.

Note: The AD-4212C does not have current loop output. Therefore, this option can not be used.

1 2 - 1 Current Loop Input Specifications

Accessories

Cable to connect to a weighing instrument (AX-KO1786-200: Length: Approx.2 m)

DIN 7-pin to D-Sub 9-pin

Instruction manual

1 copy

Note: When the AD-8922A-05 is installed, the communications cable provided with the AD-8922A as standard will not be used.

Panel view

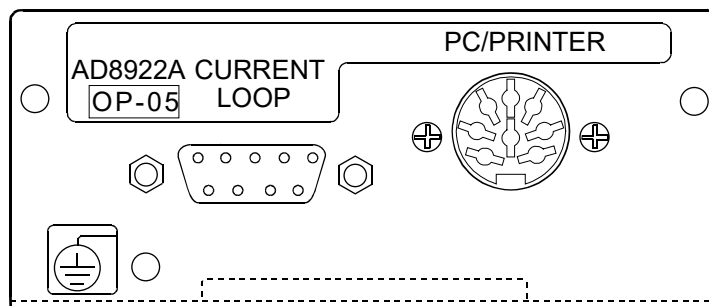

Current loop input / PC/PRINTER output

Transmission system	:	Input: 20 mA current loop (Active) D-Sub 9-pin (Current loop)
		Output: EIA RS-232C DIN 8-pin (PC/PRINTER)
Transmission form	:	Asynchronous, uni-directional
Data format	:	Baud rate : 600, 1200, 2400, 4800, 9600, 19200 bps
		Data bits : 7 bits or 8 bits
		Parity bit : EVEN, ODD (Data bits 7 bits)
		NONE (Data bits 8 bits)
		Stop bits : 1 bit or 2 bits
		Code : ASCII

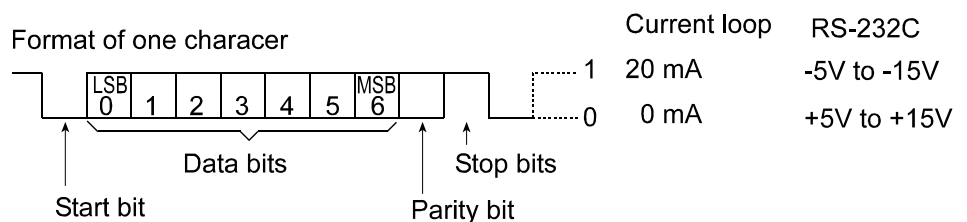

Note: When a baud rate of 4800 bps or higher is used, communication may not be performed properly.

Circuit

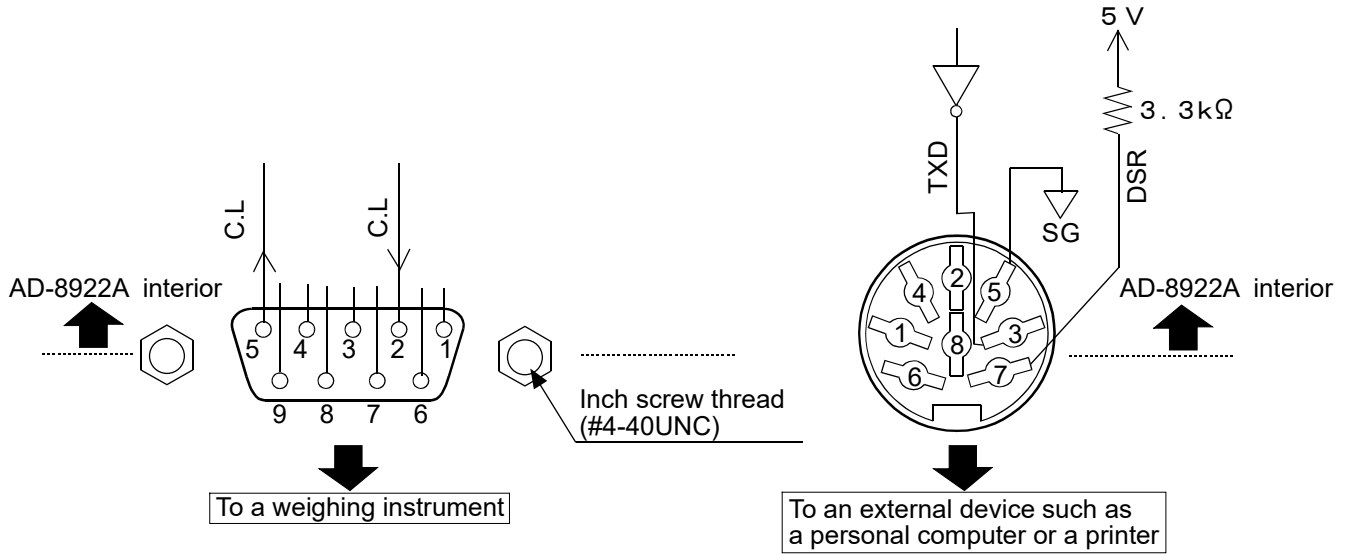

Connection to the weighing instrument

D-Sub 9-pin (Current loop)

Pin No.	Signal name	Description
1	—	N.C.
2	C.L	Current loop
3	—	N.C.
4	—	N.C.
5	C.L	Current loop
6	—	N.C.
7	—	N.C.
8	—	N.C.
9	—	N.C.

Connection to an external device

DIN 8-pin (PC/PRINTER)

Pin No.	Signal name	Description
1	—	N.C.
2	—	N.C.
3	TXD	Transmit data (RS-232C output)
4	—	N.C.
5	SG	Signal ground
6	—	N.C.
7	DSR	Data set ready (RS-232C output)
8	—	N.C.

1 3 ANALOG OUTPUT (AD-8922A-06)

Converts the specified digits of the weighing data received from the weighing instrument to voltage and outputs. The output voltage can be selected from "0 to 1 V" and "0.2 to 1 V".

Note: When the AD-8922A-06 is installed, the pin assignment (DIN 8-pin), of the RS-232C serial interface, to connect an external device, will be changed.

When connected to the AD-4212C, the both instruments can not be shared power.

1 3 - 1 Analog Output Specifications

Accessories

DIN connector (Plug)	1 pc.	
Screwdriver	1 pc.	
Instruction manual	1 copy	

Panel view

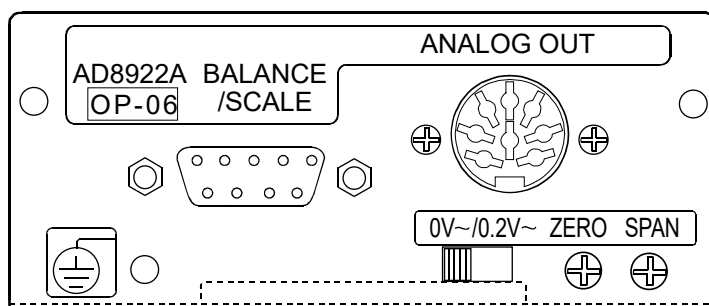

Analog output

Output impedance	100 Ω or less
Linearity	0.3% or less
Output range	0 V-1 V (With the slide switch set to "0V~") 0.2 V-1 V (With the slide switch set to "0.2V~")

RS-232C

Transmission system	: EIA RS-232C
Transmission form	: Asynchronous, bi-directional, half duplex
Data format	: Baud rate : 600, 1200, 2400, 4800, 9600, 19200 bps
	: Data bits : 7 bits or 8 bits
	: Parity bit : EVEN, ODD (Data bits 7 bits) NONE (Data bits 8 bits)
	: Stop bits : 1 bit or 2 bits
	: Code : ASCII
	: Terminator : <CR> or <CR><LF>

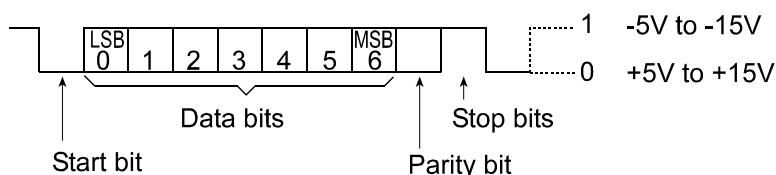

Circuit

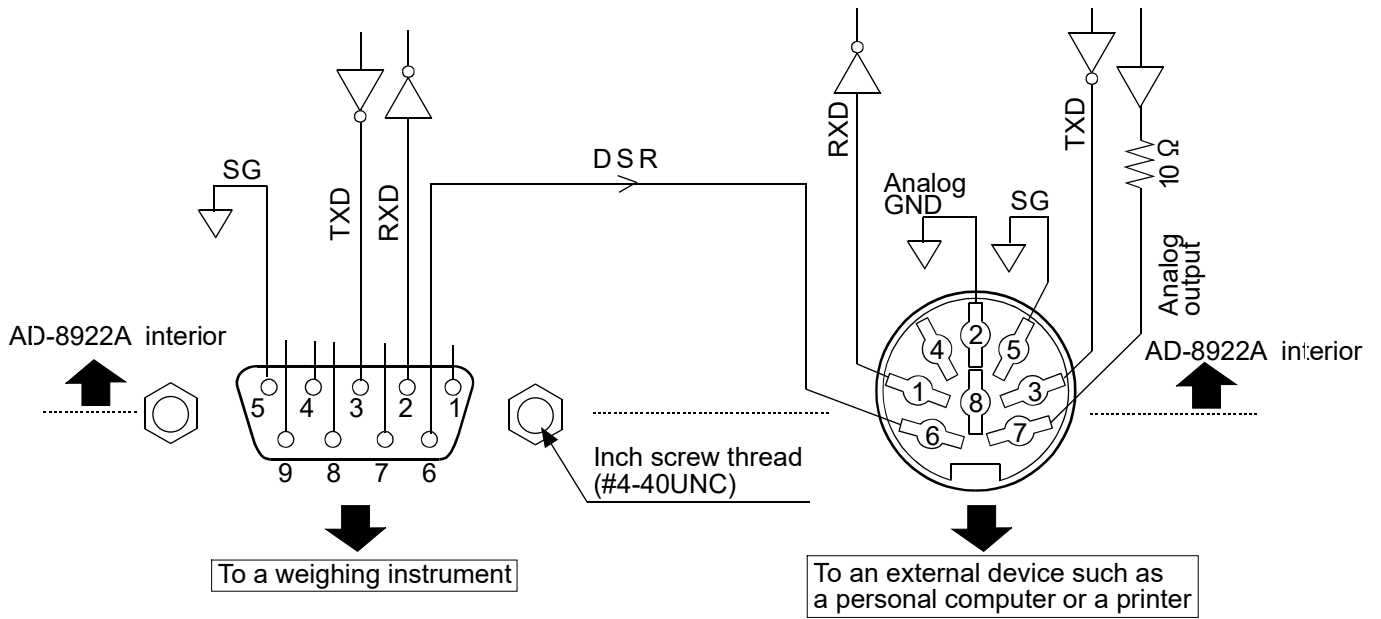

Connection to the weighing instrument

D-Sub 9-pin (BALANCE/SCALE)

Pin No.	Signal name	Direction	Description
1	—	—	N.C.
2	RXD	Input	Receive data
3	TXD	Output	Transmit data
4	—	—	N.C.
5	SG	—	Signal ground
6	DSR	Input	Data set ready
7	—	—	N.C.
8	—	—	N.C.
9	—	—	N.C.

(AD-8922A is a DTE. Connects to a DCE such as a weighing instrument using a straight through cable.)

Connection to an external device

DIN 8-pin (ANALOG.OUT)

Pin No.	Signal name	Direction	Description
1	—	—	N.C.
2	AG	—	Analog ground
3	TXD	Output	Transmit data
4	—	—	N.C.
5	SG	—	Signal ground
6	DSR	Output	Data set ready
7	AOUT	Output	Analog output
8	RXD	Input	Receive data

1 3 - 2 Function setting

The function setting " R_{out} " is available only when the AD-8922A-06 is installed.

Class	Item	Parameter	Description	
R_{out} Analog output	R_n Analog output mode	▪ 0	2-digit output	Converts the consecutive 2 digits, with the digit selected in SEL as the least, to voltage and outputs.
		1	3-digit output	Converts the consecutive 3 digits, with the digit selected in SEL as the least, to voltage and outputs.
	SEL Analog output digit selection	▪ 0	Selects the first digit as the least.	
		1	Selects the second digit as the least.	
		2	Selects the third digit as the least.	
		3	Selects the fourth digit as the least.	
		4	Selects the fifth digit as the least.	
		5	Selects the sixth digit as the least.	

▪ Factory setting

Setting example

When R_n 0 is set:

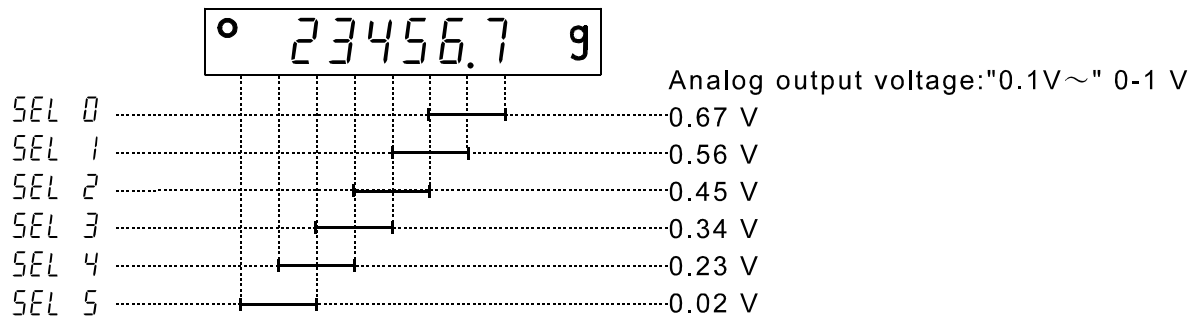

Notes

The invisible high-order digits are regarded as zero.

When R_n 1 is set:

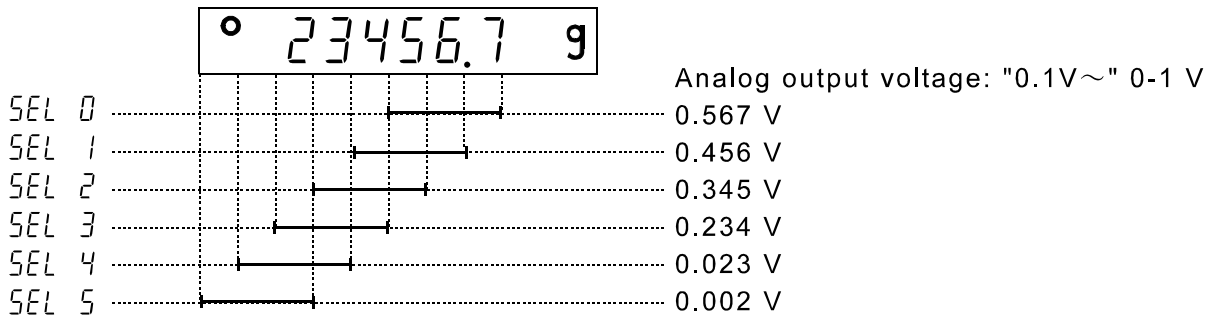

1 3 -3 Switching Output Voltage

The output voltage can be switched using the slide switch on the option panel. "0V~" has been set at factory before shipment.

"0V~" (0-1 V): At zero=0.000 V At full scale=1.000 V
 "0.2V~" (0.2-1 V): At zero =0.200 V At full scale=1.000 V

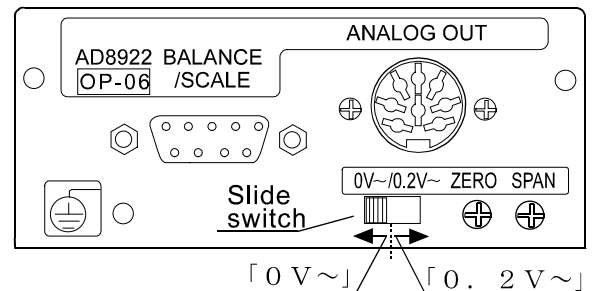

1 3 -4 Output Voltage Fine Adjustment

The output voltage has been adjusted at the factory before shipment.

Using the ZERO and SPAN fine-adjustment knobs and a voltmeter, output voltage can be fine adjusted.

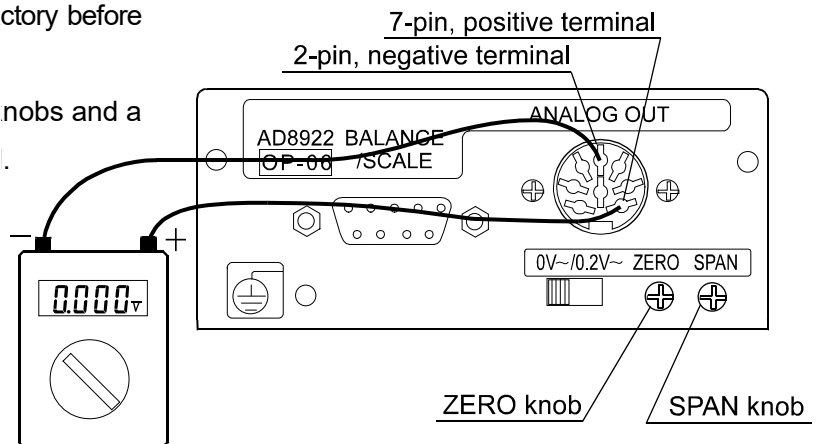

1 3 -4 -1 Fine-adjustment procedure

1. While pressing and holding the **ON:OFF** key, press the **RE-ZERO** key. At this time, the output voltage will be at zero.
2. Turn the ZERO knob so that the voltmeter indicates 0.000 V when the slide switch is set to "0V~"; 0.200 V when the slide switch is set to "0.2V~".
3. Press the **RE-ZERO** key. At this time, a voltage of 1 V is generated. Turn the SPAN knob so that the voltmeter indicates 1.000 V.
4. Press the **RE-ZERO** key again to return to step 2. Repeat steps 2 and 3 until the correct output voltage is obtained.
5. Press the **CAL** key to return to the weighing data display.

Display for setting the output to 0 V (0.2V)

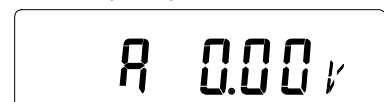

Display for setting the output to 1 V.

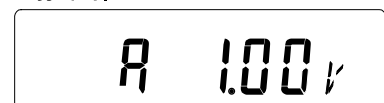

1 3-5 Fixed Output Voltage

The output voltage is fixed under the following conditions:

1. While the weighing data is not displayed (e.g., the bar display, function setting operation) :0 V (or 0.2 V)
2. When “-E” (Weighing pan error) is being displayed: :0 V (or 0.2 V)
3. When “E” (Overload error) is being displayed: :1V

1 4 ACCESSORIES (CABLE LIST)

1. Cable to connect the AD-8922A, AD-8922A-01, AD-8922A-04, or AD-8922A-06 and the weighing instrument

Table 8 Applicable weighing instruments and what is required

Weighing instrument	What is required to connect to a weighing instrument		
	Option for the instrument	Communications cable (Length 2 m)	
		· AD-8922A standard · To connect AD-8922A-04 or AD-8922A-06	To connect AD-8922A-01
AD-4212C/D	None (D-Sub 9-pin)	Cable provided for AD-4212C (10m) AX-KO3590-1000	AX-KO3705-500 (5m)
GX, GF, GX-K, GF-K, GP, AD-4212A/B, GR, MC	None (D-Sub 25-pin)	AX-KO1710-200	AX-KO577A-200
GX-A, GF-A, GX-M, GF-M, EK- <i>i</i> , EW- <i>i</i> , FC- <i>i</i> , FC-S <i>i</i> , GH, HR- <i>i</i> , FZ- <i>i</i> , FX- <i>i</i> , BM, HR-A/AZ	None (D-Sub 9-pin)	AX-KO2466-200	AX-KO1786-200
EJ, HV-C, HV-CP, HW-C, HW-CP	OP-03 (D-Sub 9-pin)	AX-KO2466-200	AX-KO1786-200
HV-G, HV-WP, HW-G, HW-WP	None (DIN 8-pin)	AX-KO1786-200	AX-KO507A-200
FG-L, FG-M	OP-23 (DIN 8-pin)	AX-KO1786-200	AX-KO507-W200

Note: A substitute communications cable may be provided as specified when ordering the AD-8922A or AD-8922A-01.

2. Cable to connect the AD-8922A-05 and the weighing instrument: AX-KO1786-200 (AD-8922A-05 accessory)
3. Cable to connect the AD-8922A or AD-8922A-05 and an external device

When connecting to a personal computer: AX-KO1786-200

When connecting to the compact printer AD-8127: AX-KO1786-200

