

REVISIONS							
ZONE	LTR.	DESCRIPTION	DATE	ECN	BY	CKD	APVD
-	C	REMOVED METRIC 30t CAPACITY	06/28/13	-	FR	AA	AA
-	D	REDRAWN FOR CATALOG CLARITY	03/30/15	2015-13	RLU	JSP	AA
-	E	REDRAWN FOR LABELING CONSISTENCY	01/25/16	2016-10	TB	AB	AA

PERFORMANCE SPECIFICATIONS:

- CAPACITIES: 30t (66K), 56K (LB).
- RATED OUTPUT: 2.00 mV/V \pm 0.25%.
- SAFE OVERLOAD: 150% FS.
- EXCITATION VOLTAGE: 10V AC/DC (15V MAX).
- INPUT RESISTANCE: 380 \pm 10 Ω .
- OUTPUT RESISTANCE: 350 \pm 5 Ω .
- ZERO BALANCE: \pm 1.00% FS.
- SEAL TYPE: HERMETICALLY SEALED IP67.
- NON-LINEARITY: \pm 0.03% FS.
- HYSTERESIS: \pm 0.02% FS.
- REPEATABILITY: \pm 0.01% FS.
- CREEP: \pm 0.02% FS (IN 30 MINUTES).
- NTEP RATED.
- CLASS III, 10,000 DIVISION, MULTIPLE CELL.
- COMPENSATED TEMPERATURE RANGE: 0°C - 30°C.
- TEMPERATURE EFFECT ON ZERO: \pm 0.0027% FS/°C.
- TEMPERATURE EFFECT ON OUTPUT: \pm 0.0015% FS/°C.
- INSULATION RESISTANCE: 5000 MEGOHMS.
- LOAD CELL CABLE: 4-22AWG, \varnothing 6.8MM, BRAIDED, 50FT.
- LOAD CELL WIRING:
 - GRN (+EXC)
 - BLK (-EXC)
 - WHT (+SIG)
 - RED (-SIG)
 - BRAID/YELLOW: SHIELD
- FM APPROVED.

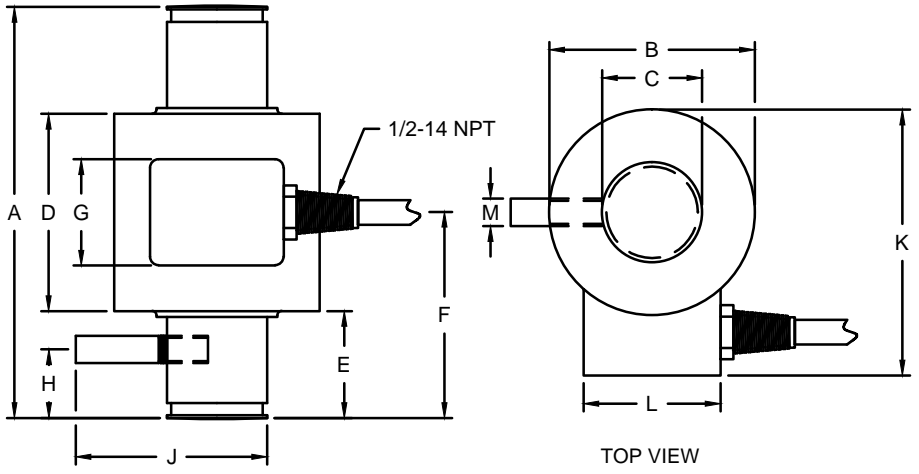
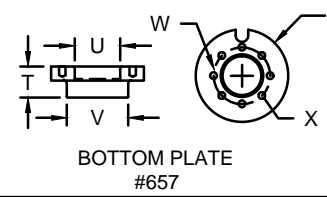
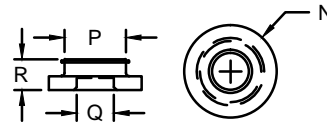
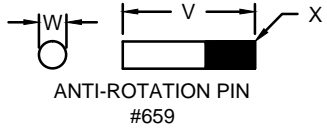

RATED CAPACITY	DIMENSION																					
	A	B	C	D	E	F	G	H	J	K	L	M	N	P	Q	R	S	T	U	V	W	X
30t	7.56	3.00	1.46	2.88	2.34	3.78	1.62	1.00	2.88	3.88	2.00	0.38		-	-	-	-	-	-	-	-	-
56K	7.56	3.00	1.46	2.88	2.34	3.78	1.62	1.00	2.88	3.88	2.00	0.38		-	-	-	-	-	-	-	-	-
656A	-	-	-	-	-	-	-	-	-	-	-	-	3.75	2.46	1.50	1.25	-	-	-	-	-	-
657	-	-	-	-	-	-	-	-	-	-	-	-	-	-	-	-	4.13	1.69	1.50	2.46	2.25	M10x1
659	-	-	-	-	-	-	-	-	-	-	-	-	-	-	-	-	-	-	-	1.89	0.38	M10x1

DO NOT ALTER WITHOUT AGENCY NOTIFICATION

COTI GLOBAL SENSORS, INC.

CG-26S2 COMPRESSION CANISTER NTEP LOAD CELL

THIS DRAWING USES THIRD ANGLE PROJECTION

THIS DOCUMENT CONTAINS PROPRIETARY INFORMATION AND SUCH INFORMATION MAY NOT BE REPRODUCED OR DISCLOSED FOR ANY PURPOSE OR USED TO PRODUCE THE ARTICLE OR SUBJECT WITHOUT WRITTEN PERMISSION FROM COTI GLOBAL SENSORS, INC.

TOLERANCES UNLESS OTHERWISE SPECIFIED
 .XX = \pm 0.02"
 .XXX = \pm 0.005"
 .XXXX = \pm 0.0002"
 FRACTIONS: \pm 1/16"
 ANGLES DEG. \pm 18

APPROVALS		DATE
DRAWN:	RLU	03/30/15
CHECKED:	AA	03/30/15
ENGINEER:	JSP	03/30/15
APPROVED:	AA	03/30/15
MATERIAL:	STAINLESS STEEL	
FINISH:	PASSIVATED	

SCALE	SIZE	PART/DRAWING NO.	REV.
NONE	B	DOD-CG-26S2	E
MODEL CG-26S2			SHEET 1 OF 1