

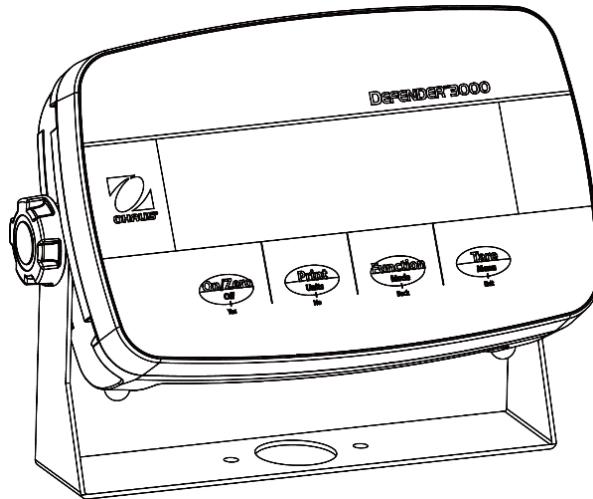

Defender™ 3000 Indicators Instruction Manual

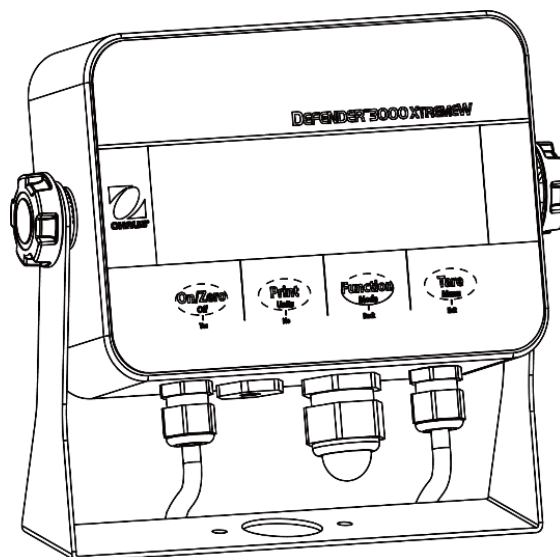

i-DT33P



i-DT33XW

Table of Contents

1.	INTRODUCTION	3
1.1.	SAFETY PRECAUTIONS	3
1.2.	INTENDED USE	3
1.3.	OVERVIEW OF PARTS AND CONTROLS	4
1.4.	MAINBOARD	5
1.5.	CONTROL FUNCTIONS	6
2.	INSTALLATION	8
2.1	UNPACKING	8
2.2	EXTERNAL CONNECTIONS.....	8
2.2.1	<i>Battery Power Supply</i>	8
2.2.2	<i>AC Power Supply</i>	8
2.3	INTERNAL CONNECTIONS	9
2.3.1	<i>Open the Housing</i>	9
2.3.2	<i>EasyConnect™ Indicator</i>	13
2.3.3	<i>Non-EasyConnect™ Indicator</i>	13
2.3.4	<i>i-DT33P RS232 Connection</i>	17
2.3.5	<i>i-DT33XW RS232 Connection</i>	17
2.4	MOUNTING BRACKET.....	18
3.	OPERATION	19
3.1	TURNING THE SCALE ON/OFF.....	19
3.2	WEIGHING MODE	19
3.2.1	<i>Enter the Mode and Start Weighing</i>	19
3.2.2	<i>Application Settings</i>	19
3.3	COUNTING MODE	20
3.3.1	<i>Enter the Mode</i>	20
3.3.2	<i>Start Counting</i>	20
3.3.3	<i>Application Settings</i>	20
3.4	CHECK	21
3.4.1	<i>Set Check Limits</i>	21
3.4.2	<i>Positive Check</i>	21
3.4.3	<i>Negative Check</i>	21
3.4.4	<i>Zero Check</i>	21
3.4.5	<i>Application Settings</i>	21
3.5	TOTALIZATION	23
3.5.1	<i>Application Settings</i>	23
3.5.2	<i>Enter the Mode</i>	23
3.5.3	<i>Totalization Method</i>	23
3.5.4	<i>View Totalization Result</i>	23
3.5.5	<i>Totalization Rules</i>	24
3.5.6	<i>Print Totalization Result and Format</i>	24
3.5.7	<i>Application Settings</i>	25
4.	MENU SETTINGS	26
4.1	MENU NAVIGATION	26
4.1.1	<i>User Menu (in segments)</i>	26
4.1.2	<i>Button Navigation</i>	27
4.2	CALIBRATION MENU.....	28
4.2.1	<i>Initial Calibration</i>	28
4.2.2	<i>Zero Calibration [ZFL]</i>	28
4.2.3	<i>Span Calibration [SPAN]</i>	28
4.2.4	<i>Linearity Calibration [L #]</i>	29
4.2.5	<i>GEO Code Adjustment [GEO]</i>	29
4.2.6	<i>Calibration Test [L.E5t]</i>	30
4.2.7	<i>End Cal [End]</i>	30
4.3	SETUP MENU	31
4.4	READOUT MENU	33
4.5	UNIT MENU.....	35
4.6	COMMUNICATION	35

4.6.1	RS232 Menu	35
4.6.2	Print Menu	37
4.6.3	USB Configuration	39
4.6.4	Ethernet Configuration.....	39
4.7	LOCK BUTTON CONFIGURATION	40
5.	LEGAL FOR TRADE.....	41
5.1	SETTINGS.....	41
5.2	VERIFICATION.....	41
5.3	SEALING	42
6.	MAINTENANCE	44
6.1	CLEANING.....	44
6.2	TROUBLESHOOTING	45
6.3	SERVICE INFORMATION	45
7.	TECHNICAL DATA.....	46
7.1	SPECIFICATIONS	46
7.2	TABLE OF GEO CODE VALUES	48
8.	COMPLIANCE.....	49
9.	APPENDICES	51
9.1	APPENDIX A.....	51
9.2	APPENDIX B.....	53
9.3	APPENDIX C.....	54
9.4	APPENDIX D.....	55
	LIMITED WARRANTY.....	56

1. INTRODUCTION

This manual contains installation, operation and maintenance instructions for i-DT33P and i-DT33XW indicators. Please read it completely before installation and operation.

1.1. Safety Precautions

Definition of Signal Warnings and Symbols

Safety notes are marked with signal words and warning symbols. These show safety issues and warnings. Ignoring the safety notes may lead to personal injury, damage to the instrument, malfunctions and false results.

WARNING	For a hazardous situation with medium risk, possibly resulting in severe injuries or death if not avoided.
CAUTION	For a hazardous situation with low risk, resulting in damage to the device or the property or in loss of data, or minor or medium injuries if not avoided.
ATTENTION	For important information about the product. May lead to equipment damage if not avoided.
NOTE	For useful information about the product.

Warning Symbols



General hazard



Explosion hazard



Electrical shock hazard

Safety Precautions



CAUTION: Read all safety warnings before installing, making connections, or servicing this equipment. Failure to comply with these warnings could result in personal injury and/or property damage. Retain all instructions for future reference.

- Before connecting power, verify that the equipment's input voltage range and plug type are compatible with the local AC mains power supply.
- Do not position the equipment such that it is difficult to reach the power connection.
- Only connect the power cord to a compatible grounded electrical outlet.
- Only use a power cord with a rating that exceeds the specifications on the equipment label. (Only for i-DT33P)
- Make sure that the power cord does not pose a potential obstacle or tripping hazard.
- Operate the equipment only under ambient conditions specified in these instructions.
- The equipment is for indoor use only.
- Do not operate the equipment in hazardous or unstable environments.
- Do not allow liquids to enter the equipment.
- Use only approved accessories and peripherals.
- Disconnect the equipment from the power supply when cleaning.
- Service should only be performed by authorized personnel.



WARNING: Never work in an environment subject to explosion hazards! The housing of the instrument is not gas tight. (Explosion hazard due to spark formation, corrosion caused by the ingress of gases).



WARNING: Electrical shock hazards exist within the housing. The housing should only be opened by authorized and qualified personnel. Remove all power connections to the unit before opening.

1.2. Intended Use

This instrument is intended for use in laboratories, pharmacies, schools, businesses and light industry. It must only be used for measuring the parameters described in these operating instructions. Any other type of use and operation beyond the limits of technical specifications, without written consent from OHAUS, is considered as not intended. This instrument complies with current industry standards and the recognized safety regulations; however, it can constitute a hazard in use. If the instrument is not used according to these operating instructions, the intended protection provided by the instrument may be impaired.

1.3. Overview of Parts and Controls

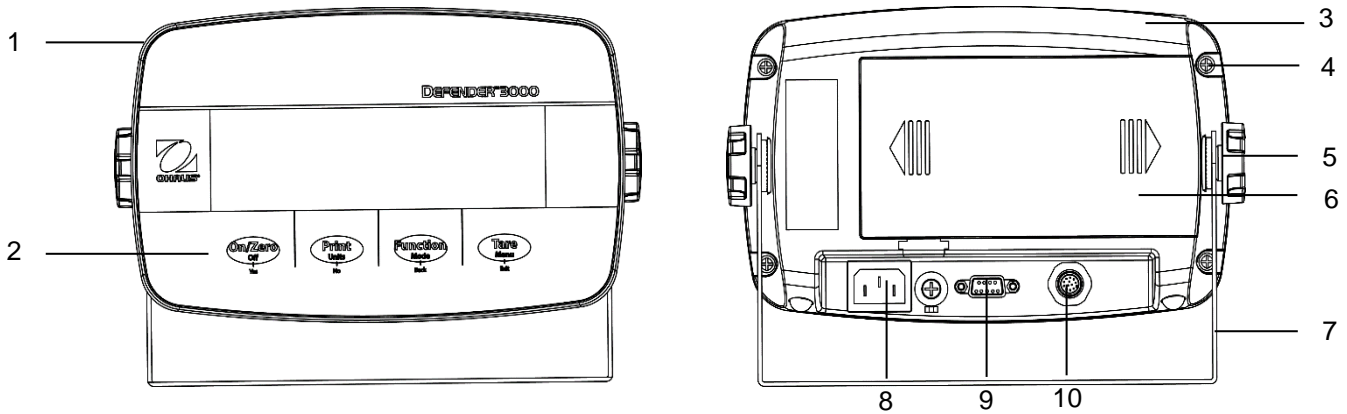

Figure 1-1 i-DT33P Indicator

Item	Description	Item	Description
1	Front Housing	6	Battery Cover
2	Control Panel	7	Mounting Bracket
3	Rear Housing	8	Power Cord Connector
4	Screws (5)	9	RS232 Connector
5	Adjusting Knobs (2)	10	Load Cell Connector

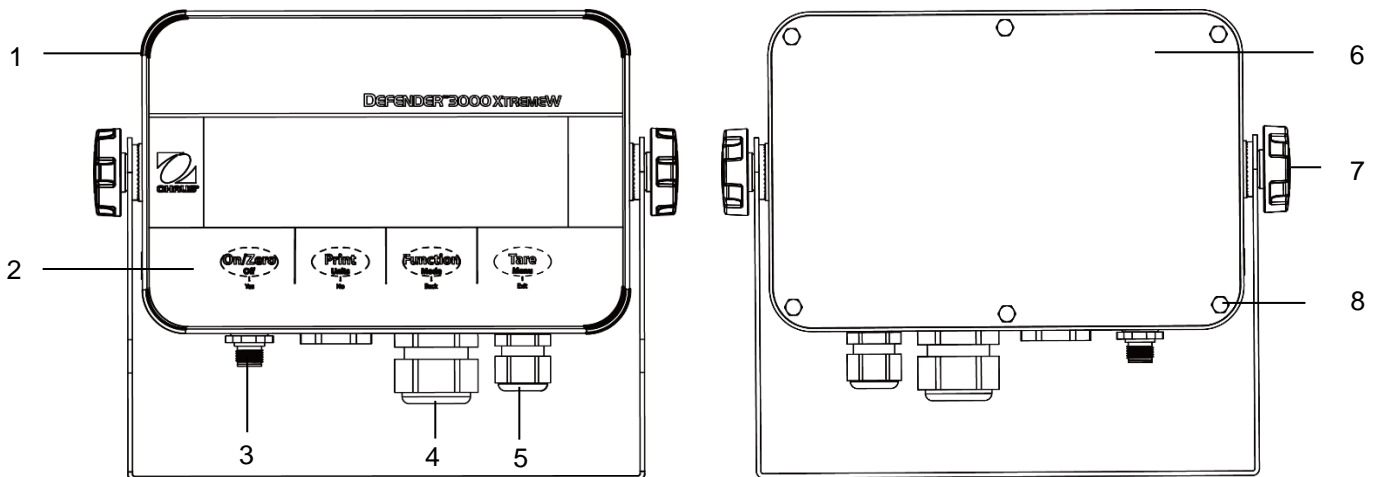

Figure 1-2 i-DT33XW Indicator

Item	Description
1	Front Housing
2	Control Panel
3	Load Cell Connector
4	Strain Relief for Option
5	Strain Relief for Power Cord
6	Rear Housing
7	Adjusting Knobs (2)
8	Hex Head Bolts (6)

Note:

- There are two types of load cell connector, one supports EasyConnect™ and one does not. Therefore the load cell connector varies for different models.
- For some i-DT33XW models, the position of load cell connector, strain relief for option and power cord may change. Please refer to the actual product.

1.4. Mainboard

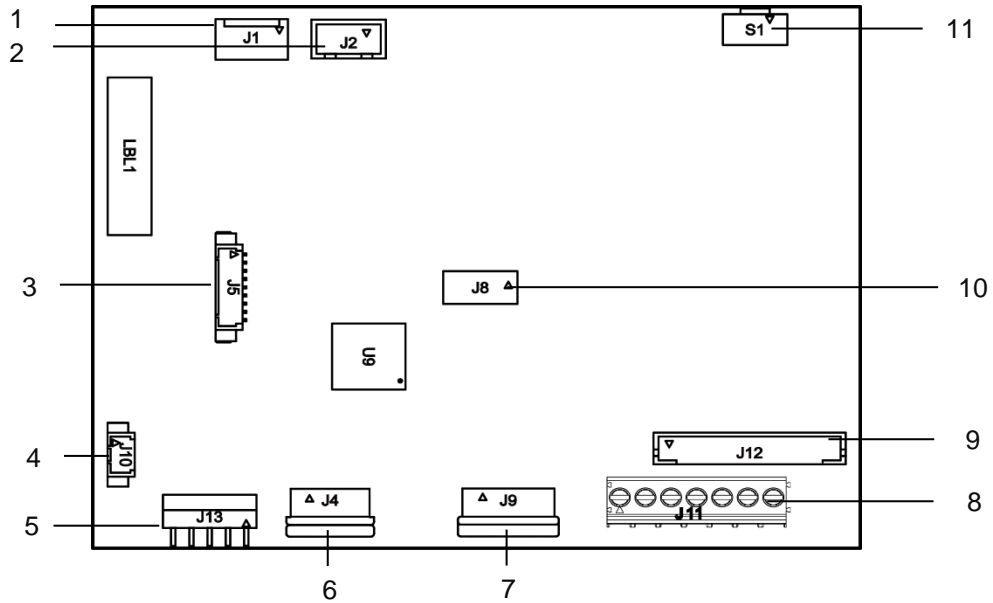

Figure 1-3 i-DT33P Mainboard

Item	Description	Item	Description
1	DC input (J1)	7	Display board connector (J9)
2	Dry cell input (J2)	8	Load cell terminal block (J11) (for models not supporting EasyConnect™)
3	Ethernet kit / USB device kit connector (J5)	9	Load cell connector (J12) (for models supporting EasyConnect™)
4	Backlight connector (J10)	10	Lead-acid battery charge board kit connector (J8)
5	RS232 connector (J13)	11	Security switch connector (S1)
6	Keyboard connector (J4)		

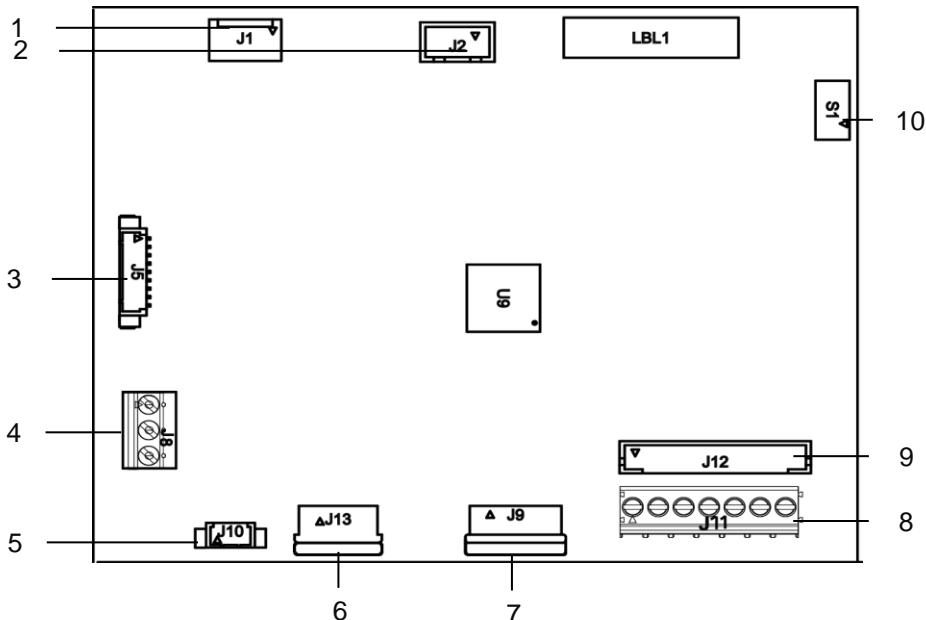

Figure 1-4 i-DT33XW Mainboard

Item	Description	Item	Description
1	DC input (J1)	6	Keyboard connector (J13)
2	Lead-acid battery input (J2)	7	Display board connector (J9)
3	Ethernet kit / USB device kit connector (J5)	8	Load cell terminal block (J11) (for models not supporting EasyConnect™)
4	RS232 connector (J8)	9	Load cell connector (J12) (for models supporting EasyConnect™)
5	Backlight connector (J10)	10	Security switch connector (S1)

Note: Mainboard may vary slightly for different regions.

1.5. Control Functions

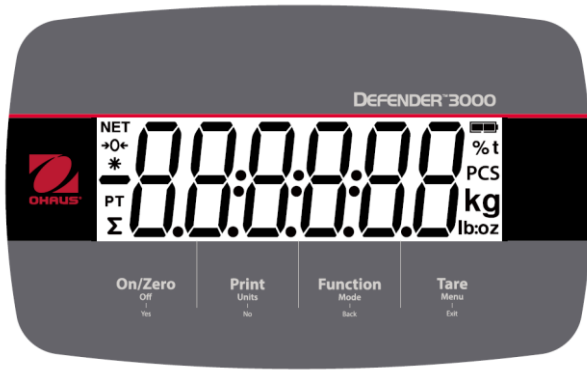

Figure 1-5 i-DT33P Control Panel

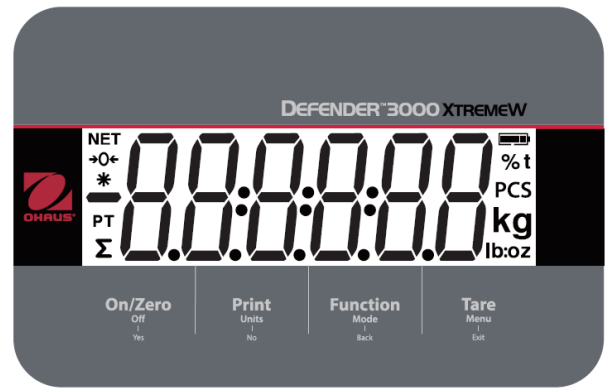

Figure 1-6 i-DT33XW Control Panel

Button	On/Zero Off Yes	Print Units No	Function Mode Back	Tare Menu Exit
Primary Function (Short Press)	On/Zero If the terminal is off, press to power on; If the terminal is on, press to set the zero point.	Print Sends the current value to the RS232 port if the Print Setup → Assignment → Demand menu is enabled.	Function Initiates an application mode.	Tare Performs a tare operation.
Secondary Function (Long Press)	Off If the terminal is on, press to power off.	Units Changes the weighing unit.	Mode Changes the application mode.	Menu Enters the user menu. Shows a tare value in application modes.
Menu Function (Short Press)	Yes Accepts the current setting on the display or selects a sub-menu or menu item.	No Advances to the next menu or menu item. Rejects the current setting on the display and advances to the next available one.	Back Moves back to the previous menu item.	Exit Exits the user menu. Aborts a calibration in progress. Exits when displaying totalization result or under and over value in check mode.

Notes:

- Short Press: press less than 1 second.
- Long Press: press and hold for more than 3 seconds.

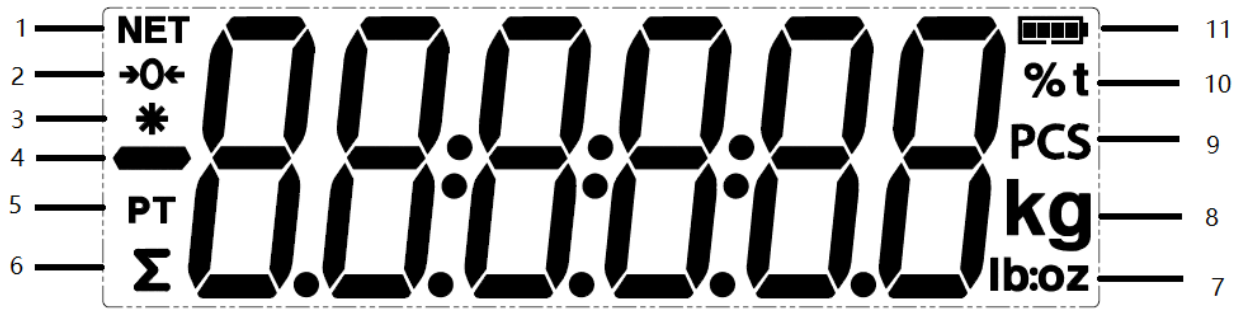

Figure 1-7 Display

Item	Description	Item	Description
1	NET symbol	7	Pound, Ounce, Pound:Ounce symbols
2	Center of Zero symbol	8	Kilogram, Gram symbols
3	Stable weight symbol	9	Pieces symbol
4	Negative symbol	10	Percent symbol, Tonne symbol
5	Preset tare symbol	11	Battery symbol
6	Totalization symbol		

2. INSTALLATION

2.1 Unpacking

Unpack the following items:

- i-DT33P or i-DT33XW indicator
- Rechargeable battery (i-DT33XW)
- Rechargeable battery (supplied in some regions for i-DT33P)
- Mounting bracket
- Knobs (2)
- Quick installation guide
- Instruction manual
- Two jumper wires supplied for connecting a 4-wire load cell cable.
- One ferrite core (supplied with some models for connecting load cell connector)

2.2 External Connections

2.2.1 Battery Power Supply

i-DT33P

Use 6 C size dry batteries (not included).

In some regions, the i-DT33P model comes with one lead-acid battery installed by factory.

Note: You can contact an authorized OHAUS dealer to buy the lead-acid battery as an option.

i-DT33XW

This model comes with one lead-acid battery installed by factory default.

Note: The lead-acid battery will charge automatically while connecting to the power supply. When charging, the battery level indicator increases or decreases in one grid, two grids, three grids and four grids. The battery level indicator will disappear when the battery is fully charged.

While operating on battery, the battery symbol indicates the battery status:



Battery 5%~25% remaining



Battery 25%~50% remaining



Battery 50%~75% remaining



Battery 75%~100% remaining



Attention: Before using the indicator for the first time, the internal rechargeable battery should be fully charged for up to 12 hours. The indicator can be operated during the charging process. The battery is protected against overcharging and the indicator can remain connected to the AC power line.



CAUTION: BATTERY IS TO BE REPLACED ONLY BY AN AUTHORIZED OHAUS SERVICE DEALER. RISK OF EXPLOSION CAN OCCUR IF THE RECHARGEABLE BATTERY IS REPLACED WITH THE WRONG TYPE OR IF IT IS NOT PROPERLY CONNECTED. DISPOSE OF THE RECHARGEABLE BATTERY ACCORDING TO LOCAL LAWS AND REGULATIONS.



Dispose of the lead acid battery according to local laws and regulations.

2.2.2 AC Power Supply

Connect the AC plug to an electrical outlet to power on the indicator. Connect the other end to the indicator if not connected.

2.3 Internal Connections

Some internal connections require to open the housing first. Therefore, please check the **Open the Housing** section below before making connections.



CAUTION: ELECTRICAL SHOCK HAZARD. REMOVE ALL POWER CONNECTIONS TO THE INDICATOR BEFORE SERVICING OR MAKING INTERNAL CONNECTIONS. THE HOUSING SHOULD ONLY BE OPENED BY AUTHORIZED AND QUALIFIED PERSONNEL, SUCH AS AN ELECTRICAL TECHNICIAN.

2.3.1 Open the Housing

2.3.1.1 i-DT33P

1. Turn the two knobs (circled) on each side of the indicator to disassemble the bracket.

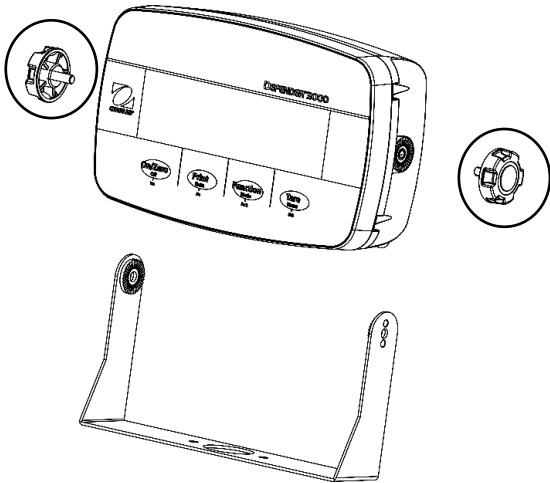

2. Remove the five screws (circled) from the rear housing.

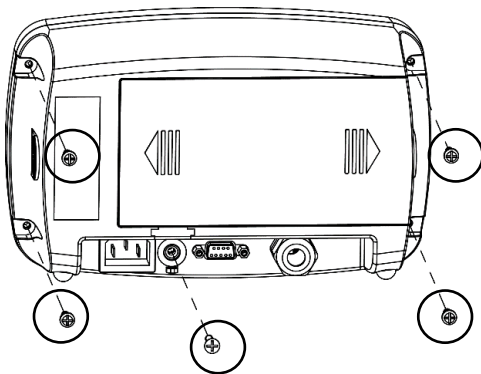

3. Open the rear housing.

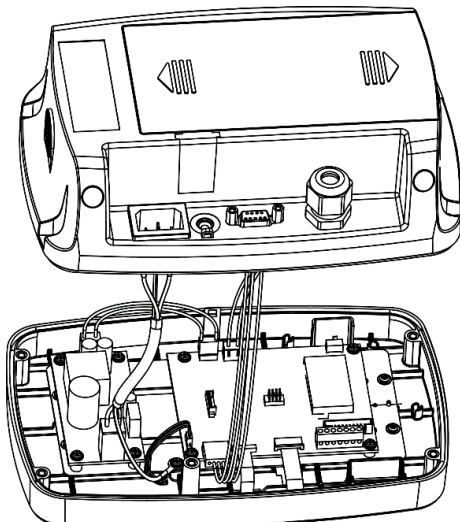

4. Close the housing and retighten the screws after finishing internal connections

Note: The screws should be tightened to 1 N•m (8-9 in-lb) torque.

2.3.1.2 i-DT33P (with Lead-acid Battery)

i-DT33P comes with a lead-acid battery installed in some regions. Please follow the instruction below for opening the housing and take out the battery.

Note: If your indicator does not contain the lead-acid battery but you want to purchase it as an accessory, you can contact an authorized OHAUS dealer to obtain it.

1. Remove the battery cover in the direction of the arrow.

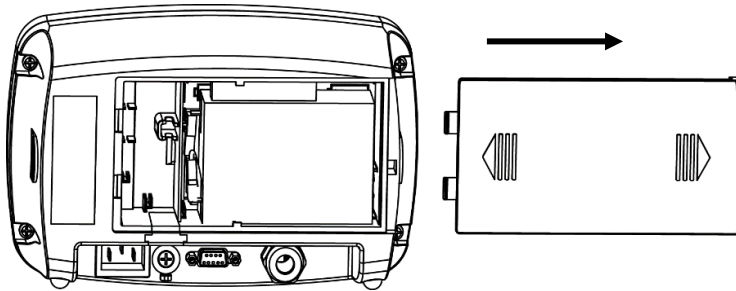

2. Take out the lead-acid battery (circled).

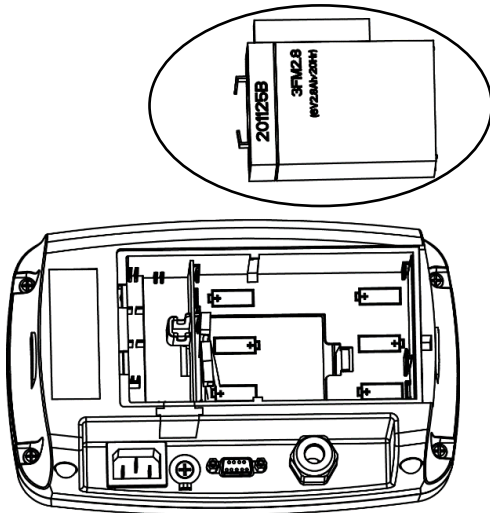

3. Slightly push the end of the charging cover (circled) in the direction of the arrow and take it out.

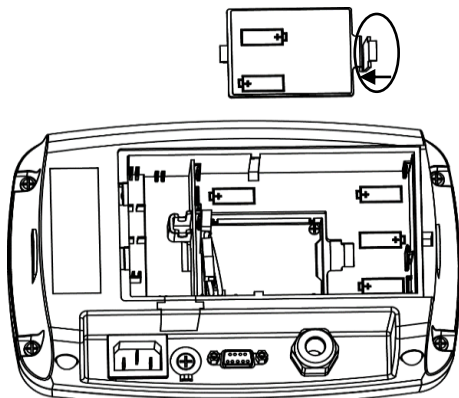

- Remove the two screws on the charging board (circled) and take it out.

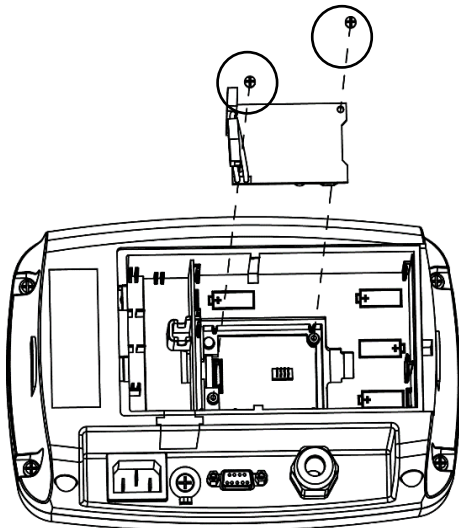

- Remove the five screws (circled) from the rear housing.

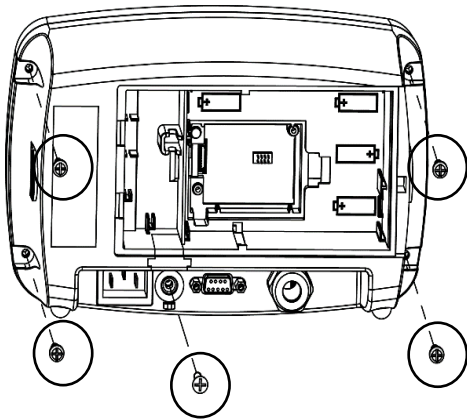

- Open the rear housing.

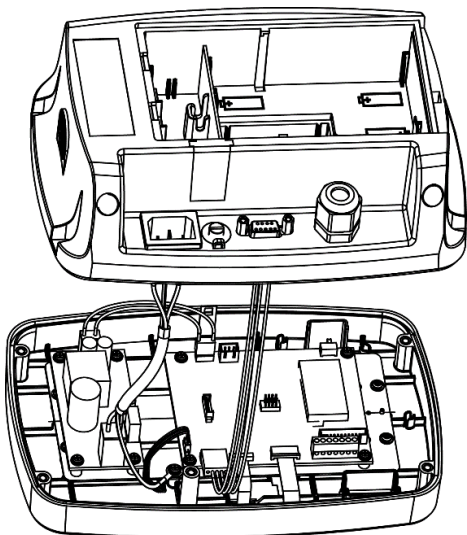

- Close the rear housing, retighten the screws and re-install the lead-acid battery after finishing internal connections

Note: The screws should be tightened to 1 N•m (8-9 in-lb) torque.

2.3.1.3 i-DT33XW

1. Turn the two knobs (circled) on each side of the indicator to disassemble the bracket.

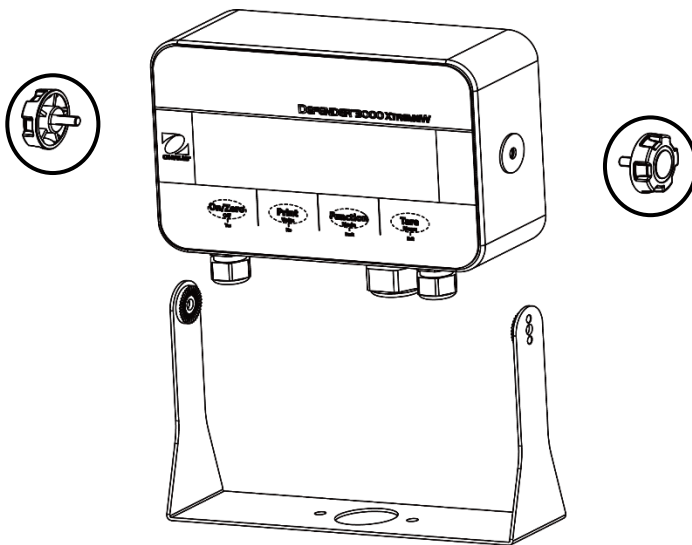

2. Remove the six hex head bolts from the rear housing of the indicator.

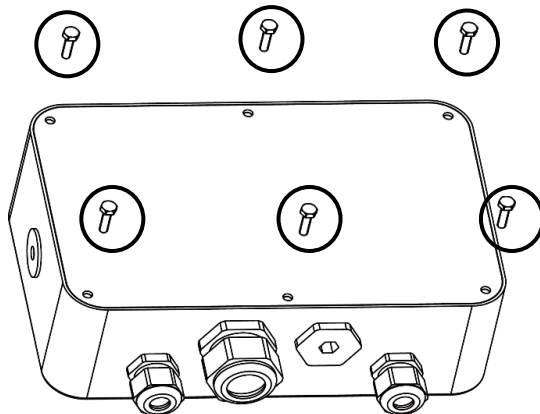

3. Open the rear housing.

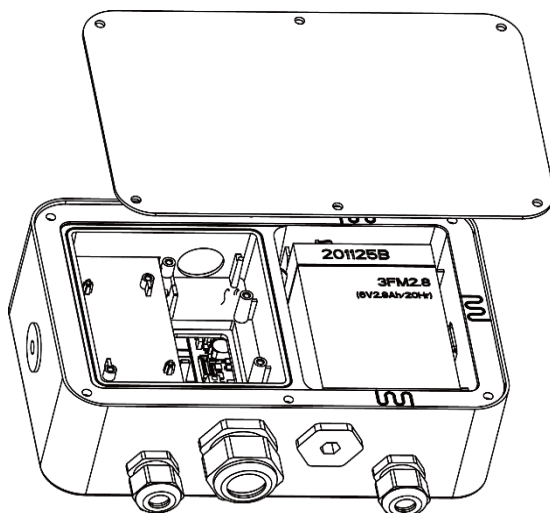

4. Close the housing and re-install the bolts after finishing internal connections

Note: The bolts should be tightened to 2.5 N•m (20-25 in-lb) torque to ensure a watertight seal.

2.3.2 EasyConnect™ Indicator

To connect an OHAUS EasyConnect™ scale base to an i-DT33P or an i-DT33XW EasyConnect™ indicator, plug the base's connector into the external load cell connector located at the back (i-DT33P) or bottom (i-DT33XW) of the indicator. Then rotate the base connector's locking ring in the direction of the arrows demonstrated below.

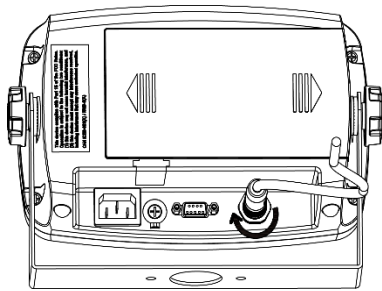

Figure 2-1 i-DT33P

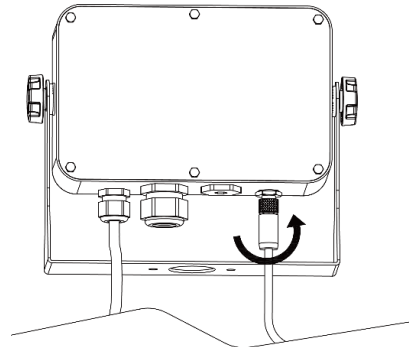

Figure 2-2 i-DT33XW

Note: For connecting bases which do not support EasyConnect™ to an EasyConnect™ indicator, contact an authorized OHAUS dealer to obtain a load cell cable gland kit (P/N 30379716) as an accessory.

2.3.3 Non-EasyConnect™ Indicator

To connect a non-EasyConnect™ scale base to an i-DT33P or an i-DT33XW non-EasyConnect™ indicator, follow the instruction in **Open the Housing** section to open the housing first before proceeding.

Note: For connecting EasyConnect™ bases to a non-EasyConnect™ indicator, contact an authorized OHAUS dealer to obtain a load cell cable gland kit (P/N 30427858) as an accessory.

2.3.3.1 i-DT33P

1. After opening the housing, release the load cell connector (circled) on the rear of the indicator and then pass the load cell cable through it.

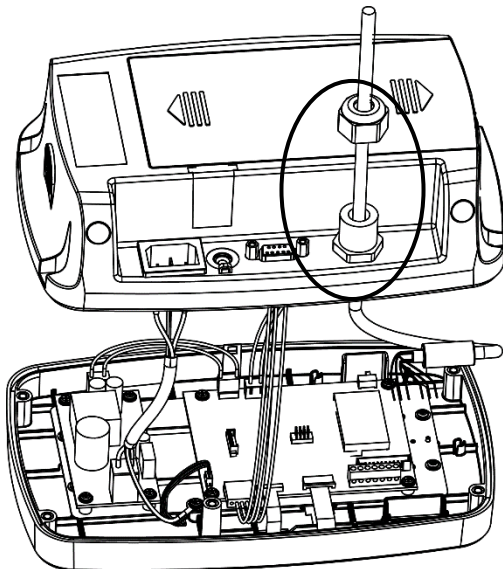

2. Connect all the cables on the load cell cable to the load cell terminal block on the mainboard (circled). Please refer to the **Load Cell Terminal Block** section for details of the connections.

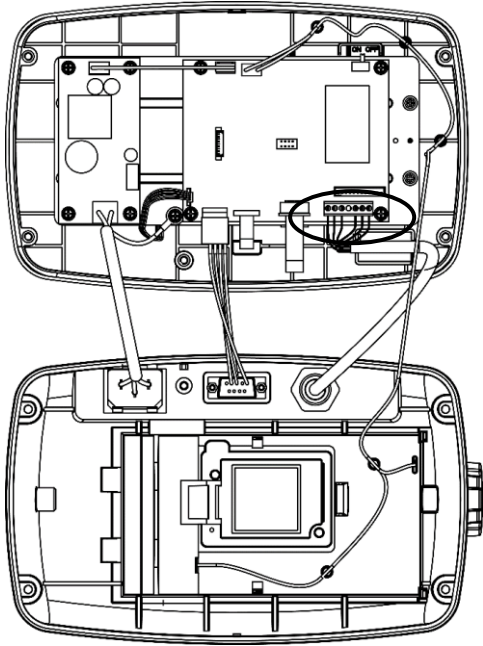

2.3.3.2 i-DT33XW

1. After opening the housing, unplug the battery connectors (circled) and take out the battery.

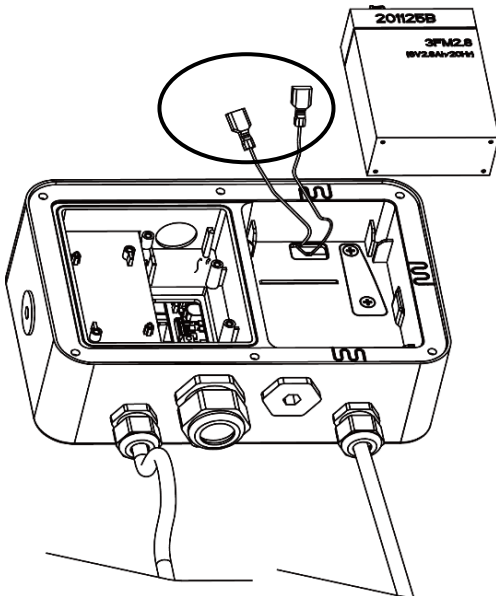

2. Unscrew the two screws on the sealing cover (circled), take out the cover, and then take out the first layer of the built-in housing.

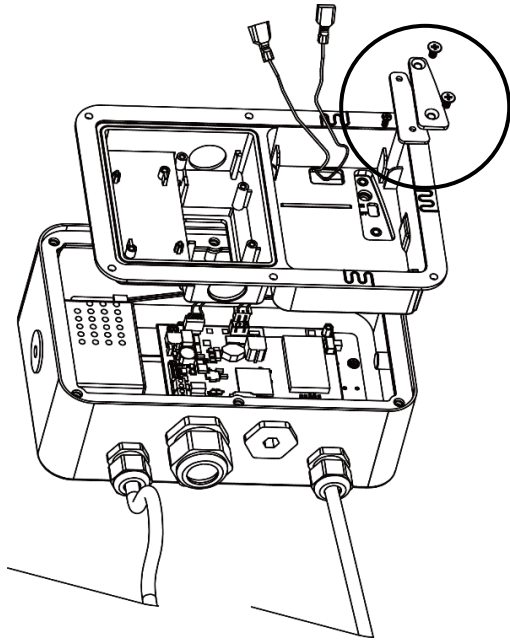

3. Release the load cell connector (circled) on the bottom of the indicator and then pass the load cell cable through it.

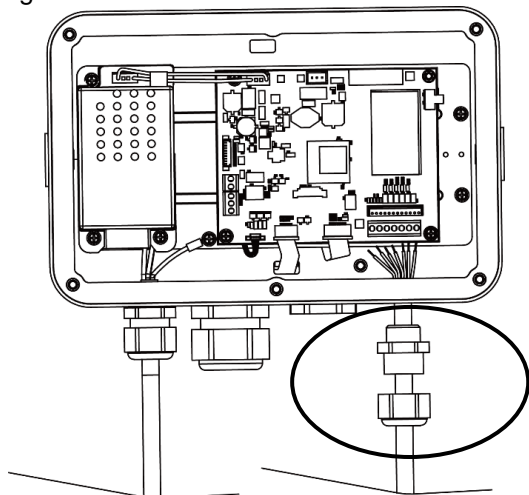

4. Connect all the cables on the load cell cable to the load cell terminal block on the mainboard (circled). Please refer to the **Load Cell Terminal Block** section for details of the connections.

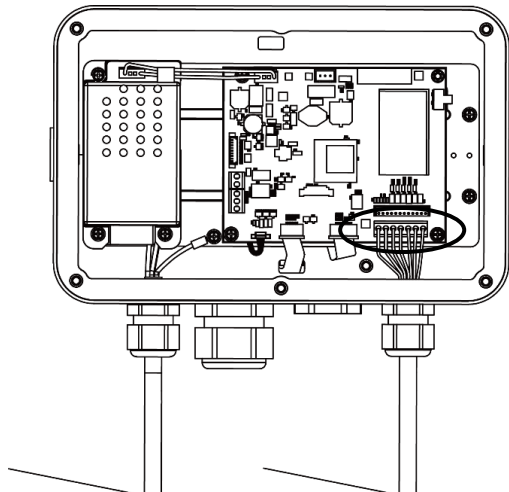

2.3.3.3 Load Cell Terminal Block

Proceed with the previous section, to connect the load cell terminal block, first locate it on the mainboard following the instruction in the previous two sections for the two models.

After finding the load cell terminal block, check table 2-1 for the definition of each terminal screw connection and make connections based on it. Please note that when using four-wire load cells, jumpers (the two short wires supplied) must be placed between the +Excitation (+EXE) and +Sense (+SEN) terminals and between the -Excitation (-EXE) and -Sense (-SEN) terminals.

The i-DT33P and i-DT33XW indicators are designed to support both 2mV/V and 3mV/V load cells from the same circuitry. A load cell output rating selection jumper is not required.

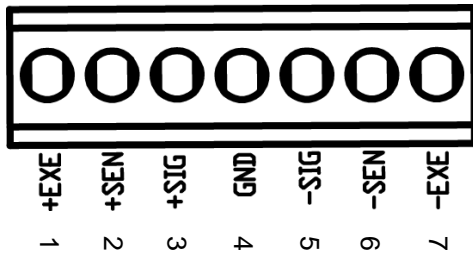

Figure 2-3 load Cell Terminal Block

Table 2-1 Jumper Connections

Number	Connection
1	+EXE
2	+SEN
3	+SIG
4	GND
5	-SIG
6	-SEN
7	-EXE

2.3.3.4 Installing the Ferrite Core

In order to meet certain electrical noise emission limits and to protect i-DT33P and i-DT33XW from external influences, it is necessary to install a ferrite core on the load cell cable connected to the indicator. The ferrite core is supplied.

To install it, simply route the cable through the center of the core. Either the complete cable or the individual wires can be wrapped through it.



Figure 2-4 Ferrite Core

2.3.4 i-DT33P RS232 Connection

Connect the optional RS232 cable to the RS232 connector on the rear housing of the i-DT33P indicator. Please refer to table 2-2 for the definition of each pin if needed.

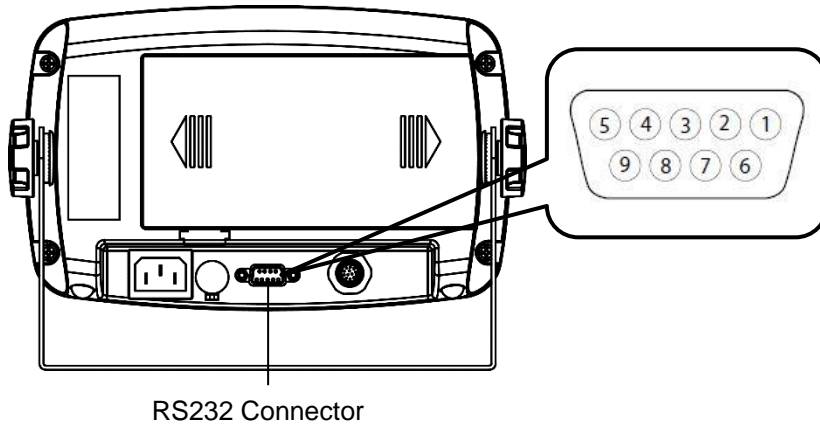

Table 2-2 RS232 Pins

Pin	Connection
1	N/C
2	TXD
3	RXD
4	N/C
5	GND
6	N/C
7	N/C
8	N/C
9	N/C

Figure 2-5 i-DT33P RS232 Connector

2.3.5 i-DT33XW RS232 Connection

For i-DT33XW model, to make the RS232 connection:

1. Open the rear housing. Please refer to **Open the Housing** section for how to open the rear housing.
2. Take out the battery. Please refer to the **i-DT33XW** sub-section of **Non-EasyConnect™ Indicator** section for how to take out the battery.
3. Release the strain relief for option connector on the bottom of the indicator and remove the plug on it.
4. Pass the optional RS232 cable through the connector and attach it to the RS232 terminal block on the mainboard.
5. Attach the watertight seal to the cable and push it into the strain relief for option connector. Tighten the strain relief for option connector with the watertight seal in it to finish installation.

Note: Please check the graphic below for the parts mentioned above.

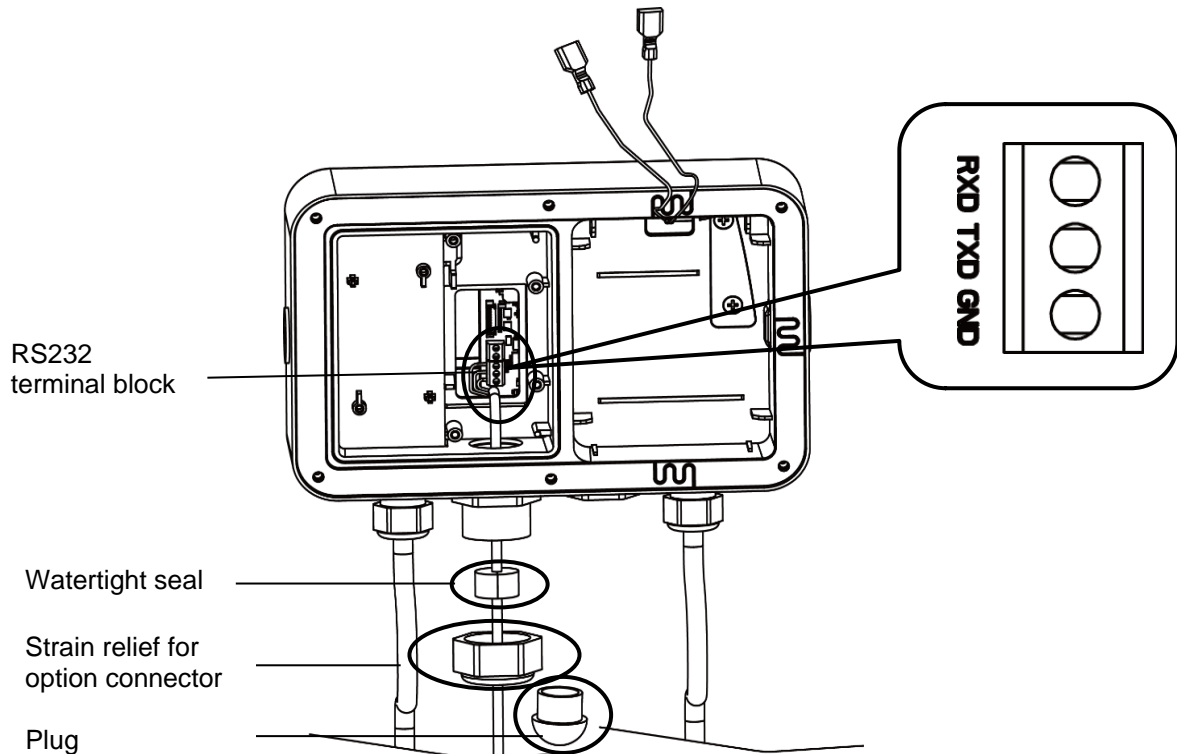

Figure 2-6 i-DT33XW RS232 Connection

2.4 Mounting Bracket

Attach the bracket to a wall or table using fasteners (not supplied) that are appropriate for the type of mounting surface. The bracket will accommodate up to 6 mm (1/4") diameter screws. Locate the mounting holes as shown in Figure 2-7 and 2-8.

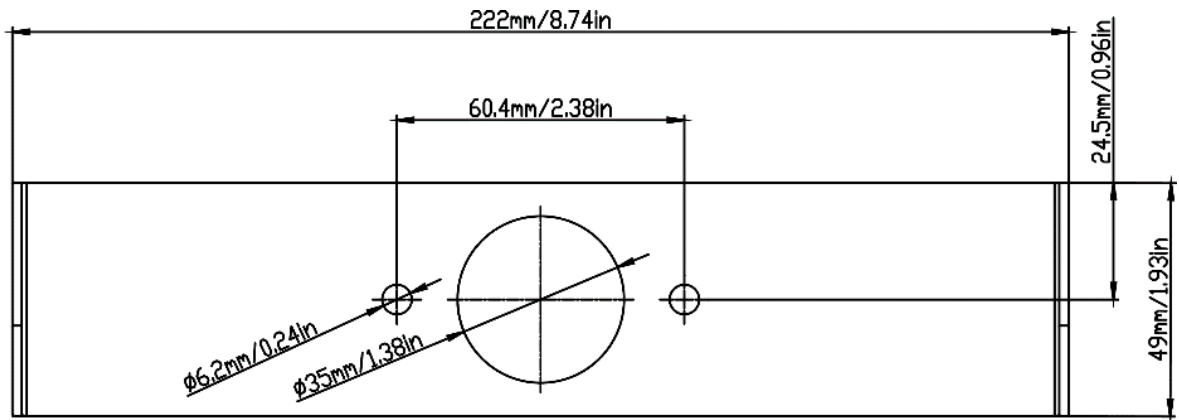

Figure 2-7 i-DT33P Mounting Bracket Dimensions

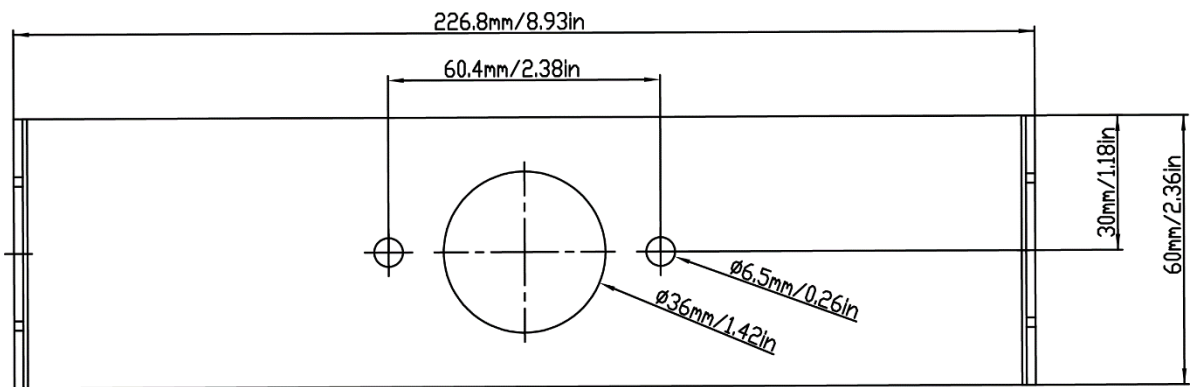

Figure 2-8 i-DT33XW Mounting Bracket Dimensions

3. OPERATION

3.1 Turning the Scale On/Off

To turn the scale on, short press the **On/Zero Off** button. The scale performs a display test, momentarily displays the software version, the GEO value and then enters the last active weighing mode.

Note: If the hardware lock switch is enabled, **LFLt ON** will also be displayed briefly.

To turn the scale off, press and hold the **On/Zero Off** button until **OFF** is displayed.

3.2 Weighing Mode

Use this application to determine the weight of items in the selected unit of measure. This mode is the default factory setting.

3.2.1 Enter the Mode and Start Weighing

To enter the weighing mode:

1. Press and hold the **Mode** button until **LWE IGH** is displayed.
2. If needed, place an empty container on the pan and press the **Tare** button to tare.

Note: To check the tare weight:

 - a) Long press the **Tare** button until **t.LWE** is displayed.
 - b) Release the **Tare** button and the tare weight will be displayed.
3. Add item to the pan or the container. The display shows the weight of the item.

3.2.2 Application Settings

The application can be customized for user preferences. To enter application settings:

1. Long press the **Menu** button until you see **APP.M.U.** Release the button and wait for the display to show **C.R.L.**
2. Short press the **No** button several times until you see **APP.d.E.** Press the **Yes** button to enter the application mode settings.
3. Short press the **No** button several times to navigate until you see the selection you want.
4. Press the **Yes** button to select.
5. Repeat step 3 and 4 several times until you finish all settings.
6. Press the **Exit** button to exit.

The Weighing configurations are defined below (defaults in Bold).

Item	Available Settings	Comments
Weighing (LWE IGH)	On, Off	To enable or disable Weighing

Note: You cannot disable Weighing if you are in the mode currently.

3.3 Counting Mode

Use this application to count the number of pieces on the pan based on an Average Piece Weight (APW).

3.3.1 Enter the Mode

1. Press and hold the **Mode** button until **Count** is displayed.
2. When the **Mode** button is released, the display shows **CLr.PWJ**.
 - If you need to clear the stored Average Piece Weight (APW) of the last time, press the **Yes** button, and then continue to the next step.
 - If you need to recall the stored APW of the last time and continue to use it, press the **No** button to start counting.

Note: If the display shows **CLr.PAN**, remove the weight on the pan or press the **Tare** button to tare.
3. The display shows the sample size **Pwt. 10**. To change it, short press the **No** button several times until you see the value you want.

Note:

 - Available sample size selections are 5, 10, 20, 50 and 100 (The default is 10).
 - When Legal for Trade is turned on, sample size selection 5 will not be available.
4. Place the specified quantity of pieces on the pan and press the **Yes** button to capture the current stable weight.

Note:

- Make sure all pieces in the sample are the same. Different pieces and weights will result in an inaccurate piece count.
- During the capture process, the display shows - - - - -.
- If the APW is between 0.1d and 1d, the display will show **LO.rEF** for 1.5 seconds. After that the scale will start counting.
- If the APW is less than 0.1d, the display will show **rEF.Err** for 1.5 seconds. After that it will go back to step 3, showing the sample size. Please replace a heavier batch of samples and press the **Yes** button to re-establish an APW value or change to a scale with readability suitable for your samples.

3.3.2 Start Counting

1. Place parts on the pan and read the number. The number of pieces and the Pcs icon are displayed.
2. Short press the **Function** button to temporarily display the APW. **APWJ** is displayed for 1 second, and then the APW value is displayed for 1 second with the weighing unit.

3.3.3 Application Settings

The application can be customized for user preferences. Please refer to **Application Settings** section in **Weighing Mode** for details about how to enter application settings.

The Counting Configurations are defined below (defaults in Bold).

Item	Available Settings	Comments
Count (Count)	On , Off	To enable Counting

Note: You cannot disable Counting if you are in the mode currently.

3.4 Check

Use this application to compare the weight of items to a target weight range.

The display color will change according to the comparing result:

- Red indicates over the target weight range
- Green indicates within the target weight range.
- Yellow indicates under the target weight range.

3.4.1 Set Check Limits

1. Press and hold the **Mode** button until **CHECK** is displayed.
 2. When the **Mode** button is released, the display shows **CLr.CHr**.
 - If you want to use the stored under and over value of the last time, press the **No** button, and the scale enters check mode directly.
 - If you want to set new over and under values, press the **Yes** button and continue to the next step.
 3. The display shows **Under**. Press the **Yes** button to edit the under value.
 4. **000000** is flashing on the display with the unit you set.
 5. To set a new under value:
 - a) Short press the **No** button several times until the desired number appears.

Note:

 - Press the **Back** button can decrease the digit.
 - If you need to set a negative value, press the **Back** button when the first digit is zero or press the **No** button when the first digit is nine.
 - b) Short press the **Yes** button to accept the number and move to the next digit.
 - c) Repeat the process until all the digits are correct.
 - d) Press the **Yes** button to accept the value. Then the display will show **Over**.

Note: Please refer to the **Button Navigation** section for details of setting digits.
 6. Repeat step 3 to 5 to set the over value.
 7. If the values you set are invalid, the display will show **--n0--** and go back to reset the Under and Over value.
 8. If the values you set are valid, the scale will enter check mode.
- Note:** Short press the **Function** button can display the over and under value.

3.4.2 Positive Check

Positive check is used to determine when the material added to the scale is within the target weight range. In this case the under and over values must be positive values. (The over value must be greater than the under value.)

To start, add material to the scale pan until the display turns green.

3.4.3 Negative Check

Negative check is used to determine when the material removed from the scale is within the target weight range. In this case the under and over values are both negative values. The under value must be greater than the over value. (For example: the under value is -10; the over value is -15).

To start, place a package or bin of material on the scale and press the **Tare** button.

Remove a portion of the package or material until the display turns green.

To continue weighing multiple portions off the scale's pan, tare the scale between each portion.

3.4.4 Zero Check

Zero check is used when comparing subsequent samples to an initial reference sample. In this case, the under value must be zero or a negative value and the over value must be zero or a positive one.

Place the reference sample on the scale and press the **Tare** button.

Remove material from the scale pan until the display turns green.

3.4.5 Application Settings

The application can be customized for user preferences. Please refer to **Application Settings** section in Weighing Mode for details about how to enter application settings.

The Check configurations are defined below (defaults in Bold).

Item	Available Settings	Comments
Check (CHECK)	On , Off	To enable or disable Check

Note: You cannot disable Check if you are in the mode currently.

3.5 Totalization

Use this application to manually or automatically accumulate the multiple weights. Statistical data (the number of samples, the total weight, the average weight, the minimum weight, the maximum weight and the difference in weight) is stored in memory for review and printing.

3.5.1 Application Settings

There are three totalization options:

- Off (**OFF**): disable the totalization function.
Manual (ᲠᲠᲠᲠᲠ): press the **Function** button to perform totalization manually.
 Auto (**ᲠᲠᲠᲠᲠ**): the scale will perform totalization automatically.
Note: The default is manual.

To set the totalization option:

1. Long press the **Menu** button until you see **ᲠᲠᲠᲠᲠ**. Release the button and wait for the display to show **ᲠᲠᲠᲠᲠ**.
2. Short press the **No** button several times to navigate until you see **ᲠᲠᲠᲠᲠ**, press the **Yes** button.
3. Short press the **No** button several times to navigate until you see **ᲠᲠᲠᲠᲠ**. Press the **Yes** button.
4. Short press the **No** button several times to navigate between different totalization options. The three options have been introduced above. Press the **Yes** button to confirm your selection.
5. Press the **Exit** button to exit.

3.5.2 Enter the Mode

1. Press and hold the **Mode** button until **ᲠᲠᲠᲠᲠ** is displayed.
2. When the **Mode** button is released, the display shows **ᲠᲠᲠᲠᲠ**.
 - If you need to clear the stored totalization result of the last time, press the **Yes** button, and then start totalization.
 - If you need to recall the stored totalization result of the last time, press the **No** button to continue the totalization of the last time.

Note: If there is weight on the pan, the display will show **ᲠᲠᲠᲠᲠ** until the weight is removed or you press the **Tare** button to tare.

3.5.3 Totalization Method

Manual

Place an item on the pan and press the **Function** button to add the weight to totalization.

Auto

Place an item on the pan. The displayed value is totalized automatically.

The flash of the Σ icon indicates the scale has totalized the weight successfully. It will keep flashing until the weight is removed and the pan is stable.

Notes:

- The item must be removed from the pan before the next item can be totalized.
- Only stable weights are stored.
- When Legal for Trade is turned ON, for NTEP models, gross and net weight cannot be added to the same total. If the first weight is recorded in gross, the future ones should be recorded in the same way. It is the same for the net weight.

3.5.4 View Totalization Result

When there is no weight on the pan, press the **Function** button to view the result.

The result includes the number of samples, the total weight, the average weight, the minimum weight, the maximum weight and the difference in weight (the maximum weight minus the minimum weight). The values are displayed for 1 second each.

3.5.5 Totalization Rules

The totalization operation will fail when:

1. The current weight is unstable.
2. The load's net weight is smaller than 5d.
3. The overall totalized number is larger than 999999. (The unit is according to what you set for the scale.)
4. The total number of totalization exceeds 9999 times.

3.5.6 Print Totalization Result and Format

- **During totalization, to print the current weight:**

1. Enable the Table on (**TABLE**) option in the menu.

To do this:

- a) Long press the **Menu** button until you see **TABLE**. Release the button and wait for the display to show **TABLE**.
- b) Short press the **No** button several times to navigate until you see **TABLE**. Press the **Yes** button.
- c) Short press the **No** button several times to navigate until you see **TABLE**. Press the **Yes** button.
- d) Short press the **No** button until you see **ON** flashing on the screen. Press the **Yes** button to enable.
- e) Press the **Exit** button to exit.

2. After the Table on option is enabled:

- In automatic totalization mode, the scale will automatically print the current weight when it is totalized successfully.
- In manual totalization mode, press the **Function** button to totalize the current weight and print it accordingly.

The print output for current weight will appear as the example below:

Example:

1.	1000 g G
2.	2000 g G
3.	3000 g G
4.	1999 g G
5.	1000 g G

- **When totalization is finished, to print the totalization result:**

1. Press the **Function** button with no weight on the pan to show the totalization result.
2. Press the **Print** button to print the result while the totalization result is displayed on the screen.

Note: if you do not press the **Function** button to display the totalization result, the scale will print the print template you set.

When totalization is finished, the print output for Totalization result will appear as the example below:

Example:

n:	5
Total:	8999 g
Avg:	1800 g
Min:	1000 g
Max:	3000 g
Diff:	2000 g

Note: The scale supports 32 characters and the left and right content will be aligned.

3.5.7 Application Settings

The application can be customized for user preferences. Please refer to **Application Settings** section in **Weighing Mode** for details about how to enter application settings.

The Totalization Configurations are defined below (defaults in Bold).

Item	Available Settings	Comments
Totalization (TOTAL)	Off, Auto, Manual	To select Totalization method or disable it

Note: you cannot disable Totalization if you are in the mode currently.

The Table Configurations are defined below (defaults in Bold).

Item	Available Settings	Comments
Table (TABLE)	On, Off	To enable or disable Table for printing current weight during Totalization

4. MENU SETTINGS

The User Menu allows the customizing of scale settings.

Note: Sub-menu for options (USB, Ethernet and Print2 in the table below) will be active only when the specific board is installed. See their separate option instruction manuals for additional setting information.

4.1 Menu Navigation

4.1.1 User Menu (in segments)

CAL	SEtUP	r.EAd	MOdE	U.n. It	A.S.2.3.2	P.r. I.N.t	U.S.b	E.t.H.N.E.t	P.r. I.N.t2	L.o.c.t	End
ZErD	rESEt	rESEt	rESEt	rESEt	rESEt	rESEt	rESEt	rESEt	rESEt	rESEt	rESEt
SPAN	C.UN It	StAbLE	WEIGH	kg	bAUD	ASSIGN	bAUD	IP.Addr	ASSIGN	L.ALL	
LINE	rANGE	ZErD	COUNT	g	PAR ItY	StAbLE	PAR ItY	u.E.r.	StAbLE	L.OFF	
GEO	CAP1	FILtEr	CHECT	lb	StOP	MOdE	StOP	ENd	MOdE	L.ZErD	
CtESEt	GrAd1	A2t	tOTAL	oz	H.SHARtE	t INtE	H.SHARtE		t INtE	L.Pr INt	
End	CAP2	b.LIGHt	tAbLE	lb:oz	ALt.P	L INtEo	ALt.P		L INtEo	L.UN It	
	GrAd2	b.COLOr	End	t	ALt.t	C.SUMm	ALt.t		C.SUMm	L.MOdE	
	P.ZErD	SCrEEN		End	ALt.2	tEMP	ALt.2		tEMP	L.MENU	
	P.UN It	A.OFF			End	End	End		ENd	L.tArE	
	A.tArE	P.SArE								End	
	End	CEC									
		End									

Notes:

Some modes/units may not be available in all models.

When LEGAL FOR TRADE is turned **ON** (the security switch S1 is in the locked position), the menu settings will be affected as below:

- Calibration function is disabled.
- Zero Range setting is locked at 2%.
- Stable Range setting is locked at 1d.
- Auto-Zero Tracking setting is locked at 0.5d.
- Filter and Units are locked at their current settings.
- Stable Only is locked at On.
- Lb:oz unit is locked at Off.
- Power saving mode is disabled.

Note: Please refer to **Legal for Trade** chapter for the position of the security switch S1.

4.1.2 Button Navigation

- The **Yes** button: allows entry into the displayed menu.
Accepts the displayed setting and advances to the next item.
- The **No** button: rejects entry into the displayed menu.
Rejects the displayed menu and moves on to the next selection.
- The **Back** button: moves backwards to the previous menu.
Returns to the previous displayed menu or selection.
- The **Exit** button: exits from user menu to the active weighing mode.

For menu items which need to set numbers such as the scale capacity, the current number is displayed with all digits flashing. To revise:

1. Press the **No** button to begin editing.

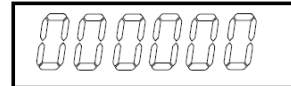

2. The first digit is displayed flashing.



3. Press the **No** button to increase the digit or press the **Yes** button to accept the digit and move to the next one.



Note: press the **Back** button can decrease the digit.

4. Repeat this process for all digits.



5. Press the **Yes** button when the last digit has been set.



6. The new setting is displayed with all digits flashing. Press the **Yes** button to accept the setting or press the **No** button to resume editing.

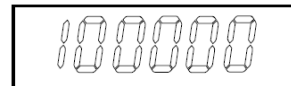

7. To end the current menu selection, press the **Yes** button to advance to the next menu, or press the **No** button to return to the top of the current menu.

4.2 Calibration Menu

Enter the calibration menu **C.A.L** to perform calibrations.

4.2.1 Initial Calibration

When the scale is operated for the first time, a zero and span calibration are recommended to ensure accurate weighing results.

Before performing the calibration, be sure to have the appropriate calibration weights as listed in table 4-1. Ensure that the LFT switch/calibration lock is set to the unlocked position.

You can also adjust the GEO setting according to your location. For detailed GEO information, please check the **Geo Code Adjustment** section below.

Table 4-1 Suggested Span Calibration Mass (Sold Separately)

Max Capacity (kg)	Mass* (kg)	Max Capacity (lb)	Mass* (lb)
3 kg	3 kg	6 lb	6 lb
6 kg	6 kg	12 lb	12 lb
15 kg	15 kg	30 lb	30 lb
30 kg	30 kg	60 lb	60 lb
60 kg	60 kg	120 lb	120 lb
150 kg	150 kg	300 lb	300 lb

Note: The calibration unit is consistent with the capacity unit.

4.2.2 Zero Calibration [ZEr0]

Zero calibration uses one calibration point. The zero calibration point is established with no weight on the scale. Use this calibration method to adjust for a different static load without affecting the span or linearity calibration.

Calibration procedures:

1. Long press the **Menu** button until you see **0.0.0.0**.
2. Release the button and wait for the display to show **C.A.L**. Press the **Yes** button.
3. The display shows **ZEr0**. Press the **Yes** button.
4. **0** kg and the calibration unit are flashing on the display. With no weight on the pan, press the **Yes** button to establish the zero point.
5. The display shows **--C--**, and then **-dONE-** when the Zero calibration is finished.

Note:

If zero calibration is failed or if after 40 seconds the calibration is still not successful, **CAL E** is displayed for 3 seconds and the previous calibration data will be restored.

6. Then the display shows **SPAN**. Press the **Exit** button to exit.

4.2.3 Span Calibration [SPAN]

Span calibration uses one calibration point. It is established with a calibration mass placed on the scale.

Note: Span calibration should be performed after zero calibration.

Calibration procedures:

1. Long press the **Menu** button until you see **0.0.0.0**.
2. Release the button and wait for the display to show **C.A.L**. Press the **Yes** button.
3. Short press the **No** button to navigate until you see **SPAN**. Press the **Yes** button.
4. The calibration point and the unit are flashing on the display based on the scale capacity and unit set in the menu. (e.g. **030.000** kg) If you do not need to change the calibration point, skip to step 6.
5. To change the calibration point:
 - a) Short press the **No** button several times until the desired number appears.
Note: press the **Back** button can decrease the digit.
 - b) Short press the **Yes** button to accept the number and move on to the next digit.

- c) Repeat the process until all the digits are correct.
- d) Press the **Yes** button to accept calibration point. It is flashing on the display.
6. Place a calibration mass of the specified weight on the pan and press the **Yes** button.
7. The display shows **--[--**, and then **-DONE-** when the calibration is finished.
8. Then the display shows **L 0**. Press the **Exit** button to exit.

Note:

- If calibration is failed, **CAL E** is displayed for 3 seconds and the previous calibration data is restored.
- If after waiting for 40 seconds the calibration is still not successful, **CAL E** is displayed for 3 seconds and the previous calibration data is restored.

4.2.4 Linearity Calibration [L 0]

Linearity calibration uses 3 calibration points. The full calibration point is established with a weight on the pan. The mid calibration point is established with a weight equal to half of the full calibration weight on the pan. The zero calibration point is established with no weight on the pan. The full calibration and mid calibration points can be altered by users during the calibration procedure.

Calibration procedures:

1. Long press the **Menu** button until you see **00.E.0.0**.
2. Release the button and wait for the display to show **C.A.L.** Press the **Yes** button.
3. Short press the **No** button several times to navigate until you see **L 0**. Press the **Yes** button.
4. **0** kg and the calibration unit are flashing on the display. With no weight on the pan, press the **Yes** button to establish the zero point. The display shows **--[--**.
5. Then the first calibration point and the unit are flashing on the display based on the scale capacity and unit you set in the setup menu. (For example, **0 15.000** kg). If you do not need to change the calibration point, skip to step 7.
6. To change the calibration point:
 - a) Short press the **No** button several times until the desired number appears.
Note: press the **Back** button can decrease the digit.
 - b) Short press the **Yes** button to accept the number and move on to the next digit.
 - c) Repeat the process until all the digits are correct.
 - d) Press the **Yes** button to accept calibration point. It is flashing on the display.
7. Place a calibration mass of the specified weight on the pan and press the **Yes** button. The display shows **--[--**.
8. The second calibration point and the unit are flashing on the display based on the capacity and unit you set in the setup menu. (For example, **030.000** kg)

Note:

If after waiting for 40s the calibration is still not successful, **CAL E** is displayed for 3 seconds and the previous calibration data is restored.

9. Repeat step 6 and 7.
10. The display shows **--[--**, and then **-DONE-** when the Linearity calibration is finished.
11. After that the display shows **GEO**. Press the **Exit** button to exit.

4.2.5 GEO Code Adjustment [GEO]

Geographical Adjustment Factor (GEO) code is used to adjust the calibration based on the current location. Settings from 0 to 31 are available with 12 being the default.

Please refer to the **Table of Geo Code Values** section in the **Technical Data** chapter to determine the GEO factor that corresponds to the indicator's location.

To set the GEO factor:

1. Long press the **Menu** button until you see **00.E.0.0**.
2. Release the button and wait for the display to show **C.A.L.** Press the **Yes** button.
3. Short press the **No** button several times to navigate until you see **GEO**. Press the **Yes** button.
4. The Geo point is flashing on the display (For example, **12**).

5. Short press the **No** button several times until the desired GEO number appears. Press the **Yes** button to accept.
Note: Press the **Back** button can decrease the digit.
6. Then the display shows **C.L.ESE**. Press the **Exit** button to exit.

4.2.6 Calibration Test [C.L.ESE]

Calibration test procedures:

1. Long press the **Menu** button until you see **M.E.U.**
2. Release the button and wait for the display to show **C.R.L.** Press the **Yes** button.
3. Short press the **No** button several times to navigate until you see **C.L.ESE**. Press the **Yes** button.
4. **0** and the calibration unit are flashing on the display based on the capacity and unit you set in the setup menu. With no weight on the pan, press the **Yes** button to establish the zero point.
5. The display shows **--E--** while the zero point is recorded.
6. The calibration weight and the unit of the last time are flashing on the display. (For example, **0 15.000** kg).
6. To change the test calibration weight:
 - a) Short press the **No** button several times until the desired number appears.
Note: press the **Back** button can decrease the digit.
 - b) Short press the **Yes** button to accept the number and move on to the next digit.
 - c) Repeat the process until all the digits are correct.
 - d) Press the **Yes** button to accept the calibration point. It is flashing on the display.
7. Place the specified test weight on the pan and press the **Yes** button.
8. The difference between the calibration data and the test weight is flashing on the display. (For example, **0.0 10** kg). If the indicator is connected to a printer or other devices, the result will be printed.
Note: the printed result will appear as below:
Example:

```

----- Cal Test -----
New Cal:6.0000kg
Old Cal:6.0000kg
Diff Cal:0.0000kg
Wt. ID:_____
----- End -----

```
9. After 5 seconds, the test ends and the scale returns to the active weighing mode, displaying the current weight.

4.2.7 End Cal [End]

When **End** is displayed, press the **Yes** button to exit this menu and advance to the next sub-menu, or press the **No** button to advance to the first menu item in the this sub-menu.

4.3 Setup Menu

Enter this menu **5.E.t.u.P** to set scale parameters. Default settings are in **bold**.

Menu	Sub-Menu	Sub-Menu (in segment)	Options	Options (in segment)
Setup 5.E.t.u.P	Reset	rESEt	no, yes	NO, YES
	Capacity Unit	C.uN tE	kg, lb	/
	Range	r-RNGE	Single , Dual	SINGLE, DUAL
	> 1 < Capacity	CRP	0.1-99999.9	/
	> 1 < Graduation	GrAd	0.0001~100	/
	> 2 < Capacity	CRP	0.1-99999.9	/
	> 2 < Graduation	GrAd	0.0001~100	/
	Power On Zero	P.ZEr0	Off, On	OFF, ON
	Power On Unit	P.uN tE	Auto , g, kg, lb, oz, lb:oz, t	AUTO
	Auto Tare	A.tArE	Off , On, Accept	OFF, ON, ACCEPT
	End	End	/	/

Note: / refers to not applicable in the table above.

Reset [rESEt]

Reset the Setup menu to factory defaults.

NO = do not reset
YES = reset

Capacity Unit [C.uN tE]

Select the unit used for calibration.

kg
lb

Range [r-RNGE]

Selects the number of weighing intervals.

This terminals can be configured to use single or dual interval. Each interval can be assigned its own graduation. If dual interval is selected, the graduation will change when the weight reaches the second interval.

When **Single** interval is selected, the additional parameters available are:

Capacity
Graduation

When **Dual** interval is selected, the terminal functions with two intervals, each with its own capacity and graduation. In addition to the Interval 1 capacity and graduation parameters, the following two parameters are available:

Capacity 2
Graduation 2

Capacity [CRP] / Capacity1 [CRP 1]

Set the capacity of the scale or the first capacity of the scale.
0.1-99999.9

Grad [GrAd] / Grad1 [GrAd 1]

Set the scale readability or the first readability of the scale.
0.0001~100

Capacity2 [CAP2]

Set the second capacity of the scale.

Grad2 [G-RAD2]

Set the second readability of the scale.

Note:

- The value of graduation 2 must be larger than graduation 1, and it applies to capacity as well.
- The capacity and graduation value should be within the following range, or your setting will be unsuccessful:

$$\text{Capacity} / 30000 \leq \text{Graduation} \leq \text{Capacity} / 600$$

Power On Zero [P.ZE-0]

Zero the scale at Power On.

OFF = disabled.

ON = enabled.

Power On Unit [P.ON U]

Set the unit that will be displayed at Power On.

AUTO = last unit in use when turned off

kg = kilograms

g = grams

lb = pounds

oz = ounces

lb:oz = pound ounces

t = metric tonne

Auto Tare [A.TAR-E]

Set the automatic tare feature.

OFF = automatic tare is disabled.

ON = the first stable gross weight is tared. The tared value will be cleared when the indicator returns to gross zero.

ACCEPT = stable gross weights within the Accept limits are tared (in Check mode only).

4.4 Readout Menu

Enter this menu to set user preferences. Default settings are in **bold**.

Menu	Sub-Menu	Sub-Menu (in segment)	Options	Options (in segment)
Read Out (r.E.R.d)	Reset	rESEt	no, yes	NO , YES
	Stability	StAbLE	0.5d, 1d , 2d, 5d	0.5d, 1d , 2d, 5d
	Zero Range	ZErO	2%, 100%	2, 100
	Filter Level	F ILtEr	Low, Medium , High	LOW , Med , HIGH
	Auto Zero Track	AZt	Off, 0.5d , 1d, 3d	OFF , 0.5d , 1d, 3d
	Back Light	b.L IGht	Off, On, Auto	OFF , ON, AUTO
	Back Light Color	b.COLOr	Green, Yellow, Red, Amber	GREEN , rEd, YELLow, AMBER
	Screen Saver	ScREEN	Off, 1min , 2min, 5min	OFF , 1, 2, 5
	Auto Off	A.OFF	Off , 1min, 5min, 10min	OFF , 1, 5, 10
	PWM.SAVE	P.SAVEr	ON , OFF	ON , OFF
	CEC	CEC	ON, OFF	ON, OFF
	End	End	/	/

Note: / refers to not applicable in the table above.

Reset [rESEt]

Reset the readout menu to factory defaults.

- NO** = do not reset.
YES = reset

Stability [StAbLE]

Set the amount reading can vary before the stability symbol turns off.

- 0.5d** = 0.5 of a scale division
1d = 1 scale division
2d = 2 scale divisions
5d = 5 scale divisions

Zero [ZErO]

Set the percentage of scale capacity that can be zeroed.

- 2%** = zero range is within +/-2%
100% = zero range is within +/-100%

Filter [F ILtEr]

Set the amount of signal filtering.

- LOW** = faster stabilization time with less stability.
Med = normal stabilization time with normal stability.
HIGH = slower stabilization time with more stability.

AZT [AZt]

Set the automatic zero tracking feature.

- OFF** = disabled
0.5d = the display will maintain zero until a change of 0.5 of a divisions per second has been exceeded.
1d = the display will maintain zero until a change of 1 division per second has been exceeded.
3d = the display will maintain zero until a change of 3 divisions per second has been exceeded.

Backlight [b.L IGht]

Set the display backlight feature.

- OFF** = backlight is disabled.

- ON** = backlight is enabled and always on.
AUTO = backlight is disabled after 20 seconds of no activity.

Backlight Color [b.COLOR]

Set the display backlight color.

- AMBER** = backlight color is amber.
GREEN = backlight color is green.
RED = backlight color is red.
YELLOW = backlight color is yellow.

Screen Saver [S.CEEN]

Set whether the screen saver is enabled after the selected time period.

- OFF** = screen saver is disabled
1 = the screen saver is enabled after 1 minute of no activity.
2 = the screen saver is enabled after 2 minutes of no activity.
5 = the screen saver is enabled after 5 minutes of no activity.

Auto Off [A.OFF]

Set whether the display enters sleep mode after the selected time period.

- OFF** = disabled
1 = the display enters sleep mode after 1 minute of no activity.
5 = the display enters sleep mode after 5 minutes of no activity.
10 = the display enters sleep mode after 10 minutes of no activity.

PWM.SAVE [P.SAVE]

Set whether to enable power saving mode after the scale enters standby mode. If it is enabled, it will take about 3 seconds before the indicator returns to weighing when weight is changed on the pan or you press the indicator's buttons.

- ON** = power saving is enabled.
OFF = power saving is disabled.

CEC [CEC]

Set whether to enable California Energy Commission function. When enabled, the energy plan complies with the California Energy Commission regulation.

- ON** = CEC is enabled.
OFF = CEC is disabled.

End Readout [End]

Advance to the next menu or return to the top of the current menu.

4.5 Unit Menu

Enter this menu **U.N. 1.t** to activate the desired units.

Reset
 Gram (g)
 Kilogram (kg)
 Pound (lb)
 Ounce (oz)
 Pound:Ounce (lb:oz)
 Metric Tonne (t)
 End

Note:

- Available units vary by model. In addition, due to national laws, the indicator may not include some of the units listed.
- If the security switch is turned on, the Units menu will be locked at their current setting.
- When the scale capacity is set to be more than 1000 kg, **Metric Tonne (t)** unit will appear in the Unit menu.

4.6 Communication

Enter this menu to define external communication methods and to set printing parameters. Data may be output to either a printer or PC. Factory default settings are shown in bold.

4.6.1 RS232 Menu

Enter this menu to define communication parameters.

Menu	Sub-Menu	Sub-Menu (in segment)	Options	Options (in segment)
RS232 (r.5.2.3.2)	Baud Rate	bAUD	300, 600, 1200, 2400, 4800, 9600 , 19200, 38400, 57600	/
	Parity	PAR 1.t	7 Even, 7 Odd, 7 None, 8 None	7 Even , 7 Odd , 7 None , 8 None
	Stop Bit	STOP	1 bit , 2 bit	1 bit , 2 bit
	Handshake	H.SHAKE	None , Xon/Xoff	None , ON-OFF
	Alt Print CMD	ALT.P	'A' ~ 'Z', P	/
	Alt Tare CMD	ALT.t	'A' ~ 'Z', T	/
	Alt Zero CMD	ALT.z	'A' ~ 'Z', Z	/
	Reset	rESET	no , yes	no , YES
End	End	/	/	

Note: / refers to not applicable in the table above.

Reset [**rESET**]

Reset the RS232 menu to factory defaults.

no = do not reset.
YES = reset

Baud Rate [**bAUD**]

Set the baud rate (bits per second).

300 = 300 bps
 600 = 600 bps
 1200 = 1200 bps
 2400 = 2400 bps
 4800 = 4800 bps
9600 = 9600 bps
 19200 = 19200 bps
 38400 = 38400 bps
 57600 = 57600 bps

Parity [PARITY]

Set the data bits and parity.

- 7 **EVEN** = 7 data bits, even parity
- 7 **ODD** = 7 data bits, odd parity
- 7 **NONE** = 7 data bits, no parity
- 8 **NONE** = 8 data bits, no parity

Stop bit [STOP]

Set the number of stop bits.

- 1 **bit** = 1 stop bits
- 2 **bit** = 2 stop bits

Handshake [HANDSHAKE]

Set the flow control method. Hardware handshaking is only available for COM1 menu.

- NONE** = no handshaking
- ON-OFF** = XON/XOFF software handshaking

Alternate Print command [ALT.P]

Set the alternate command character for Print.

Settings of A (a) to Z (z) are available. The default setting is **P**.

Alternate Tare command [ALT.T]

Set the alternate command character for Tare.

Settings of A(a) to Z(z) are available. The default setting is **T**.

Alternate Zero command [ALT.Z]

Set the alternate command character for Zero.

Settings of A (a) to Z (z) are available. The default setting is **Z**.

End [End]

Advance to the next menu or return to the top of the current menu.

4.6.2 Print Menu

Enter this menu to set printing parameters. Default settings are **bold**.

Menu	Sub-Menu	Sub-Menu (in segment)	Options	Options (in segment)
Print (P.r. t.a.t. t)/	Assignment	ᐱᑭᑭ ᐱᑭᐱ	Demand , Auto On Stable, Auto On Accept, Interval(seconds), MT-Continuous, OH-Continuous, SICS	ᐱᑭᐱᐱᐱ , ᐱᐱ.ᑭᑭᐱᑭ, ᐱᐱ.ᐱᑭᑭᐱ, ᐱᐱᑭᑭᑭ, ᐱᐱᑭᑭ.ᑭᐱᐱ, ᐱᐱᑭᑭ.ᑭᐱᐱ, ᑭ ᐱᑭᑭ
	Stable Weight Only [Demand]	ᑭᑭᐱᑭᑭ	Off , On(LFT Force On)	ᐱᐱᐱ , ᐱᐱ
	Mode [Auto On Stable]	ᐱᐱᐱᑭᑭ	Load , Load and Zero	ᑭᐱᐱᐱ , ᑭᐱᐱᐱᑭᑭ
	Time [Interval (seconds)]	ᑭ ᐱᐱᑭᑭ	1~5000	/
	Checksum [MT-Continuous]	ᑭ.ᑭᑭᐱᐱᐱ	On, Off	ᐱᐱᐱ , ᐱᐱᐱᐱ
	Link to [OH-Continuous]	ᑭ ᐱᐱᑭᑭᑭ	Off , Custom 1, Custom 2	ᐱᐱᐱᐱ . ᑭᐱᑭᑭ 1, ᑭᐱᑭᑭ 2
	Template	ᑭᑭᐱᐱᐱᐱ	Custom 1 , Custom 2	ᑭᐱᑭᑭ 1 , ᑭᐱᑭᑭ 2
	Reset	ᑭᑭᑭᑭᑭᑭ	no , yes	ᐱᐱ , ᑭᑭᑭᑭ
	End	ᑭᑭᑭᑭᑭᑭ	/	/

Note: / refers to not applicable in the table above.

Reset [ᑭᑭᑭᑭᑭᑭ]

Reset the Print menu to factory defaults.

- ᐱᐱ** = do not reset.
- ᑭᑭᑭᑭ** = reset

Assignment [ᐱᑭᑭ ᐱᑭᐱ]

Demand [ᐱᑭᐱᐱᐱᐱ]

If **Demand** is selected, the sub-menu **Stable Only** will display.

Set the printing criteria.

- ᐱᐱᐱᐱ** = values are printed immediately, regardless of stability.
- ᐱᐱ** = values are printed only when the stability criteria is met.

Auto On Stable [ᐱᐱ.ᑭᑭᐱᑭ]

If **Auto On Stable** is selected, the sub-menu **Mode** will display.

Set the printing mode.

- ᑭᐱᐱᐱ** = prints when the displayed load is stable.
- ᑭᐱᐱᐱᑭᑭ** = prints when the displayed load and zero reading are stable.

Auto On Accept [ᐱᐱ.ᐱᑭᑭᐱ]

If **Auto On Accept** is selected and the weighing mode is **Check**, values will be printed when the weight is accepted.

- ᐱᐱ.ᐱᑭᑭᐱ** = printing occurs each time the display is within the Accept range and stability criteria is met.

Interval [ᐱᑭᑭᑭᑭ]

If **Interval** is selected, the sub-menu **Time** will display.

- ᐱᑭᑭᑭᑭ** = printing occurs at the defined time interval.
- Settings of 1 to 5000 seconds are available. Default is 1.
Printing occurs at the defined time interval.

MT-Continuous [ጦገድ.ርግጥ]

If **MT-Continuous** is selected, the print output will be in the **MT-Continuous** format.

ጦገድ.ርግጥ = printing occurs continuously.

Note: Refer to Appendix A for **MT-Continuous** format.

ፎ.5ህጥጥ

Off = disabled

On = enabled

OH-Continuous [ፀዓ.ርግጥ]

If **OH-Continuous** is selected, the print output will be in the **OH-Continuous** format.

Note: Refer to Appendix D for **OH-Continuous** format.

ፀዓ.ርግጥ = printing occurs continuously.

ፊ ጠጉደፀ

OFF = disabled

ፎህኔ 1 = print using custom 1 template.

ፎህኔ 2 = print using custom 2 template.

SICS [5 ሳር5]

OFF = disable MT-SICS command

ፀጥ = enable MT-SICS command

Note: Refer to Appendix B for **SICS** commands.

End Print [ፎጎፈ]

Advance to the next menu or return to the top of the current menu.

Template [ፎፎጥጥፆ]

This sub-menu is used to define the format of the data output to a printer or computer.

ፎህኔ 1 = customized printout format.

ፎህኔ 2 = customized printout format.

Print template example:

0.000 kg

0.300 kg G

0.000 kg N

0.100 kg T

Connect the indicator to OHAUS ScaleMate software on a PC via the RS232 (or USB or Ethernet optional ports). To customize print template, you need to go to the ScaleMate software, Select **Print Template** on the top bar, and then double click items in the left column to select which ones you want to put in your print template.

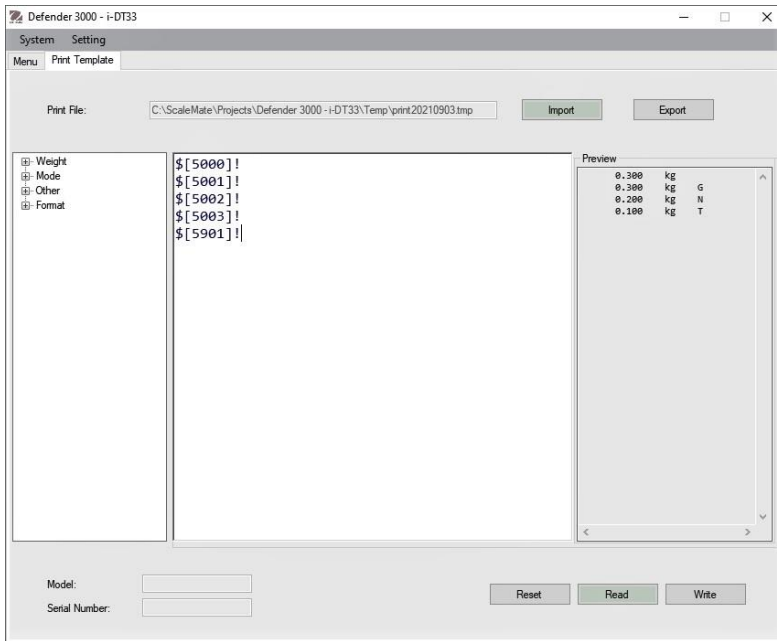

Note: Contact an authorized OHAUS dealer to obtain the ScaleMate software and learn more about the software's other functions.

Alternatively, you can also input the index number of the print items in the middle column directly to customize your print template in the software, using `$(XXXX)!` format. XXXX refers to the index number of each print item. Please check the following table for each item's index number.

Index Number	Print Items
5000	Result
5001	Gross
5002	Net
5003	Tare
5004	Displayed Weight
5005	Displayed Digit
5300	Mode
5301	Information (APW value in Counting; Under and Over Value in Check; Totalization result in Total)
5403	Indicator's Serial Number
5900	New Line
5901	End of Template
5902	Header Line 1
5903	Header Line 2
5904	Header Line 3
5905	Header Line 4
5906	Header Line 5

4.6.3 USB Configuration

Please refer to USB Configuration in the *Defender™ 3000 USB Interface Instruction Manual*.

4.6.4 Ethernet Configuration

Please refer to Configuration in the *Defender™ 3000 Ethernet Interface Instruction Manual*.

4.7 Lock Button Configuration

This menu **L.O.C.F** is used to lock access to certain buttons. When you select ON for one selection, the associated button press will be ignored.

If you select **Lock All Keys**, you will lose function of all buttons.

If the **Menu** button has been locked, long press the **Menu** button for 15 seconds until you see **UN.LOCK**. Press the **Yes** button to confirm.

Item	Available Settings (bold is the default settings)
Lock All Keys [L.ALL]	OFF, ON
Lock Off Key [L.OFF]	OFF, ON
Lock Zero Key [L.ZER0]	OFF, ON
Lock Print Key [L.Prnt]	OFF, ON
Lock Unit Key [L.UNIT]	OFF, ON
Lock Mode Key [L.Mode]	OFF, ON
Lock Menu Key [L.MENU]	OFF, ON
Lock Tare key [L.TARE]	OFF, ON
Reset	NO, YES

5. LEGAL FOR TRADE

When the indicator is used in trade or a legally controlled application, it must be set up, verified and sealed in accordance with local weights and measures regulations. It is the responsibility of the purchaser to ensure that all pertinent legal requirements are met.

5.1 Settings

Before verification and sealing, perform the following steps:

1. Verify that the menu settings meet the local weights and measures regulations.
2. Perform a calibration as explained in **Calibration Menu** section.
3. Turn the indicator off.

To turn the security switch on:

1. Disconnect power from the indicator and open the housing as demonstrated in **Open the Housing** section.

Note:

- Remove dry batteries for i-DT33P if used.
 - Remove the lead-acid battery if it is included in your i-DT33P model. Please refer to **Open the Housing** section **i-DT33P (with Lead-acid Battery)** sub-section for instruction.
 - Remove the first layer built-in housing including the lead-acid battery for i-DT33XW. Please refer to **Scale Base without EasyConnect™** section for instruction.
2. Turn the position of the security switch (S1) to ON. Refer to the following two graphics for the location of S1.

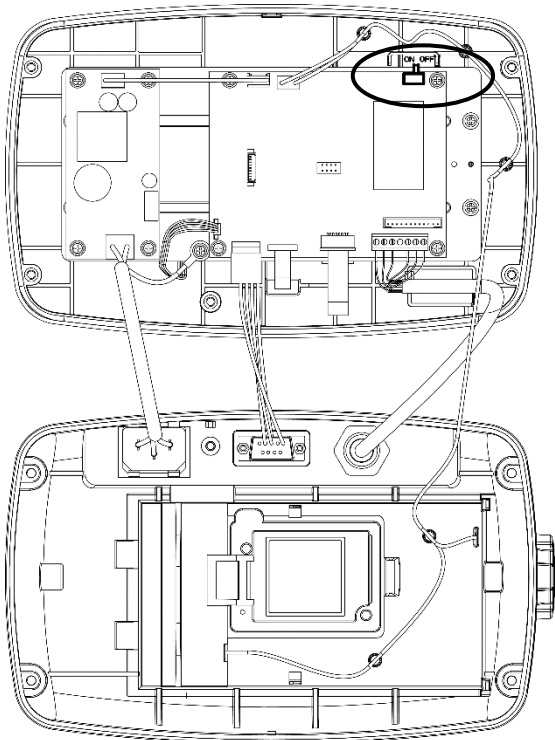

Figure 5-1 i-DT33P Security Switch (S1)
Location

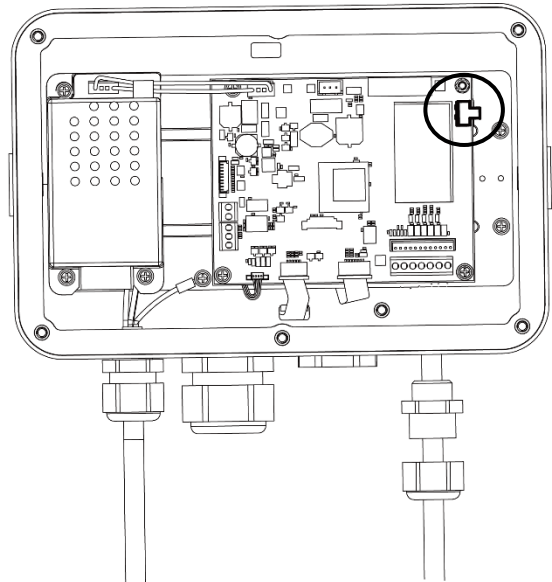

Figure 5-2 i-DT33XW Security Switch (S1)
Location

3. Close the housing. Re-install the lead-acid battery/dry batteries mentioned in step 1.
4. Reconnect the power and turn the indicator on.

5.2 Verification

The local weights and measures official or authorized service agent must perform the verification procedure.

5.3 Sealing

After the scale has been verified, it must be sealed to prevent undetected access to the legally controlled settings. Refer to the illustrations below for sealing methods.

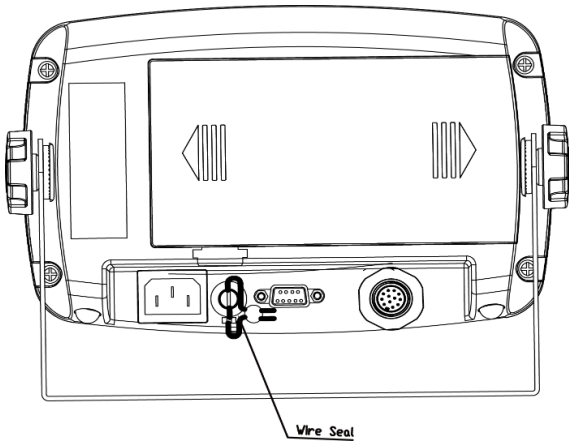

Figure 5-3. i-DT33P Wire Sealing

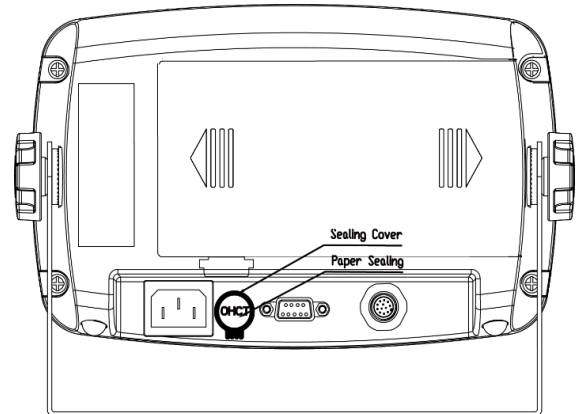

Figure 5-4. i-DT33P paper Sealing

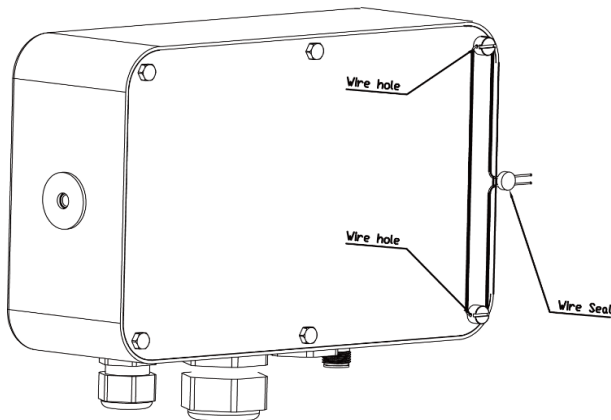

Figure 5-5. i-DT33XW Wire Sealing

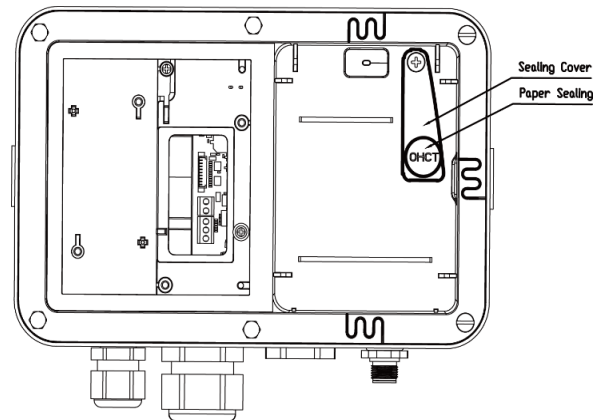

Figure 5-6. i-DT33XW Paper Sealing

For the sealing of the scale base, when the i-DT33P or i-DT33XW indicator is connected to an OHAUS Defender 3000 series base boasting EasyConnect™ function, it has a memory module on the load cell cable. The connection cable is sealed with software pairing, so no hardware sealing of the cable is needed. Once the indicator or the base is replaced by a new one, an error message (**Error 8.9**) will be shown on the indicator's display.

When the i-DT33P or i-DT33XW indicator is connected to a base that does not include a memory module, but supports load cell adapter connection, the connection between the indicator and the base shall be sealed by using a connector cover (P/N: 30538022), sealing sticker or wire seal.

i-DT33P

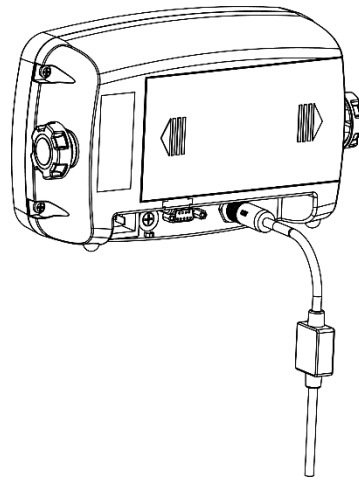

Figure 5-7. i-DT33P Sealing (Connecting cable with connector and memory module)

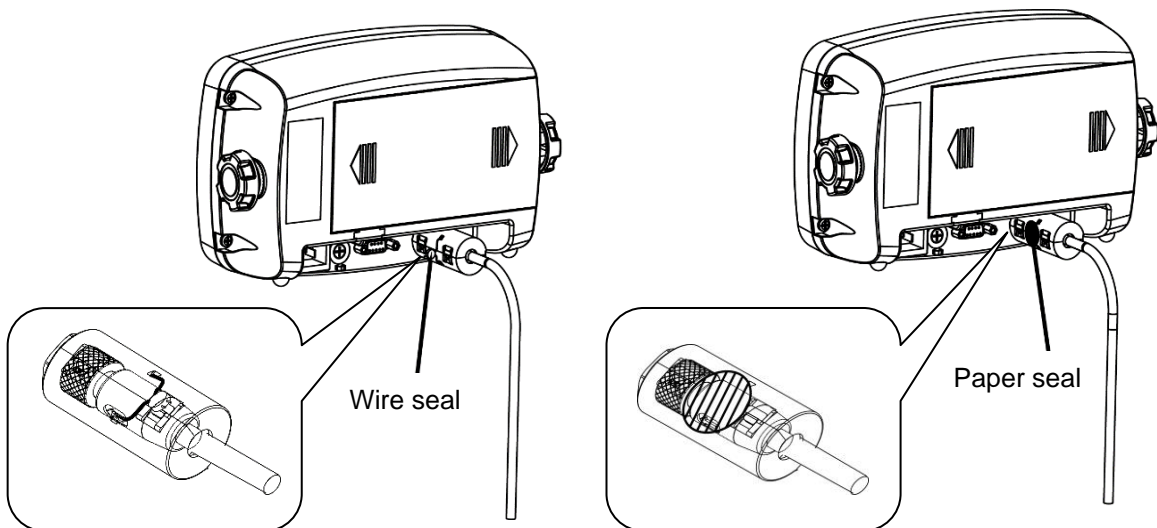

Figure 5-8. i-DT33P Sealing (Connecting cable with connector and without memory module)

i-DT33XW

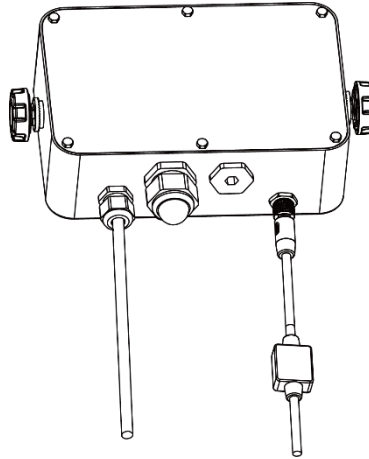

Figure 5-9. i-DT33XW Sealing (Connecting cable with connector and memory module)

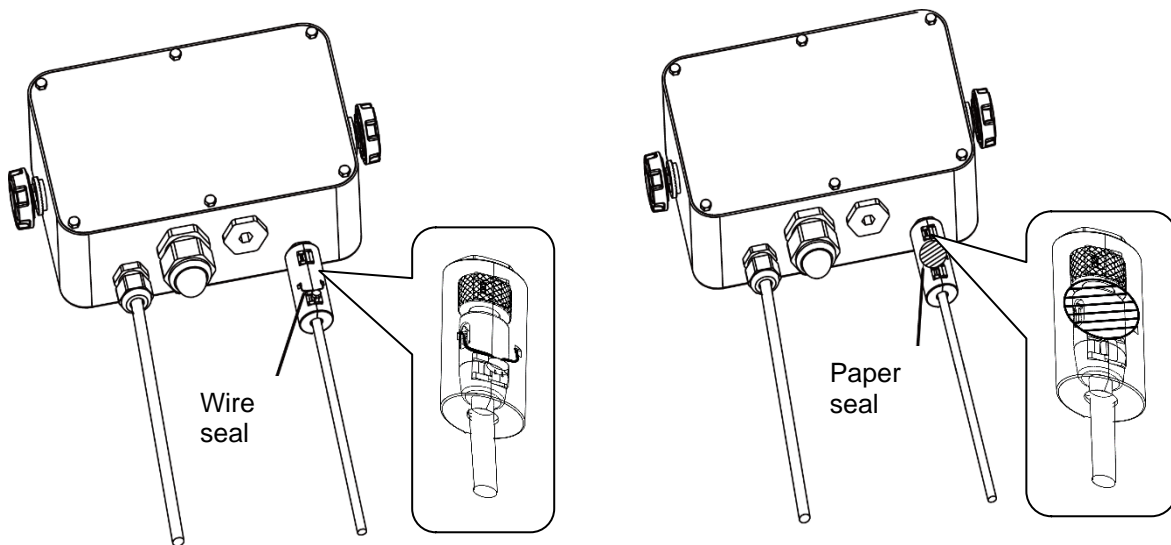

Figure 5-10. i-DT33XW Sealing (Connecting cable with connector and without memory module)

6. MAINTENANCE

CAUTION: DISCONNECT THE UNIT FROM THE POWER SUPPLY BEFORE CLEANING.

6.1 Cleaning

For i-DT33P, the housing may be cleaned with a cloth dampened with a mild detergent if necessary.

For i-DT33XW, use approved cleaning solutions for the stainless-steel Indicator housing and rinse with water. Dry thoroughly.



WARNING: Electric Shock Hazard. Disconnect the equipment from the power supply before cleaning. Make sure that no liquid enters the interior of the instrument.



Attention: Do not use solvents, harsh chemicals, ammonia or abrasive cleaning agents.

6.2 Troubleshooting

TABLE 6-1 Troubleshooting

SYMPTOM	PROBABLE CAUSE (s)	REMEDY
EEP Error	EEPROM Checksum Error	Corrupted EEPROM data
Unable to turn on the indicator.	<ol style="list-style-type: none"> 1. Power cord not plugged in or properly connected. 2. Power outlet not supplying electricity. 3. Battery discharged. 4. Other failure. 	<ol style="list-style-type: none"> 1. Check power cord connections. Make sure power cord is plugged in properly into the power outlet. 2. Check power source. 3. Recharge battery. 4. Service required.
Cannot zero the scale, or will not zero when turned on the indicator.	<ol style="list-style-type: none"> 1. Weights on the pan exceeds allowable limits. 2. Weight is not stable. 3. Load cell is damaged. 	<ol style="list-style-type: none"> 1. Remove weights on the pan. 2. Wait for weight to become stable, check area around the scale and weight on scale for excessive vibration or movement, or increase filtering. 3. Service required.
Unable to calibrate.	<ol style="list-style-type: none"> 1. LFT security switch is turned on. 2. Incorrect value for calibration mass. 	<ol style="list-style-type: none"> 1. Turn the LFT security switch off. 2. Use correct calibration mass.
Cannot display weight in desired weighing unit.	Unit is disabled.	Enable unit in the Units Menu. Refer to Unit Menu section for help.
Cannot change menu settings.	The Menu button has been locked.	<ol style="list-style-type: none"> 1. Enable the Menu button in the L.O.C.F Menu. 2. The LFT security switch may need to be switched off.
<i>Error 8.1</i>	Weight reading exceeds Power On Zero limit.	<ol style="list-style-type: none"> 1. Remove weight from the pan. 2. Recalibrate the scale.
<i>Error 8.2</i>	Weight reading below Power On Zero limit.	<ol style="list-style-type: none"> 1. Add weight to the pan. 2. Recalibrate the scale.
<i>Error 8.3</i>	Weight reading exceeds Overload limit.	Reduce weight on the pan.
<i>Error 8.4</i>	Weight reading below Underload limit.	<ol style="list-style-type: none"> 1. Add weight to the pan. 2. Recalibrate the scale.
<i>Error 8.8</i>	Factory calibration data in the EasyConnect™ module on load cell cable is not valid under LFT off status.	Calibrate the scale.
<i>Error 8.9</i>	Fail to read serial number from the EasyConnect™ module or the serial number does not match the LFT ON status.	<ol style="list-style-type: none"> 1. Break the seal or replace the original base/indicator. 2. Service required.
<i>Error 9.5</i>	Calibration data not presented.	Calibrate the scale.
Battery symbol flashing	Low battery	Replace dry batteries for i-DT33P model or recharge battery for i-DT33XW model.
<i>CAL E</i>	Calibration value outside allowable limits	Use correct calibration weight.
<i>REF Err</i>	The average piece of weight (APW) on the pan is too small and less than 0.1d.	Replace a heavier batch of samples or change to a scale with readability suitable for your samples.

Note: Please refer to the **LEGAL FOR TRADE** chapter, **Settings** section for the position of the LFT security switch for each model.

6.3 Service Information

If the troubleshooting section does not resolve your problem, contact an authorized OHAUS Service Agent. For Service assistance in the United States, call toll-free 1-800-526-0659 between 8:00 AM and 5:00 PM Eastern Standard Time. An OHAUS Product Service Specialist will be available to assist you. Outside the USA, please visit our website www.ohaus.com to locate the OHAUS office nearest you.

7. TECHNICAL DATA

7.1 Specifications

Equipment Ratings:

Indoor use only	
Altitude:	2,000m
Operating temperature:	-10°C to 40°C
Humidity:	Maximum relative humidity 80% for temperatures up to 31 °C decreasing linearly to 50% relative humidity at 40°C.
Electrical supply:	100 - 240V~, 0.5A, 50/60Hz
Voltage fluctuations:	Mains supply voltage fluctuations up to ±10% of the nominal voltage.
Overvoltage category (Installation category):	II
Pollution degree:	2

Model	i-DT33P
Construction	ABS plastic housing, powder coated carbon steel bracket
Maximum displayed resolution	1:30,000
Maximum approved resolution	1:10,000 or 2 × 3,000e Class III @ 1 μV/e (EC, OIML); 1:6,000 (NTEP/Measurement Canada) Class III
Weighing units	Kilogram, Gram, Pound, Ounce, Pound: Ounce, Tonne (Metric Tonne)
Modes	Weighing, Counting, Check, Totalization
Display	45 mm / 1.8 in digit height LCD display with 4-color backlight
Check indicator	3 color (red, green, yellow) bar
Keyboard	4 button membrane keyboard
Auto-zero tracking	Off, 0.5 d, 1 d or 3 d
Load cell excitation voltage	5VDC
Load cell drive	Up to 6 X 350 ohm
Load cell input sensitivity	Up to 3 mV/V
Stabilization time	1 second
Power	9 VDC, 6 dry cells, size C; 6 VDC rechargeable battery; 100-240 VAC / 50-60 Hz internal power supply (depending on models)
Battery life	Dry cell battery: up to 200 hours continuous use with backlight off Rechargeable battery: up to 100 hours continuous use with backlight off
Interface	RS232 standard, Optional USB device or Ethernet
Shipping dimensions	300 x 265 x 135 mm 11.8 x 10.4 x 5.3 in
Product dimensions (with bracket)	252 x 176 x 80 mm / 9.9 x 6.9 x 3.1 in
Approx. net weight	1.3 kg / 2.9 lb
Approx. shipping weight	1.6 kg / 3.5 lb
Operating temperature range	-10°C to 40°C / 14°F to 104°F

Model	i-DT33XW
Construction	304 stainless steel housing, 304 stainless steel bracket
Protection	IP66
Maximum displayed resolution	1:30,000
Maximum approved resolution	1:10,000 or 2 x 3,000e Class III @ 1 μ V/e (EC, OIML) 1:6,000 (NTEP/Measurement Canada) Class III
Weighing units	Kilogram, Gram, Pound, Ounce, Pound: Ounce, Tonne (Metric Tonne)
Modes	Weighing, Counting, Check, Totalization
Display	45 mm / 1.8 in digit height LCD display with 4-color backlight
Check indicator	3 color (red, green, yellow) bar
Keyboard	4 button membrane keyboard
Auto-zero tracking	Off, 0.5 d, 1 d or 3 d
Load cell excitation voltage	5VDC
Load cell drive	Up to 6 X 350 ohm
Load cell input sensitivity	Up to 3 mV/V
Stabilization time	1 second
Power	6 VDC rechargeable battery; 100-240 VAC / 50-60 Hz internal power supply
Battery life	Up to 100 hours continuous use with backlight off
Interface	RS232 standard, Optional USB device or Ethernet
Shipping dimensions	300 x 265 x 135 mm 11.8 x 10.4 x 5.3 in
Product dimensions (with bracket)	260 x 204 x 74 mm / 10.2 x 8.0 x 2.9 in
Approx. net weight	3.1 kg / 6.8 lb
Approx. shipping weight	3.4 kg / 7.5 lb
Operating temperature range	-10°C to 40°C / 14°F to 104°F





7.2 Table of Geo Code Values

TABLE 7-1 GEO CODES

Latitude		Elevation in meters										
		0	325	650	975	1300	1625	1950	2275	2600	2925	3250
		325	650	975	1300	1625	1950	2275	2600	2925	3250	3575
		Elevation in feet										
Latitude		0	1060	2130	3200	4260	5330	6400	7460	8530	9600	10660
		1060	2130	3200	4260	5330	6400	7460	8530	9600	10660	11730
		GEO value										
0°00'	5°46'	5	4	4	3	3	2	2	1	1	0	0
5°46'	9°52'	5	5	4	4	3	3	2	2	1	1	0
9°52'	12°44'	6	5	5	4	4	3	3	2	2	1	1
12°44'	15°06'	6	6	5	5	4	4	3	3	2	2	1
15°06'	17°10'	7	6	6	5	5	4	4	3	3	2	2
17°10'	19°02'	7	7	6	6	5	5	4	4	3	3	2
19°02'	20°45'	8	7	7	6	6	5	5	4	4	3	3
20°45'	22°22'	8	8	7	7	6	6	5	5	4	4	3
22°22'	23°54'	9	8	8	7	7	6	6	5	5	4	4
23°54'	25°21'	9	9	8	8	7	7	6	6	5	5	4
25°21'	26°45'	10	9	9	8	8	7	7	6	6	5	5
26°45'	28°06'	10	10	9	9	8	8	7	7	6	6	5
28°06'	29°25'	11	10	10	9	9	8	8	7	7	6	6
29°25'	30°41'	11	11	10	10	9	9	8	8	7	7	6
30°41'	31°56'	12	11	11	10	10	9	9	8	8	7	7
31°56'	33°09'	12	12	11	11	10	10	9	9	8	8	7
33°09'	34°21'	13	12	12	11	11	10	10	9	9	8	8
34°21'	35°31'	13	13	12	12	11	11	10	10	9	9	8
35°31'	36°41'	14	13	13	12	12	11	11	10	10	9	9
36°41'	37°50'	14	14	13	13	12	12	11	11	10	10	9
37°50'	38°58'	15	14	14	13	13	12	12	11	11	10	10
38°58'	40°05'	15	15	14	14	13	13	12	12	11	11	10
40°05'	41°12'	16	15	15	14	14	13	13	12	12	11	11
41°12'	42°19'	16	16	15	15	14	14	13	13	12	12	11
42°19'	43°26'	17	16	16	15	15	14	14	13	13	12	12
43°26'	44°32'	17	17	16	16	15	15	14	14	13	13	12
44°32'	45°38'	18	17	17	16	16	15	15	14	14	13	13
45°38'	46°45'	18	18	17	17	16	16	15	15	14	14	13
46°45'	47°51'	19	18	18	17	17	16	16	15	15	14	14
47°51'	48°58'	19	19	18	18	17	17	16	16	15	15	14
48°58'	50°06'	20	19	19	18	18	17	17	16	16	15	15
50°06'	51°13'	20	20	19	19	18	18	17	17	16	16	15
51°13'	52°22'	21	20	20	19	19	18	18	17	17	16	16
52°22'	53°31'	21	21	20	20	19	19	18	18	17	17	16
53°31'	54°41'	22	21	21	20	20	19	19	18	18	17	17
54°41'	55°52'	22	22	21	21	20	20	19	19	18	18	17
55°52'	57°04'	23	22	22	21	21	20	20	19	19	18	18
57°04'	58°17'	23	23	22	22	21	21	20	20	19	19	18
58°17'	59°32'	24	23	23	22	22	21	21	20	20	19	19
59°32'	60°49'	24	24	23	23	22	22	21	21	20	20	19
60°49'	62°00'	25	24	24	23	23	22	22	21	21	20	20
62°00'	63°30'	25	25	24	24	23	23	22	22	21	21	20
63°30'	64°55'	26	25	25	24	24	23	23	22	22	21	21
64°55'	66°24'	26	26	25	25	24	24	23	23	22	22	21
66°24'	67°57'	27	26	26	25	25	24	24	23	23	22	22
67°57'	69°35'	27	27	26	26	25	25	24	24	23	23	22
69°35'	71°21'	28	27	27	26	26	25	25	24	24	23	23
71°21'	73°16'	28	28	27	27	26	26	25	25	24	24	23
73°16'	75°24'	29	28	28	27	27	26	26	25	25	24	24
75°24'	77°52'	29	29	28	28	27	27	26	26	25	25	24
77°52'	80°56'	30	29	29	28	28	27	27	26	26	25	25
80°56'	85°45'	30	30	29	29	28	28	27	27	26	26	25
85°45'	90°00'	31	30	30	29	29	28	28	27	27	26	26

8. COMPLIANCE

Compliance to the following standards is indicated by the corresponding mark on the product.

Mark	Standard
	This product complies with the applicable harmonized standards of EU Directives 2011/65/EU (RoHS), 2014/30/EU (EMC), 2014/35/EU (LVD) and 2014/31/EU (NAWI). The EU Declaration of Conformity is available online at www.ohaus.com/ce .
	This product complies with the applicable statutory standards of the Restriction of the Use of Certain Hazardous Substances in Electrical and Electronic Equipment Regulations 2012, UK Electromagnetic Compatibility Regulations 2016, Electrical Equipment (Safety) Regulations 2016 and Non-Automatic Weighing Instruments Regulations 2016. The UK Declaration of Conformity is available online at www.ohaus.com/uk-declarations .
	This product complies with the EU Directive 2012/19/EU (WEEE) and 2006/66/EC (Batteries). Please dispose of this product in accordance with local regulations at the collecting point specified for electrical and electronic equipment. For disposal instructions in Europe, refer to www.ohaus.com/wEEE .
	EN 61326-1
	UL 61010-1 CAN/CSA-C22.2 No. 61010-1

ISED Canada Compliance Statement:

CAN ICES-003(A) / NMB-003(A)

ISO 9001 Registration

The management system governing the production of this product is ISO 9001 certified.

FCC Supplier Declaration of Conformity

Unintentional Radiator per 47CFR Part B
Trade Name: OHAUS CORPORATION
Model or Family identification: Defender 3000 series

Party issuing Supplier's Declaration of Conformity:

Ohaus Instruments (Changzhou) Co., Ltd.
2F, 22 Block, 538 West Hehai Road, Xinbei District, Changzhou
Jiangsu 213022
China
Phone: +86 519 85287270

Responsible Party – U.S. Contact Information:

Ohaus Corporation
7 Campus Drive, Suite 310
Parsippany, NJ 07054
United States
Phone: +1 973 377 9000
Web: www.ohaus.com

FCC Compliance Statement:

Note: This equipment has been tested and found to comply with the limits for a Class A digital device, pursuant to part 15 of the FCC Rules. These limits are designed to provide reasonable protection against harmful interference when the equipment is operated in a commercial environment. This equipment generates, uses, and can radiate radio frequency energy and, if not installed and used in accordance with the instruction manual, may cause harmful interference to radio communications. Operation of this equipment in a residential area is likely to cause harmful interference in which case the user will be required to correct the interference at his own expense.

Changes or modifications not expressly approved by the party responsible for compliance could void the user's authority to operate the equipment.

9. APPENDICES

9.1 Appendix A

MT Standard Continuous Output

A checksum character can be enabled or disabled with continuous output. The data consists of 17 or 18 bytes as shown in the standard continuous output.

Table 9-1.

Non-significant weight data and tare data digits are transmitted as spaces. The continuous output mode provides compatibility with OHAUS products that require real-time weight data. the standard continuous output. Table 9-1 shows the format for the standard continuous output.

Table 9-1: Standard Continuous Output Format

Character	Status ²			Indicated Weight ³						Tare Weight ⁴								
	1	2	3	4	5	6	7	8	9	10	11	12	13	14	15	16	17	18
Data	STX ¹	SB-A	SB-B	SB-C	MSD	-	-	-	-	LSD	MSD	-	-	-	-	LSD	CR ⁵	CHK ⁶

Continuous Output Format Notes:

1. ASCII Start of Text character (02 hex), always transmitted.
2. Status bytes A, B and C. Refer to Table 5-2, Table 5-3, and Table 5-4 for details of the structure.
3. Displayed weight. Either gross or net weight. Six digits, no decimal point or sign. Insignificant leading zeroes are replaced with spaces.
4. Tare weight. Six digits of tare weight data. No decimal point in field.
5. ASCII Carriage Return <CR> character (0D hex).
6. Checksum, transmitted only if enabled in setup. Checksum is used to detect errors in the transmission of data. Checksum is defined as the 2's complement of the seven low order bits of the binary sum of all characters preceding the checksum character, including the <STX> and <CR> characters.

Table 9-2, Table 9-3, and Table 9-4 detail the status bytes for standard continuous output.

Table 9-2: Status Byte A Bit Definitions

Bits 2, 1, and 0			
2	1	0	Decimal Point Location
0	0	0	XXXXXX00
0	0	1	XXXXXX0
0	1	0	XXXXXX
0	1	1	XXXXX.X
1	0	0	XXXX.XX
1	0	1	XXX.XXX
1	1	0	XX.XXXX
1	1	1	X.XXXXX
Bits 4 and 3			
4	3	Build Code	
0	1	X1	
1	0	X2	
1	1	X5	
Bit 5			Always = 1
Bit 6			Always = 0

Table 9-3: Status Byte B Bit Definitions

Status Bits	Function
Bit 0	Gross = 0, Net = 1
Bit 1	Sign, Positive = 0, Negative = 1
Bit 2	Out of Range = 1 (Over Capacity or Under Zero)
Bit 3	Motion = 1, Stable = 0
Bit 4	lb = 0, kg = 1 (see also Status Byte C, bits 0, 1, 2)
Bit 5	Always = 1
Bit 6	Zero Not Captured after power-up = 1

Table 9-4: Status Byte C Bit Definitions

Bits 2, 1, and 0			Weight Description
2	1	0	
0	0	0	lb or kg, selected by Status Byte B, bit 4
0	0	1	grams (g)
0	1	0	metric tons (t)
0	1	1	ounces (oz)
1	0	0	not used
1	0	1	not used
1	1	1	tons (ton)
1	1	1	no units
Bit 3			Print Request = 1
Bit 4			Expand Data x 10 = 1, Normal = 0
Bit 5			Always = 1
Bit 6			Always = 0

9.2 Appendix B

MT-SICS Commands

	Command	Function
LEVEL 0	@	Reset the scale
	I0	Inquiry of all available SICS commands
	I1	Inquiry of SICS level and SICS versions
	I2	Inquiry of scale data
	I3	Inquiry of scale software version
	I4	Inquiry of serial number
	S	Send stable weight value
	SI	Send weight value immediately
	SIR	Send weight value repeatedly
	Z	Zero the scale
	ZI	Zero immediately
LEVEL 1	D	Write text into display
	DW	Weight display
	SR	Send and repeat stable weight value
	T	Tare
	TA	Tare value
	TAC	Clear tare
	TI	Tare immediately

	Command	Function
LEVEL 2	C2	Calibrate with the external calibration weight
	C3	Calibrate with the internal calibration weight
	I10	Inquire or set scale ID
	I11	Inquire of scale type
	P100	Print out on the printer
	P101	Print out stable weight value
	P102	Print out current weight value immediately
	SIRU	Send weight value in the current unit immediately and repeat
	SIU	Send weight value in the current unit immediately
	SNR	Send stable weight value and repeat after every weight change
	SNRU	Send stable weight value in the current unit and repeat after every weight change
	SRU	Send weight value in the current unit and repeat
	ST	After pressing the Transfer key, send the stable weight value
	SU	Send stable weight value in the current unit
LEVEL 3	M01	Weighing mode
	M02	Stability setting
	M03	Autozero function
	M19	Send calibration weight
	M21	Inquire/set weight unit
	PRN	Print out at every printer interface
	RST	Restart
	SFIR	Send weight value immediately and repeat quickly
	SIH	Send weight value immediately in high resolution
	SWU	Switch weight unit
	SX	Send stable data record
	SXI	Send data record immediately
	SXIR	Send data record immediately and repeat
	U	Switch weight unit

9.3 Appendix C

Commands listed in the following table will be acknowledged by the scale.

The scale will return "ES" for invalid commands.

Please add `\r\n` after each command to send. (`\r` refers to `\return`; `\n` refers to `\newline`)

OHAUS Commands

Command	Function
P	Print displayed weight (stable or unstable).
IP	Print displayed weight immediately (stable or unstable).
CP	Print weight continuously.
SP	Print weight when stable.
Z	Same as pressing Zero Key.
T	Same as pressing Tare Key.
TA	Set/inquiry of tare weight value. <ul style="list-style-type: none"> Set: TA <i>tare value unit</i> Example: TA 5 kg Inquiry: TA
U	Set/inquiry current display unit. <ul style="list-style-type: none"> Set: U <i>unit ID</i> Example: U 1 Please check the following table 9-1 for the ID of each unit. Inquiry: U
M	Set/inquiry current application mode. <ul style="list-style-type: none"> Set: M <i>application ID</i> Example: M 0 Please check the following table 9-2 for the ID of each application. Inquiry: M
PSN	Print indicator's serial number.
CU	Set/inquiry Under Limit (only in Check mode). <ul style="list-style-type: none"> Set: CU <i>under value unit</i> Example: CU 5 kg Inquiry: CU
CO	Set/inquiry Over Limit (only in Check mode). <ul style="list-style-type: none"> Set: CO <i>over value unit</i> Example: CO 6 kg Inquiry: CO
#	Set/inquiry Counting APW. <ul style="list-style-type: none"> Set: # <i>APW value unit</i> Example: # 6 kg Inquiry: #
PV	Print name, software revision and LFT ON (if LFT security switch is turned ON).
H x "text"	Enter print output string, x = string number (1-5), "text" = string text up to 40 alphanumeric characters.

Note:

- The italic content in each command needs to be filled with actual value.
- Space in each command is needed. Please pay attention to it when input commands.

Table 9-1 Unit ID

Unit ID	Unit Name	Abbreviation
0	Gram	g
1	Kilogram	kg
2	Ton	t
7	Pound	lb
8	Ounce	oz
20	Pound:Ounces	lb:oz

Table 9-2 Application ID

Application ID	Unit Name
0	Weighing
1	Counting
3	Check
6	Totalization

9.4 Appendix D

OH-continuous Print

- Format 1: For the printout result including interval and continuous printing mode of Check Weighing application

Field	Weight (Right aligned)	Space	Unit (Right aligned)	Space	Stability (?)	Space	T/N/G/PT (Right aligned)	Space	Application Status (Right aligned)	Term.
Length	11	1	5	1	1	1	2	1	6	2

Note: **Application Status** is fixed to 6 characters. The printed status will be "Under", "Accept" and "Over" for check weighing.

- Format 2: For Non Check Weighing applications' printout result

Field	Weight (Right aligned)	Space	Unit (Right aligned)	Space	Stability (?)	Space	T/N/G/PT (Right aligned)	Term.
Length	11	1	5	1	1	1	2	2

LIMITED WARRANTY

OHAUS products are warranted against defects in materials and workmanship from the date of delivery through the duration of the warranty period. During the warranty period OHAUS will repair, or, at its option, replace any component(s) that proves to be defective at no charge, provided that the product is returned, freight prepaid, to OHAUS. This warranty does not apply if the product has been damaged by accident or misuse, exposed to radioactive or corrosive materials, has foreign material penetrating to the inside of the product, or as a result of service or modification by other than OHAUS. In lieu of a properly returned warranty registration card, the warranty period shall begin on the date of shipment to the authorized dealer. No other express or implied warranty is given by OHAUS Corporation. OHAUS Corporation shall not be liable for any consequential damages.

As warranty legislation differs from state to state and country to country, please contact OHAUS or your local OHAUS dealer for further details



Ohaus Corporation
7 Campus Drive
Suite 310
Parsippany, NJ 07054 USA
Tel: +1 973 377 9000
Fax: +1 973 944 7177

With offices worldwide / Con oficinas en todo el mundo / Avec des bureaux partout dans le monde / Mit Büros weltweit / Con uffici in tutto il mondo
www.ohaus.com



P/N 30696592A © 2021 Ohaus Corporation, all rights reserved / todos los derechos reservados / tous droits réservés / alle Rechte vorbehalten / tutti i diritti riservati



Defender™ 3000 Series Base Instruction Manual

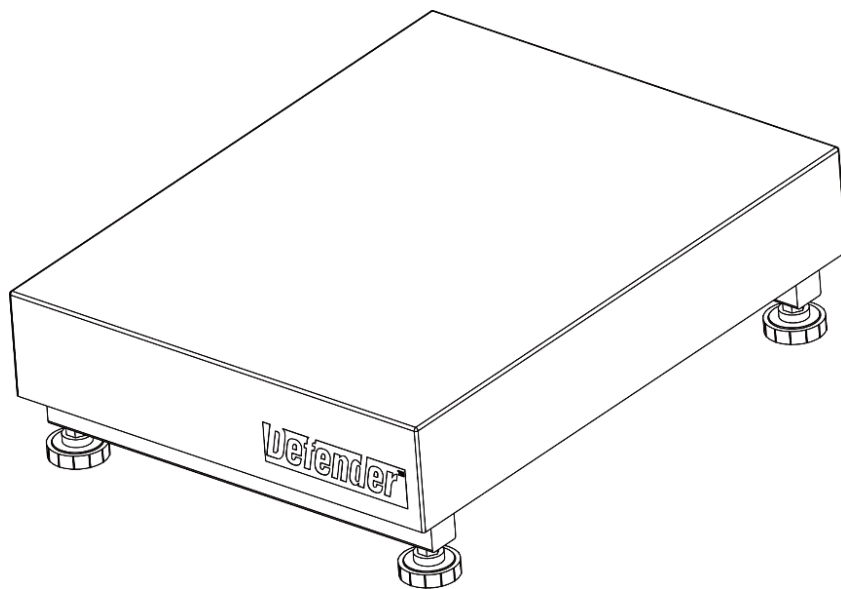

English

Español

Français

INTRODUCTION

This manual covers installation, and maintenance instructions for the OHAUS Defender™ Series Base. Please read this manual completely before installation and operation.

SAFETY PRECAUTIONS

For safe and dependable operation of this product, please comply with the following precautions:



- Operate the base only under ambient conditions specified in these instructions
- Ensure that the load cell cable does not pose an obstruction or tripping hazard
- Do not operate the base in hazardous environments or unstable locations
- Do not drop loads on the base
- Do not lift the base by the top frame; always lift from the bottom frame when moving the base
- Service should only be performed by authorized personnel

INSTALLATION

Unpacking

Unpack and inspect the product to make sure that all components have been included. The package includes the following:

- Defender™ Series Base
- Weighing Pan
- Instruction Manual

When purchased as a complete Defender Series Scale, the package will also include:

- Indicator
- Column Kit (Front-mount Kit)

ASSEMBLY

Weighing Pan

Remove the shipping spacers, and place the weighing pan securely over the rubber load pads on the top frame of the base.

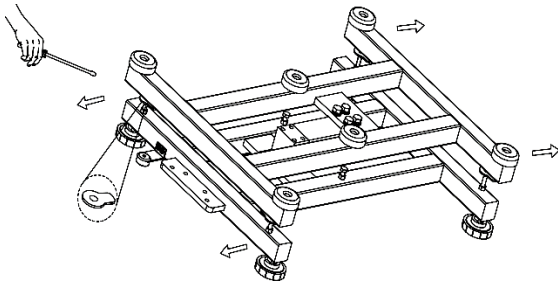

Note: Not included with some models

Wiring Connections

When connecting the base to an OHAUS indicator equipped with the matching circular connector, push the base connector onto the indicator connector and turn the locking ring clockwise to lock it in place.

When connecting the base to an indicator that does not have the matching connector, install the optional load cell cable adapter (P/N 30429931 sold separately) to the indicator using the wiring codes in Table 1. Then attach the load cell cable to the cable adapter.

Note: As an alternate wiring method, cut off the connector, strip the wires and attach them to the indicator using the wiring codes in Table 1.

The extension cable accessory (P/N: 30429931) cannot be used if the scale will be used in a legal for trade or legally controlled application, because there is no provision to seal the connection between the indicator and platform.

If your base does not support EasyConnect™, please refer to the indicator's manual for how to connect load cell connector.

TABLE 1. LOAD CELL CONNECTION

Type1. For model i-DxxxB1R, i-DxxxB1L base

FUNCTION	WIRE COLOR
+ Excitation	Red
- Excitation	Black
+ Signal	Blue
- Signal	White
Shield	Transparent

Type1. For model i-DxxxB1X, i-DxxxB1V base

FUNCTION	WIRE COLOR
+ Excitation	Red
- Excitation	Black
+ Signal	Green
- Signal	White
+ Sense	Blue
- Sense	Yellow
Shield	Transparent

Type2. For model i-DxxxC1x base

FUNCTION	WIRE COLOR
+ Excitation	Green
- Excitation	Black
+ Signal	Red
- Signal	White
+ Sense	Blue
- Sense	Brown
Shield	Yellow

Selecting the Location

To ensure accuracy, proper performance and safety, locate and operate the base on a stable, level surface. Avoid locations with rapid temperature changes or excessive dust, air currents, vibrations, electromagnetic fields or heat.

Level the base by adjusting the four leveling feet until the bubble in the level indicator is centered. A wrench may be needed to loosen the locking nut above each leveling foot. When the base is level, retighten the locking nuts up against the base to lock each foot into place.

Note: Ensure that the base is level each time its location is changed.

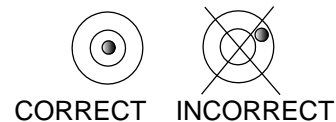

MAINTENANCE

Cleaning

The base components should be kept clean and free of excessive material build up.

- A damp cloth with water and a mild detergent may be used to wipe clean the external surfaces – do not use acids, alkalis, strong solvents or abrasive materials.

To maintain surface integrity, do not allow debris to remain on the surface of the painted or stainless steel base frame.

- Remove the pan and use fresh water to clean the base frame surface of any debris. Dry the base with a clean cloth or allow to air dry before replacing the pan. Repeat daily for best care.

Troubleshooting

Aside from installing components and leveling adjustments, the Defender Series Base does not require any other adjustments as shipped from the factory.

Operational difficulties that may be encountered can often be traced to simple causes such as:

- Loose or incorrect wiring connections
- Failure to remove the shipping spacers
- Obstructions to the base frame
- Unstable environments
- Incorrect calibration or setup of the indicator

If the troubleshooting section does not resolve or describe your problem, contact your authorized OHAUS service agent. For service assistance or technical support in the United States, call toll-free 1-800-526-0659 between 8:00 AM and 5:00 PM EST. An OHAUS product service specialist will be available to provide assistance. Outside the USA, please visit our web site, www.ohaus.com to locate the OHAUS office nearest you.

TECHNICAL DATA

Technical Specifications

The technical data is valid under the following ambient conditions:

Operating temperature: -10°C to +40 °C (14 °F to 104 °F)

Relative humidity: maximum relative humidity 80% for temperatures up to 31 °C decreasing linearly to 50% relative humidity at 40°C.

Altitude: Up to 2,000m

Pollution degree: 2

Note: Not all models may be available in your area. Check with your local OHAUS representative.

TABLE 2.1 SPECIFICATIONS

Model	i-D15B1R	i-D30B1R	i-D60B1R	i-D60B1L	i-D150B1L	i-D150B1X	i-D300B1X	i-D300B1V	i-D600B1V
Capacity	15 kg	30 kg	60 kg	60 kg	150 kg	150kg	300 kg	300 kg	600 kg
Approved Resolution	OIML 3000e								
Safe Overload Capacity	150% of capacity								
Pan Dimensions	305 x 355 mm			420 x 550 mm		500 x 650 mm		600 x 800 mm	
Base Construction	Stainless Steel platform with carbon steel frame and rubber leveling feet								
Load Cell Capacity	30 kg	50 kg	100 kg	100 kg	250 kg	250kg	500 kg	500kg	750kg
Load Cell Cable	2 m L x 4-wire					3 m L x 6-wire			
Load Cell Type	350 Ohm aluminum single point								
Load Cell Excitation	5-12V DC/AC								
Load Cell Rated Output	2 mV/V								
Net Weight	7 kg / 15.9 lb			13 kg / 28.8 lb		23 kg / 51.2 lb		41 kg / 90.6 lb	
Shipping Weight	10 kg / 22.5 lb			17 kg / 37.8 lb		27 kg / 58.9 lb		45 kg / 99.4 lb	
Load Cell Protection	IP65								

TABLE 2.2 SPECIFICATIONS

Model	i-D15C1R	i-D30C1R	i-D60C1R	i-D60C1L	i-D150C1L	i-D150C1X	i-D300C1X
Capacity	15 kg	30 kg	60 kg	60 kg	150 kg	150 kg	300 kg
Approved Resolution	OIML 3000e						
Safe Overload Capacity	150% of capacity						
Pan Dimensions	305 x 355 mm			420 x 550 mm		500 x 650 mm	
Base Construction	Stainless Steel platform with stainless steel frame and rubber leveling feet						
Load Cell Capacity	30 kg	50 kg	100 kg	100 kg	300 kg	300 kg	500 kg
Load Cell Cable	2 m L x 6-wire						
Load Cell Type	350 Ohm Stainless steel single point						
Load Cell Excitation	5-15V DC/AC						
Load Cell Rated Output	2 mV/V						
Net Weight	8 kg / 17.1 lb			14 kg / 30.7 lb		27 kg / 58.5 lb	
Shipping Weight	11 kg / 23.7 lb			18 kg / 39.6 lb		30 kg / 66.2 lb	
Load Cell Protection	IP67						

TABLE 2.3 SPECIFICATIONS

Model	i-D15B1R	i-D30B1R	i-D75B1R	i-D75B1L	i-D150B1L	i-D150B1X	i-D300B1X	i-D300B1V	i-D600B1V
Capacity	30 lb / 15 kg	60 lb / 30 kg	150 lb / 75 kg	150 lb / 75 kg	300 lb / 150 kg	300 lb / 150kg	600 lb / 300 kg	600 lb / 300 kg	1200 lb / 600 kg
Approved Resolution	NTEP and measurement Canada 3000e								
Safe Overload Capacity	150% of capacity								
Pan Dimensions	305 x 355 mm			420 x 550 mm		500 x 650 mm		600 x 800 mm	
Base Construction	Stainless Steel platform with carbon steel frame and rubber leveling feet								
Load Cell Capacity	30 kg	50 kg	100 kg	100 kg	250 kg	250kg	500 kg	500kg	750kg
Load Cell Cable	2 m L x 4-wire					3 m L x 6-wire			
Load Cell Type	350 Ohm aluminum single point								
Load Cell Excitation	5-12V DC/AC								
Load Cell Rated Output	2 mV/V								
Net Weight	7 kg / 15.9 lb			13 kg / 28.8 lb		23 kg / 51.2 lb		41 kg / 90.6 lb	
Shipping Weight	10 kg / 22.5 lb			17 kg / 37.8 lb		27 kg / 58.9 lb		45 kg / 99.4 lb	
Load Cell Protection	IP65								

TABLE 2.4 SPECIFICATIONS

Model	i-D15C1R	i-D30C1R	i-D75C1R	i-D75C1L	i-D150C1L	i-D150C1X	i-D300C1X
Capacity	30 lb / 15 kg	60 lb / 30 kg	150 lb / 75 kg	150 lb / 75 kg	300 lb / 150 kg	300 lb / 150 kg	600 lb / 300 kg
Approved Resolution	NTEP and measurement Canada 3000e						
Safe Overload Capacity	150% of capacity						
Pan Dimensions	305 x 355 mm			420 x 550 mm		500 x 650 mm	
Base Construction	Stainless Steel platform with stainless steel frame and rubber leveling feet						
Load Cell Capacity	30 kg	50 kg	100 kg	100 kg	300 kg	300 kg	500 kg
Load Cell Cable	2 m L x 6-wire						
Load Cell Type	350 Ohm Stainless steel single point						
Load Cell Excitation	5-15V DC/AC						
Load Cell Rated Output	2 mV/V						
Net Weight	8 kg / 17.1 lb			14 kg / 30.7 lb		27 kg / 58.5 lb	
Shipping Weight	11 kg / 23.7 lb			18 kg / 39.6 lb		30 kg / 66.2 lb	
Load Cell Protection	IP67						

Drawings

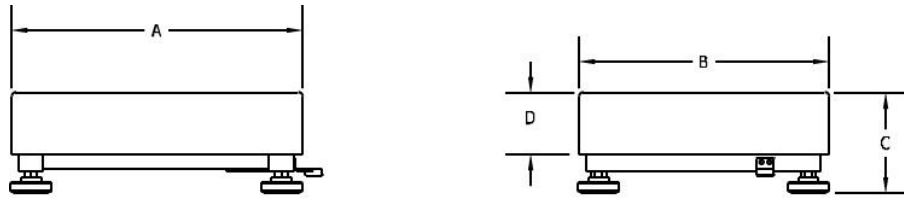

Figure 1. Defender Base Dimension Drawing.



TABLE 3. DIMENSIONS

Base	A	B	C	D
	Pan Depth	Pan Width	Height of Pan to Surface of Table	Height of Pan
i-DxxxB1R	355 mm / 14.0 in	305 mm / 12.0 in	128 mm / 5.3 in	75mm / 3.0 in
i-DxxxB1L	550 mm / 21.7 in	420 mm / 16.5 in	140 mm / 5.5 in	80 mm / 3.1in
i-DxxxB1X	650 mm / 25.6 in	500 mm / 19.7 in	150 mm / 5.9 in	90 mm / 3.5 in
i-DxxxB1V	800 mm / 31.5 in	600 mm / 23.6 in	154 mm / 6.1 in	90 mm / 3.5 in
i-DxxxC1R	355 mm / 14.0 in	305 mm / 12.0 in	128 mm / 5.0 in	75mm / 3.0 in
i-DxxxC1L	550 mm / 21.7 in	420 mm / 16.5 in	140 mm / 5.5 in	80 mm / 3.1in
i-DxxxC1X	650 mm / 25.6 in	500 mm / 19.7 in	150 mm / 5.9 in	90 mm / 3.5 in

*For leveling purposes, the feet may be extended up to an additional 15 mm.

COMPLIANCE

Compliance to the following standards is indicated by the corresponding mark on the product.

Mark	Standard
	This product complies with the applicable harmonized standards of EU Directives 2011/65/EU (RoHS). The EU Declaration of Conformity is available online at www.ohaus.com/ce .
	This product complies with the applicable statutory standards of the Restriction of the Use of Certain Hazardous Substances in Electrical and Electronic Equipment Regulations 2012. The UK Declaration of Conformity is available online at www.ohaus.com/uk-declarations .
	This product complies with the EU Directive 2012/19/EU (WEEE). Please dispose of this product in accordance with local regulations at the collecting point specified for electrical and electronic equipment. For disposal instructions in Europe, refer to www.ohaus.com/weee .

ISO 9001 Registration

The management system governing the production of this product is ISO 9001 certified.

ACCESSORIES

TABLE 4. ACCESSORIES

Part Number	Description
30616409	Wheel Kit Defender Series SST
30372146	Wheel Kit Defender Series CS
30696595	Column Assembly 330mm SST i-D33
30696596	Column Assembly 680mm SST i-D33
30696597	Column Assembly 330mm CS i-D33
30696598	Column Assembly 680mm CS i-D33
30696599	Column Assembly 980mm CS i-D33
30696600	Front Mount Kit i-D33

LIMITED WARRANTY

OHAUS products are warranted against defects in materials and workmanship from the date of delivery through the duration of the warranty period. During the warranty period OHAUS will repair, or, at its option, replace any component(s) that proves to be defective at no charge, provided that the product is returned, freight prepaid, to OHAUS. This warranty does not apply if the product has been damaged by accident or misuse, exposed to radioactive or corrosive materials, has foreign material penetrating to the inside of the product, or as a result of service or modification by other than OHAUS. In lieu of a properly returned warranty registration card, the warranty period shall begin on the date of shipment to the authorized dealer. No other express or implied warranty is given by OHAUS Corporation. OHAUS Corporation shall not be liable for any consequential damages.

As warranty legislation differs from state to state and country to country, please contact OHAUS or your local OHAUS dealer for further details

INTRODUCCIÓN

Este manual describe instrucciones de instalación y mantenimiento para la base de la serie Defender™ de OHAUS. Lea completamente este manual antes de la instalación y funcionamiento.

PRECAUCIONES DE SEGURIDAD

Para una operación segura y confiable de este producto, respete las siguientes precauciones:



- Opere la base solamente bajo las condiciones ambientales especificadas en estas instrucciones
- Asegúrese de que el cable de la celda de carga no represente un riesgo de obstrucción o de tropiezo
- No utilice la base en entornos peligrosos o en lugares inestables
- No deje caer cargas sobre la base
- No levante la base por medio de la parte superior del marco, levántela siempre por medio de la parte inferior al mover la base
- Cualquier reparación y servicio debe ser realizado solo por personal autorizado

INSTALACIÓN

Desembalaje

Desembale e inspeccione el producto para asegurarse de que incluye todos los componentes. El paquete contiene lo siguiente:

- Base de la serie Defender™
- Plato de pesaje
- Manual de instrucciones

Si es adquirida como una báscula de la serie Defender, el paquete también contiene:

- Indicador
- Kit de columna (Kit de montaje frontal)

MONTAJE

Plato de pesaje

Retire los espaciadores de envío y coloque el plato de pesaje firmemente sobre las almohadillas de caucho en el marco superior de la base.

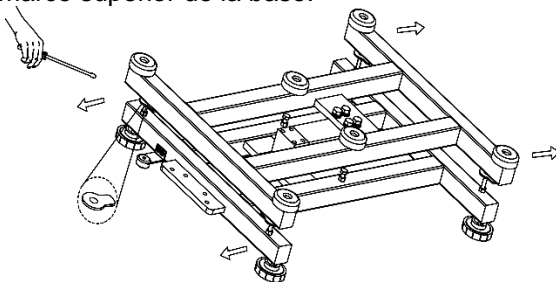

Nota: No incluido con algunos modelos.

Conexiones del cableado

Al conectar la base a un indicador OHAUS equipado con el correspondiente conector circular, empuje el conector de la base en el conector del indicador y gire el anillo de bloqueo para asegurarlo.

Si conecta la base a un indicador que no tenga el conector correspondiente, instale el adaptador opcional del cable de la celda de carga (P/N 30429931 vendido por separado) para el indicador utilizando los códigos de cableado en la tabla 1. A continuación conecte el cable de la celda de carga al adaptador del cable.

Nota: Como un método de cableado alternativo, corte el conector, pele los cables y conéctelos al indicador utilizando los códigos de cableado en la tabla 1.

El cable de extensión accesorio (P/N: 30429931) no puede utilizarse si la báscula va a tener un uso comercial legal o una aplicación controlada legalmente, ya que no existe disposición para sellar la conexión entre el indicador y plataforma.

Si su base no es compatible con EasyConnect™, consulte el manual del indicador para saber cómo conectar el conector de la célula de carga.

TABLA 1. CONEXIÓN DE LA CELDA DE CARGA

Tipo1. Para el modelo i-DxxxB1R, base i-DxxxB1L

FUNCIÓN	COLOR DEL CABLE
+ Excitación	Rojo
- Excitación	Negro
+ Señal	Azul
- Señal	Blanco
Blindaje	Transparente

Tipo1. Para el modelo i-DxxxB1V, base i-DxxxB1V

FUNCIÓN	COLOR DEL CABLE
+ Excitación	Rojo
- Excitación	Negro
+ Señal	Verde
- Señal	Blanco
+ Detección	Azul
- Detección	Amarillo
Blindaje	Transparente

Tipo2. Para el modelo i-DxxxC1x base

FUNCIÓN	COLOR DEL CABLE
+ Excitación	Verde
- Excitación	Negro
+ Señal	Rojo
- Señal	Blanco
+ Detección	Azul
- Detección	Marrón
Blindaje	Amarillo

Seleccionar la ubicación

Para garantizar la precisión, funcionamiento correcto y seguridad, coloque y opere la base sobre una superficie estable y nivelada. Evite los lugares con cambios rápidos de temperatura o exceso de polvo, corrientes de aire, vibraciones, campos electromagnéticos o calor.

Nivele la base ajustando los cuatro pies de nivelación hasta que la burbuja en el indicador de nivel quede centrada. Puede ser necesaria una llave para aflojar la tuerca de seguridad situada sobre cada pie de nivelación. Cuando la base esté nivelada, apriete las tuercas de seguridad contra la base para bloquear cada pie en su lugar.

Nota: Asegúrese de que la base esté nivelada cada vez que cambie su ubicación.

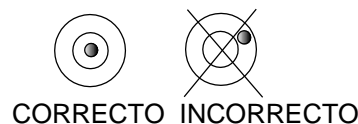

MANTENIMIENTO

Limpieza

Los componentes de la base deben mantenerse limpios y libre de acumulación excesiva de material.

- Puede utilizar un paño humedecido con agua y un detergente suave para limpiar las superficies externas, no use ácidos, álcalis, disolventes fuertes o materiales abrasivos.

Para mantener la integridad de la superficie, no permita que haya suciedad en la superficie pintada o de acero inoxidable de la estructura de la base.

- Retire el plato y utilice agua fresca para limpiar la superficie de la estructura de la base. Para secar la base, utilice un paño limpio o deje secar al aire antes de reemplazar el plato. Repetir diariamente para mantener un buen cuidado.

Solución de problemas

Aparte de instalar los componentes y ajustes de nivelación, la base de la serie Defender no requiere otros ajustes de los que se realizan en fábrica.

Las dificultades operativas que pueden encontrarse a menudo se remontan a causas simples tales como:

- Conexiones sueltas o incorrectas
- No haber retirado los espaciadores de envío
- Obstrucciones en la estructura de la base
- Entornos inestables
- Calibración o configuración incorrecta del indicador

Si la sección de solución de problemas no resuelve o describe su problema, póngase en contacto con su agente de servicio autorizado de OHAUS. Para asistencia de servicio o soporte técnico en los Estados Unidos llamar al número gratuito 1-800-526-0659, de 08:00 a.m. a 05:00 p.m. EST. Un especialista de servicio para productos OHAUS estará disponible para brindarle asistencia. Fuera de Estados Unidos visite nuestro sitio web www.ohaus.com para localizar la oficina de OHAUS más cercana a usted.

DATOS TÉCNICOS

Especificaciones técnicas

Los datos técnicos son válidos en las siguientes condiciones ambientales:

Temperatura de funcionamiento: -10 °C a +40 °C (14 °F a 104 °F)

Humedad relativa: humedad relativa máxima del 80 % para temperaturas de hasta 31 °C, disminuyendo linealmente hasta el 50 % de humedad relativa a 40 °C.

Altitud: Hasta 2,000 m

Grado de polución: 2

Nota: No todos los modelos pueden estar disponibles en su área. Consulte con su representante local de OHAUS.

TABLA 2.1 ESPECIFICACIONES

Modelo	i-D15B1R	i-D30B1R	i-D60B1R	i-D60B1L	i-D150B1L	i-D150B1X	i-D300B1X	i-D300B1V	i-D600B1V
Capacidad	15 kg	30 kg	60 kg	60 kg	150 kg	150kg	300 kg	300 kg	600 kg
Resolución aprobada	OIML 3000e								
Capacidad segura de sobrecarga	150 % de la capacidad								
Dimensiones del plato	305 x 355 mm			420 x 550 mm		500 x 650 mm		600 x 800 mm	
Construcción de la base	Plataforma de acero inoxidable con estructura de acero carbono y patas niveladoras de goma								
Capacidad de la celda de carga	30 kg	50 kg	100 kg	100 kg	250 kg	250kg	500 kg	500kg	750kg
Cable de la celda de carga	2 m L x 4-hilos					3 m L x 6-hilos			
Tipo de la celda de carga	350 Ohm, aluminio, un solo punto								
Excitación de la celda de carga	5-12V DC/AC								
Salida nominal de la célula de carga	2 mV/V								
Peso neto	7 kg / 15,9 lb			13 kg / 28,8 lb		23 kg / 51,2 lb		41 kg / 90,6 lb	
Peso de envío	10 kg / 22,5 lb			17 kg / 37,8 lb		27 kg / 58,9 lb		45 kg / 99,4 lb	
Protección de la celda de carga	IP65								

TABLA 2.2 ESPECIFICACIONES

Modelo	i-D15C1R	i-D30C1R	i-D60C1R	i-D60C1L	i-D150C1L	i-D150C1X	i-D300C1X
Capacidad	15 kg	30 kg	60 kg	60 kg	150 kg	150 kg	300 kg
Resolución aprobada	OIML 3000e						
Capacidad segura de sobrecarga	150 % de la capacidad						
Dimensiones del plato	305 x 355 mm			420 x 550 mm		500 x 650 mm	
Construcción de la base	Plataforma de acero inoxidable con estructura de acero inoxidable y patas niveladoras de goma						
Capacidad de la celda de carga	30 kg	50 kg	100 kg	100 kg	300 kg	300 kg	500 kg
Cable de la celda de carga	2 m L x 6-hilos						
Tipo de la celda de carga	350 Ohm, acero inoxidable, un solo punto						
Excitación de la celda de carga	5-15V DC/AC						
Salida nominal de la célula de carga	2 mV/V						
Peso neto	8 kg / 17,1 lb			14 kg / 30,7 lb		27 kg / 58,5 lb	
Peso de envío	11 kg / 23,7 lb			18 kg / 39,6 lb		30 kg / 66,2 lb	
Protección de la celda de carga	IP67						

TABLA 2.3 ESPECIFICACIONES

Modelo	i-D15B1R	i-D30B1R	i-D75B1R	i-D75B1L	i-D150B1L	i-D150B1X	i-D300B1X	i-D300B1V	i-D600B1V
Capacidad	30 lb / 15 kg	60 lb / 30 kg	150 lb / 75 kg	150 lb / 75 kg	300 lb / 150 kg	300 lb / 150 kg	600 lb / 300 kg	600 lb / 300 kg	1200 lb / 600 kg
Resolución aprobada	NTEP y medida de Canadá 3000e								
Capacidad segura de sobrecarga	150 % de la capacidad								
Dimensiones del plato	305 x 355 mm			420 x 550 mm		500 x 650 mm		600 x 800 mm	
Construcción de la base	Plataforma de acero inoxidable con estructura de acero carbono y patas niveladoras de goma								
Capacidad de la celda de carga	30 kg	50 kg	100 kg	100 kg	250 kg	250kg	500 kg	500kg	750kg
Cable de la celda de carga	2 m L x 4-hilos					3 m L x 6-hilos			
Tipo de la celda de carga	350 Ohm aluminio, un solo punto								
Excitación de la celda de carga	5-12V DC/AC								
Salida nominal de la célula de carga	2 mV/V								
Peso neto	7 kg / 15,9 lb			13 kg / 28,8 lb		23 kg / 51,2 lb		41 kg / 90,6 lb	
Peso de envío	10 kg / 22,5 lb			17 kg / 37,8 lb		27 kg / 58,9 lb		45 kg / 99,4 lb	
Protección de la celda de carga	IP65								

TABLA 2.4 ESPECIFICACIONES

Modelo	i-D15C1R	i-D30C1R	i-D75C1R	i-D75C1L	i-D150C1L	i-D150C1X	i-D300C1X
Capacidad	30 lb / 15 kg	60 lb / 30 kg	150 lb / 75 kg	150 lb / 75 kg	300 lb / 150 kg	300 lb / 150 kg	600 lb / 300 kg
Resolución aprobada	NTEP y medida de Canadá 3000e						
Capacidad segura de sobrecarga	150 % de la capacidad						
Dimensiones del plato	305 x 355 mm			420 x 550 mm		500 x 650 mm	
Construcción de la base	Plataforma de acero inoxidable con estructura de acero inoxidable y patas niveladoras de goma						
Capacidad de la celda de carga	30 kg	50 kg	100 kg	100 kg	300 kg	300 kg	500 kg
Cable de la celda de carga	2 m L x 6-hilos						
Tipo de la celda de carga	350 Ohm acero inoxidable, un solo punto						
Excitación de la celda de carga	5-15V DC/AC						
Salida nominal de la célula de carga	2 mV/V						
Peso neto	8 kg / 17,1 lb			14 kg / 30,7 lb		27 kg / 58,5 lb	
Peso de envío	11 kg / 23,7 lb			18 kg / 39,6 lb		30 kg / 66,2 lb	
Protección de la celda de carga	IP67						

PLANOS



Figura 1. Plano de dimensiones de la base Defender.



TABLA 3. DIMENSIONES

Base	A	B	C	D
	Profundidad del plato	Anchura del plato	Altura del plato a la superficie de la mesa	Altura del plato
i-DxxxB1R	355 mm / 14,0 in	305 mm / 12,0 in	128 mm / 5,3 in	75mm / 3,0 in
i-DxxxB1L	550 mm / 21,7 in	420 mm / 16,5 in	140 mm / 5,5 in	80 mm / 3,1in
i-DxxxB1X	650 mm / 25,6 in	500 mm / 19,7 in	150 mm / 5,9 in	90 mm / 3,5 in
i-DxxxB1V	800 mm / 31,5 in	600 mm / 23,6 in	154 mm / 6,1 in	90 mm / 3,5 in
i-DxxxC1R	355 mm / 14,0 in	305 mm / 12,0 in	128 mm / 5,0 in	75mm / 3,0 in
i-DxxxC1L	550 mm / 21,7 in	420 mm / 16,5 in	140 mm / 5,5 in	80 mm / 3,1 in
i-DxxxC1X	650 mm / 25,6 in	500 mm / 19,7 in	150 mm / 5,9 in	90 mm / 3,5 in

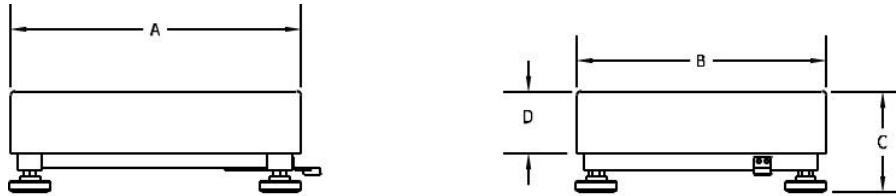
*Para fines de nivelación, los pies pueden extenderse hasta 15 mm adicionales.

CONFORMIDAD

El cumplimiento a las siguientes normas lo indica las marcas que se presente a continuación. Estas marcas están en el producto.

Marca	Estándar
	Este producto cumple con las normas estandarizadas vigentes de las Directivas de la UE 2011/65/EU (RoHS). La Declaración de Conformidad con la normativa comunitaria está disponible en línea, en www.ohaus.com/ce .
	Este producto cumple con las normativas legales aplicables del Reglamento sobre Restricciones a la Utilización de Determinadas Sustancias Peligrosas en Equipos Eléctricos y Electrónicos de 2012. La declaración de conformidad del Reino Unido está disponible online en www.ohaus.com/uk-declarations
	Este producto cumple con la Directiva de la UE 2012/19/EU (WEEE). Elimine este producto de acuerdo con los reglamentos locales en los puntos de recolección que se ponen a disposición para los equipos eléctricos y electrónicos. Para más instrucciones de eliminación en Europa, consulte www.ohaus.com/weee .

Registro de ISO 9001

El sistema de gestión que rige la producción de este producto está certificado por la norma ISO 9001.

ACCESORIOS

TABLA 4. ACCESORIOS

Número de pieza	Descripción
30616409	Juego de ruedas, serie Defender SST
30372146	Juego de ruedas, serie Defender CS
30696595	Conjunto de columna 330mm SST i-D33
30696596	Conjunto de columna 680mm SST i-D33
30696597	Conjunto de columna 330mm CS i-D33
30696598	Conjunto de columna 680mm CS i-D33
30696599	Conjunto de columna 980mm CS i-D33
30696600	Kit de montaje frontal i-D33

GARANTÍA LIMITADA

Los productos OHAUS están garantizados contra defectos en los materiales y mano de obra desde la fecha de entrega y hasta que termine el período de garantía. Durante el período de garantía, OHAUS reparará, o si procede, reemplazará sin coste alguno cualquier componente o componentes que resulten ser defectuosos, siempre y cuando se devuelva el producto a OHAUS con los gastos de envío pagados por adelantado. Esta garantía no se aplica si el producto ha sido dañado por accidente o mal uso, expuesto a materiales radioactivos o corrosivos, si algún objeto extraño penetra en el interior del producto, o como resultado de haber sido modificado o prestado servicio por personas ajenas a OHAUS. Además del envío apropiado de la tarjeta de garantía, el periodo de garantía comienza en la fecha del envío al distribuidor autorizado. No existe ninguna otra garantía expresa o implícita ofrecida por OHAUS Corporation. OHAUS Corporation no puede ser demandada por daños consecuentes.

Ya que las legislaciones de garantías difieren de estado a estado y de país a país, para obtener más información póngase en contacto con su representante local de OHAUS.

INTRODUCTION

Le présent manuel couvre les instructions d'installation et d'entretien de la série de base Defender™. Veuillez lire entièrement le présent manuel avant de procéder à l'installation et à l'opération.

PRÉCAUTIONS DE SÉCURITÉ

Pour une opération sécurisée du présent produit, veuillez respecter les précautions suivantes:

- Opérer la base uniquement sous des conditions ambiantes spécifiées dans les présentes instructions.
- S'assurer que le câble de la cellule de charge ne constitue pas un risque d'obstruction ou de trébuchement.
- Ne pas opérer la base dans des environnements dangereux ou dans des emplacements instables.
- Évitez de laisser des charges tomber sur la base.
- Ne pas soulever la base avec la cadre supérieur, toujours soulever à partir du cadre inférieur lors du déplacement de la base.
- Le service doit uniquement être effectué par le personnel autorisé.



INSTALLATION

Désemballage

Déemballer et inspecter le produit afin de s'assurer que tous les composants sont disponibles. L'emballage comprend les éléments suivants:

- Base de séries Defender™
- Plateau de pesée
- Manuel d'instruction

Lors de l'achat d'une balance de séries Defender, l'emballage comprend également:

- Indicateur
- Kit Colonne (Kit de montage frontal)

ASSEMBLAGE

Plateau de pesée

Retirer les entretoises d'expédition et placer le plateau de pesée en toute sécurité au dessus des coussinets de charge en caoutchouc au niveau du cadre supérieur de la base.

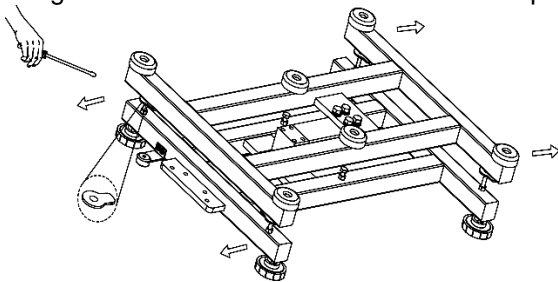

Note: Non inclus avec certains modèles.

Connexions de câblage

Lors de la connexion de la base à un indicateur OHAUS équipé avec le connecteur circulaire correspondant, pousser le connecteur de base sur le connecteur d'indicateur et tourner la bague de verrouillage dans le sens horaire pour le verrouiller en place.

Lors de la connexion de la base à un indicateur ne possédant pas de connecteur correspondant, installer l'adaptateur du câble de la cellule de charge optionnelle (P/N 30429931 vendu séparément) à l'indicateur en utilisant les codes de câblage du tableau 1. Monter ensuite le câble de la cellule de charge sur l'adaptateur du câble.

Remarque: En tant que méthode de câblage alternatif, couper le connecter, dénuder les câbles et les monter sur l'indicateur en utilisant les codes de câblage du tableau 1.

L'accessoire du câble d'extension (P/N: 30429931) ne pourrait pas être utilisé si la balance sera utilisée de manière légale pour le commerce ou pour une application légalement contrôlée parce qu'il n'y a pas de disposition pour sceller la connexion entre l'indicateur et la plateforme.

Si votre base ne prend pas en charge EasyConnect™, veuillez vous référer au manuel de l'indicateur pour savoir comment connecter le connecteur du capteur de charge.

TABLEAU 1. CONNEXION DE LA CELLULE DE CHARGE

Type1. Pour le modèle i-DxxxB1R, base i-DxxxB1L

FONCTION	COULEUR DU FIL
+ Excitation	Rouge
- Excitation	Noir
+ Signal	Bleu
- Signal	Blanc
Cadre	Transparent

Type1. Pour le modèle i-DxxxB1X, base i-DxxxB1V

FONCTION	COULEUR DU FIL
+ Excitation	Rouge
- Excitation	Noir
+ Signal	Vert
- Signal	Blanc
+ Capte	Bleu
- Capte	Jaune
Cadre	Transparent

Type2. Pour le modèle base i-DxxxC1x

FONCTION	COULEUR DU FIL
+ Excitation	Vert
- Excitation	Noir
+ Signal	Rouge
- Signal	Blanc
+ Capte	Bleu
- Capte	Marron
Cadre	Jaune

Sélection de la position

Pour assurer la fiabilité, une bonne performance et la sécurité, positionner et opérer la base sur une surface nivelée et stable. Évitez les positions avec les changements de température rapide ou une grande poussière, les courants d'air, les vibrations, les champs électromagnétiques ou la chaleur.

Niveler la base en réglant les quatre pieds de nivellement jusqu'à ce que la bulle dans l'indicateur de niveau soit centrée. Une clé pourrait être nécessaire pour serrer l'écrou de verrouillage au dessus de chaque pied de nivellement. Lorsque la base est nivelée, resserrer les écrous de verrouillage contre la base pour serrer chaque pied en place.

Remarque: S'assurer que la base est nivelée à chaque fois que la position est changée.



CORRECT



INCORRECT

ENTRETIEN

Nettoyage

Les composants de base doivent être maintenus propres et libres de l'accumulation des matériels.

- Un tissu mouillé avec de l'eau et un détergent doux pourraient être utilisés pour nettoyer les surfaces externes - Ne jamais utiliser les acides, les alcalis, les solvants solides ou les matériels abrasifs.

Pour maintenir l'intégrité de la surface, ne pas laisser les débris rester sur la surface du cadre de base en acier inoxydable ou peint.

- Retirer le plateau et utiliser de l'eau fraîche pour nettoyer la surface du cadre de base de tout débris. Sécher la base avec un tissu propre ou laisser sécher à l'air avant de remplacer le plateau. Répéter cette opération quotidiennement pour un meilleur entretien.

Dépannage

En dehors des composants d'installation et des réglages de nivellement, la base de séries Defender ne nécessite pas d'autres réglages lorsqu'expédiés de l'entreprise.

Les difficultés opérationnelles auxquelles vous pourrez faire face peuvent avoir les causes suivantes:

- Connexions de câblage incorrect ou desserré.
- Impossible de retirer les entretoises d'expédition.
- Obstructions du cadre de base.
- Environnements de base.
- Calibrage incorrecte ou réglage de l'indicateur.

Si La section de dépannage ne résout ou ne décrit pas votre problème; contacter votre agent de service autorisé OHAUS Pour le service d'assistance ou le support technique aux États-Unis, appeler gratuitement le 1-800-526-0659 entre 8:00 et 17:00 H EST. Un spécialiste de produit OHAUS sera disponible pour vous fournir une assistance. Hors des USA, veuillez visiter notre site web à l'adresse www.ohaus.com afin de localiser le bureau OHAUS le plus proche.

DONNÉES TECHNIQUES

Caractéristiques techniques

Les données techniques sont valides sous les conditions ambiantes suivantes:

Température de fonctionnement: -10°C à +40 °C (14 °F à 104 °F)

Humidité relative: humidité relative maximale de 80 % pour des températures allant jusqu'à 31 °C diminuant linéairement jusqu'à 50 % d'humidité relative à 40 °C.

Altitude: Jusqu'à 2 000m

Degré de pollution : 2

Remarque: Tous les modèles pourraient ne pas être disponibles dans votre zone. Veuillez vérifier avec votre représentant local OHAUS.

TABLEAU 2.1 SPÉCIFICATIONS

Modèle	i-D15B1R	i-D30B1R	i-D60B1R	i-D60B1L	i-D150B1L	i-D150B1X	i-D300B1X	i-D300B1V	i-D600B1V
Capacité	15 kg	30 kg	60 kg	60 kg	150 kg	150 kg	300 kg	300 kg	600 kg
Résolution validée	OIML 3000e								
Capacité de surcharge sécurisée	150 % de la capacité								
Dimensions du plateau	305 x 355 mm			420 x 550 mm		500 x 650 mm		600 x 800 mm	
Matériaux de la base	Plateforme en acier inoxydable avec cadre en acier carboné et pieds de nivellement en caoutchouc								
Cellule de charge Capacité	30 kg	50 kg	100 kg	100 kg	250 kg	250 kg	500 kg	500 kg	750 kg
Cellule de charge Câble	2 m L x 4 fils					3 m L x 6 fils			
Cellule de charge Tapez	mono point aluminium 350 Ohm								
Cellule de charge Excitation	5-12 V courant alternatif ou continu								
Cellule de charge Sortie nominale	2 mV/V								
Poids net	7 kg / 15,9 lb			13 kg / 28,8 lb		23 kg / 51,2 lb		41 kg / 90,6 lb	
Poids à l'expédition	10 kg / 22,5 lb			17 kg / 37,8 lb		27 kg / 58,9 lb		45 kg / 99,4 lb	
Cellule de charge Protection	IP65								

TABLEAU 2.2 SPÉCIFICATIONS

Modèle	i-D15C1R	i-D30C1R	i-D60C1R	i-D60C1L	i-D150C1L	i-D150C1X	i-D300C1X
Capacité	15 kg	30 kg	60 kg	60 kg	150 kg	150 kg	300 kg
Résolution validée	OIML 3000e						
Capacité de surcharge sécurisée	150 % de la capacité						
Dimensions du plateau	305 x 355 mm			420 x 550 mm		500 x 650 mm	
Matériaux de la base	Plateforme en acier inoxydable avec cadre en acier inoxydable et pieds de nivellement en caoutchouc						
Cellule de charge Capacité	30 kg	50 kg	100 kg	100 kg	300 kg	300 kg	500 kg
Cellule de charge Câble	2 m L x 6 fils						
Cellule de charge Tapez	mono point acier inoxydable 350 Ohm						
Cellule de charge Excitation	5-15 V courant alternatif ou continu						
Cellule de charge Sortie nominale	2 mV/V						
Poids net	8 kg / 17,1 lb			14 kg / 30,7 lb		27 kg / 58,5 lb	
Poids à l'expédition	11 kg / 23,7 lb			18 kg / 39,6 lb		30 kg / 66,2 lb	
Cellule de charge Protection	IP67						

TABLEAU 2.3 SPÉCIFICATIONS

Modèle	i-D15B1R	i-D30B1R	i-D75B1R	i-D75B1L	i-D150B1L	i-D150B1X	i-D300B1X	i-D300B1V	i-D600B1V
Capacité	30 lb / 15 kg	60 lb / 30 kg	150 lb / 75 kg	150 lb / 75 kg	300 lb / 150 kg	300 lb / 150 kg	600 lb / 300 kg	600 lb / 300 kg	1 200 lb / 600 kg
Résolution validée	NTEP et Mesures Canada 3000e								
Capacité de surcharge sécurisée	150 % de la capacité								
Dimensions du plateau	305 x 355 mm			420 x 550 mm		500 x 650 mm		600 x 800 mm	
Matériaux de la base	Plateforme en acier inoxydable avec cadre en acier carboné et pieds de nivellement en caoutchouc								
Cellule de charge Capacité	30 kg	50 kg	100 kg	100 kg	250 kg	250 kg	500 kg	500 kg	750 kg
Cellule de charge Câble	2 m L x 4 fils					3 m L x 6 fils			
Cellule de charge Tapez	mono point aluminium 350 Ohm								
Cellule de charge Excitation	5-12 V courant alternatif ou continu								
Cellule de charge Sortie nominale	2 mV/V								
Poids net	7 kg / 15,9 lb			13 kg / 28,8 lb		23 kg / 51,2 lb		41 kg / 90,6 lb	
Poids à l'expédition	10 kg / 22,5 lb			17 kg / 37,8 lb		27 kg / 58,9 lb		45 kg / 99,4 lb	
Cellule de charge Protection	IP65								

TABLEAU 2.4 SPÉCIFICATIONS

Modèle	i-D15C1R	i-D30C1R	i-D75C1R	i-D75C1L	i-D150C1L	i-D150C1X	i-D300C1X
Capacité	30 lb / 15 kg	60 lb / 30 kg	150 lb / 75 kg	150 lb / 75 kg	300 lb / 150 kg	300 lb / 150 kg	600 lb / 300 kg
Résolution validée	NTEP et Mesures Canada 3000e						
Capacité de surcharge sécurisée	150 % de la capacité						
Dimensions du plateau	305 x 355 mm			420 x 550 mm		500 x 650 mm	
Matériaux de la base	Plateforme en acier inoxydable avec cadre en acier inoxydable et pieds de nivellement en caoutchouc						
Cellule de charge Capacité	30 kg	50 kg	100 kg	100 kg	300 kg	300 kg	500 kg
Cellule de charge Câble	2 m L x 6 fils						
Cellule de charge Tapez	mono point acier inoxydable 350 Ohm						
Cellule de charge Excitation	5-15 V courant alternatif ou continu						
Cellule de charge Sortie nominale	2 mV/V						
Poids net	8 kg / 17,1 lb			14 kg / 30,7 lb		27 kg / 58,5 lb	
Poids à l'expédition	11 kg / 23,7 lb			18 kg / 39,6 lb		30 kg / 66,2 lb	
Cellule de charge Protection	IP67						

SCHEMAS

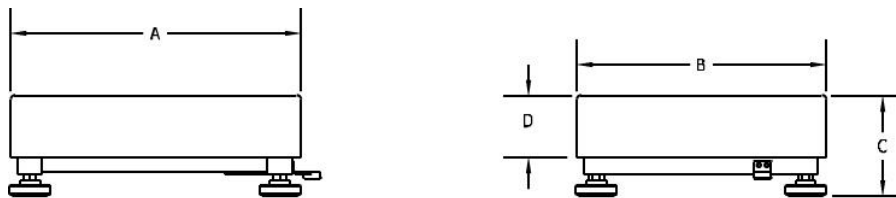

Figure 1. Schéma de dimension de base Defender



TABLEAU 3. DIMENSIONS

Base	A	B	C	D
	Profondeur du plateau	Largeur du plateau	Hauteur du plateau à la surface de la table	Hauteur du plateau
i-DxxxB1R	355 mm / 14,0 in	305 mm / 12,0 in	128 mm / 5,3 in	75 mm / 3,0 in
i-DxxxB1L	550 mm / 21,7 in	420 mm / 16,5 in	140 mm / 5,5 in	80 mm / 3,1 in
i-DxxxB1X	650 mm / 25,6 in	500 mm / 19,7 in	150 mm / 5,9 in	90 mm / 3,5 in
i-DxxxB1V	800 mm / 31,5 in	600 mm / 23,6 in	154 mm / 6,1 in	90 mm / 3,5 in
i-DxxxC1R	355 mm / 14,0 in	305 mm / 12,0 in	128 mm / 5,0 in	75 mm / 3,0 in
i-DxxxC1L	550 mm / 21,7 in	420 mm / 16,5 in	140 mm / 5,5 in	80 mm / 3,1 in
i-DxxxC1X	650 mm / 25,6 in	500 mm / 19,7 in	150 mm / 5,9 in	90 mm / 3,5 in

*Pour la mise à niveau, les pieds peuvent être allongés de 15 mm supplémentaires.

CONFORMITÉ

La conformité aux normes suivantes est indiquée par le symbole correspondant sur le produit.

Symbole	Norme
	Ce produit est conforme aux normes harmonisées correspondantes des Directives de l'UE 2011/65/EU (RoHS). La Déclaration de Conformité de l'UE est disponible en ligne sur www.ohaus.com/ce .
	Ce produit est conforme aux normes légales applicables du Règlement de 2012 sur la restriction de l'utilisation de certaines substances dangereuses dans les équipements électriques et électroniques. La Déclaration de conformité du Royaume-Uni est disponible en ligne sur www.ohaus.com/uk-declarations .
	Ce produit est conforme aux Directives de l'UE 2012/19/EU (WEEE). Merci de disposer de ce produit conformément à la réglementation locale au point de collecte spécifié pour les équipements électriques et électroniques. Pour obtenir des instructions d'élimination en Europe, consultez www.ohaus.com/weee .

Enregistrement ISO 9001

Le système de gestion régissant la production de ce produit est certifié ISO 9001.

ACCESSOIRES

TABLEAU 4. ACCESSOIRES

Numéro de pièce	Description
30616409	Kit de roues Defender Series SST
30372146	Kit de roues Defender Series CS
30696595	Assemblage de colonne 330 mm SST i-D33
30696596	Assemblage de colonne 680 mm SST i-D33
30696597	Assemblage de colonne 330 mm CS i-D33
30696598	Assemblage de colonne 680 mm CS i-D33
30696599	Assemblage de colonne 980 mm CS i-D33
30696600	Kit de montage frontal i-D33

GARANTIE LIMITÉE

Les produits OHAUS sont garantis contre les défaillances dans les matériels et la fabrication à partir de la date de livraison jusqu'à la couverture entière de la période de garantie. Pendant la période de garantie, OHAUS réparera gratuitement, selon son appréciation ou remplacera tous les composants défectueux, à condition que le produit soit retourné à OHAUS et le fret prépayé. La présente garantie devient nulle si le produit est endommagé par accident ou par mauvaise utilisation, est exposé aux matériels radioactifs ou corrosifs, comporte des corps étrangers ou suite à une modification ou une réparation par des personnes non autorisées. Outre le renvoi de la carte d'enregistrement de garantie, la période de garantie commence à la date d'expédition au revendeur autorisé. Aucune autre garantie expresse ou implicite n'est offerte par OHAUS Corporation. OHAUS Corporation décline sa responsabilité pour des dommages consécutifs.

Etant donné que la législation de garantie varie selon les états et les pays, veuillez contacter OHAUS ou votre distributeur local OHAUS pour des informations supplémentaires.



OHAUS Corporation
7 Campus Drive
Suite 310
Parsippany, NJ 07054, USA
Tel: (973) 377-9000
Fax: (973) 944-7177

With offices worldwide / Con oficinas en todo el mundo / Avec des bureaux partout dans le monde /
Mit Büros weltweit / Con uffici in tutto il mondo / Com escritórios em todo o mundo / Med kontor över hela världen /
Met vestigingen wereldwijd / Med kontorer over hele verden / Biura na całym świecie / S kancelářemi po celém
světě / Irodákkal világszerte
www.ohaus.com



P/N 30708958 A © 2021 OHAUS Corporation, all rights reserved / todos los derechos reservados /
tous droits réservés / alle Rechte vorbehalten / tutti i diritti riservati / todos os direitos reservados / Alla rättigheter
förbehållna / alle rechten voorbehouden / alle rettigheder forbeholdes / wszelkie prawa zastrzeżone / všechna
práva vyhrazena / Minden jog fenntartva