

DC16

CANISTER LOAD CELL



**Diamond
DC16**

Stainless Steel, Washdown Safe, Reliable Canister Load Cells from Totalcomp

- ✓ *Stainless steel construction.*
- ✓ *Washdown safe.*
- ✓ *Easy installation.*
- ✓ *Interchangeable with HBM C16.*
- ✓ *Reliable performance.*
- ✓ *Includes 12m 6 cond. cable.*



Totalcomp[®] Scales & Components

99 Reagent Lane • Fair Lawn, New Jersey 07410

Fax: 201-797-2287 • Toll Free Fax: 888-797-2288 • Phone: 201-797-2718 • Toll Free Phone: 800-631-0347

Email: sales@totalcomp.com • Website: www.totalcomp.com

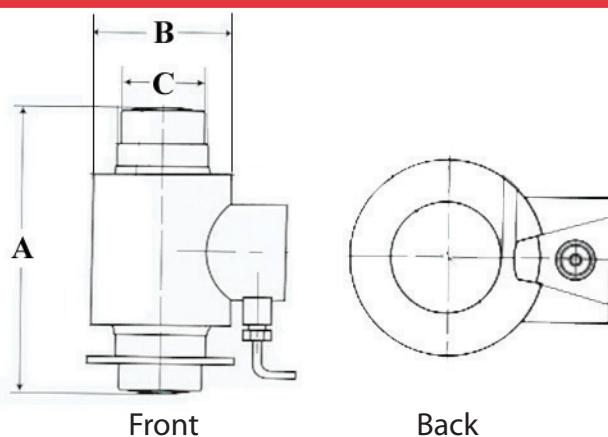

DC16

DIAMOND DC16 CANISTER LOAD CELL

The *Diamond* DC16 Canister Load Cell are interchangeable with HBM C16. They are constructed from Stainless Steel for washability and protection from harsh environments.

Part Number	Capacity	Weight	A	B	C
DC16-10t	10,000 kg	6 lb	5.12	3.00	1.73
DC16-15t	15,000 kg	6 lb	5.12	3.00	1.73
DC16-20t	20,000 kg	6 lb	8.27	3.00	1.73
DC16-30t	30,000 kg	6 lb	5.91	3.00	1.73
DC16-40t	40,000 kg	8 lb	5.91	3.00	1.73
DC16-50t	50,000 kg	8 lb	8.27	3.00	1.73
DC16-60t	60,000 kg	10 lb	8.27	3.00	1.73
DC16-100t	100,000 kg	30 lb	10.24	3.74	2.52

Performance

Full Scale Output

2.00 mV/V

Combined Error

±0.03% FSO

Nonlinearity

±0.02%

Hysteresis

±0.02%

Creep

±0.02% FS in 1 hour

Non-Repeatability

±0.01% FSO

Zero Balance

±1.0% FSO

Overload Safe

150% FSO

Overload Ultimate

300% FSO

Electrical

Bridge Resistance

Input 700 ohms

Output 700 ohms

Excitation Voltage

5VDC (18VDC Max)

Insulation Resistance

5KM ohms @ 50VDC

Temperature

Compensated Range

-10°C to +40°C

Temperature Operating Range

-40°C to +80°C

Effect on Zero Balance

0.029% FS/10°C

Effect on FS Output

0.017% FS/10°C

Mechanical

Material

Stainless Steel

Sealing

IP68

Wiring

Cable Length & Type

12m, 6 conductor

Cable Color Code

+ Excitation.....Green

- Excitation.....Black

+ Sense.....Yellow

- Sense.....Blue

+ Output.....White

- Output.....Red

Shield.....Bare

TOTALCOMP LIMITED WARRANTY

Totalcomp warrants this product to be free of defects in materials and/or workmanship and suitable for the purpose(s) intended as outlined on this sheet. This warranty is effective and shall cover the purchaser for one year from the date of shipment from our plant. If this product is found to be defective by our inspection in accordance with the above listed criteria, we will replace or repair it at our expense. For warranty service, please obtain a return authorization number from us and return the item, shipping prepaid, with a written description of the problem. We will respond promptly with the results of our evaluation.



Totalcomp[®]

Scales & Components

99 Reagent Lane

Fair Lawn, NJ 07410

Fax (201) 797-2287

Toll Free Fax (888) 797-2288

Phone (201) 797-2718

Toll Free Phone (800) 631-0347

Email sales@totalcomp.com

Website www.totalcomp.com