

S29 Series



S29 Series Bench Scale

- ✓ 25mm LCD display with LED back backlight
- ✓ Selectable weighing unit (kg/lb)
- ✓ Stainless steel housing, SST pan
- ✓ Battery provide up to 70 hours of continuous use (without backlight)
- ✓ Breathable knob design
- ✓ IP67 rated protection against low pressure of water



Totalcomp[®] Scales & Components

99 Reagent Lane • Fair Lawn, New Jersey 07410

Fax: 201-797-2287 • Toll Free Fax: 888-797-2288 • Phone: 201-797-2718 • Toll Free Phone: 800-631-0347

Email: sales@totalcomp.com • Website: www.totalcomp.com

SPECIFICATIONS

S29

S29 Washdown Bench Scale

Stainless steel housing with steel case, locks out water, dust and dirt. Portable.

Washdown with breathable knob design. Designed to withstand a variety of harsh conditions found in commercial and industrial facilities (tight knob for complete seal).

Large 25mm LCD display with white LED backlight make this scale easy to read. Keys for ON/OFF, Tare, ZERO. Indicators for Zero, Stable, Net, Battery, kg, lb, charging LED light. Adjustable feet and front bubbling level makes it easy to level the scale. 6V/3.2Ah rechargeable battery included. Battery provides up to 70 hours of continuous use (without backlight). Adapter included.

9.5"W x 11.75"D x 5"H. Platform: 7.5" x 9.0"

NTEP Certificate Number: 15-053

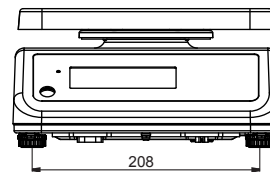
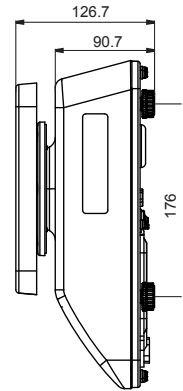
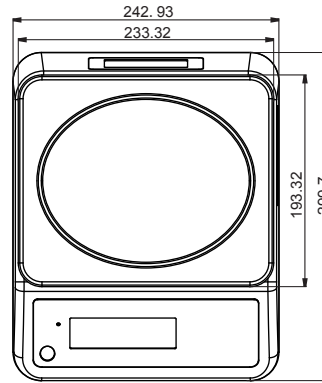

Dimension(mm)

SPECIFICATION

Model	S29-6 lb	S29-12 lb	S29-30 lb	S29-60 lb
Capacity	6 x 0.001 lb	12 x 0.002 lb	30 x 0.005 lb	60 x 0.01 lb
External Resolution	3000/6000			
Display	1.0 In LCD display with White back light			
Dimensions	9.05" x 11.8" x 7.5"			
Keypad	Three keys			
Operate Temperature	32°F - 104°F			
Power	Adaptor 12V/800mA, Battery 6 V/3.4 AH			
Internal Counts	Up to 60000			
Weight	9.25 lb			

*Non NTEP

TOTALCOMP LIMITED WARRANTY

Totalcomp warrants this product to be free of defects in materials and/or workmanship and suitable for the purpose(s) intended as outlined on this sheet. This warranty is effective and shall cover the purchaser for one year from the date of shipment from our plant. If this product is found to be defective by our inspection in accordance with the above listed criteria, we will replace or repair it at our expense. For warranty service, please obtain a return authorization number from us and return the item, shipping prepaid, with a written description of the problem. We will respond promptly with the results of our evaluation.



Totalcomp[®]

Scales & Components

99 Reagent Lane
 Fair Lawn, NJ 07410
 Fax (201) 797-2287
 Toll Free Fax (888) 797-2288
 Phone (201) 797-2718
 Toll Free Phone (800) 631-0347
 Email sales@totalcomp.com
 Website www.totalcomp.com