

TEI

Indicator

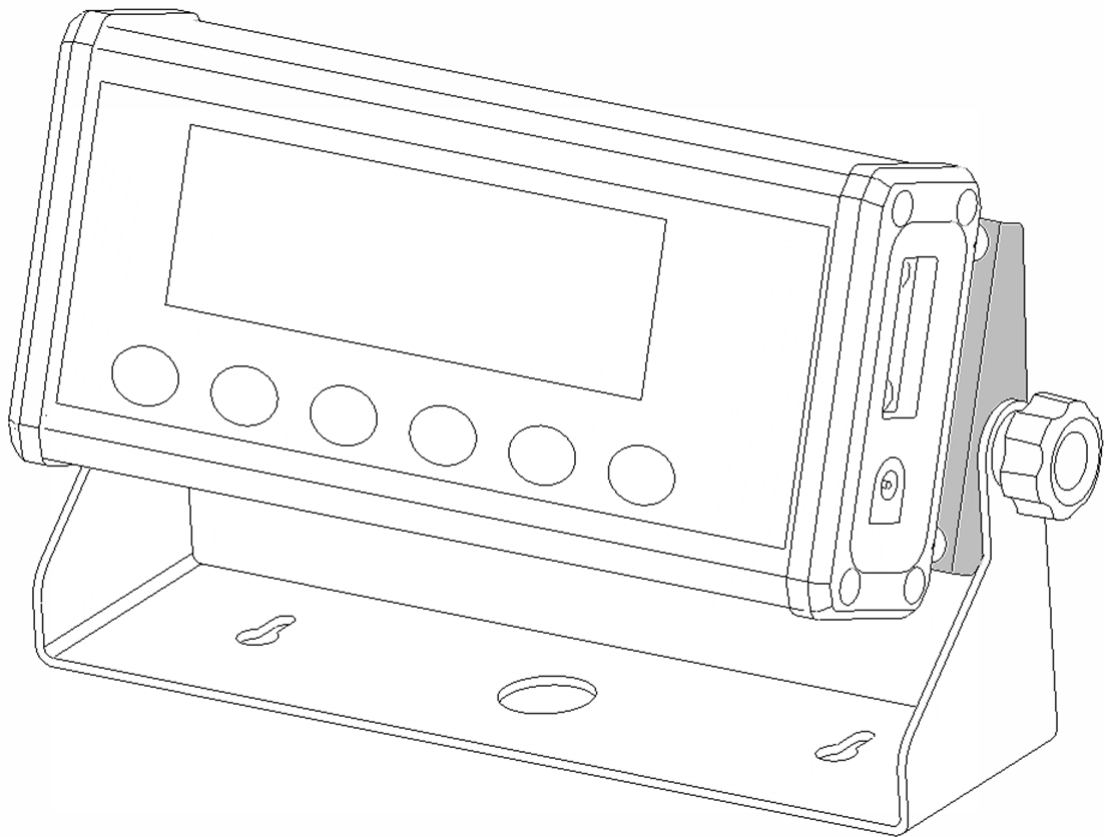

Operation & Service

Manual

V4.12

Contents Subject to Change without Notice

CONTENT

1. Specification	2
2. Faceplate.....	9
3. Summary of Key function	10
4. Operation Menu Structure	12
5. Normal Weighing mode.....	24
6. Count Weighing Mode.....	27
7. Percent Weighing Mode	29
8. BMI Working Mode	30
9. HOLD Function	31
10. Data Compare Function	32
11. Accumulation	33
12. Calibration.....	34
13. Weight Fine-tune	37
14. View ADC output Code.....	37
15. View or Calibrate Power Voltage	38
16. View or Set Time.....	38
17. View or Set Date	38
18. View Firmware Version.....	38
19. Display Test	39
20. Keyboard and Buzzer Test.....	39
21. Serial Port1/2 (COM1/2) Receiving Test	39
22. Serial Port1/2(COM1/2) Transmitting Test.....	39
23. Details about Serial Communication.....	40
24. Bluetooth Configuration	47
26. Meaning of Some Symbols and Troubleshooting	52
27. Display Character	55
28. Packing List	56
29. Version History	57

EHI-E1 Indicator Operation Manual

Thank you for purchasing the EHI-E1 indicator. Please read all operating instructions carefully before use and keep the following points in mind:

- * Avoid lengthy exposure to extreme heat or cold, your scale works best when operated at normal room temperature. Always allow the scale to acclimate to a normal room temperature before use
- * Always use a proper power supply and well connected load cell.
- * Allow sufficient warm up time. Turn the scale on and wait for a few minutes if possible, to give the internal components a chance to stabilize before weighing.
- * These electronic scales are precision instruments. Do not operate near an in-use cell phone, radio, computer or other electronic device. These devices emit RF and can cause unstable scale readings. If your scale ever performs poorly, try moving the scale to a different room or location.
- * Avoid using in condition of heavy vibration and airflow.
- * Read the weight reading in short time after loading. The output signature of load cell and electronic circuit may be little influenced after weighing for a long time.
- * **Some functions maybe disabled by manufacture before shipping, if you need these functions or don't want to use some other functions, please contact with manufacture in advance, because of this, some operations or faceplate maybe are a little bit different, and some description sections may be deleted.**

1. Specification

1.1 Housing, Outline and Bracket installation:

Note: in some not trade application, the seal may not be installed on housing.

1.1.1 DB9 used as load cell wires connector:

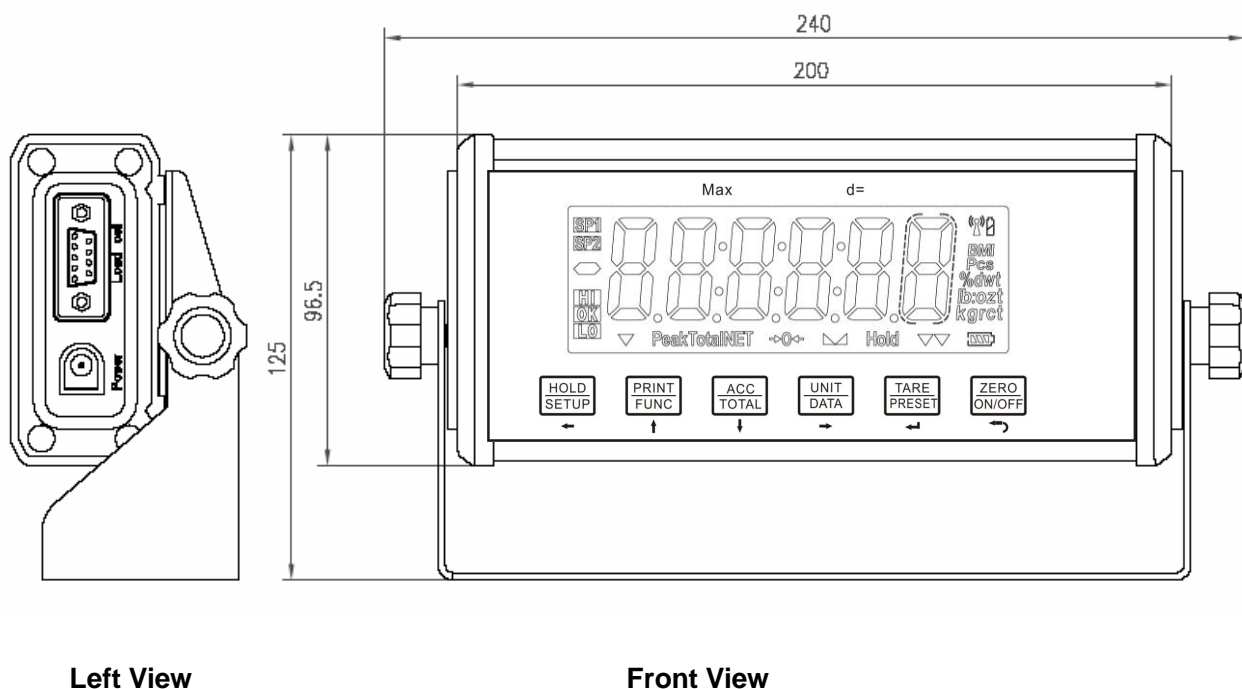

1.1.1 DB9 used as load cell wires connector (continuous):

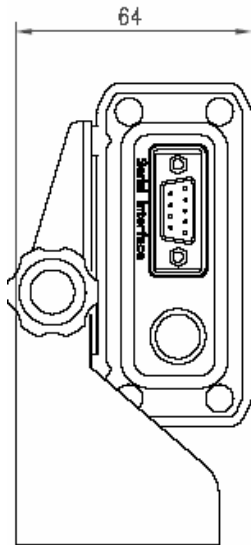

Right View

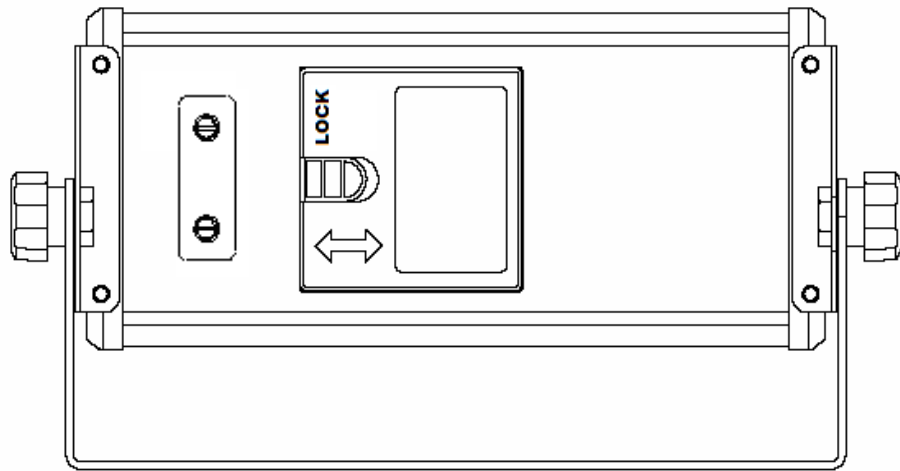

Back View

1.1.2 If a pigtail of 4/7-pin circle socket is used and go to indicator from side, the outline is similar as following shown:

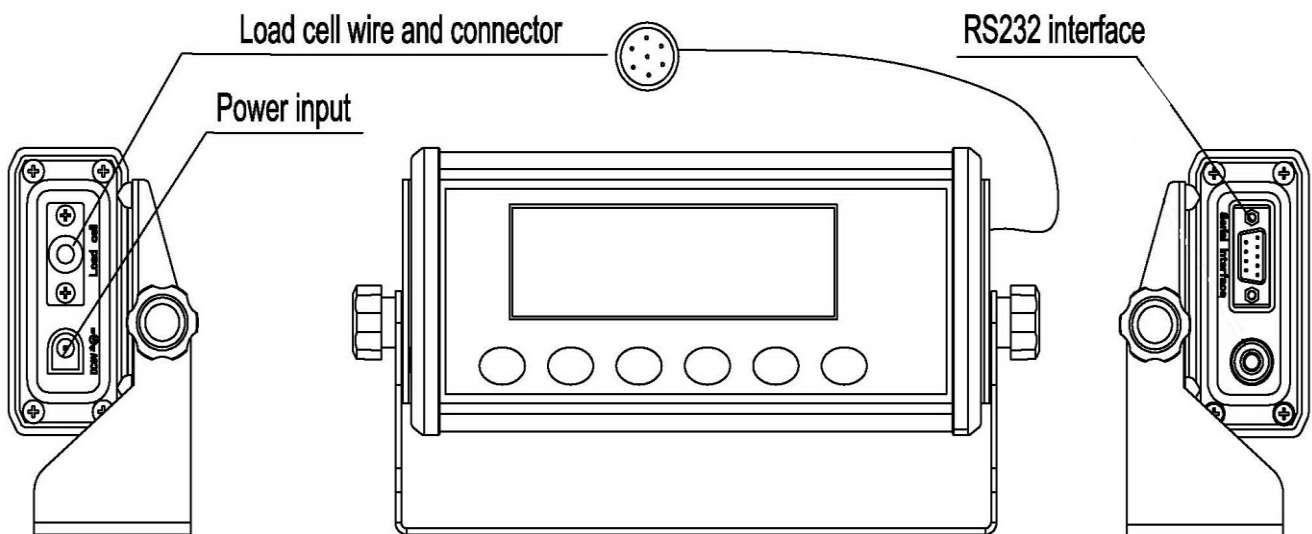

1.1.3 If a pigtail of 4/7-pin circle socket is used and go to indicator, from the bottom, the outline is similar as right fig. shown:

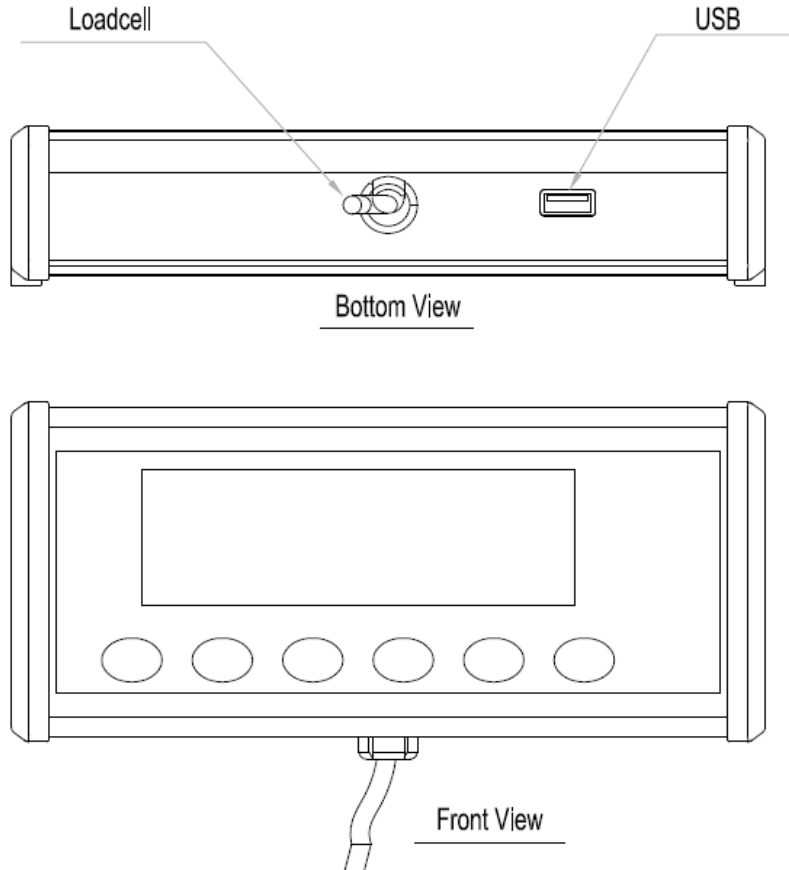

1.1.4 If a pigtail of 4/7-pin circle socket is used and load cell wires go to this indicator from the back side, the outline is similar as following fig. shown:

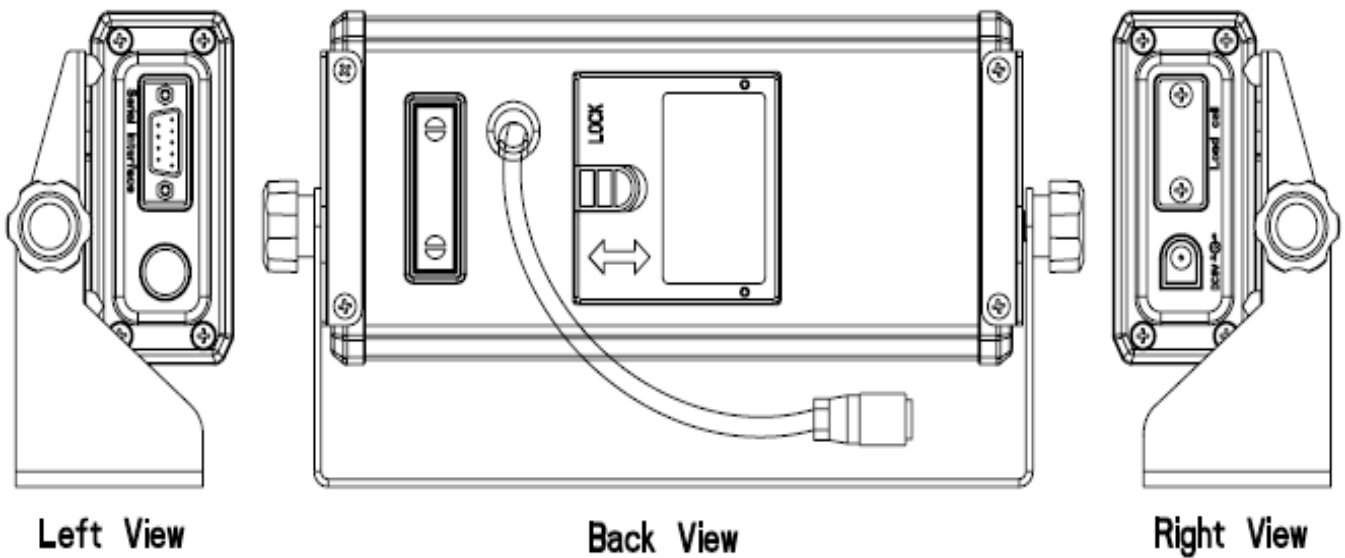

1.1.5 Indicator bracket installation:

1.1.5.1 According to following figure, use locknut to fasten part1 and part2 onto the bracket, and make sure part1 and part2 in correct direction.

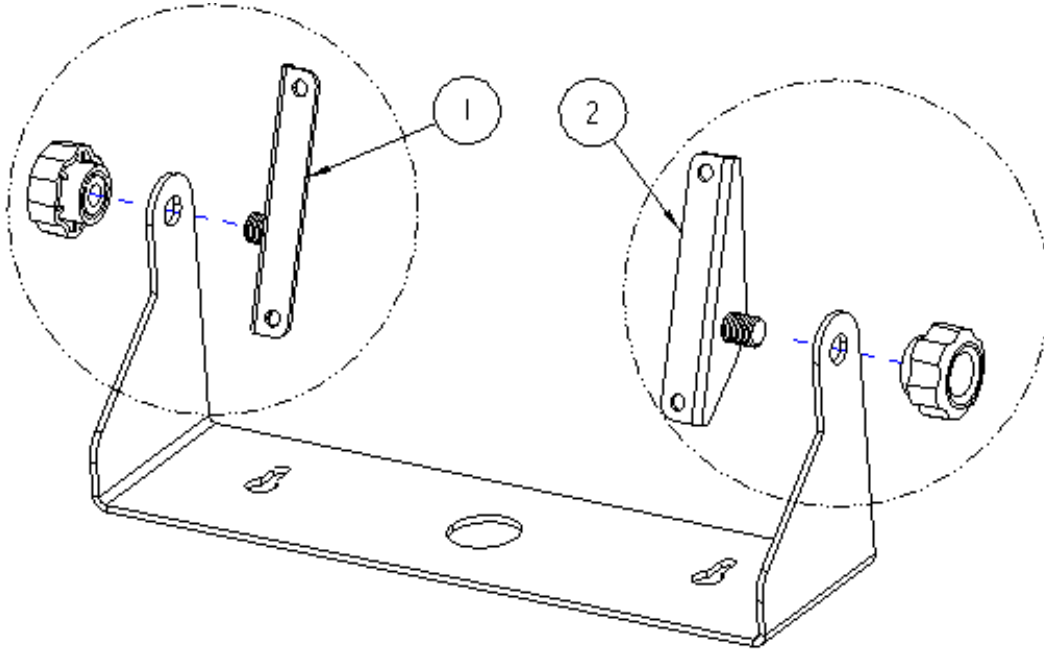

1.1.5.2 From the back side of rear side, fasten the indicator to the bracket by using four M4x6 screws.

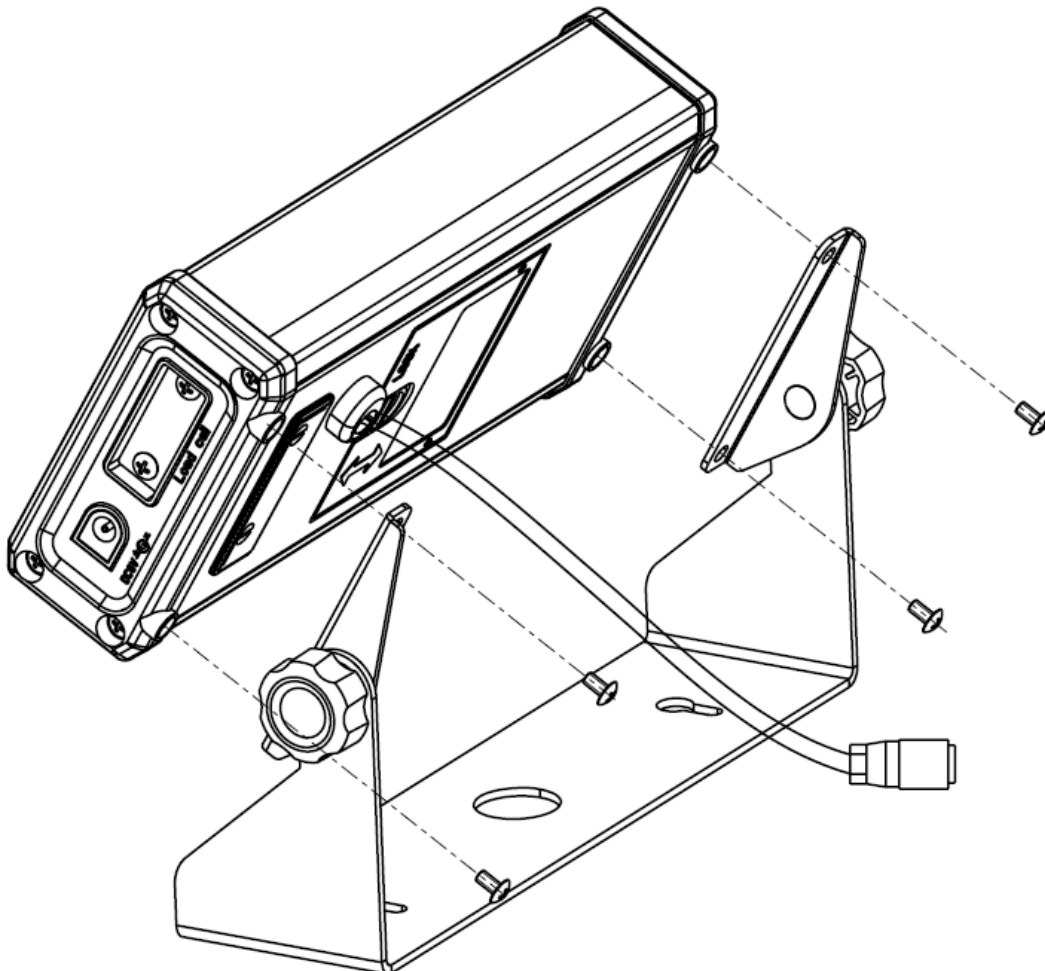

1.2 Power Supply:

- 1.2.1 4xAA size alkaline batteries: When the sign of battery is empty, this prompt you'd better to replace batteries; When "Lo.bAt" displayed, this prompt you should replace batteries immediately, otherwise, it will turn off automatically in 10s.
- 1.2.2 Optional 4xAA NIMH rechargeable batteries pack: when this battery is used, use AC adapter to power indicator and charge batteries.

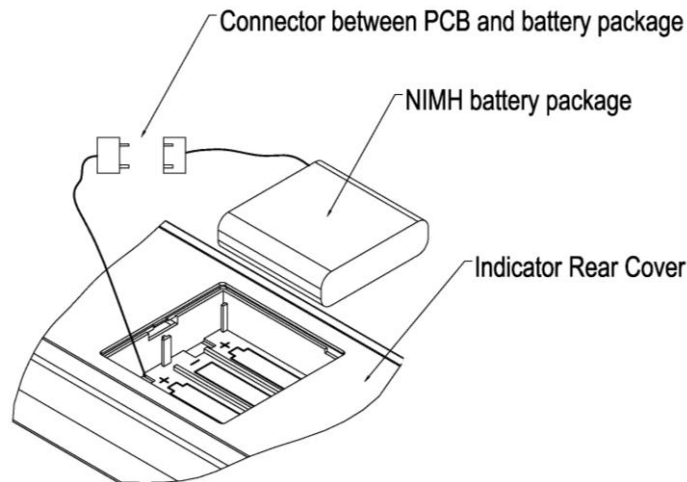

CAUTION:

Make sure the wires on the connector should be RED to RED (Battery+) and BLACK to BLACK (Battery-) !

1.2.3 AC Adapter: 6-9V_{DC}, $\geq 500\text{mA}$, central positive:

1.2.4 USB power supply if USB interface is installed



1.2.5 Work current: $\leq 15\text{mA}$ (with backlight off, no optional Bluetooth Module and no load cells)

$\leq 30\text{mA}$ (with backlight on, no optional Bluetooth Module and no load cells)

$\leq 50\text{mA}$ (with backlight on and one 350 load cell, no optional Bluetooth Module)

1.3 Display:

6-digit, 7-segment, 1"(25mm) LCDs with 16 annunciators and blue backlight

1.4 Keypad: 6 push buttons

1.5 Environment:

1.5.1 Working temperature: -10°C to 40°C

1.5.2 Storage temperature: -20°C to 70°C

1.5.3 Humidity: 10 to 90% RH without condensation

1.6 Load cell Excitation:

1.6.1 Voltage: 5Vdc

1.6.2 Max. Current: 60mA (can power 4-350 ohm bridge, take care the limitation when USB is power supply)

1.6.3 Signal connection: 4 or 6 lead with sense leads

1.6.4 Max Sensitivity: -3mV/V to $+3\text{mV/V}$

1.6.5 Load cell Wiring (only be active when corresponding hardware is installed):

1.6.5.1 9 holes socket used:

- Pin1:** Excitation +
- Pin6:** Sense +
- Pin4:** Excitation –
- Pin9:** Sense –
- Pin2:** Signal +
- Pin3:** Signal -
- Pin5:** Shield
- Pin7 & Pin8:** NC (no connection)

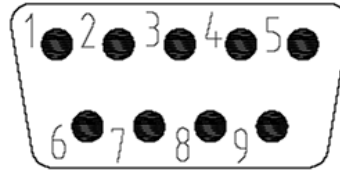
**1.6.5.2 7 holes socket used:**

- Pin1:** Excitation +
- Pin4:** Excitation –
- Pin2:** Sense +
- Pin5:** Sense –
- Pin3:** Signal +
- Pin6:** Signal -
- Pin7:** Shield

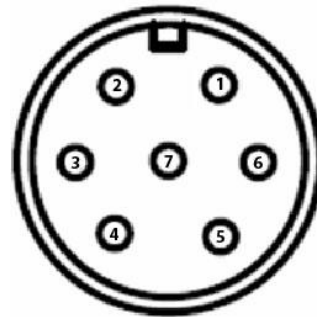
**1.6.5.3 4 holes socket used (if used) :**

- Pin1:** Excitation +
- Pin2:** Excitation –
- Pin3:** Signal -
- Pin4:** Signal +

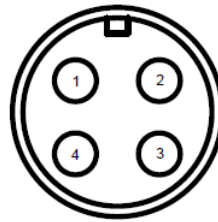

If other special connection is used, please refer the additional paper

1.7 Communication:

- 1.7.1 Serial port1: Full-duplex RS232
- 1.7.2 Serial port2: USB (Virtual RS232)
- 1.7.3 Optional Serial port3: Bluetooth
- 1.7.3 Baud Rate: Selectable: 1200-2400-4800-9600-19200-38400 bps
- 1.7.4 Data Output Format: 8N1, 7O1, 7E1, 7E2, 7O2
- 1.7.5 Protocol: programmable

1.8 Analog Circuit characters:

- 1.8.1 24-bit A/D converter
- 1.8.2 Conversion Speed: 10Hz or 80Hz selectable
- 1.8.3 Input range: -15mV to +15mV
- 1.8.4 Output code: 1mV input between S+ and S- of load cell connector will output about 100,000 raw Counts.
- 1.8.5 With Hardware low pass filter and two programmable digital low pass filters

1.9 Accuracy: ≤0.01%**1.10 Capacity and Division: Programmable**

- 1.10.1 Max display range: -999,999 to 999,999
- 1.10.2 Division number range for primary unit: 100-100,000
Division number range for second unit: 100-125,000
(Division number will be limited by REGULA setting)
- 1.10.3 Recommended Sensitivity: >1uV/ display division

1.11 Calibration Method:

- 1.11.1 Software calibration with long-term storage in EEPROM
- 1.11.2 Provides smooth curve fit through four points.
- 1.11.3 Calibration can be done under kg or lb weight unit with 10% -100%FS standard weight
- 1.11.4 Optional directly weight fine adjustment ($\pm 10\%$)
- 1.11.5 Optional Geographical Adjustment

1.12 Real Clock: optional built-in nonvolatile real time & date



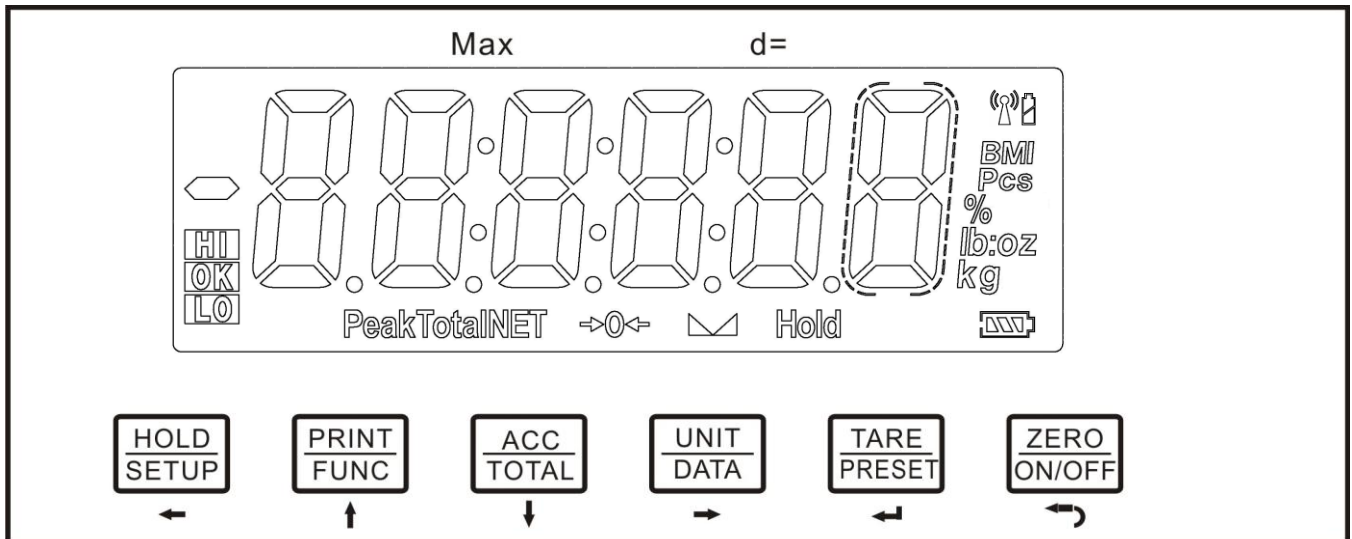

1.13 Other Main Function:

- 1.13.1 Programmable Initial or key Zero Range; automatic zero point tracking range;
- 1.13.2 Programmable pre-set tare weight
- 1.13.3 Programmable motion detection window
- 1.13.4 Programmable auto-power off time, backlight working mode
- 1.13.5 Programmable hold function: with peak weight holding, dynamic weighing
- 1.13.6 Available Check Weighing Mode; Parts Counting Mode; Percentage Working Mode
- 1.13.7 Available Measure Unit: kg, g, lb, oz, lb:oz, PCS, %,
- 1.13.8 Data Comparison and indicator of High, OK and Low is available in Weighing mode, Parts Counting mode and Percentage Working mode.
- 1.13.9 Battery voltage is low and charging indicator
- 1.13.10 Programmable what content will be output and when they are output on serial port.
- 1.13.11 Optional BMI function

2. Faceplate



Meaning of symbol on faceplate:

- 2.1  turn on when scale is stable
- 2.2  turn on when scale is at zero point and the gross weight is 0
- 2.3 **NET** turn on when net weight is displaying, and the tare weight is not 0; turn off when gross weight is displaying
- 2.4 **TOTAL** turn on when display data is total times or total of weight, pieces or percentage
- 2.5 **lb** turn on when measure unit is lb or lb:oz
- 2.6 **oz** turn on when measure unit is oz or lb:oz
- 2.7 **kg** turn on when measure unit is kg
- 2.8 **g** turn on when measure unit is g
- 2.9 **%** turn on when in percentage weighing mode, measure unit is %
- 2.10 **Pcs** turn on when in counting mode, measure unit is pieces
- 2.11 **PEAK** turn on when in working in HOLD mode and HOLD type is PEAK-HOLD
- 2.12 **HOLD** turn on and flashing/not flashing: working HOLD mode and displaying number is/isn't live
- 2.13 **BMI** turn on when working in BMI mode
- 2.14 **HI** turns on when data compare is enabled and current data (weight, pieces or percent) is over its upper setting limitation.
- 2.15 **OK** turns on when data compare is enabled and current data (weight, pieces or percent) is between its high limitation and low limitation
- 2.16 **LO** turn on when data compare is enabled and current data (weight, pieces or percent) is below its lower limitation
- 2.17  turn on when battery is used or charged
- 2.18  flash when local wireless module is installed and powered on before link, become steady on after linked with remote wireless device
- 2.19  turn on when remote wireless device is in battery low state

3. Summary of Key function

Key	Condition	Function
HOLD SETUP ←	Weighing/Counting/Percent, press down <3s	Enter or exit HOLD mode
	Weighing/Counting/Percent, press down > 3s	To enter setup mode
	Input data mode, press down >3s	to input decimal point
	Input data mode, press down <3s	Return to last sub-menu
	Menu selection mode	Return to last sub-menu
PRINT FUNC ↑	Weighing/Counting/Percent, press down <3s	Output data to serial communication port
	Weighing/Counting/Percent , press down > 3s	select working mode: weighing ,counting or percent
	Input data mode	The digit on flashed position add 1
	Menu selection mode	To last item of current menu
ACC TOTAL ↓	Weighing/Counting/Percent/BMI, press down <3s	ACCUMULATION function is enabled in configuration menu : To add up current weight/pieces/percentage to memory, display times and total of accumulation; in BMI working mode, to input height
	Weighing/Counting/Percent, press down >3s	ACCUMULATION function is enabled in configuration menu, To display times and total of accumulation
	Input data mode	the digit on flashed position subtract 1
	Menu selection mode	To Next item of current menu
UINT DATA →	Weighing mode, press down<3s	Change weighing units: kg->lb->lb:oz (not be available in some conditions)->kg
	Counting/Percent mode, press down < 3s	To enter getting piece weight or unit-percentage-weight mode (by way of sample or input directly).
	Weighing /Counting/Percent mode, press down> 3s	To input compare data (for weight , pieces or percentage) of high and low limitation
	Display date or time mode, press down >3s	To set current date or time

	Display voltage mode, press down >3s	To calibrate input voltage value
	Display ADC code	Select displaying code from no-filter, filter1, filter2
	Input data mode	Rotate the flashed position from left to right
TARE PRESET ←	Weighing/Counting/Percent , press down <3s	Tare function
	Weighing/Counting/Percent , press down > 3s	To input pre-set tare weight at selected weight unit
	input data mode or Menu selection mode	To confirm input data or current item selection, and go to next item of current menu, or next operation
	Display ADC code	Set or clear “tare” code
ZERO ON/OFF →	Power off mode	Power on
	Weighing/Counting/Percent, press down <3s	Zero function
	Weighing/Counting/Percent, press down > 3s	Power off
	Input data mode	ignore modification
	Menu selection mode	Prepare to exit from current working mode

Note:

Normally, the second function of one key need pressing it down more than 3s.

4. Operation Menu Structure

4.1 Main menu:

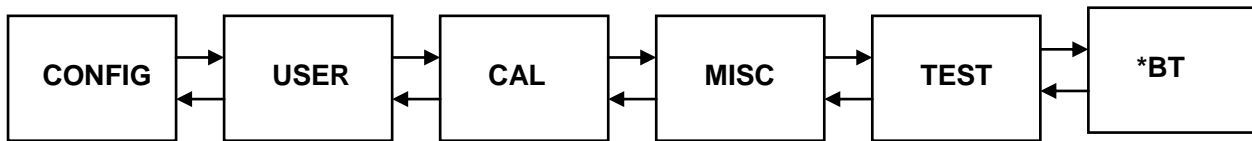

*NOTE: BT menu only be active when Blue tooth module is installed on COM3

4.2 CONFIG Submenu:

CONFIG				
Sub-Menu1	Sub-Menu2	Option	Remark	Final Set
CFG.ON CFG.OFF			seal switch is on or off	
RESET		NO YES	reset configure parameters to default setting	
REGULA		NONE USA CANADA EUROPE	select the standard that the scale will comply with: USA,CANADA, EUROPE	
PRIM.N		100 - 100,000	the division number under primary unit, if (REGULAR)≠none, the max is 10,000	
PRIM.D		0.0001 0.0002 0.0005 0.001 0.002 0.005 0.01 0.02 0.05 0.1 0.2 0.5 1 2 5 10 20 50	the division value under primary unit; the division value under second unit is automatically determined by indicator according to the division value under primary unit.	

PRIM.Ut		KG	select the primary unit from kg or lb, the second unit is the lb if kg selected as primary unit or kg if lb selected as primary unit; the calibration standard weight must be in primary unit!	
		LB		
SECND.N		100-125,000	the division number under second unit,the max is 1.25*(PRIM.N), and if(REGULAR)≠none, the max is 10,000	
10N.DSP		NO	Display weight at 10 times division number under primary unit, if (REGULAR)=none, no this item	
		YES		
MOTION		1-255	Check motion window: 1-255=±0.25d *(1-255), if (REGULAR)≠none, the max is 12	
OVER.LD		0-100	over load display limitation: 0=FS+9d, 1-100=101%FS -200%FS, if (REGULAR)≠none, the max is 10	
AD.FROM		ADC	Weight Data comes from: ADC=local A/D chip on PCB; COM3=COM3 interface;	
		COM3		
AD.H.SPD		NO	Speed of A/D convert: NO=10Hz; YES=80Hz; if AD.FROM=COM3,this item will not be shown	
		YES		
UNITS	KG	YES	Units that can be used by UNIT key select: YES=enable this unit to be used; NO=disable this unit to be used; Refer to section5.12 for some limitation; In trade application, lb:oz should not be allowed.	
		NO		
	LB	YES		
		NO		
	OZ	YES		
		NO		
	LBOZ	YES		
		NO		
G	YES			
	NO			
ZRO.PNT	IZSM	0-100	Initial zero(power on zero) point range: 0=no limitation, 1-100= (calibration zero point) ±1%FS - (calibration zero point) ±100%FS, If (REGULAR)≠none, the max is 10	
		IN.IZSM	WEIGHT	Choose which weight as current initial zero point when current weight is <u>in</u> IZSM range: WEIGHT= current weight ; CAL.ZRO= calibration zero; LAST.Z.T=switch-off zero and tare If (REGULAR)≠none, the value is fixed on WEIGHT
	CAL.ZRO			
	LAST.Z.T			
	OV.IZSM	DSP.OVR	Choose which weight as current initial zero point when current weight is <u>over</u> IZSM range: DSP.OVR=display initial zero is over; WEIGHT= current weight; CAL.ZRO= calibration zero; LAST.Z.T=switch-off zero and tare If (REGULAR)≠none, the value is fixed on DSP.OVR	
		WEIGHT		
		CAL.ZRO		
LAST.Z.T				

	SAZSM	0-100	Zero key range: 0=no limitation, 1-100= (initial zero point) $\pm 1\%FS$ - (initial zero point) $\pm 100\%FS$, if (REGULAR) \neq none, the max is 2	
	AZSM	0-100	Zero tracking window: 0=0d, no tracking; 1-100= $\pm(0.2+0.05*(1-100))d$ /s, if (REGULAR) \neq none, the max is 10	
FILTER	FLT1.TH	0-255	Enter digital filter1 threshold: 0=no filter1; 1-254=filter1 be used only when vibration in $\pm 0.5d*(1-254)$; 255= filter1 be always used	
	FLT1.ST	1-64	Digital filter1 intensity: 1-64 ADC's data will be averaged	
	FLT2.TH	0-255	Enter digital filter2 threshold: 0=no filter2; 1-254=filter2 be used only when vibration in $\pm 0.5d*(1-254)$; 255= filter2 be always used	
	FLT2.ST	0-255	Digital filter2 intensity: 0-255=weak to strong	
FUNC	HOLD	YES	Yes/No=enable/disable hold function; Operation refer to section8. In trade application HOLD function should be prohibited	
		NO		
	COUNT	YES	Yes/No=enable/disable counting function, Operations refer to section6.	
		NO		
	PERCNT	NO	Percent weighing function is enable or disable: (1)NO=disable; (2)100%=enable and display format is 100% ; (3)100.0%=enable and display format is 100.0%; (4)100.00%=enable and display format is 100.00%; Operations refer to section7	
		100%		
		100.0%		
		100.00%		
	BMI	YES	Yes/No=enable/disable BMI function, Operations refer to section8.	
		NO		
	COMPAR	YES	Yes/No=enable/disable data comparison function; Operations refer to section9	
		NO		
	ACCUMU	NO	Accumulation Mode selection: (1)NO=no accumulation function; (2)MANUAL=add up current number to accumulation memory after TATOL key is pressed; (3)AUTO=automatically add up current number to accumulation memory after scale is stable and weight is over (NLD.RNG)	
		MANUAL		
AUTO				
GEO.CAL	YES	Yes/No=enable/disable Geographical Adjustment Factor		
	NO			
WT.ADJ	YES	Yes/No=enable/disable weight fine-tuning using keypad in weighing mode, if (REGULAR) \neq none, this item is NO		
	NO			

*** The setting will be limited by choice of REGUALA**

4.3 USER Submenu:

USER				
Sub-Menu1	Sub-Menu2	Option	Remark	Set
RESET	NO	NO	reset user parameters to default setting	
	YES			
COM1	BAUD.RT	1200	selection of com1's baud rate	
		2400		
		4800		
		9600		
		19200		
		38400		
	BYT.FMT	8N1	selection of com1's byte format: (1)8N1=8 data bits, No parity check bit, 1 stop bit; (2)7O1=7 data bits, 1 Odd parity check bit, 1 stop bit; (3)7E1=7 data bits, 1 Even parity check bit, 1 stop bit; (4)7O2=7 data bits, 1 Odd parity check bit, 2 stop bit; (5)7E2=7 data bits, 1 Even parity check bit, 2 stop bit;	
		7O1		
		7E1		
		7O2		
		7E2		
	OUT.MOD	NONE	Selection com1 output mode: (1)NONE =No communication; (2)CONT=continuously output; (3)PRINT=output after PRINT key pressed; (4)CMD=output after a request command is received; (5)PRT.CMD= output after PRINT key pressed or request command received; (6)STABLE=output after scale is stable; Note: use PRINT or CMD to output data, the scale must be stable.	
		CONT		
		PRINT		
		CMD		
		PRTCMD		
		STABLE		
	LAYOUT	MULTPL	com1 output content and format set: (1)MULTPL= the following selected item in OUT1 will be output using defined format; (2)SINGLE= only displayed content and current status will be output, it's compatible with NCI-SCP01; (3) EH-SCP= Command –response mode, similar to Toledo PS60 protocol; (4) SCP-12 = only displayed content and current status will be output, it's compatible with NCI-SCP12 (NCI3835) ;	
		SINGLE		
EH-SCP				
SCP-12				
OUT1	SCAL.ID	YES	Yes/No=enable/disable output scale's ID number, Prompt is "SCALE ID"	
		NO		
	GROSS	YES	Yes/No=enable/disable output gross weight. Prompt is "GROSS"	
		NO		
	TARE	YES	Yes/No=enable/disable output tare weight. Prompt is "TARE"	
		NO		
	NET	YES	Yes/No=enable/disable output net weight. Prompt is "NET"	
		NO		
	PERCNT	YES	Yes/No=enable/disable output weight percentage. Prompt	

		NO	is "PERCENTAGE"	
UPCTWT		YES	Yes/No=enable/disable output weight of 1% percentage. Prompt is "1% REF WT"	
		NO		
COUNT		YES	Yes/No=enable/disable output counts. Prompt is "QUANTITY"	
		NO		
PCWT		YES	Yes/No=enable/disable output piece weight. Prompt is "PIECE WT"	
		NO		
BMI		YES	Yes/No=enable/disable output height and BMI. Prompt is "HEIGHT" and "BMI"	
		NO		
ACCUMU		YES	Yes/No=enable/disable output accumulation times and total. Prompt is "ACC. N" and "TOTAL"	
		NO		
DATE		YES	Yes/No=enable/disable output date. Prompt is "DATE"	
		NO		
TIME		YES	Yes/No=enable/disable output time. Prompt is "TIME"	
		NO		
AD.CODE		YES	Yes/No=enable/disable output ADC's code. Prompt is "A/D CODE"	
		NO		
BAT.VOL		YES	Yes/No=enable/disable output voltage of battery. Prompt is "VOLTAGE"	
		NO		
STATUS		YES	Yes/No=enable/disable output scale's status. Prompt is "STATUS"	
		NO		
B.LINE		NONE	How many blank lines after strings output: NONE=no blank line, LINE1/2/3/4=there're 1, 2,3 or 4 blank lines after strings, used for paper feed forward 1/2/3/4 lines.	
		LINE1		
		LINE2		
		LINE3		
		LINE4		
COM2	BAUD.RT	1200	selection of com2's baud rate	
		2400		
		4800		
		9600		
		19200		
		38400		
BYT.FMT		8N1	selection of com1's byte format: (1)8N1=8 data bits, No parity check bit, 1 stop bit; (2)7O1=7 data bits, 1 Odd parity check bit, 1 stop bit; (3)7E1=7 data bits, 1 Even parity check bit, 1 stop bit; (4)7O2=7 data bits, 1 Odd parity check bit, 2 stop bit; (5)7E2=7 data bits, 1 Even parity check bit, 2 stop bit;	
		7O1		
		7E1		
		7O2		
		7E2		
OUT.MOD		NONE	Selection com2 output mode: (1) NONE = No communication; (2) CONT=continuously output; (3)PRINT=output after PRINT key pressed; (4)CMD=output after a request command is received; (5)PRT.CMD= output after PRINT key pressed or request	
		CONT		
		PRINT		

		CMD	command received; (6)STABLE=output after scale is stable;	
		PRT.CMD	Note: use PRINT or CMD to output data, the scale must be stable.	
		STABLE		
	LAYOUT	MULTPL	com2 output content and format set: (1)MULTPL= the following selected item in OUT2 will be output use defined format; (2)SINGLE= only displayed content and current status will be output, it's compatible with NCI-SCP01; (3) EH-SCP= Command –response mode, similar to Toledo PS60 protocol; (4) SCP-12 = only displayed content and current status will be output, it's compatible with NCI-SCP12 (NCI3835) ;	
	SINGLE			
	EH-SCP			
	SCP-12			
OUT2	SCAL.ID	YES	Yes/No=enable/disable output scale's ID number, Prompt is "SCALE ID"	
		NO		
	GROSS	YES	Yes/No=enable/disable output gross weight. Prompt is "GROSS"	
		NO		
	TARE	YES	Yes/No=enable/disable output tare weight. Prompt is "TARE"	
		NO		
	NET	YES	Yes/No=enable/disable output net weight. Prompt is "NET"	
		NO		
	PERCNT	YES	Yes/No=enable/disable output weight percentage. Prompt is "PERCENTAGE"	
		NO		
	UPCTWT	YES	Yes/No=enable/disable output weight of 1% percentage. Prompt is "1% REF WT"	
		NO		
	COUNT	YES	Yes/No=enable/disable output counts. Prompt is "QUANTITY"	
		NO		
	PCWT	YES	Yes/No=enable/disable output piece weight. Prompt is "PIECE WT"	
		NO		
	BMI	YES	Yes/No=enable/disable output height and BMI. Prompt is "HEIGHT" and "BMI"	
		NO		
	ACCUMU	YES	Yes/No=enable/disable output accumulation times and total. Prompt is "ACC. N" and "TOTAL"	
		NO		
	DATE	YES	Yes/No=enable/disable output date. Prompt is "DATE"	
		NO		
	TIME	YES	Yes/No=enable/disable output time. Prompt is "TIME"	
		NO		
	AD.CODE	YES	Yes/No=enable/disable output ADC's code. Prompt is "A/D CODE"	
		NO		
	BAT.VOL	YES	Yes/No=enable/disable output voltage of battery. Prompt is "VOLTAGE"	
		NO		
STATUS	YES	Yes/No=enable/disable output scale's status. Prompt is "STATUS"		
	NO			
B.LINE	NONE	How many blank lines after strings output: NONE=no blank		

		LINE1	line, LINE1/2/3/4=there're 1, 2,3 or 4 blank lines after strings, used for paper feed forward 1/2/3/4 lines.	
		LINE2		
		LINE3		
		LINE4		
COM3*	BAUD.RT	1200	selection of com3's baud rate	
		2400		
		4800		
		9600		
		19200		
	BYT.FMT	8N1	selection of com1's byte format: (1)8N1=8 data bits, No parity check bit, 1 stop bit; (2)7O1=7 data bits, 1 Odd parity check bit, 1 stop bit; (3)7E1=7 data bits, 1 Even parity check bit, 1 stop bit; (4)7O2=7 data bits, 1 Odd parity check bit, 2 stop bit; (5)7E2=7 data bits, 1 Even parity check bit, 2 stop bit;	
		7O1		
		7E1		
		7O2		
		7E2		
	OUT.MOD	NONE	Select com3 output mode: (1) NONE = No communication ; (2)CONT=continuously output; (3)PRINT=output after PRINT key pressed; (4)CMD=output after a request command is received; (5)PRT.CMD= output after PRINT key pressed or request command received; (6)STABLE=output after scale is stable; Note: use PRINT or CMD to output data, the scale must be stable.	
		CONT		
		PRINT		
		CMD		
		PRTCMD		
		STABLE		
	LAYOUT	MULTPL	Com3 output content and format set: (1)MULTPL= the following selected item in OUT3 will be output use defined format; (2)SINGLE= only displayed content and current status will be output, it's compatible with NCI-SCP01; (3) EH-SCP= Command –response mode, similar to Toledo PS60 protocol; (4) SCP-12 = only displayed content and current status will be output, it's compatible with NCI-SCP12 (NCI3835) ;	
		SINGLE		
		EH-SCP		
		SCP-12		
OUT3*	SCAL.ID	YES	Yes/No=enable/disable output scale's ID number, Prompt is "SCALE ID"	
		NO		
	GROSS	YES	Yes/No=enable/disable output gross weight. Prompt is "GROSS"	
		NO		
	TARE	YES	Yes/No=enable/disable output tare weight. Prompt is "TARE"	
		NO		
	NET	YES	Yes/No=enable/disable output net weight. Prompt is "NET"	
		NO		
	PERCNT	YES	Yes/No=enable/disable output weight percentage. Prompt is "PERCENTAGE"	
		NO		
	UPCTWT	YES	Yes/No=enable/disable output weight of 1% percentage. Prompt is "1% REF WT"	
		NO		

COUNT	YES	Yes/No=enable/disable output counts. Prompt is "QUANTITY"		
	NO			
PCWT	YES	Yes/No=enable/disable output piece weight. Prompt is "PIECE WT"		
	NO			
BMI	YES	Yes/No=enable/disable output height and BMI. Prompt is "HEIGHT" and "BMI"		
	NO			
ACCUMU	YES	Yes/No=enable/disable output accumulation times and total. Prompt is "ACC. N" and "TOTAL"		
	NO			
DATE	YES	Yes/No=enable/disable output date. Prompt is "DATE"		
	NO			
TIME	YES	Yes/No=enable/disable output time. Prompt is "TIME"		
	NO			
AD.CODE	YES	Yes/No=enable/disable output ADC's code. Prompt is "A/D CODE"		
	NO			
BAT.VOL	YES	Yes/No=enable/disable output voltage of battery. Prompt is "VOLTAGE"		
	NO			
STATUS	YES	Yes/No=enable/disable output scale's status. Prompt is "STATUS"		
	NO			
B.LINE	NONE	How many blank lines after strings output: NONE=no blank line, LINE1/2/3/4=there're 1, 2,3 or 4 blank lines after strings, used for paper feed forward 1/2/3/4 lines.		
	LINE1			
	LINE2			
	LINE3			
	LINE4			
BEEP	KEY	YES	Yes/No=enable/disable beep after a key pressed down	
		NO		
COMPAR	NONE	(1)NONE=not beep; (2)L.Low=beep when lower than low limitation; (3)IN.LMT=beep when in range of low and high limitation; (4)O.HIGH=beep when over high limitation; (5)OUT.LMT=beep when lower than low limitation or higher than high limitation		
	L.LOW			
	IN.LMT			
	O.HIGH			
	OUT.LMT			
HOLD	HLD.MOD	NONE	HOLD Mode: (1)NONE=no hold function (2)PS.PEAK=Positive Peak number Hold mode: scale will display and refresh the positive peak value from last zero setting (3)NG.PEAK=Negative PEAK number Hold mode. it's Similar with PS.PEAK, but negative number is used. (4)TOGGLE=Press HOLD key to enter HOLD mode, if weight is over (NLD.RNG) and stable, the data will be frozen until press HOLD key again to exit. (5) AVERAG=Average HOLD mode: in this mode, if weight is over (NLD.RNG), and its variation is less than (HLD.RNG), the average data in (AVG.TIM) will be frozen. Press HOLD key or (HLD.TIM) time elapsed to exit this mode (6)AUTO=Auto hold mode: it's similar with AVERAG mode, but if the one held load is removed, and a new load that is over (NLD.RNG) put on scale, the new load will be automatically frozen.	
		PS.PEAK		
		NG.PEAK		
		TOGGLE		
		AVERAG		
		AUTO		
	AVG.TIM	1-60	average data time for HOLD mode: 1-60s	

	STB.TIM	3*AVG.TIM - 255	Waiting time for scale stable in HOLD mode: 3*(AVG.TIM) - 255S	
	HLD.TIM	0-65535	Data HOLD time: 0=data will be frozen until HOLD key pressed; 1-65535=data frozen time is 1-65535s, after the time elapses, scale will exit HOLD mode	
	HLD.RNG	0 - 255	Vibration range of data that can be averaged and held in HOLD mode: 0=any data can be averaged; 1-255= only the data which vibration is in 1-255d can be averaged and held;	
OTHER	NLD.RNG	1-255	1-255=the range of weight is 1-255d; when current weight is less than this value, the scale can be regarded as empty , or the load on scale is removed. It must be bigger than (CONFI.MOTION).	
	CMD.SRC	NONE	Source of the executed command selection: (1)NONE=no any command will be executed; (2)COM.1/.2/.3= command from COM1/2/3 will be executed; (3)COM.1.2/.1.3/.2.3/= command from COM1,COM2/COM1,COM3 or COM2,COM3 will be executed; (4)COM.1.2.3= command from COM1,COM2 or COM3 will be executed; NOTE: if AD.FROM=COM3 , then COM.x.x.3 will not be active	
		COM.1		
		COM.2		
		COM.1.2		
		COM.3		
		COM.1.3		
		COM.2.3		
	COM.1.2.3			
	A.OFF.T	0-255	Auto off time: 0=not auto power off; 1-255=auto power off after 1-255 minutes, in this period, no operation or no weight changing	
OFF.MD	OFF	Auto off mode: (1)OFF=turn off instrument; (2)DSP.TIM= display time; (3)AC.TIME=turn off when only battery is used, display time when AC adaptor is used. If time is displayed and enabled continuously output to COMx, the time will be sent out		
	DSP.TIM			
	AC.TIME			
LCD.BLT	0-255	LCD backlight set: (1)0=always off (2)1=always on (2)2=press down ZERO+UNIT together more than 3s to turn on or turn off (4)3-255=auto on when key operation or weight changing, auto off after 3-255s elapsed		
LCD.CST	CST1---8	LCD contraction level selection		
SCAL.ID	000000- 999999	scale's ID number: 000000-999999		

NOTE: if **AD.FROM=COM3**, then COM3 and OUT3 will not be active !

4.4 CAL Submenu:

CAL			
SUBMENU1	SUBMENU2	OPTION	REMARK
CAL.ON CAL.OFF			seal switch is on or off
ZERO			only do zero point calibration, then go to CAL.END to end
LINE	CAL.P0		Linear calibration point0: do zero point calibration, this point can't be omitted.
	CAL.P1		Linear calibration point1: do first weight point calibration, this point can't be omitted and standard weight must be over 10%FS.
	END.Y	YES	End calibration? YES=go to CAL.END to end; NO=go to do next point calibration
		NO	
	CAL.P2		Linear calibration point2: do second weight point calibration, standard weight must be over 10%FS and be larger than it in CAL.P1, this point can be omitted.
	END.Y	YES	End calibration? YES=go to CAL.END to end; NO=go to do next point calibration
NO			
CAL.P3		Linear calibration point3: do third weight point calibration, standard weight must be over 10%FS and be larger than it in CAL.P2, this point can be omitted.	
GEO	CODE	00-70	Selection of Geographical Position Code 00-70, refer TABLE12-1
	GRAVT	9.76183 -9.99999	Input Gravity of User Location by keyboard
INPUT			Input or view calibration parameters value
CAL.END			calibration end and restart

NOTE:

The details can be referred in section “**12.CALIBRATION**”

4.5 MISC Submenu:

MISC	
SUBMENU1	REMARK
CODE	display ADC's code, this code can be after no-filter, filter1 or filter2; details refer to section14
VOL	display voltage; calibrate voltage; details refer to section15
DATE	display date and set date; details refer to section17
TIME	display time and set time; details refer to section16
VER	display firmware version; details refer to section18

4.6 TEST Submenu:

TEST	
SUBMENU1	REMARK
DISP.TST	test LCD or LED; details refer to section19
COM1.RD	test COM1 receiving; details refer to section21
COM1.TD	test COM1 transmitting; details refer to section22
COM2.RD	test COM2 receiving; details refer to section21
COM2.TD	test COM2 transmitting; details refer to section22
KEY.TST	test keys and buzzer; details refer to section20

4.7 BT Submenu:

BT	
SUBMENU1	REMARK
BT...?	Go to Blue Tooth module setup mode. Refer section "24. Bluetooth Configuration"
INIT	To initialize blue tooth module some parameters: In initialization, INIT.i will be shown, i=1/2/3..., this means processing initialization step1/2/3... These parameters including: (1) Set no flow control in serial communication (2) Set local blue tooth name to EHBTxxxxxx (xxxxxx is last six address of local blue tooth) (3) Set always need authentication to access the Blue tooth in the indicator (4) Set blue tooth device type to 000000 (5) Set blue tooth module function is only serial communication (6) Set to throw away all received data before the module connection (7) Set BAUD=9600bps, UARTMD=8N1, PASSWD=1234,TYPE=0=slave (8) Set ROLE=0=slave, MAXCON=1,BIND=0=not bind address (9) Clear all memorized address
LADD	Go to display Local blue tooth address mode, The address will shown in Li.xxxx format, i=1/2/3, xxxx is four hexadecimal digits
RADD	Go to display or input Remote blue tooth address mode, The address will shown in Ri.xxxx format, i=1/2/3, xxxx is four hexadecimal digits
BAUD	Set or view serial communication baud rate : 1200-2400-4800-9600-19200-38400, default is 9600
UARTMD	Set or view serial communication mode: 8N1-7O1-7E1-7O2-7E2 (1) stop bit=1/2 bit stop bits; (2)parity bit=N(none)/O(odd)/E(even); default is 8N1
PASSWD	Set or view access password
TYPE	Set or view type of device: 0=slave; 1=master; 2=repeater; 3=relay node
ROLE	Set or view device role: 0=slave,1-7=master, and can connect 1-7 devices; default is slave
MAXCON	Set maxim number of connected devices: 0-7, default=1
BIND	Set or view whether address binding is need: 0=no binding, 1=bind address; default=0
CLRADR	Clear all memorized address
BTVER	View the version of device

Note:

Only proper blue tooth module is installed (e.g BTM0304C1H, BTM0804C2H...) on COM3, corresponding items can be active! Details refer to section24.

5. Normal Weighing mode

- 5.1 During key operation, please note to use the second function of one key need pressing the key over 3 seconds; To input data or select menu, use ← ↑ ↓ → ←↵ ↵→ to process.
- 5.2 **Power on scale:** when scale is off, short press **ON/OFF** key to turn on;
Power off scale: when scale is on, long press **ON/OFF** key to turn off the scale.
- 5.3 **Change working mode:** long press **FUNC** key, then use ↑ ↓ ←↵ to choose and confirm to enter into weighing mode, counting mode or percentage working mode
- 5.4 **Enter to or exit from HOLD mode:** press **HOLD** key
- 5.5 **ZERO:** When the weights is stable and within the zero range, press **ZERO** key to set new zero point. Please refer the ZERO and TARE limitations in 5.9 section.
- 5.6 **TARE:** When the gross weight is big than zero, and the scale is stable, press **TARE** key, the indicator will show net weight of zero, the NET annunciator will be lighted. Please refer the ZERO and TARE limitations in 5.9 section.
- 5.7 **Preset tare weight:** long press **PRESET** key, Pr.Tare will show, and the TARE annunciator flashes, it means it is in preset TARE weight mode, use ← ↑ ↓ → ←↵ to input tare weight, and its unit is same as the unit that it used before, there's no limitation to preset tare weight, but it should bigger than zero. After input a tare weight, "NET" annunciator will be lighted. Note: this indicator can only save one tare weight, the new tare weight will automatically replace the old one. Also, please refer the ZERO and TARE limitations in 5.9 section
- 5.8 **Clear tare weight:** remove any weight on platform, wait till the scale is stable, short press **TARE** key, please refer the ZERO and TARE limitations in 5.9section.

5.9 Limitation to ZERO and TARE operation under different conditions:

Table5-1

Standard	Weight on platform	Data in TARE memory unit	key function	
			Tare key	Zero key
USA	≤ 0	no	No action	Zero
		yes	Clear the tared weight	
	> 0	No	Tare	
		Yes		
Canada	≤ 0	no	No action	Zero
		Yes	Clear the tared weight	
	> 0	No	Tare	
		Yes	No action	
Europe	≤ 0	No	No action	Zero
		Yes	Clear the tared weight	zero and clear the tared weight
	> 0	No	Tare	zero
		Yes		zero and clear the tared weight
None (same with Europe)	≤ 0	No	No action	Zero
		yes	Clear the tared weight	zero and clear the tared weight
	> 0	No	Tare	zero
		yes		zero and clear the tared weight

- NOTE: (1) ZERO only be active when scale is stable and weight is in SAZSM setting range.
 (2) TARE only be active when scale is stable
 (3) Clear TARE weight or ZERO scale, make indicator to enter displaying GROSS mode
 (4) TARE weight, make indicator to enter displaying NET mode

5.10 **Output data:** When scale is stable, press **PRINT** key.

5.11 **Accumulation:**

Press ACC key to add displayed number to accumulation memories, and accumulation times will also add up 1. and then to display accumulation result

5.12 **Change Weight UNIT:**

Short press **UNIT** key to select kg, lb, lb:oz, g, or oz unit, note: under some condition, g and lb:oz is not available. And , In trade application, lb:oz should be prohibited. Please refer the following tables:

Table5-2: use Kg as primary unit:

Calibration division value	Display division value in different weight unit that can be used				
	kg	g	lb	oz	lb:oz
0.0001kg	0.0001kg	0.1g	0.0002lb	0.005oz	Not available
0.001kg	0.001kg	1g	0.002lb	0.05oz	Not available
0.01kg	0.01kg	10g	0.02lb	0.5oz	0.5oz
0.1kg	0.1kg	100g	0.2lb	5oz	Not available
1kg	1kg	Not available	2lb	50oz	Not available
10kg	10kg	Not available	20 lb	Not available	Not available
0.0002kg	0.0002kg	0.2g	0.0005 lb	0.01oz	Not available
0.002kg	0.002kg	2g	0.005 lb	0.1oz	0.1 oz
0.02kg	0.02kg	20g	0.05 lb	1oz	1 oz
0.2kg	0.2kg	200g	0.5 lb	10oz	Not available
2kg	2kg	Not available	5 lb	Not available	Not available
20kg	20kg	Not available	50 lb	Not available	Not available
0.0005kg	0.0005kg	0.5g	0.001 lb	0.02oz	Not available
0.005kg	0.005kg	5g	0.01 lb	0.2oz	0.2 oz
0.05kg	0.05kg	50g	0.1 lb	2oz	2oz
0.5kg	0.5kg	500g	1 lb	20oz	Not available
5kg	5kg	Not available	10 lb	Not available	Not available
50kg	50kg	Not available	Not available	Not available	Not available

Table5-3: use LB as primary unit:

Calibration division value	Display division value in different weight unit that can be used				
	kg	g	lb	oz	lb:oz
0.0001lb	Not available	Not available	0.0001lb	0.002oz	Not available
0.001 lb	0.0005 kg	0.5g	0.001 lb	0.02oz	Not available
0.01 lb	0.005 kg	5g	0.01 lb	0.2oz	0.2 oz
0.1 lb	0.05 kg	50g	0.1 lb	2oz	2 oz
1 lb	0.5 kg	500g	1 lb	20oz	Not available
10 lb	5 kg	Not available	10 lb	Not available	Not available
0.0002 lb	0.0001 kg	0.1g	0.0002 lb	0.005 oz	Not available
0.002 lb	0.001 kg	1g	0.002 lb	0.05 oz	Not available
0.02 lb	0.01 kg	10g	0.02 lb	0.5 oz	0.5 oz
0.2 lb	0.1 kg	100g	0.2 lb	5 oz	Not available
2 lb	1 kg	Not available	2 lb	50 oz	Not available
20 lb	10 kg	Not available	20 lb	Not available	Not available
0.0005 lb	0.0002 kg	0.2g	0.0005 lb	0.01 oz	Not available
0.005 lb	0.002 kg	2g	0.005 lb	0.1 oz	0.1 oz
0.05 lb	0.02 kg	20g	0.05 lb	1 oz	1 oz
0.5 lb	0.2 kg	200g	0.5 lb	10 oz	Not available
5 lb	2 kg	Not available	5 lb	Not available	Not available
50 lb	20 kg	Not available	50 lb	Not available	Not available

5.13 Check Weight in weighing mode:

- 5.13.1 To make weight compare function be available, **CONFIG-FUNC-COMPAR** item should set to **YES**, and high and low limitation of weight should be set correctly according to following steps:
- 5.13.2 In weighing mode, Press down **DATA** key more than 3s to input compare data of high and low.
- 5.13.3 After **HIGH** being shown, 000000 will be displayed, use **PRINT, ACC, UNIT** key to input high weight number and press **TARE** key to confirm. Annunciator of **Hi** will be shown in this step. Press **ZERO** key to exit and back to weighing mode.
- 5.13.4 After **Low** being shown, 000000 will be displayed, use **PRINT, ACC, UNIT** key to input low weight number and press **TARE** key to confirm. Annunciator of **Lo** will be shown in this step. Press **ZERO** key to exit and back to weighing mode.
- NOTE:** If High number is 0 or is equal or less than low number, the comparison will be disabled, and the input data has no limitation.
- 5.13.5 After a reasonable limitation is set and compare is be active, one of annunciators **HI, OK, LO** will be lighted, and the beeper will sound according to its setting in **USER-BEEP**.

5.14 Enter Setup Mode:

- 5.14.1 If need to set configuration parameters, set user parameters, calibrate the scale, set current date or time, test some hardware... It's need to long press **SETUP** key to enter setup mode
- 5.14.2 After Entering Setup Mode, the main menu item **CONFIG** will be shown first.
- 5.14.3 In Setup mode, use ← ↑ ↓ → ↶ ↷ to select wanted submenu and wanted menu item, select wanted choice, set wanted number, confirm and save data, or exit this mode. Please refer the "4.Operation Menu Structure".

6. Count Weighing Mode

- 6.1 In this mode, scale will weigh goods weight on scale, calculate and display its counts after the piece weight of goods is obtained
- 6.2 To make counting function be available, **CONFIG-FUNC-COUNT** item should be set to **YES** in **CONFIG** menu.
- 6.3 To enter counting working mode, in normal weighing or percent-weighing mode, long press **FUNC** key, **WEIGH/PERCEN** will be shown, use **ACC** or **PRINT** key to select **COUNT**, then press **TARE** to confirm go to parts counting mode. Before new piece weight is got, the last piece weight will be used.
- 6.4 In counting working mode, the function of **ZERO, TARE, PRINT, HOLD, PRESET TARE, ACC, SETUP, ON/OFF** are available.
- 6.5 There're two ways to obtain the piece weight: (1) input piece weight directly, refer operations of step6.5.1 (2)weigh samples weight which quantity is known, refer operation of step6.5.2
- 6.5.1 Input piece weight from keypad: in counting mode, press **UNIT** key, When **InP.PWt** is shown, press **TARE** key to enter input piece weight mode.

- 6.5.1.1 When **UNIT.KG** is shown, use **PRINT** or **ACC** key to select the unit of piece weight, use **TARE** key to confirm and go to next. Press **ZERO** key to exit getting piece weight mode and back to counting mode.
- 6.5.1.2 When last stored piece weight is shown, use **PRINT**, **ACC**, **UNIT** key to input new piece weight, press **SETUP** key more than 3s to input decimal point. Press **TARE** key to confirm and save it, then go back to counting mode. If the input piece weight is less than 0.5d, the indicator will display **PWt.Er** and go back to counting mode.
- 6.5.2 Obtain piece weight by weighing samples weight which quantity: in counting mode, press **UNIT** key, When **InP.PWt** is shown, use **PRINT** or **ACC** key to select **SPL.PWT**, press **TARE** key to weigh samples (which quantity is known) weight, calculate piece weight. Press **ZERO** key to exit getting piece weight mode and back to counting mode.
- 6.5.2.1 When **SPL.Lo** is shown, move away any sample on scale and press **TARE** key to confirm, before scale is stable, **SPL.Lo** will be flashed. After it is stable, it will go to next step. Press **ZERO** key to exit getting piece weight mode and back to counting mode.
- 6.5.2.2 When **SPL.Hi** is shown, put samples (its quantity is known) onto the scale, Press **TARE** key to confirm reading weight. Before scale is stable, **SPL.Hi** will be flashed. After it is stable, it will go to next step. Press **ZERO** key to exit getting piece weight mode and back to counting mode.
- 6.5.2.3 After **INP.PCS** being shown, 000000 will be displayed, use **PRINT**, **ACC**, **UNIT** key to input the quantity of samples and Press **TARE** key to confirm. If the calculated piece weight is less than 0.5d, the indicator will display **PWt.Er** and go back to counting mode, otherwise, after the reasonable piece weight being got, the scale will go back to counting mode. The got piece weight can be saved after the power off and can be used next time.
- 6.6 **Check Counts (counts compare)** in Counting mode:
- 6.6.1 To make counts compare function be available, **CONFIG-FUNC-COMPAR** item should set to **YES**, and high and low limitation of pieces should be set correctly according to following steps:
- 6.6.2 In counting working mode, Press down **DATA** key more than 3s to input compare data of high and low.
- 6.6.3 After **HIGH** being shown, 000000 will be displayed, use **PRINT**, **ACC**, **UNIT** key to input high quantity number and press **TARE** key to confirm. Annunciator of **Hi** will be shown in this step. Press **ZERO** key to exit getting piece weight mode and back to counting mode.
- 6.6.4 After **Low** being shown, 000000 will be displayed, use **PRINT**, **ACC**, **UNIT** key to input low quantity number and press **TARE** key to confirm. Annunciator of **Lo** will be shown in this step. Press **ZERO** key to exit getting piece weight mode and back to counting mode.
- NOTE:** If High number is 0 or is equal or less than low number, the comparison will be disabled.
- 6.6.5 After a reasonable limitation is set and compare is be active, one of annunciators **HI**, **OK**, **LO** will be lighted, and the beeper will sound according to its setting in **USER-BEEP**.

7. Percent Weighing Mode

- 7.1 In this mode, scale will weigh goods weight on it, calculate and display its percentage after the unit-percentage-weight of goods is obtained. (NOTE: If 100% display format is set to 100%, 100.0% or 100.00% in CONFIG-FUNC-PERCEN menu item, then, the unit-percentage-weight is the weight of 1%, 0.1% or 0.01%)
- 7.2 To make percent weighing function be available, **CONFIG-FUNC-PERCEN** menu item shouldn't be set to **NONE**.
- 7.3 To enter percent weighing mode, in normal weighing or counting mode, long press **FUNC** key, **WEIGH/COUNT** will be shown, use **ACC** or **PRINT** key to select **PERCEN**, then press **TARE** to confirm go to percent weighing mode. Before new unit-percentage-weight is got, the last unit-percentage-weight will be used.
- 7.4 In percent weighing mode, the function of **ZERO**, **TARE**, **PRINT**, **HOLD**, **PRESET TARE**, **ACC**, **SETUP**, **ON/OFF** are available.
- 7.5 To obtain the unit-percentage-weight, there're two ways : (1) input weight and its percentage, then scale calculates the unit-percentage-weight, refer operations of step7.5.1 (2) weigh samples weight which percentage is known, refer operation of step7.5.2
- 7.5.1 Input weight and its percentage from keypad, and calculate unit-percentage-weight: in percent weighing mode, press **UNIT** key, When **InP.Pct** is shown, press **TARE** key to enter this mode:
- 7.5.1.1 Before input weight, use **PRINT** or **ACC** key to select the percentage from 1%, 2%, 5%, 10%, 20%, 50% and 100%, this percentage is corresponding to the weight you will input in following steps
- 7.5.1.2 When **UNIT.KG** is shown, use **PRINT** or **ACC** key to select the unit of input weight, use **TARE** key to confirm and go to next. Press **ZERO** key to exit and back to percent weighing mode.
- 7.5.1.3 When last stored unit-percentage-weight data is shown, use **PRINT**, **ACC**, **UNIT** key to input new unit-percentage-weight, press **HOLD** key more than 3s to input decimal point. Press **TARE** key to confirm and save it, then go back to percent weighing mode. If the calculated unit-percentage-weight is less than 0.5d, the indicator will display **Pct.Er** and go back to percent weighing mode.
- 7.5.2 Obtain unit-percentage-weight by weighing samples weight which percentage is known: in percent weighing mode, press **UNIT** key, When **InP.Pct** is shown, use **PRINT** or **ACC** key to select **SPL.Pct**, press **TARE** key to weigh samples (which percentage is known) weight, calculate piece weight. Press **ZERO** key to exit and back to percent weighing mode.
- 7.5.2.1 When **SPL.Lo** is shown, move away any sample on scale and press **TARE** key to confirm, before scale is stable, **SPL.Lo** will be flashed. After it is stable, it will go to next step. Press **ZERO** key to exit and back to percent weighing mode.
- 7.5.2.2 When **SPL.Hi** is shown, put samples (its percentage is known) onto the scale, Press **TARE** key to confirm reading weight. Before scale is stable, **SPL.Hi** will be flashed. After it is stable, it will go to next step. Press **ZERO** key to exit and back to percent weighing mode.
- 7.5.2.3 After **INP.PCT** being shown, 000000(position of decimal point is determined by **CONFIG-FUNC-PERCEN** setting) will be displayed, use **PRINT**, **ACC**, **UNIT** key to input the

percentage of samples and Press **TARE** key to confirm. If the calculated unit-percentage-weight is less than 0.5d, the indicator will display **Pct.Er** and go back to percent weighing mode, otherwise, after the reasonable unit-percentage-weight being got, the scale will go back to percent weighing mode. The got unit-percentage-weight can be saved after the power off and can be used next time.

7.6 **Check Percent (percentage compare)** in Percent weighing mode:

7.6.1 To make percentage compare function be available, **CONFIG-FUNC-COMPAR** menu item should set to **YES**, and high and low limitation of percentage should be set correctly according to following steps:

7.6.2 In percent weighing mode, Press down **DATA** key more than 3s to input compare data of high and low.

7.6.3 After **HIGH** being shown, 000000 will be displayed, use **PRINT, ACC, UNIT** key to input high percentage number and press **TARE** key to confirm. Annunciator of **Hi** will be shown in this step. Press **ZERO** key to exit and back to percent weighing mode.

7.6.4 After **Low** being shown, 000000 will be displayed, use **PRINT, ACC, UNIT** key to input low percentage number and press **TARE** key to confirm. Annunciator of **Lo** will be shown in this step. Press **ZERO** key to exit and back to counting mode.

NOTE: If High number is 0 or is equal or less than low number, the comparison will be disabled.

7.6.5 After a reasonable limitation is set and compare is be active, one of annunciators **HI, OK, LO** will be lighted, and the beeper will sound according to its setting in **USER-BEEP**.

8. BMI Working Mode

8.1 To make BMI working Mode be available, **CONFIG-FUNC-BMI** menu item should be set to **YES** and factory setting should be also enable this function

8.2 To enter BMI Working mode:

8.2.1 When **CONFIG-FUNC-ACCUMU= Yes:** If In normal weighing mode, percent weighing mode, or counting mode, long press **FUNC** key, one of **WEIGH/COUNT/PERCEN** will be shown, use **ACC** or **PRINT** key to select **BMI**, then press **TARE** to confirm go to BMI mode.

8.2.2 When **CONFIG-FUNC-ACCUMU= NO:** press **BMI (ACC)** key, go to BMI mode.

8.3 After scale go to this mode, "CM.xxx" (means: last input height is xxx cm) or "IN.xx.x" (means: last input height is xx.x inch) will be displayed, and to wait for input height: (1)to change height unit to cm or inch by pressing **DATA** key; (2) to change height number by using **PRINT, ACC(BMI)** keys (3)Press and hold down **PRINT or ACC(BMI)** key will increase or decrease number fast, (4) Press **TARE** key to confirm the input. Press **ON/OFF** key to exit input data mode and back to BMI working mode. The range of height is 50-250cm(19.7-98.4inch) and default is 170cm(66.9inch)

8.4 In this mode, when BMI number is shown (BMI annunciato is on also), or weight number is shown (BMI and kg or lb annunciators are on), Press **ACC** key to select weight or BMI number to be displayed, when weight is displayed, the weight unit can be selected by pressing **UNIT** key, and BMI and weight unit will be displayed at same time.

8.5 In this mode, when current net weight is less than **NLD.RNG**, the indicator will go to display weight number if **CONFIG-FUNC-ACCUMU= No**; or the indicator will back to original working mode if **CONFIG-FUNC-ACCUMU= Yes**.

9. HOLD Function

NOTE: *In trade application, HOLD function may not be allowed, please check with your local legal organization of measurement!*

9.1 **HOLD** function can be used to freeze display number. In this mode, scale can catch a dynamic number, hold a stable number, or average a unstable number, then HOLD (freeze) this number temporary for user to watch or record. This function can be used in normal weighing mode, counting mode and percent weighing mode. After entering **HOLD** mode, the speed of A/D converter can be increased to 80Hz (if **CONFIG-AD.H.SPD** is set to YES) from original 10Hz for some dynamic weighing applications. With the hold function, it is possible to weigh restless weighing samples such as live animals, moving objects. The indicator provides special mode settings to accommodate sample's movements.

9.2 To make **HOLD** function be active, the **CONFIG-FUNC-HOLD** menu item must be set to **YES**; menu items of **USER-HOLD-HLD.MOD** **/-AVG.TIM** **/-HLD.TIM** **/-HLD.RNG** **/-STB.TIM**, **USER-OTHER-NLD.RNG** need be set to reasonable value.

To speedup sampling of weight, set **CONFIG-AD.H.SPD** menu item to YES.

To enter **HOLD** working mode, press down **HOLD** key when scale works in normal weighing mode, counting mode or percent weighing mode.

9.3 There're several **HOLD** mode to freeze display data:

- (1) Positive Peak Number HOLD mode
- (2) Negative Peak Number HOLD mode
- (3) Toggle HOLD mode
- (4) Average HOLD mode
- (5) Auto HOLD mode

The following are details of these HOLD modes:

9.3.1 **Positive Peak HOLD:**

When **USER-HOLD-HLD.MOD** is set to **PS.PEAK**, the hold mode is positive peak hold mode. When scale first enters this working mode, it will display the largest positive number that is from the time of zero-point set. After entering this working mode, scale will always catches and refresh positive larger number and display it. To exit **HOLD** mode, press **HOLD** key again.

9.3.2 **Negative Peak HOLD:**

When **USER-HOLD-HLD.MOD** is set to **NG.PEAK**, the hold mode is negative peak hold mode. When scale first enters this working mode, it will display the largest negative number that is from the time of zero-point set. After entering this working mode, scale will always catches negative larger number and display it. To exit **HOLD** mode, press **HOLD** key again.

9.3.3 **Toggle HOLD:**

When **USER-HOLD-HLD.MOD** is set to **TOGGLE**, the hold mode is toggle hold mode ---a manual Hold function. After entering this working mode, scale will freeze and display number if scale is stable. Only the weight that is over **USER-OTHER-NLD.RNG** (zero 'dead' band) can be held. To exit **HOLD** mode,

press **HOLD** key again. If the time of scale being unstable is more than **USER-HOLD-STB.TIM**, **STB.ER** will be shown, press **TARE** key to start averaging again, or press **HOLD** key to exit.

9.3.4 Average HOLD:

When **USER-HOLD-HLD.MOD** is set to **AVERAG**, the hold mode is average hold mode. After entering this working mode, scale will freeze and display number if scale is stable. If scale is not stable, but the variation is less than **USER-HOLD-HLD.RNG**, scale will average data in **USER-HOLD-AVG.TIM**, then freeze and display the number. Only the weight that is over **USER-OTHER-NLD.RNG** can be frozen. Scale will exit HOLD mode according to the setting of **USER-HOLD-HLD.TIM**. If the time of scale variation being over **USER-OTHER-NLD.RNG** is more than **USER-HOLD-STB.TIM**, **STB.ER** will be shown, press **TARE** to start averaging again, or press **HOLD** key to exit.

9.3.5 Auto HOLD:

When **USER-HOLD-HLD.MOD** is set to **AUTO**, the hold mode is auto hold mode--- different subjects can be weighed one after another without pressing any buttons. After entering this working mode, scale will freeze and display number if scale is stable. If scale is not stable, but the variation is less than **USER-HOLD-HLD.RNG**, scale will average data in **USER-HOLD-AVG.TIM**, then freeze and display the number. Only the weight that is over **USER-OTHER-NLD.RNG** can be frozen. If the held weight is moved away, and a new load put on the scale, scale will automatically hold new number of load. Scale will exit HOLD mode according to the setting of **USER-HOLD-HLD.TIM**. If the time of scale variation being over **USER-OTHER-NLD.RNG** is more than **USER-HOLD-STB.TIM**, **STB.ER** will be shown, press **TARE** to start averaging again, or press **HOLD** key to exit.

9.4 In Positive or Negative Peak HOLD mode, the red HOLD (for LED version) or PEAK and HOLD (for LCD version) annunciator will be lighted, in other HOLD mode, green HOLD (for LED version) or HOLD (for LCD version) annunciator will be lighted. When HOLD annunciator flash, the displayed number is live, When HOLD annunciator become steady, the displayed number is frozen.

10. Data Compare Function

10.1 Data compare function can be used in normal weighing mode, counting mode and percent weighing mode, and call it as Check Weight, Check Counts and Check Percentage. When this function is enabled, you can set a higher and a lower limitation of weight, counts or percentage independently, and these limitation can be saved permanently. Then, the current data of weight, counts or percentage will be compared with the setting limitation, and corresponding annunciator will be lighted.

10.2 To make data compare function be available, **CONFIG-FUNC-COMPAR** menu item should set to **YES**, and high and low limitation should be set correctly according to following steps:

10.3 In normal weighing mode, counting mode or percent weighing mode, Press down **DATA** key more than 3s to enter input compare data of high and low mode.

10.4 After **HIGH** being shown, last setting data of high will be displayed, use **PRINT**, **ACC**, **UNIT** key to input new number of high and press **TARE** key to confirm. Annunciator of **Hi** will be shown in this step. Press **ZERO** key to exit and back to original working mode.

10.5 After **Low** being shown, last setting of low will be displayed, use **PRINT, ACC, UNIT** key to input new number of low and press **TARE** key to confirm. Annunciator of **Lo** will be shown in this step. Press **ZERO** key to exit and back to original working mode.

NOTE: *If High number is 0 or is equal or less than low number, the comparison will be disabled.*

10.6 After a reasonable limitation is set and compare function is be active, one of annunciators **HI, OK, LO** will be lighted, and the beeper will sound according to its setting in **USER-BEEP**.

10.7 For details, please refer to section of section 5.13, 6.6 and 7.6

11. Accumulation

11.1 Accumulation function can be used in normal weighing mode, counting mode and percent weighing mode, When this function is enabled, you can accumulate current net weight, piece, and percentage. Note, only the load on scale is larger than **USER-OTHER-NLD.RNG**, the displayed positive number can be added up. The accumulation times and total can be displayed or printed.

11.2 To make data accumulation function be available, **CONFIG-FUNC-ACCUMU** menu item should set to **MANUAL** or **AUTO**, Following are details.

11.3 When **CONFIG-FUNC-ACCUMU** is set to **MANUAL**, the stable and positive displayed net weight (must be larger than **USER-OTHER-NLD.RNG**), piece or percentage can be accumulated by long pressing **TOTAL** key, and indicator will display accumulation times first, and then display total of number. To avoid repeating accumulation for same load, one load only can be accumulated once. So, before a new load put onto the scale, the original load should be removed and let load on scale be smaller than **USER-OTHER-NLD.RNG**.

11.4 When **CONFIG-FUNC-ACCUMU** is set to **AUTO**, the stable and positive displayed net weight (must be larger than **USER-OTHER-NLD.RNG**), piece or percentage can be accumulated automatically, and indicator will display accumulation times first, and then display total of number. To avoid repeating accumulation for same load, one load only can be accumulated once. So, before a new load put onto the scale, the original load should be removed and let load on scale be smaller than **USER-OTHER-NLD.RNG**.

11.5 To view total, when display number is zero, long pressing **TOTAL** key, and indicator will display accumulation times first, and then display total of number. It will alternative display accumulation times and weight (or quantity, or percentages) until the **TOTAL** key being pressed again.

NOTE:

*When HOLD function is enable, and scale is working in PEAK HOLD mode (**CONFIG-HOLD=YES, USER-HOLD-HLD.MOD=PS.PEAK/NG.PEAK**), Accumulation function will be automatically disabled!!!*

12. Calibration

Note:

- (1) Before calibrate the scale, you should prepare a standard weight (more than 10% of FS weight) for calibration.
- (2) In following steps, to press **ON/OFF** will show “EXIT?”, and press **ON/OFF** again or press **TARE** will exit calibration

- 12.1 Go to setup mode, select “CAL”, then press **TARE** to confirm to enter calibration mode.
- 12.2 After entering this mode, the number of this indicator has been calibrated will be shown first, this number will be increased one after every calibration and calibration data saved, and this counter can't be modified or erased by any other ways, it counts from 0000 to 9999, when it reaches 9999, it starts over at 0000. After the counter number being displayed, it will show “**CAL.OFF**” or “**CAL-ON**” according to the status of the sealed calibration switch is OFF or ON. If the switch is OFF, the following steps can be done, but the result will not be saved. Press **TARE** key to go to next step.
- 12.3 When “**ZERO**” is shown, use **PRINT** or **ACC** key to select do zero point calibration (refer step12.4), do linearity calibration (refer step12.5), do Geographical calibration (refer step 12.6) or Input/view calibration parameters value (refer step 12.7).
- 12.4 When **ZERO** is selected, remove all weight on scale and then press **TARE** key to confirm, the **ZERO** will flash when in catching zero point state. After getting reasonable data, it automatically goes to step12.8
- 12.5 When **LINE** is selected, press **TARE** key to confirm to enter linearity calibration.
 - 12.5.1 0% weight will be displayed after **CAL.P0** being shown, remove all weight on scale and then press **TARE** to confirm to calibrate the zero point; the zero weight will flash in catching zero point state. After getting the reasonable zero-point data, the zero weight will become steady and then go to next step.
 - 12.5.2 When first default standard weight is displayed after **CAL.P1** being shown. It will be calibrated on standard weight for first point. Put corresponding weight (more than 10%FS weight) onto scale. The default standard weight is 100%FS.

Use **PRINT, ACC, UNIT** keys to input the value of the loaded weight. Before input this value, you can long press DATA key to change weight's unit to kg or lb. Press **TARE** key to confirm, then, the indicator will flash the input standard weight.

When this weight number becomes steady, it means the stable and reasonable data corresponding to the standard weight has been gotten.

After this, the indicator will automatically go to next step. If this point can't be calibrated correctly (maybe the weight load onto scale is too small, maybe the input data is incorrect...), it will display “**CAL.Er**” and return back to step12.5.1 for re-calibration.
 - 12.5.3 When **End.y** is shown and **y** is flashing, it's waiting command to exit calibration or go on next calibration. Use **PRINT** or **ACC** key to select **yes** or **no**, use **TARE** to confirm. If **yes** is selected, it will go to step12.8 to end calibration; if **no** is selected, it will go to next step.
 - 12.5.4 When 100%FS weight is displayed after **CAL.P2** being shown. It will be calibrated on standard weight for second point. Put corresponding weight (more than 10%FS weight, and larger than the weight used on **CAL.P1**) onto scale. Next operation is same as what in step12.5.2
 - 12.5.5 When **End.y** is shown and **y** is flashing, Use **PRINT** or **ACC** key to select **yes** or **no**, use **TARE** to confirm. Similar with doing in step12.5.3
 - 12.5.6 When third standard weight displayed after **CAL.P3** being shown. It will be calibrated on standard

weight for third point. Put corresponding weight (more than 10%FS weight, and larger than the weight used on **CAL.P2**) onto scale. Next operation is same as what in step12.5.2.

- 12.5.7 When the stable and reasonable data corresponding to the standard weight has been gotten. The indicator will automatically go to Step12.8. Otherwise, it will display “**CAL.Er**” and return back.
- 12.6 When **GEO** is selected, press **TARE** key to confirm to enter Geographical Adjustment
- 12.6.1 When “**CODE**” is shown, use **PRINT** or **ACC** key to select geographical position code (refer step12.6.2) or input user local gravity value directly (refer step12.6.3).
- 12.6.2 When **CODE** is selected, select the position code of scale being used (00-70) according to the elevation and latitude from Table12-1 by using **PRINT, ACC, UNIT** keys. Press **TARE** key to confirm.
- 12.6.3 When **GRAVT** is selected, Use **PRINT, ACC, UNIT** keys to input the gravity value of the position that scale is used (9.76183-9.99999). Press **TARE** key to confirm.

NOTE: Only an authorized manufacturer’s representative or certified verification personnel may make these changes. Changing the geographical setting alters the calibration values !!!

- 12.7 When **INPUT** is selected, press **TARE** key to confirm to enter Input calibration parameters value that were got before, or view current calibration parameters value.
- 12.7.1 All parameters about calibration are divided to 18 pages to be displayed on LCD by “nn:xxxx” format (“nn” is a decimal number of page, “xxxx” is an hexadecimal value of parameter, e.g. 02:85E2).
 - 01-02 pages: zero code;
 - 03-04 pages: standard weight of CAL.P1;
 - 05-06 pages: codes of CAL.P1;
 - 07-08 pages: standard weight of CAL.P2;
 - 09-10 pages: codes of CAL.P2;
 - 11-12 pages: full capacity net code;
 - 13-14 pages: the coefficient of weight fine-tune;
 - 15-16 pages: gravity value of calibration location;
 - 17-18 pages: gravity value of the location that the scale is used at.
- 12.7.2 When no digit blink on LCD, that means calibration parameters value are being viewed, and use **UNIT** key to view next page, use **ZERO** key to exit.
- 12.7.3 When parameters value are being viewed, use **DATA** key to prepare to modify, When first digit is blinked, that means the value is being modified, and you can use **UNIT** key to make next digit flash (if current flashing position is the last one, next page value will be shown), use **PRINT, ACC, UNIT** key to input number, use **TARE** key to confirm.
- 12.7.4 In this mode, press down **PRINT** key more than three seconds, these parameters will be sent out from COM1, the print out format is <LF>nn:xxxx<CR>; there’re totally eighteen lines.

12.8 After the indicator gets all need data, it will calculate and store all calibration parameters into EEPROM, or after finishing calibration works, it will display **CAL.End**. At last, it will re-start and go back to original mode.

6	0	1	2	3	4	5	6	7	8	9	10	11	12	13	14	15	16	17	18	19	20	21	22	23	24	25	26	27	28	29	30	31	32	33	34	35	36	37	38	39	40	41	42	43	44	45	46	47	48	49	50	51	52	53	54	55	56
5.8	1	2	3	4	5	6	7	8	9	10	11	12	13	14	15	16	17	18	19	20	21	22	23	24	25	26	27	28	29	30	31	32	33	34	35	36	37	38	39	40	41	42	43	44	45	46	47	48	49	50	51	52	53	54	55	56	
5.6	1	2	3	4	5	6	7	8	9	10	11	12	13	14	15	16	17	18	19	20	21	22	23	24	25	26	27	28	29	30	31	32	33	34	35	36	37	38	39	40	41	42	43	44	45	46	47	48	49	50	51	52	53	54	55	56	
5.4	2	3	4	5	6	7	8	9	10	11	12	13	14	15	16	17	18	19	20	21	22	23	24	25	26	27	28	29	30	31	32	33	34	35	36	37	38	39	40	41	42	43	44	45	46	47	48	49	50	51	52	53	54	55	56		
5.2	2	3	4	5	6	7	8	9	10	11	12	13	14	15	16	17	18	19	20	21	22	23	24	25	26	27	28	29	30	31	32	33	34	35	36	37	38	39	40	41	42	43	44	45	46	47	48	49	50	51	52	53	54	55	56		
5	3	4	5	6	7	8	9	10	11	12	13	14	15	16	17	18	19	20	21	22	23	24	25	26	27	28	29	30	31	32	33	34	35	36	37	38	39	40	41	42	43	44	45	46	47	48	49	50	51	52	53	54	55	56			
4.8	4	5	6	7	8	9	10	11	12	13	14	15	16	17	18	19	20	21	22	23	24	25	26	27	28	29	30	31	32	33	34	35	36	37	38	39	40	41	42	43	44	45	46	47	48	49	50	51	52	53	54	55	56				
4.6	4	5	6	7	8	9	10	11	12	13	14	15	16	17	18	19	20	21	22	23	24	25	26	27	28	29	30	31	32	33	34	35	36	37	38	39	40	41	42	43	44	45	46	47	48	49	50	51	52	53	54	55	56				

TABLE12-1-1: Location Code for different elevation and latitude

13. Weight Fine-tune

With this function, the user can adjust displayed weight a little, and no need standard weight. But please Note:

- (1) The scale must have been calibrated before this adjustment
- (2) The range of adjustment is “(current displayed weight) x (0.9-1.1)”. it means the range is about $\pm 10\%$
- (3) The “**CONFIG-REGULA =NONE**” and “**CONFIG-FUNC-WT.ADJ=YES**” must be set.
- (4) **Only an authorized manufacturer’s representative or certified verification personnel may make these changes. Changing this value alters the calibration values !!!**

13.1 To enter this mode, turn on indicator, after indicator displaying 0 weight, put a load (suppose: its correct weight is 1230.0lb) onto scale, then indicator will display the load’s weight, say “1234.5 lb”. Press down **TARE** and **ZERO** at same time until first digit flashes, this means indicator has entered into “weight fine-tune” mode.

13.2 Use \uparrow \downarrow \rightarrow to input correct weight (1230.0). After confirmed by **TARE**, the active correct weight will be displayed and no any digit will be flashed. After this, displayed weight will be adjusted by this ratio (1230.0/1234.5) and this ratio will keep active until next modification on it.

13.3 To remove effect of this ratio, there’re two ways: “12.3.1 way” and “12.3.2 way”

13.3.1 Do standard calibration, like in “**12.CALIBRATION**”

13.3.2 Move away weight on scale, Press **ZERO** to make 0 displayed, Put a load onto scale, a number will be displayed, suppose it’s 1230.0lb (but original number is 1234.5) ; Press down **TARE** and **ZERO** at same time until first digit flashes, this means indicator has entered into “weight fine-tune” mode.

Press \leftarrow key, the displayed weight will be restored to 1234.5, and then press \leftarrow to confirm and exit to normal weighing mode.

14. View ADC output Code

14.1 In this mode, you can examine the stability of weighing system, the increment value of ADC output code corresponding to the loaded weight.

Note:

① The increment of ADC code for FS weight must be larger or equal to 10 times of selected display division; otherwise, the calibration cannot be properly completed. e.g. The display division is 0.1kg. Load 100kg standard weight on the platform, the increment of ADC code should be at least more than $10 \times 100\text{kg} / 0.1\text{kg} = 10 \times 1000 = 10000$. In this case, the scale can be calibrated. Otherwise, smaller division needs to be Chosen.

② The variation of ADC code should be small; otherwise, the calibration cannot properly complete also.

14.2 To go to this working mode, press down **SETUP** until **CONFIG** is shown, using **PRINT** , **ACC** and **TARE** key to to go to **MISC - Code** item, press **TARE** to enter this mode and display ADC output raw code.

14.3 In this mode, first press **TARE** key can set current code as a reference zero, and then to display net code, press **TARE** again to clear this reference and display gross code.

14.4 In this mode, press **UNIT** key to select displaying code that has been filtered by no-filter, filter1 or filter1 and filter2, and corresponding annunciator **Lo**, **OK**, **HI** will be lighted.

14.5 Press **SETUP** key to return to last menu item, press **ON/OFF** key to prepare to exit this mode

15. View or Calibrate Power Voltage

15.1 In this mode, you can examine the voltage of battery, or you can examine the voltage that regulated out from AC adaptor when no battery is used, you also can calibrate the displayed voltage and set the voltage value of low battery point.

Note:

(1)The end customer normally no need to calibrate the displayed voltage, these have been done in factory.

(2) The normal displaying voltage is 4.0V-6.0V

15.2 To go to this working mode, press down **SETUP** until **CONFIG** is shown, using **PRINT** , **ACC** and **TARE** key to to go to **MISC - VoL** item, press **TARE** to enter this mode and display battery voltage.

15.3 If the voltage is sure not correct, to calibrate the voltage according to following steps:

15.3.1 Prepare a DC power supply which output voltage can be adjusted from 5V to 8V, output current must be larger than 0.5A. Power off the indicator, move away AC adaptor, Connect this DC power to battery connector on main board, adjust voltage to about 5V, power on the indicator, enter battery voltage display mode by the way of step15.2.

15.3.2 Press down **UNIT** until **CAL.5V** is shown, adjust voltage to 5V, press **TARE** key to confirm 5V calibration.

15.3.3 When **CAL.6V** is shown, adjust voltage to 6V, press **TARE** key to confirm 6V calibration. When **CV.End** is shown, that means the voltage calibration is completed and then exit to display voltage.

15.4 Press **SETUP** key to return to last menu item, press **ON/OFF** key to prepare to exit this mode

16. View or Set Time

16.1 After entering **SETUP** mode (by press down **SETUP** key more than 3s), using **PRINT** or **ACC** key to select **MISC-TIME** item, press **TARE** to display current time.

16.2 Time display Format is: xx:xx:xx(hh-mm-ss) , 24h format

16.3 Press down **UNIT** more than 3s to enter modification time mode. Using **PRINT**, **ACC**, **UNIT**, **TARE** keys to modify current time. If time of no operation is more than 5s, it will automatically exit modification mode.

16.4 Press **SETUP** key to return to last menu item, press **ON/OFF** key to prepare to exit this mode

17. View or Set Date

17.1 After entering **SETUP** mode (by press down **SETUP** key more than 3s), using **PRINT** or **ACC** key to select **MISC-DATE** item, press **TARE** to display current time.

17.2 Date display Format is: xx.xx.xx(yy-mm-dd)

17.3 Press down **UNIT** more than 3s to enter modification date mode. Using **PRINT**, **ACC**, **UNIT**, **TARE** keys to modify current date. If time of no operation is more than 5s, it will automatically exit modification mode.

17.4 Press **SETUP** key to return to last menu item, press **ON/OFF** key to prepare to exit this mode

18. View Firmware Version

18.1 Press down **SETUP** until **CONFIG** is shown, using **PRINT** or **ACC** key to select **MISC-VER** item, press **TARE** to display current Version.

18.2 Firmware Version display Format is: Vxx.yy, xx is hardware version, yy is software version

18.3 Press **SETUP** key to return to last menu item, press **ON/OFF** key to prepare to exit this mode

19. Display Test

19.1 Press down **SETUP** more than 3s to enter **SETUP** mode, using **PRINT** or **ACC** key to select **TEST-DISP.TST** item, press **TARE** to enter test display mode and all segments will be lighted first.

19.2 In this mode, every pressing of **ACC** key will light next segment, every pressing of **UNIT** will light next digit, press **PRINT** will automatically light all segments and all digits.

19.3 Press **SETUP** key to return to last menu item, press **ON/OFF** key to prepare to exit this mode

20. Keyboard and Buzzer Test

20.1 Press down **SETUP** more than 3s to enter **SETUP** mode, using **PRINT** or **ACC** key to select **TEST-key.tst** item, press **TARE** to enter test keypad mode, and **key. --** will be displayed.

20.2 In this mode, press a key, the value of this key will be displayed on -- position and buzzer will beep whatever **USER-BEEP-KEY** item is set.

20.3 Press **SETUP** key to return to last menu item, press **ON/OFF** key to prepare to exit this mode

21. Serial Port1/2 (COM1/2) Receiving Test

21.1 Before test the receiving function of **COM1** or **COM2**, a cable is need to connect a PC and this indicator, and a software be similar with Super Terminal of Windows is also need to run on PC to send bytes to this indicator. Please note: baud rate is selected by **USER-COM1/2-BAUDRT, 8N1 byte format is fixed,** Hex data (0x00 – 0xff) are used.

21.2 Press down **SETUP** more than 3s to enter **SETUP** mode, using **PRINT** or **ACC** key to select **TEST-COM1.RD** or **TEST-COM2.RD** item, press **TARE** to enter test COM1/2 receiving function, and **rd1.--** or **rd2.--** will be displayed first.

21.3 In this mode, received hex data (0x00 – 0xff) will be displayed on -- position.

21.4 Press **SETUP** key to return to last menu item, press **ON/OFF** key to prepare to exit this mode

22. Serial Port1/2(COM1/2) Transmitting Test

22.1 Before test the transmitting function of **COM1** or **COM2**, a cable is need to connect a PC and this instrument , and a software be similar with Super Terminal of Windows is also need to run on PC to receive bytes from this instrument. Please note: baud rate is selected by **USER-COM1/2-BAUDRT, 8N1 byte format is fixed,** Hex data (0x00 – 0xff) are used.

22.2 Press down **SETUP** more than 3s to enter **SETUP** mode, using **PRINT** or **ACC** key to select **TEST-COM1.TD** or **TEST-COM2.TD** item, press **TARE** to enter test COM1/2 transmitting function, and **td1.--** or **td2.--** will be displayed first.

22.3 In this mode, transmitted hex data (0x00 – 0xff) will be displayed on -- position, and **PRINT, ACC, UNIT, TARE** keys can be used to modify transmitted data.

22.4 Press **SETUP** key to return to last menu item, press **ON/OFF** key to prepare to exit this mode

23. Details about Serial Communication

23.1 COM1 is RS232, communication wires come from RS232 connector, and **TXD0**, **RXD0** and **GND** are used. Please refer to section 24.5 connector details

23.2 COM2 is USB used as a virtual RS232, communication wires come from USB connector, and **TXD1**, **RXD1** and **GND** are used, Please refer to section 24.6 for connector details.

23.3 The baud rate and byte format is set by **USER-COM1/2-BAUD.RT** and **USER-COM1/2-BYT.FMT**. Responses to serial commands will be immediate, or within one weight measure cycle of the scale. One second should be adequate for use as a time-out value by remote (controlling) device.

23.4 The length of each item in a transition string:

23.4.1 Reading data --- 6bytes

Data polarity ----1byte: “-” for negative, and followed the first digit; “ ” for positive.

Decimal point ---1byte: “.”

Measure unit ----1-5bytes:“ lb”,“ kg”,“lb:oz”,“pcs”,“%”, Units are always lower case, left aligned

Current status-- 4bytes

23.4.2 If the weight is overcapacity, the scale will return eight “^” characters (the field of polarity, decimal point, weight data is filled by “^”).

23.4.3 If the weight is under capacity, it will return eight “_” characters (the field of polarity, decimal point, and weight data is filled by “_”).

23.4.4 If the zero point is error, it will return eight “-” characters (the field of polarity, decimal point, and weight data is filled by “-”).

23.4.5 Useless leading 0 before digits is suppressed. Reading weight is right aligned.

23.5 Key to symbols used

<LF>	Line Feed character (hex 0AH)
<CR>	Carriage Return character (hex 0DH)
<ETX>	End of Text character (hex 03H)
<SP>	Space (hex 20H)
H ₁ H ₂ H ₃ H ₄	Four current status bytes
<P>	Polarity character: “-” or “ ”
W ₁ ---W ₆	Reading data, 1-6 bytes (six digits)
<DP>	Decimal point
U ₁ U ₂ U ₃ U ₄ U ₅	Measure units, kg, lb, lb:oz , % or pcs; 2-5 bytes
<Add>	Address of scale; 2 bytes (00-99)
<Prompt>	Prompt characters of output content; max. 11bytes

The bit definition of H₁H₂H₃ H₄:

Bit	Byte 1 (H1)	Byte 2 (H2)	Byte 3 (H3)	Byte 4 (H4)
0	0=stable	0= not under capacity	00=compare disable	00=normal weighing
	1= not stable	1= under capacity	01=lower limit	01=count weighing
1	0= not at zero point	0= not over capacity	10=ok	10=percent weighing
	1= at zero point	1= over capacity	11=upper limit	11=other mode
2	0=RAM ok	0=ROM ok	0= gross weight	0=not in HOLD
	1= RAM error	1=ROM error	1= net weight	1=in HOLD
3	0= eeprom OK	0=calibration ok	0=initial zero ok	0=battery ok
	1= eeprom error	1=calibration error	1=initial zero error	1=low battery
4	always 1	always 1	always 1	always 1
5	always 1	always 1	always 1	always 1
6	always 0	always 1	always 1	always 0
7	parity	Parity	parity	Parity

23.6 Communication Details when **USER-COM1/2-LAYOUT** is set to **SINGLE**:

23.6.1 Commands and response

23.6.1.1 Command: **W<CR>** (57h 0dh), request current reading

Response:

①<LF>~~~~~U₁U₂ U₃U₄U₅<CR><LF> H₁H₂H₃ H₄<CR><ETX>---over capacity②<LF>_ _ _ _ _ U₁U₂ U₃ U₄U₅<CR><LF> H₁H₂H₃ H₄<CR><ETX>---under capacity③<LF> - - - - - U₁U₂ U₃ U₄U₅<CR><LF> H₁H₂H₃ H₄<CR><ETX>---zero-point error**Note:** U₁U₂ U₃ U₄U₅ is 1,2,3 or 5 bytes according to current unit: %, kg, lb, pcs, lb:oz④<LF><P>W₁W₂W₃W₄W₅<DP>W₆ U₁U₂ U₃ U₄U₅<CR><LF> H₁H₂H₃ H₄ <CR><ETX>---normal data**Note:** (1) The decimal point position is determined by **CONFIG-PRIM.D**

(2) If current unit is "lb:oz", the format will be similar with following:

<LF><P>W₁W₂W₃**lb**<SP>W₄W₅<DP>W₆**oz**<CR><LF> H₁H₂H₃ H₄ <CR><ETX>23.6.1.2 Command: **S<CR>** (53h 0dh) , request current statusResponse: <LF> H₁H₂H₃ H₄<CR><ETX>23.6.1.3 Command: **Z<CR>** (5ah 0dh)Response: Zero function is activated (simulate **ZERO** key) and it returns to current scale status.<LF> H₁H₂H₃H₄<CR><ETX>

If ZERO function cannot be activated, it will return to current scale status.

23.6.1.4 Command: **T<CR>** (54h 0dh)Response: TARE function is activated (simulate **TARE** key), and then returns scale status.<LF> H₁H₂H₃ H₄ <CR><ETX>

If TARE function cannot be activated, it will return to current scale status.

23.6.1.5 Command: **U<CR>** (55h 0dh)

Response: Changes units of measure (simulate **UNIT** key) and return scale status with **new** units,
The new measure unit should be allowed to use

<LF> U₁U₂ U₃ U₄U₅<CR><LF> H₁H₂H₃ H₄<CR><ETX>

23.6.1.6 Command: **L<CR>** (4ch 0dh)

Response: If Hold function can be activated, it will enable/disable hold function (simulate **HOLD** key),
and returns scale status.

<LF> H₁H₂H₃H₄<CR><ETX>

23.6.1.7 Command: **X<CR>** (58h 0dh)

Response: power off the scale, just like press down the **ON/OFF** key to turn off the scale.

23.6.1.8 Command: all others

Response: Unrecognized command

<LF>? <CR><ETX>

23.6.2 Summary of Command and Response:

Command		Response
ASCII	HEX	
W<CR>	57 0d	Read scale weight: ①<LF>~~~~~U ₁ U ₂ U ₃ U ₄ U ₅ <CR><LF> H ₁ H ₂ H ₃ H ₄ <CR><ETX>---over capacity ②<LF>_____U ₁ U ₂ U ₃ U ₄ U ₅ <CR><LF> H ₁ H ₂ H ₃ H ₄ <CR><ETX>---under capacity ③<LF>----- U ₁ U ₂ U ₃ U ₄ U ₅ <CR><LF> H ₁ H ₂ H ₃ H ₄ <CR><ETX>---zero-point error ④<LF><p>W ₁ W ₂ W ₃ W ₄ W ₅ <dp>W ₆ U ₁ U ₂ U ₃ U ₄ U ₅ <CR><LF>H ₁ H ₂ H ₃ H ₄ <CR><ETX> ---normal data
S<CR>	53 0d	<LF> H ₁ H ₂ H ₃ H ₄ <CR><ETX>; read scale status
Z<CR>	5a 0d	<LF> H ₁ H ₂ H ₃ H ₄ <CR><ETX> ; simulate ZERO key
T<CR>	54 0d	<LF> H ₁ H ₂ H ₃ H ₄ <CR><ETX> ; simulate TARE key
U<CR>	55 0d	<LF> U ₁ U ₂ U ₃ U ₄ U ₅ <CR><LF> H ₁ H ₂ H ₃ H ₄ <CR><ETX>; simulate UNIT key
L<CR>	4c 0d	<LF> H ₁ H ₂ H ₃ H ₄ <CR><ETX>; simulate HOLD key
X<CR>	58 0d	power off the scale, simulate OFF key
others		<LF>? <CR><ETX>

23.7 Communication Details when **USER-COM1/2-LAYOUT** is set to **MULTIPLE**:

23.7.1 Output string frame:

<LF><Prompt><p>W₁W₂W₃W₄W₅<Dp>W₆ U₁U₂ U₃ U₄U₅<CR>

..... ---- Line number and content are determined by setting of **USER-OUT1/2-xxxx**

<LF><Prompt>H₁H₂H₃ H₄<CR> ---- **USER-OUT1/2-STATUS** is set to **YES**

.....

<LF>

(1)The decimal point position is determined by **CONFIG-PRIM.D**

(2)The unit position and bytes is determined by which current unit is used.

(3)The details of <Prompt> refer to the content in 4.3**USER Submenu**.

(4)In hold mode, if ADC conversion speed is set high speed (80Hz), and **USER-COM1/2-LAYOUT** is set to **MULTIPLE**, and many contents are selected to output, the output contents from COM1 or COM2 may not catch up with the data processed in indicator, So, if you want to watch “real time” data, you need to select fewer output contents and set higher baud rate for C<CR> --- **USER-OUT1/2-LINE** is set to **LINE1/2/3/4**

..... ---The number of blank lines is determined by **USER-OUT1/2-LINE** setting

<ETX> --- Last byte of string frame

23.7.2 Examples of some layout when **USER-OUT1/2-xxxx** is set to **YES (USER-COM2-EN.ADDR=No)**:

23.7.2.1 In weighing mode:

```
SCALE ID: 123456
GROSS:    123lb 4.56oz
TARE:     11lb 2.22oz
NET:      112lb 2.34oz
ACC. N:   8
TOTAL:    789lb 15.2oz
DATE:     2011-06-12
TIME:     12:34:56
A/D CODE: 1234567
VOLTAGE:  6.7V
STATUS:   bpq2
```

23.7.2.2 In counting mode:

```
SCALE ID: 123456
GROSS:    1234.55kg
TARE:     12.15kg
NET:      1222.40kg
QUANTITY: 24448pcs
PIECE WT: 0.05kg
ACC. N:   10
TOTAL:    23456pcs
```

DATE: 2011-06-12
TIME: 12:34:56
A/D CODE: 1234345
VOLTAGE: 6.7V
STATUS: bpq2

23.7.2.3 In percent weighing mode:

SCALE ID: 123456
GROSS: 12345lb
TARE: 10lb
NET: 12335lb
PERCENTAGE: 91.4%
1% REF. WT: 135lb
ACC. N: 3
TOTAL: 271.6%
DATE: 2011-06-12
TIME: 12:34:56
A/D CODE: 1231234
VOLTAGE: 6.7V
STATUS: bpq2

23.7.2.4 In BMI mode:

SCALE ID: 123456
GROSS: 110.0kg
TARE: 10.0kg
NET: 100.0kg
HEIGHT: 170cm
BMI : 34.6
DATE: 2011-06-12
TIME: 12:34:56
A/D CODE: 1231234
VOLTAGE: 6.7V
STATUS: bpq2

23.8 Communication Details when **USER-COM1/2-LAYOUT** is set to **EH-SCP**:

23.8.1 This protocol of serial communication is similar to TOLEDO PS60 protocol. The baud rate and data format is set by User menu.

23.8.2 Output status bit meaning:

Bit	Status Byte
0	0=Stable weight data
	1=Scale in motion
1	0= Within weighing range
	1= Over capacity
2	0=Within weighing range
	1= Under zero
3	0= Within range
	1= Outside zero capture range
4	0= Not at center of zero
	1= Center of zero
5	always 1
6	always 1
7	parity

23.8.3 Summary of Command and Response:

Command		Response
ASCII	HEX	
W	57	Read scale weight: ①normal data <STX> W ₁ W ₂ <dp>W ₃ W ₄ W ₅ <CR> ②if current weight is invalid <STX>?<Status Byte><CR>
Z	5a	Simulate ZERO key: <STX>?<Status Byte><CR> ;
L	4c	Switch to and send standard weight. Same as W above
K	4b	Switch to and send metric weight. Same as W above
others		Un-known commands: <STX>?<Status Byte><CR>

23.9 Communication Details when **USER-COM1/2-LAYOUT** is set to **SCP-12**:

23.9.1 This protocol of serial communication is similar to with NCI3835 protocol. The baud rate and data format is set by User menu.

23.9.2 Output status bit meaning:

Bit	Status Byte1	Status Byte2
0	0=Scale in motion	1 = Under capacity
	1=Stable	0 = Not under capacity
1	0= Scale at zero	1 = Over capacity
	1= Not at zero	0 = Not over capacity
2	0=RAM error	1 = ROM error
	1= RAM okay	0 = ROM okay
3	0= EEPROM error	1 = Faulty calibration
	1= EEPROM okay	0 = Calibration okay
4	Always 1	Always 1
5	always 1	always 1
6	always 0	always 0
7	parity	parity

23.9.3 Key to symbols used:

- <ETX> End of TeXt character (03 hexadecimal).
- <LF> Line Feed character (0A hex).
- <CR> Carriage Return character (0D hex).
- Xxxxxx Weight characters from display including minus sign and out-of-range characters.
- p Polarity character (ie '-' for negative, space for positive)
- hh Two status bytes. (see 23.9.2)
- UU Units of measure (LB, KG or OZ all upper case).

23.9.4 Summary of Command and Response:

Command		Response
ASCII	HEX	
W<CR>	57 0D	Returns decimal lb, kg or oz weight, units and status. <LF>pxxx.xxUU<CR>hh<ETX> Returns ounces weight with units plus scale status. <LF>p00xxxxxOZ<CR>hh<ETX> Scale status only if initial zero error. <LF>hh<CR><ETX>
S<CR>	53 0D	Read scale status : <LF>hh<CR><ETX>
Z<CR>	5A 0D	Simulate ZERO key: no response from scale.
others		Un-known commands: <LF>?<CR>

23.9.5 If your indicator need work with UPS worldship, you can try following settings:

- (1) USER-COM1(or 2)-BAUD.RT=4800
- (2) USER-COM1(or 2)-BYT.FMT=7E1
- (3) USER-COM1(or 2)-LAYOUT=SCP-12
- (4) Set scale port to NCI3835 in UPS worldship.

24. Bluetooth Configuration

- 24.1 This section is need be referenced only when Bluetooth module is installed and selected in configuration parameters and user parameters. More information refer to section “4.7 BT submenu”
- 24.2 If the scale or indicator is a new one or Bluetooth module is replaced, or transmitter and receiver can not be linked to each other, the Bluetooth module should be re-configured. Go to setup mode, select “BT”, then press **TARE** to confirm to enter Bluetooth initialization or modification mode. However, if no need, don't do this, because every initialization or modification will erase and write some FLASH memory units and there's a limitation on FLASH memory erase-write times
- 24.3 When indicator displays “bt..?”, it means asking whether step into Bluetooth initialization operation, Pressing **TARE** to confirm and go to the next step, press **ON/OFF** to exit this state.
- 24.4** When indicator displays “Init”, it means asking whether initialize the Bluetooth parameters, pressing **TARE** to confirm and go to initialize, Press **PRINT/ACC** key to go to last or next item, press **ON/OFF** to exit .
- 24.5 When indicator displays “Init.i” (i=1/2/3/...), it means that the Bluetooth initialization has gone to step i . Pressing **ON/OFF** to exit, if the initialization is completed correctly, it will go to the next step automatically.
- 24.6 After indicator finish initialization, it will back to show “INIT”.
- 24.7 When indicator displays “LAdd”, it means asking whether showing the Local Bluetooth Address, press **TARE** to confirm and go into next step, Press **PRINT/ACC** key to go to last or next item, press **ON/OFF** to exit.
- 24.8 When indicator displays “Li.xxxx”(i=1/2/3), it means the indicator is showing the local Bluetooth address from high to low in cycle, totally twelve Hexadecimal digits will be shown. Press **UNIT** key to view next page; use **ON/OFF** key to exit.
- 24.9 When indicator displays “rAdd”, it means asking whether to show the remote Bluetooth address, press **TARE** to confirm and go into next step, Press **PRINT/ACC** key to go to last or next item, press **ON/OFF** to exit.
- 24.10 When indicator displays “ri.xxxx” (i=1/2/3, it means the indicator is showing the remote Bluetooth address from high to low in cycle, totally twelve Hexadecimal digits will be shown.

The remote address should be same as the transmitter's Bluetooth address. Otherwise, indicator cannot establish the data transmission channel with the transmitter. And Initialization should be done to clear the address. Press **UNIT** key to view next page; use **ON/OFF** key to exit.

If you want input remote blue tooth address, long press **DATA** key to enter input address mode, then use **PRINT, ACC, UNIT, TARE** ...to input address.

- 24.11 When indicator displays “BAUD” , that means it is prepared to set or view the communication baud rate. Press **TARE** to confirm entering view or modification. The “BAUD” will be flashed. After enter this mode, the original baud will be displayed first, then use **PRINT** and **ACC** to change baud rate to 1200, 2400, 4800, 9600, 19200 or 38400, use **TARE** to confirm the selection, and The selected baud rate will be flashed, after your selection is saved, it is back to display “BAUD”.
- 24.12 When indicator displays “UARTMD” , that means it is prepared to set or view communication format. Press **TARE** to confirm entering view or modification. The “UARTMD” will be flashed. After enter this mode, the original format will be displayed first, then use **PRINT** and **ACC** to select communication

format from 8N1, 7E1, 7E2, 7O1 and 7O2, use **TARE** to confirm the selection. After your selection is saved and it stop flashing, it back to display “UARTMD”

- 24.13 When indicator displays “PASSWD” , that means it is prepared to set or view blue tooth password. Press **TARE** to confirm entering view or modification of password. The “PASSWD” will be flashed. After enter this mode, the original password will be displayed first, then use **PRINT**, **ACC** and **UNIT** to change password, use **TARE** to confirm your input. If **PRINT** and **ACC** is pressed down over 3 seconds, the character (0-9, A-Z) on modified position will be changed in fast speed. After your input is saved and it stop flashing, it back to display “PASSWD”
- 24.14 When indicator displays “TYPE”, that means it is prepared to set or view blue tooth working type. Press **TARE** to confirm entering view or modification of working type. The “TYPE” will be flashed. After enter this mode, the original working type will be displayed first, then use **PRINT** and **ACC** to select working type from 0=slave, 1=master, 2=repeater and 3=relay node, use **TARE** to confirm your selection. After your selection is saved and it stop flashing, it back to display “TYPE”
- 24.15 When indicator displays “ROLE” that means it is prepared to set or view the role of the blue tooth. Press **TARE** to confirm entering view or modification of role. The “ROLE” will be flashed. After enter this mode, the original blue tooth role will be displayed first, then use **PRINT** and **ACC** to select role of blue tooth from 0=slave and 1-7=master that it can connected to 1-7 slave device. Use **TARE** to confirm the selection. After your selection is saved and it stop flashing, it back to display “ROLE”
- 24.16 When indicator displays “MAXCON” that means it is prepared to set or view the maxim number of the blue tooth device can connect to. Press **TARE** to confirm entering view or modification of this number. The “MAXCON” will be flashed. After enter this mode, the original maxim number of blue tooth can connect will be displayed first, then use **PRINT** and **ACC** to modify this number to 0-7, use **TARE** to confirm input. After your input is saved and it stop flashing, it back to display “MAXCON”
- 24.17 When indicator displays “BIND” that means it is prepared to set or view whether the address of the blue tooth bind. Press **TARE** to confirm entering this mode. The “BIND” will be flashed. After enter this mode, the original blue tooth bind status will be displayed first, then use **PRINT** and **ACC** to set or clear bind address of blue tooth, 0=not bind and 1=bind, use **TARE** to confirm the selection. After your selection is saved and it stop flashing, it back to display “BIND”
- 24.18 When indicator displays “CLRADR” that means it is prepared to clear all memorized address of blue tooth. Press **TARE** to confirm, when it’s clearing, the “CLRADR” will be flashed, and stop flashing after cleared. After your all memorized address are cleared and it stop flashing, it back to display “CLRADR”
- 24.19 When indicator displays “BTVER” that means it is prepared to view the version of blue tooth module. Press **TARE** to confirm. The “BTVER” will be flashed. After enter this mode, the blue tooth module version will be displayed. Press **ON/OFF** to exit.
- 24.20 In the above steps, if indicator displays “bt.Err”, that means the Bluetooth can’t be initialized or can’t get information from Bluetooth. Press **TARE** to go to next step, try to re-start, or press **ON/OFF** to give up operation, exit this mode, and power off indicator, then power on again and try initialization or modification again.
- 24.21 If receiver and transmitter can’t link each other, make sure above settings are proper, or try doing an initialization; or try power off and then power on it again. If the transceiver interrupts some time, try to adjust the antenna direction (if the antenna is external). As shown below.

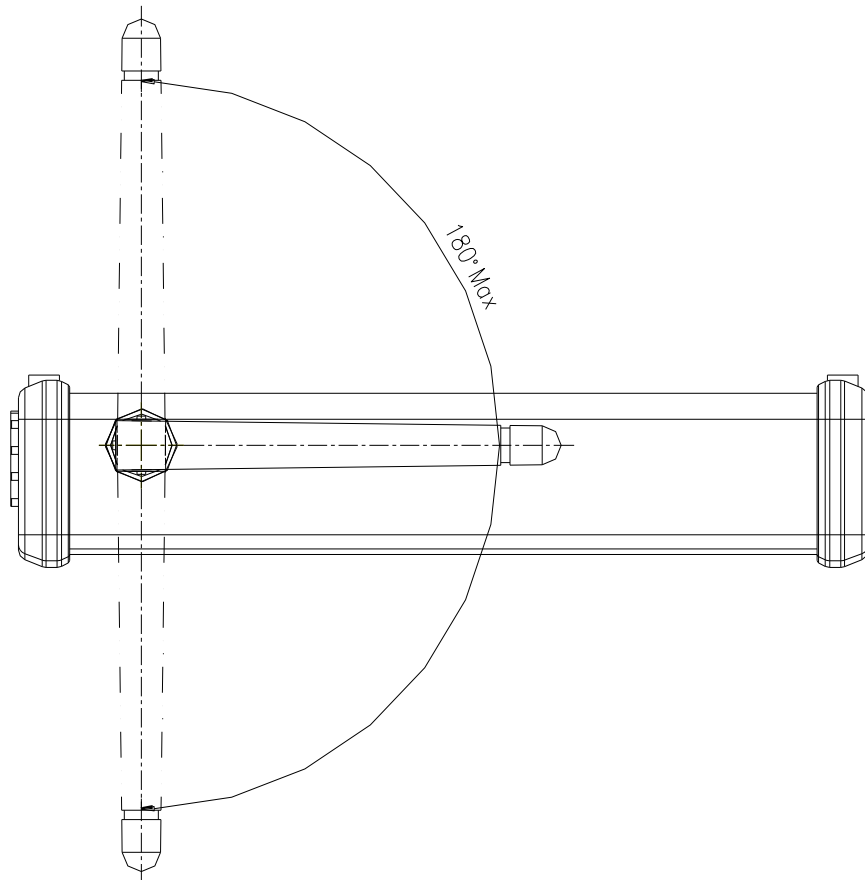
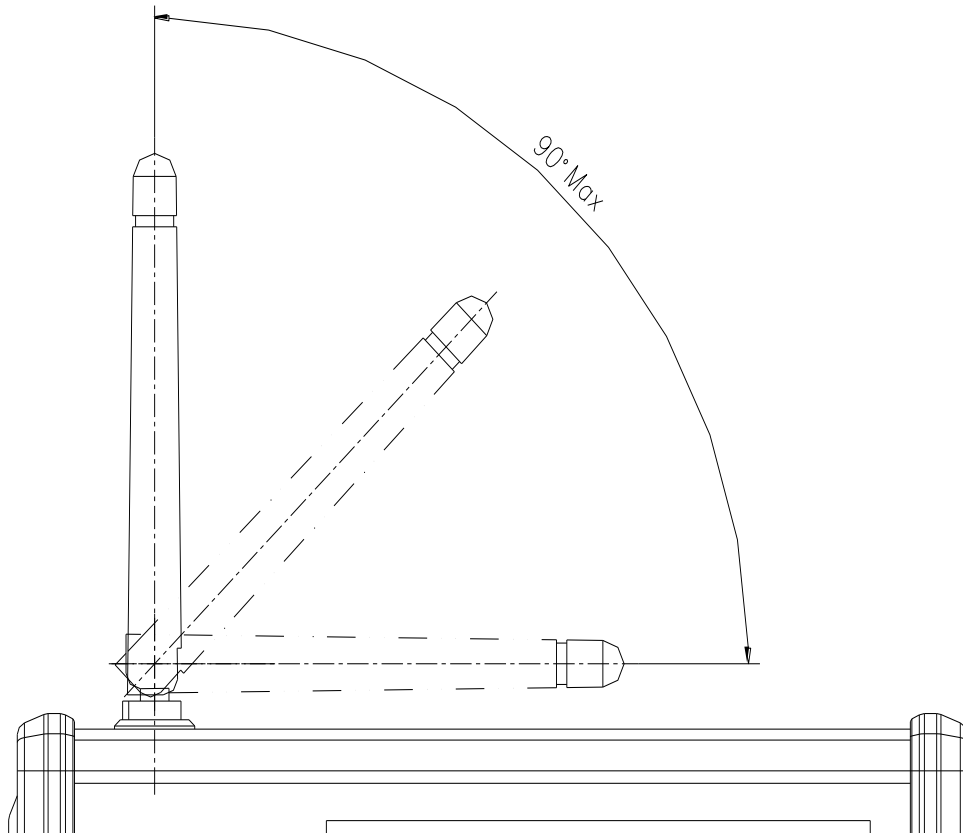

25. Connectors and Jumpers

25.1 Overview of Connectors or jumpers on PCB

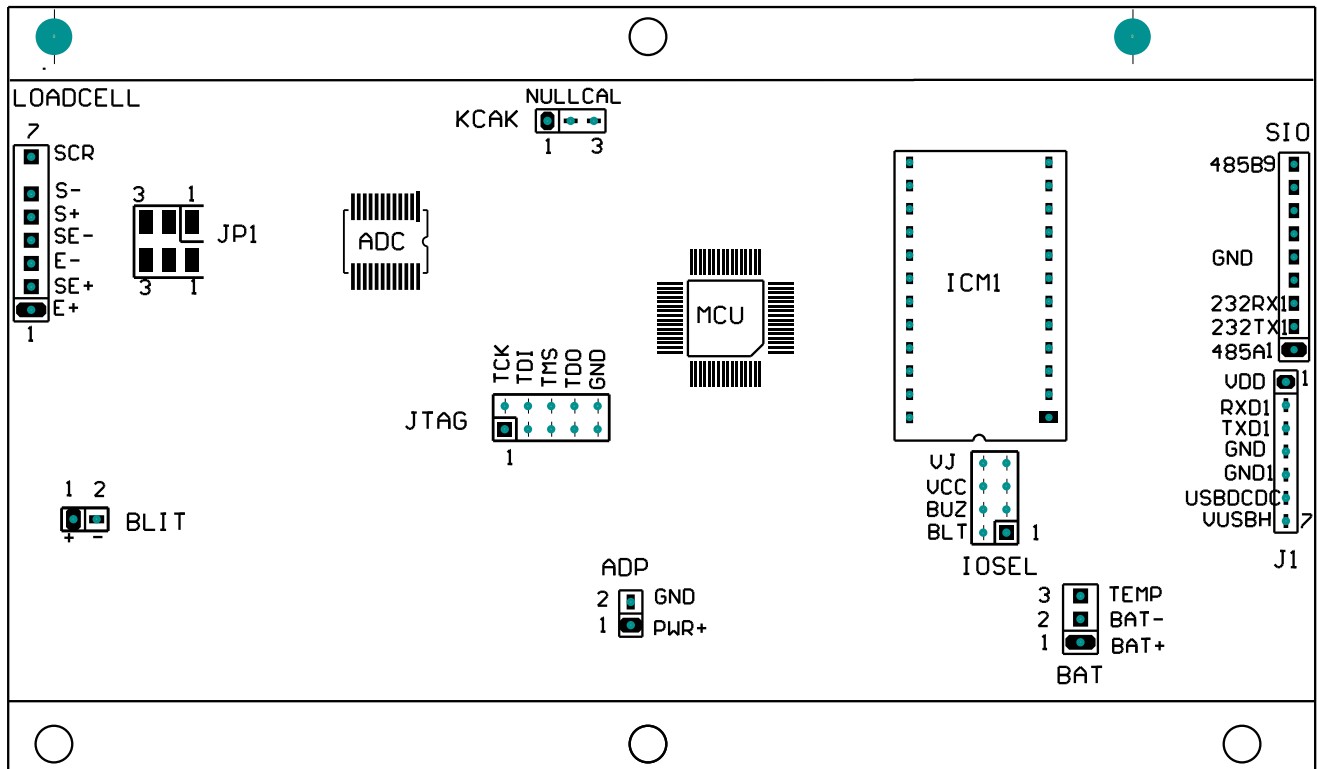

25.2 Load Cell Connector

PIN #	DEFINITION	IN/OUT/POWER	ELECTRICAL LEVEL
1	Excitation +	Power output	$5 \pm 0.3 \text{ Vdc}$ ($\leq 0.12\text{A}$)
2	Sense +	Power input	$5 \pm 0.3 \text{ Vdc}$
3	Excitation-	Power ground	0Vdc
4	Sense -	Power input	$\leq 0.5 \text{ Vdc}$
5	Signal +	Signal Input	$2.5 \pm 0.3 \text{ Vdc}$
6	Signal -	Signal Input	$2.5 \pm 0.3 \text{ Vdc}$
7	Shield	-	-

25.3 ADP---adapter power input connector

PIN #	DEFINITION	IN/OUT/POWER	ELECTRICAL LEVEL
1	Adapter input voltage +	Power input	7-9Vdc ($I \geq 0.5\text{A}$)
2	Adapter input voltage – (GND)	Power ground	0Vdc

25.4 BAT---Battery power input Connector

PIN #	DEFINITION	IN/OUT/POWER	ELECTRICAL LEVEL
1	Battery input voltage +	Power input	4-6.8Vdc
2	Battery input voltage – (GND)	Power ground	0Vdc
3	Temperature sensor on Battery input	Power ground	

25.5 SIO---Serial Input Output Connector

PIN #	DEFINITION	IN/OUT/POWER	ELECTRICAL LEVEL
1	RS485 signal A (if RS485 installed)	Input/output	0-5Vdc
2	RS232 Transmit on COM1	Output	-12 to +12Vdc
3	RS232 Receive on COM1	Input	-12 to +12Vdc
4			
5	GND	Power ground	0Vdc
6			
7			
8			
9	RS485 signal B (if RS485 installed)	Input/output	0-5Vdc

25.6 J1---USB Connector for virtual RS232 #1 and USB power supply

PIN #	DEFINITION	IN/OUT/POWER	ELECTRICAL LEVEL
1	VDD	Power output	5 ± 0.3 Vdc
2	RXD Receive on COM2	Input	0-5Vdc
3	TXD Transmit on COM2	Output	0-5Vdc
4	GND of VDD	Power ground	0Vdc
5	GND1 of VUSBH	Power ground	0Vdc
6	USB Power DC/DC select	Output	0-5Vdc
7	USB Power DC/DC output	output	6 ± 0.3 Vdc

25.7 KCAK Jumper set:

CONNECTED PINS	FUNCTION
1-2	Calibration Disabled
2-3	Calibration Enabled

25.8 JP1 Jumper:

CONNECTED PINS	FUNCTION
1-2	Two shorter on pin1-2: 4 wires Load cell is used
2-3	Two shorter on pin2-3: 6 wires load cell is used

25.8 ICM1 Socket: used for optional Bluetooth, RS485 or USB interface

25.9 JTAG and IOSEL used by Manufacture

26. Meaning of Some Symbols and Troubleshooting

26.1 Meaning of Symbols:





































- 26.1.1 **0**----- ----- Zero is over the setting range
- 26.1.2 **0**----- ----- Zero point is below the setting range
- 26.1.3 **Ad**----- ----- Signal to ADC is over max. range)
- 26.1.4 **Ad**----- ----- Signal to ADC is below min. range
- 26.1.5 ----- ----- Weight is over upper limitation, or display data is over limitation
- 26.1.6 ----- ----- Weight is below lower limitation
- 26.1.7 **EEP.E1** ----- CONFIG or CAL parameters are not correctly set
- 26.1.8 **EEP.E2** ----- USER parameter is not correctly set
- 26.1.9 **Lo.bAt** ----- Battery voltage is lower than setting.
- 26.1.10 **CAP.- - -** ----- Next displaying content is Capacity
- 26.1.11 **CAP.ER** ----- Parameters about Capacity is not correct
- 26.1.12 **CAL.Px** ----- Calibration on point(x)
- 26.1.13 **CAL.OFF** ----- Calibration Seal Switch is on OFF position
- 26.1.14 **CAL.ON** ----- Calibration Seal Switch is on ON position
- 26.1.15 **CAL.ER** ----- Calibration error, maybe input data or loaded weight is incorrect, unstable, un-linear
- 26.1.16 **CAL.End** ----- Calibration is end
- 26.1.17 **OFF** ----- Power OFF the indicator
- 26.1.18 **STB.ER** ----- Unstable time is lager than setting of USER-HOLD-STB.TIM
- 26.1.19 **AC.xxxx** ----- Accumulation times is xxxx
- 26.1.20 **PR.TARE** ----- To Preset TARE weight
- 26.1.21 **COMP** ----- To go to input COMPARE data mode
- 26.1.22 **HIGH** ----- To input HIGH limitation data of Comparison
- 26.1.23 **LOW** ----- To input LOW limitation data of Comparison
- 26.1.24 **SPL.Lo** ----- Sample load weight of low point.
- 26.1.25 **SPL.HI** ----- Sample load weight of high point.
- 26.1.26 **SPL.PWT** ----- Sample goods weight to calculate piece weight
- 26.1.27 **INP.PCS** ----- input pieces number of weighted goods
- 26.1.28 **UNIT.KG** ----- Unit kg is selected
- 26.1.29 **UNIT.LB** ----- Unit lb is selected
- 26.1.30 **PWT.ER** ----- Piece weight is error, it's too small (<0.5d).
- 26.1.31 **SPL.PCT** ----- Sample goods weight to calculate
- 26.1.32 **INP.PCT** ----- input percentage of weighted goods
- 26.1.33 **PCT.ER** ----- Unit-Percentage -Weight is too small (<0.5d).
- 26.1.34 **CACU.ER**-----Internal calculation overflows

26.2 Troubleshooting

SYMPTOM	PROBABLE CAUSE	REMEDY
Ad-----	Load cell wires to indicator are incorrectly connected, or shorted, or opened; or ADC, load cell are damaged	Make sure wires are ok and correctly connected. Replace load cell or ADC chip, Service required.
Ad-----		
0-----	Weight reading exceeds Power On Zero limit.	Make sure scale platform is empty. Perform zero calibration.
0-----	Weight reading below Power On Zero limit.	Install platform on scale. Perform zero calibration.
-----	Weight reading exceeds Overload limit, or The weight value cannot be displayed in the current unit of measure because it exceeds 6 digits..	Reduce load on scale until weight value can be displayed. Use a more appropriate unit of measure. Re-set some parameters of CONFIG or UAER.
-----	Weight reading below Under load limit.	Install platform on scale. Perform zero calibration
EEPE1	CONFIG or CAL parameters are not correctly set	Re-set items in CONFIG, do calibration
EEPE2	USER parameter is not correctly set	Re-set items in USER
CAP.ER	Capacity parameters are not correct	Set PRIM.N/PRIM.d/SECND.n to correct number, make sure capacity not more than 6 digit
CAL.ER	Calibration error, maybe input data or loaded weight is too small, too big, unstable, un-linear	Input correct data, load correct weight onto platform, Service required
PWT.ER	Piece weight is error, it's too small (<0.5d), The weight on the platform is too small to define a valid reference weight.	Use a greater weight for the sample.
PCT.ER	<u>Unit-Percentage -Weight</u> is error, it's too small (the weight of 1%, 0.1%, or 0.01% determined by CONFIG-FUNC-PERCNT is less than 0.5d)	Use a greater weight for the sample.

CACU.ER	Internal calculation overflow	Adjust the value of the PWT or PCT
STB.ER	USER-HOLD-STB.TIM is too short, USER-HOLD-HLD.RNG is too small, other failure	Set USER-HOLD-STB.TIM longer, or set USER-HOLD-HLD.RNG bigger. Service required
Not turn on.	Power cord not plugged in or properly connected. Power outlet not supplying electricity. Battery discharged. Other failure.	Check power cord connections. Make sure power cord is plugged into the power outlet. Check power source. Replace batteries. Service required.
Cannot zero the display or will not zero when turned on.	Load on scale exceeds allowable limits. Load on scale is not stable. Load cell damage.	Remove load on scale. Wait for load to become stable. Service required.
Cannot display weight in desired weighing unit.	Unit not set to enable, or d≥5oz,when unit is lb:oz	Enable unit in CONFIG-UNITS
Battery symbol is empty or Lo.bAt is shown	Batteries are discharged.	Charge batteries

27. Display Character

ASCII	LCD/LED Show	ASCII	LCD/LED Show	ASCII	LCD/LED Show
0		A		N	
1		B		O	
2		C		P	
3		D		Q	
4		E		R	
5		F		S	
6		G		T	
7		H		U	
8		I		V	
9		J		W	
		K		X	
		L		Y	
		M		Z	

28. Packing List

No.	CONTENT	QTY
1	Indicator	1
2	User manual	1
3	Swivel bracket	1
4	1x CR2032 battery for RTC	1
5	AC Adapter	1
6	RS232 cable	Optional
7	USB interface	Optional
8	USB cable	Optional
9	Wireless (Bluetooth) Module	Optional
10	4xAA Alkaline batteries	Optional (only one can be chosen)
	4xAA NIMH batteries package	

29. Version History

VERSION	DESCRIPTION	DATE
V1.0	Initial version	2011-09-21
V1.1	(1)Add Geographical Adjustment in Calibration (2)Add Description for Connectors and Jumpers on PCB in Section24	2011-10-07
V1.2	(1)Add Fig. of load cell wire go to indicator from bottom (2)Modify 1.6.5.1 section, add 1.11.5 and 1.13.11 (3)Modify “ 3. Summary of Key function ”, add BMI key function (4)Modify 4.5 MISC-VOL ; 4.6TEST (5)Add “ 8. BMI Working Mode ” (6)Modify the content in TABLE12-1 (7)Modify “ 15. Display and Calibrate Power Voltage ” (8)Modify 23.1 and 23.2 in “ 23. Details about Serial Communication ” (9)Add 23.8 section about EH-SCP	2011-12-6
V1.3	(1)Modify some default setting in configuration and user parameters (2)Modify power supply to 7-9V,500mA; (3)Modify the max number of load cell that can be powered to 4 (x350Ω)	2012-1-14
V1.4	(1) Delete BMI faceplate in “2.Faceplate” (2) Delete BMI key in “3.Summary of key function” (3) Delete “1.6.5.3 4 holes socket used”	2012-3-14
V1.5	(1) Modify the range of zero tracking and center of zero point (2) Add prompt for the prohibition of lb:oz and HOLD for trade application	2012-05-15
V2.0	(1) Add unit “g” and “oz” and modify CONFIG-UNITS item and modify Table5-1/2 in section5.12 (2) Add “change weight unit” in calibration in section12.5.2 (3) Add contents about Bluetooth module, in section24	2012-6-15
V04.11	(1) Add more controlling of Bluetooth for end user (2) Add 7O2 & 7E2 selection in USER-COMx-BYT.FMT menu (3) Add serial communication protocol SCP-12 of NCI3835 (4) Modify EH-SCP serial communication protocol (5) Delete displaying indicator version, voltage, when power on	2013-08-02
V04.12	(1) Add calibration parameters print out function in calibration section (2) Modify the operation of accumulation	2013-08-06