

THS

HANGING SCALE



Totalcomp THS Digital Hanging Scale

An economical hanging scale for general purpose weighing.

- ✓ **Peak Hold capture**
- ✓ **Bright 25mm LCD display, large view area**
- ✓ **Displays Lb and Kg units of measure**
- ✓ **200% Safety overload**
- ✓ **Rugged housing with keypad operation**
- ✓ **Uses (3) AA batteries**



Totalcomp[®] Scales & Components

THS Hanging Scale

The Totalcomp THS digital scale is an economical weighing solution for general purpose weighing. The THS is available in four capacities with a measurement accuracy of 0.2% full scale. The scale features an easy-to-read LCD display that indicates measured values in either pounds (lbs) or kilograms (kgs). The scale can display the peak hold. You may tare weight up to 10% of the scale's rated capacity. Operation is simple using the integral membrane-style keypad. The THS is powered using (3) AA (1.5V) alkaline batteries. You may setup the scale to automatically turn power off after 3 minutes or 10 minutes of inactivity.

Specifications:

Accuracy:	0.2% of full scale
Tare:	10% of rated capacity
Safe Overload:	200% of rated capacity
Display:	25mm LCD display
Display Rate:	10Hz
Resolution:	2000:1
Data Sampling Rate:	25Hz
Power:	4.5V (with (3) 1.5V "AA" batteries)
Key Pad:	Membrane-style (On/Off, Hold/Units, Tare/Zero)
Operating Temperature:	32° to 104°F (0° to 40°C)
Storage Temperature:	-4° to 104°F (-20° to 40°C)
Shipping Weight:	3 lbs

Capacity:

Model	Capacity	Capacity
THS-22	22 lb x 0.02 lb	10kg x 10g
THS-44	44 lb x 0.01 lb	20kg x 10g
THS-88	88 lb x 0.02 lb	40kg x 20g
THS-220	220 lb x 0.1 lb	100kg x 50g
THS-440	440 lb x .2 lb	200kg x 100g

Standard Accessories:

Top holding loop, Bottom S-Hook, (3) 1.5V "AA" batteries, User guide

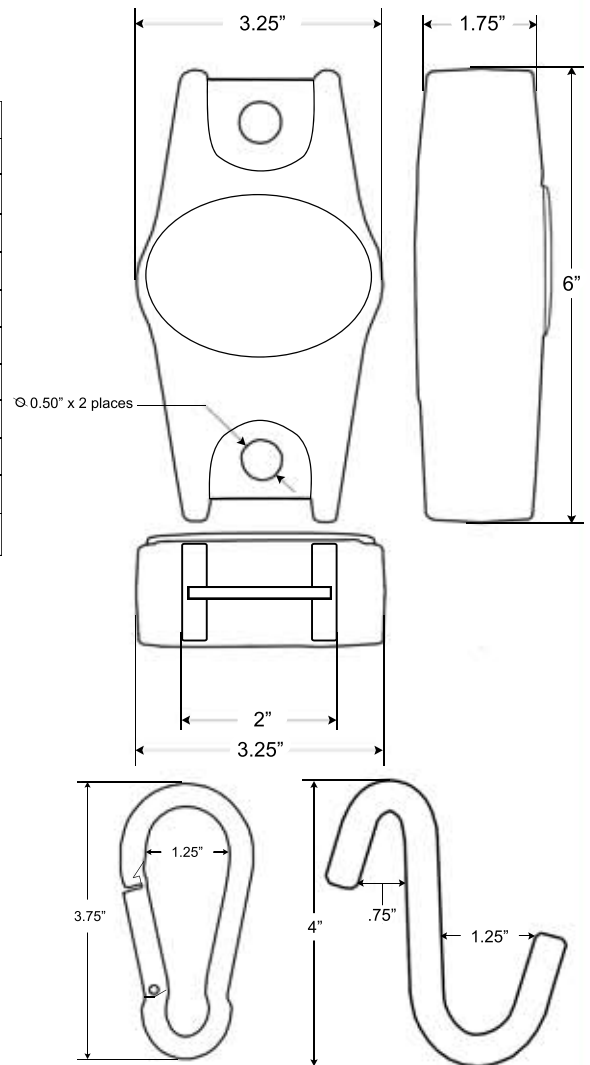

TOTALCOMP LIMITED WARRANTY

Totalcomp warrants this product to be free of defects in materials and/or workmanship and suitable for the purpose(s) intended as outlined on this sheet. This warranty is effective and shall cover the purchaser for one year from the date of shipment from our plant. If this product is found to be defective by our inspection in accordance with the above listed criteria, we will replace or repair it at our expense. For warranty service, please obtain a return authorization number from us and return the item, shipping prepaid, with a written description of the problem. We will respond promptly with the results of our evaluation.



Totalcomp[®]

Scales & Components

99 Reagent Lane
 Fair Lawn, NJ 07410
 Fax (201) 797-2287
 Toll Free Fax (888) 797-2288
 Phone (201) 797-2718
 Toll Free Phone (800) 631-0347
 Email sales@totalcomp.com
 Website www.totalcomp.com