

TPB Totalcomp



Technical Manual

CONTENTS

1. INTRODUCTION.....	1
2. SPECIFICATIONS.....	2
3. INSTALLATION.....	3
3.1 General installation.....	3
3.2 Installation of TPS series.....	3
3.2.1 Install handle.....	3
3.2.2 Adjust release device.....	4
4. PALLET TRUCK OPERATE.....	5
4.1 Control lever.....	5
4.2 Safety note.....	5
4.3 Maintenance.....	6
4.3.1 Oil.....	6
4.3.2 How to expel air from the pump unit.....	6
4.3.3 Daily check and maintenance.....	6
4.3.4 Lubrication.....	6
5. KEY DESCRIPTIONS.....	7
Display	8
6. OPERATION.....	9
6.1 Basic Operation.....	9
1. Power On /Off.....	9
2. Zero.....	9
3. Tare.....	9
4. Weighing Operation.....	9
5. Gross / Net Change.....	10
6.2 Check Weighing.....	10
6.2.1 Set Limits.....	10
6.2.2 Set Check Weighing.....	11
6.3 Accumulation.....	11
6.3.1 Memory Recall.....	11
6.3.2 Memory Clear.....	12
6.3.3 Automatically Accumulation.....	12
6.4 Animal Weighing.....	12
6.5 Key Board Lock.....	12

6.6 Set Auto Power Off.....	13
6.7 Set Back Light.....	13
7. PARAMETERS.....	14
8. CALIBRATION.....	16
APPENDIX2 DRAWING OF PUMP ASSEMBLY AND HANDLE.....	17
APPENDIX3 DRAWING OF FRAME.....	19

1. INTRODUCTION

The TPB series of pallet scale provides an accurate, fast weighing solution for pallet truck.

There are 4 series scales within the range, with 2 different fork size and optional built-in min printer.

All the keypads are mechanical switches and the displays are large easy to read liquid crystal type displays (LCD). The LCD's are supplied with a backlight.

All units include automatic zero tracking, weighing unit change, gross/net change and an accumulation facility that allows the individual weights to be stored and recalled as an accumulated total.

2. SPECIFICATIONS

Model	TPB
Max Lifting weight	5000 lbs
Min. Fork Height	85mm
Max. fork height	200mm
Fork length	1135mm
Fork overall width	555mm/688mm
Individual fork width	180mm
Capacity	5000 lbs
division	1lb
External resolution	1/5,000
Internal resolution	1/600,000
Stabilisation Time	1 Seconds typical
Operating Temperature	-10°C - 40°C / 14°F - 104°F
Calibration	Automatic External
Display	6 digits LCD digital display with 52mm high digits (EL backlight)
Interface	RS-232 Output Optional
Load cells	4 load cells

3. INSTALLATION

3.1 General Installation

Avoid extremes of temperature. Do not place in direct sunlight or near air conditioning vents.

Avoid high humidity that might cause condensation. Avoid direct contact with water. Do not spray or immerse the scales in water.

Keep the scales clean.

Do not stack material on the scales when they are not in use.

Please ascent the pallet before read weight data.

Please don't read data when pallet truck moving.

Please charge battery to full before use, see detail in SECTION 9.

3.2 Installation of TPB series

3.2.1 Install handle

The handle is packing separate from pallet truck.



1. Loosen the setting screw (140H) on the crank link (139H).
2. Remove three screws (H109) and three spring washers (H110) from the base (103).
3. Place the handle (H101) on the base (103), please note: Feed the rod and chain (H107) through the centre of the base (103) and axle (109).

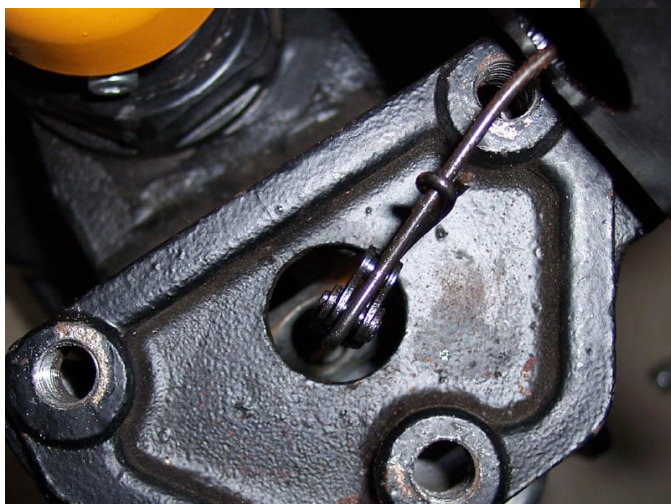

4. Insert three screws (H109) with spring washers (H110) into the base (103). Then tighten them securely.
5. Raise the crank link (139H) and put the pin on rod and chain (H107)

into the groove of crank link (139H).

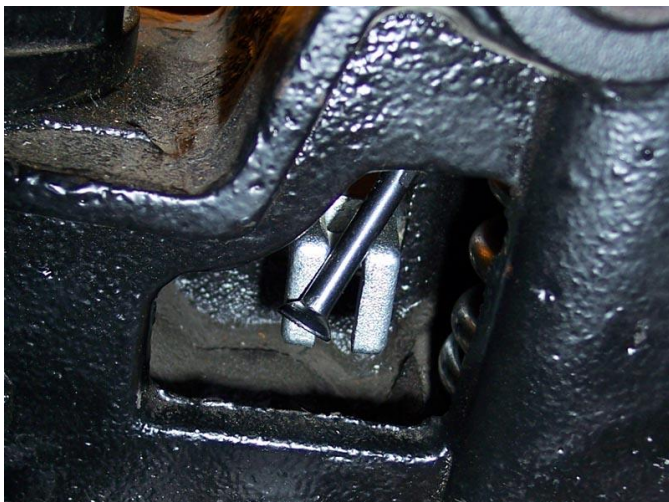

3.2.2 To adjust release device

On the handle of the pallet truck, you will find the control lever (H106) which can be set in three positions

1. First tighten the setting screw (140H) on the crank link (139H) until the LOWER position function works.

2. If the forks elevate while pumping in the NEUTRAL position, turn the setting screw (140H) clockwise until pumping the handle

does not raise the forks and the NEUTRAL position functions correctly.

3. If the forks descend while pumping in the NEUTRAL position, turn the setting screw (140H) counter-clockwise until the forks do not lower.

4. If the forks do not descend when the control lever (H106) is in the LOWER position, turn the setting screw (140H) clockwise until raising the control lever (H106) lowers the forks. Then check the NEUTRAL position as per item 2 and 3.

5. If the forks do not lift while pumping in the ASCENT position, turn the setting screw (140H) counter-clockwise until the forks elevate while pumping in the ASCENT position. Then check the NEUTRAL and LOWER position as per item 2, 3 and 4.

4. PALLET TRUCK OPERATION

4.1 CONTROL LEVER

the control lever (H106) which can be set in three positions

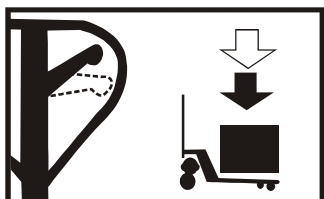

LOWER: to lower the forks



NEUTRAL: to move the load

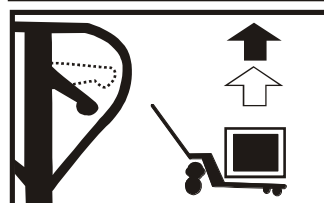

ASCENT: to raise the forks. After assembling the handle, you can adjust the three positions.

4.2 SAFETY NOTE

For safe operation of the truck, please read all warning signs and instructions here and on the truck before using this truck.

1. Do not operate the pallet truck unless you are familiar with it and have been trained or authorized to do so.
2. Do not operate the truck unless you have checked its condition. Give special attention to the wheels, the handle assembly, the forks, lift and the lower control.
3. Do not use the truck on sloping ground.
4. Never place any part of your body in the lifting mechanism or under the forks or load. Do not carry passengers.
5. The operator had better take on wear gloves and security shoes for labor protecting.
6. Do not handle unstable or loosely stacked loads.
7. Do not overload the truck.
8. Do not subject to unbalanced load, either side to side or along the length of the frame

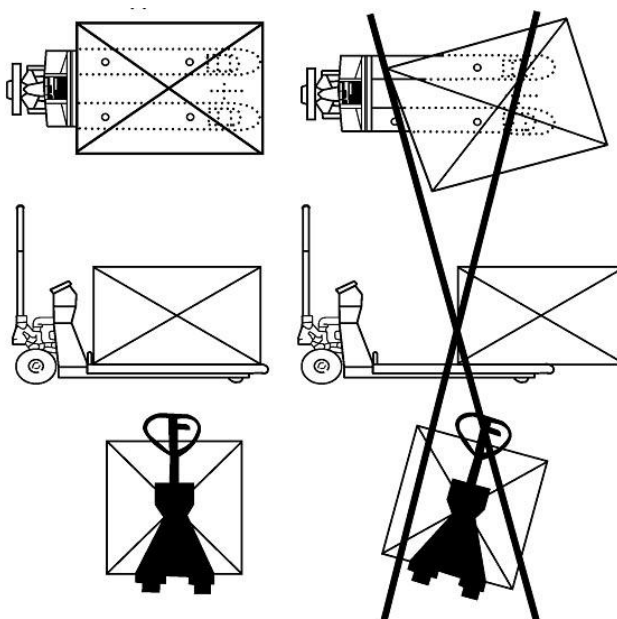

9. The capacity of the truck assumes an evenly distributed load with the centre of the load being at the halfway point of the length of the forks.
10. Make sure that length of the forks matches the length of the pallet.
11. Lower the forks to lowest height when the truck is not being used.
12. At other specific conditions or places, the operator should be carefully to operate the pallet truck.

4.3 MAINTENANCE

4.3.1 OIL

Please check the oil level every six months. The volume of oil is about 0.3lt. Use the hydraulic type oil according to temperature scale below.

Temperature	Oil
-5°C~+45°C	L-HM68 Hydraulic oil (equivalent to ISO VG68)
-15°C~-5°C	L-HM46 Hydraulic oil (equivalent to ISO VG46)



4.3.2 HOW TO EXPEL AIR FROM THE PUMP UNIT

The air may come into the hydraulic because of transportation or pump in upset position. It can cause that forks do not elevate while pumping in the ASCENT position. The air can be banished in the following way: Let the control lever (H106) to the LOWER position, then move the handle (H1501) up and down for several times.

4.3.3 DAILY CHECK AND MAINTENANCE







Daily check of the pallet truck can limit wear as much as possible. Give special attention to the wheels (127, F116 or F117), the axles (F114, F118, F121, F122), the handle (H101), the forks (F110) and lift and lower control. The forks should be unloaded and lowered in the lowest position when the job is over.

4.3.4 LUBRICATION



Use motor oil or grease to lubricate all moveable parts.



5. KEYS DESCRIPTION

Key Board

Keys	Description
	Power turn ON/OFF
	Set the Zero Display
	To perform a tare function, Subtracts weights.
	Memory recall key, show the stored values from the memory
	Accumulator key, current values will store to the memory Send the data to a printer or PC
	To select the weigh unit. (Kg, g, lb., oz., lb. oz.)
	Shift to Gross / Net Weight. To change Unit hold three seconds.

Secondary functions of the keys

Function	Keys
To confirm the selected menu	
To change the menu and active digit	
To move the active digit to right	

To move the active digit to left	
To enter in to the setting menu	
Escape from the menu to normal operation.	

Display

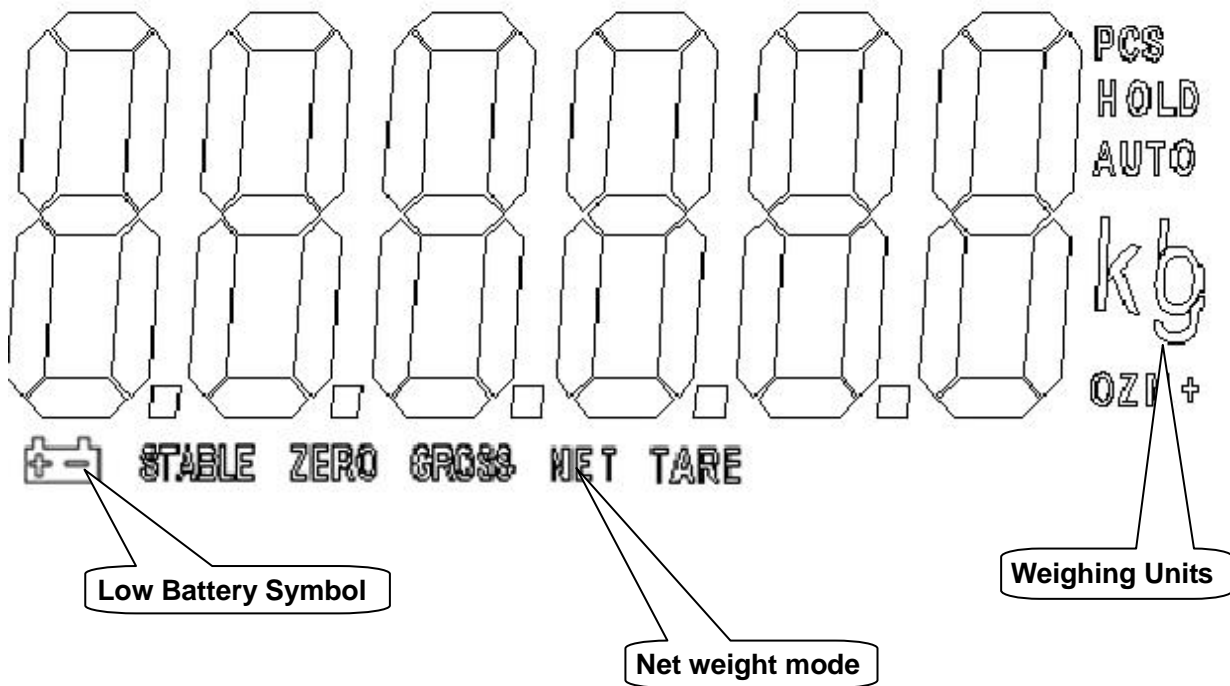

6. OPERATION

6.1 Basic Operation

1. Power On/Off:

Switch on the balance by pressing  key.

The display is switched on and the test is started and if want to switched off, press again the key.



2. Zero

Environmental conditions can lead to the balance exactly zero in spite of the pallet not taking any strain. However, you can set the display of your balance

to zero any time by pressing  key and therefore ensure that the weighing starts at zero.

3. Tare

The weight of any container can be tared by pressing  button so that with subsequent weighing the net weight of the object being weighed is always displayed.

- Load weight on the pallet.
- Press  key. Zero is displayed, and tare is subtracted.
- Remove weight on the pallet. Tared weight is displayed. It can set only one tare value. It will be shown with a minus value.
- Press G/N to change between gross weight and net weight.
- To clear the tare value, remove the load and press  key. Zero is displayed, tare weight is cleared.

4. Weighing Operation

- Pull the control lever in the LOWER position and keep the pallet to the lowest position. Press the  key until the backlight on. After the display self test display will come to "0 lb".
- Place the forks into under pallet and judge by eyes it will be balanced load. Pull the control lever into the ASCENT position; pump the handle to make the fork rise, until you can make sure the pallet leave ground. The stable reading of the indicator is the gross weight of the goods (total weight of the pallet and the goods).













5. Net/Gross change

This function only available after do  operate (NET indicator ON), press  key can shift NET weight display and GROSS weight display (in GROSS display mode, GROSS indicator ON, in NET display mode, NET indicator on).





6.2. Check Weighing

It can set an upper or lower limit when weighing with the limits range. During the limit controls dividing the unit will indicate whether a value upper or lower limits with an alarm sound .

6.2.1. Set Limits

- Press  and  key together, display will show *SET H*
- Press  key to select *SET H* or *SET L*
- Press  key to confirm, display will show *00000* and will blink the last digit.
- Enter the high limit value by using  and  keys to change the active digits and press  key to increment the value.
- Press  key to confirm, display will show *SET L*
- Enter the high limit value by using  and  keys to change the active digits and press  key to increment the value.
- Press  key to confirm.
- To escape from the settings press  key.

6.2.2. Set Check Weighing

- Press  and  key together, display will show *SEt H*
- Press  key to select display *bEEP*.
- Press  key to confirm, display will show *no* or *ot* or *nG*
- **Check mode *no*** : No beep sound in the limits. Function turned off.
- **Check mode *ot*** : When the weight is between the limits. OK will shown and beeper will be sounded.
- **Check mode *nG*** : When the weight is out of the limits, the beeper will be sounded and OK will shown.

Note: Check weighing available only when weight more than 20d

6.3. Accumulation

The scale can be set to accumulate manually by pressing  key. For settings, see the parameter *p 1 Com » mode » pr t and P 2 SUt » ACC*
 Before operation scale should be stable and return to zero, accumulation available only when weight more than 20d

Accumulation Operation

- Place the load on the pallet.
- Press  key, when displayed STABLE indication.
- Display will show *ACC 1* then will be show the total saved value. These displays will be shown only three seconds.
- Remove the weight from the pan.
- When display get zero and stable then place the second weight.
- It can continue until the memory gets fully or 99 items.

6.3.1 Memory Recall

To recall the memory press  key.

Display will show *ACC X* (X: Total number of accumulation) then will be show the total saved value. These displays will be shown only three seconds.

6.3.2. Memory Clear

To clear the memory, press  and  keys together.

Display will show *ACC 0*, all accumulation memory cleared from the memory.

6.3.3. Automatically accumulation.

The scale can be set to accumulate automatically. For settings, see the parameter *P 1 Coñ » ñodE » AUto*

Automatic Accumulation Operation



- Place the load on the pallet.
- When display gets STABLE indication, display will show *ACC 1* then will be show the total saved value. These displays will be shown only three seconds.
- Remove the weight from the pan.
- When display get zero and stable then place the second weight.
- It can continue until the memory gets fully or 99 items.

6.4. Animal Weighing

TPS series can use for vibrate loads weigh. This function can use for animal weighing. For settings, see the parameter *P 4 oñH » Anñ*

Bring the load on the pallet, when the load few seconds get stable, the reading will be locked for few seconds.



It can add or remove loads also update the weighing locked values.

To enter or exit animal weighing mode, press  and  key together. When in animal weighing mode **HOLD** indicator will be displayed.

6.5. Keyboard Lock





It can set lock key board, for settings, see the parameter *P 4 oñH » Loñ*

When the keys are not using with in 10 minutes, the keys will be lock automatically. After entering into the lock function, when we press the keys display will show *t-Loñ*. Then will come to normal display.

If want to unlock and want to use the keys press and hold ,  and  keys three seconds. Display will show *U Loñ* Then will come to normal display

6.6. Set auto power off

It can set auto power off, when scale not in use, scale will turn off after the setting time.



- Hold  key three seconds display will show *SEt oF*
- Press  key to change *SEt oF* and press  key to confirm
- Press  key to change the options.

<i>SEt oF</i>	<i>oF 5</i>	Set to turn off five minutes later
	<i>oF 15</i>	Set to turn off 10 minutes later
	<i>oF oFF</i>	To set auto off function turn off.

- After select the auto off option press  key to confirm and press  key to escape from the settings.

6.7. Set Back Light

It can set back light when scale in use.





- Hold  key three seconds display will show *SEt bL*
- Press  key to confirm

<i>SEt bL</i>	<i>bL AU</i>	To set auto option. When start to use back light will be on and when stop the operation back light also will off.
	<i>bL on</i>	To set always on. After turn on the power, back light also will be on.
	<i>bL oFF</i>	To set back light turn off. No back light in the operations

- After select the back light option press  key to confirm and press  key to escape from the settings.

7. PARAMETERS

To set parameter, turn on the scale.

- Press  key during the self checking.
- Display will show P_n
- Press  ,  and  to enter, display will show P_0 *CHK*









Menu	Sub Menu	Description	
P 0 chk	Net H	Set high limits for check weighing	
	Net L	Set low limits for check weighing	
	PCS H	Set high limits for check PCS	
	PCS L	Set high limits for check PCS	
	beep	No	No beep for check weighing
		Ok	Beep, when check weighing between the limits
ng		Beep, when check weighing out of the limits	
P 1 com	Mode	<p>This option is used to set accumulation and RS-232 communication</p> <p>Options:</p> <p>Cont : data send continues</p> <p>St 1 : Send data one time, when stable.</p> <p>St c : Send data continuously, when stable</p> <p>P rt : To select printer</p> <p>Auto : Auto accumulate and auto print mode. When weight stable and return to zero.</p> <p>Ask : Ask mode, Command R: read data Command T: Tare Command Z: Zero</p> <p>Wireles: Wireless mode (communication through wireless)</p>	
	Baud	To set the baud rate. Options: 600 / 1200 / 2400 / 4800 / 9600	
	Pr	To set the parity Options: 7 e1 / 7 o1 / 8 n1	
P 2 swt	Prt	Only print without accumulation(should clear the accumulation value)	
	ACC	Only accumulation without print	
	Both	Both print and accumulation	
P 3 mod	Count	To check internal counts	
	Deci	To set decimal points	
	Div	To set increment	

TPB series pallet scale technical manual







	Cap	Set Capacity
	Cal	Calibration
	gra	Gravity
P4 oth	Lock	To set keypad lock Options: on / off
	anm	To set animal mode. Options: on / off
P5 Unit	Kg / g / oz. / lb. oz.	To enable/disable each weighing unit options are: (Primary unit is lb.)
P6 ref	Azn 0	Automatic zero tracking Options: 0 .5d , 1 d,, 2 d , 4 d
	0auto	Zero setting range, after switching on the scale to zero. Options: 0% , 2% , 5% ,10% , 20%
	Orange	Manually zero setting range. Options: 2% ,4% ,10% , 20% , 50% , 100%

8. CALIBRATION

To set calibration, turn on the scale.

- Press  key during the self checking.
- Display will show P_n
- Press ,  and , display will show $P_0 CH$
- Press  until display show $P \exists \bar{n}od$
- Press  key to confirm and press  to select CAL
- Press  key to confirm

Calibration CAL

- Press  key to enter calibration, display will show $UnLd$
- Remove all the weight from the pallet.
- When indicator get stable, press  key to confirm.
- Display will be show the last calibration weight. If want to change the calibration weight value, press  and  keys to change the active digits and press  key to increment the value.
- When the calibration value is correct, press  key to confirm.
- Display will show $LoPd$
- Place the calibration weight on the pallet.
- When indicator get stable, press  key to confirm.
- Display will com to normal weighing mode

APPENDIX1: DRAWING OF PUMP ASSEMBLY AND HANDLE

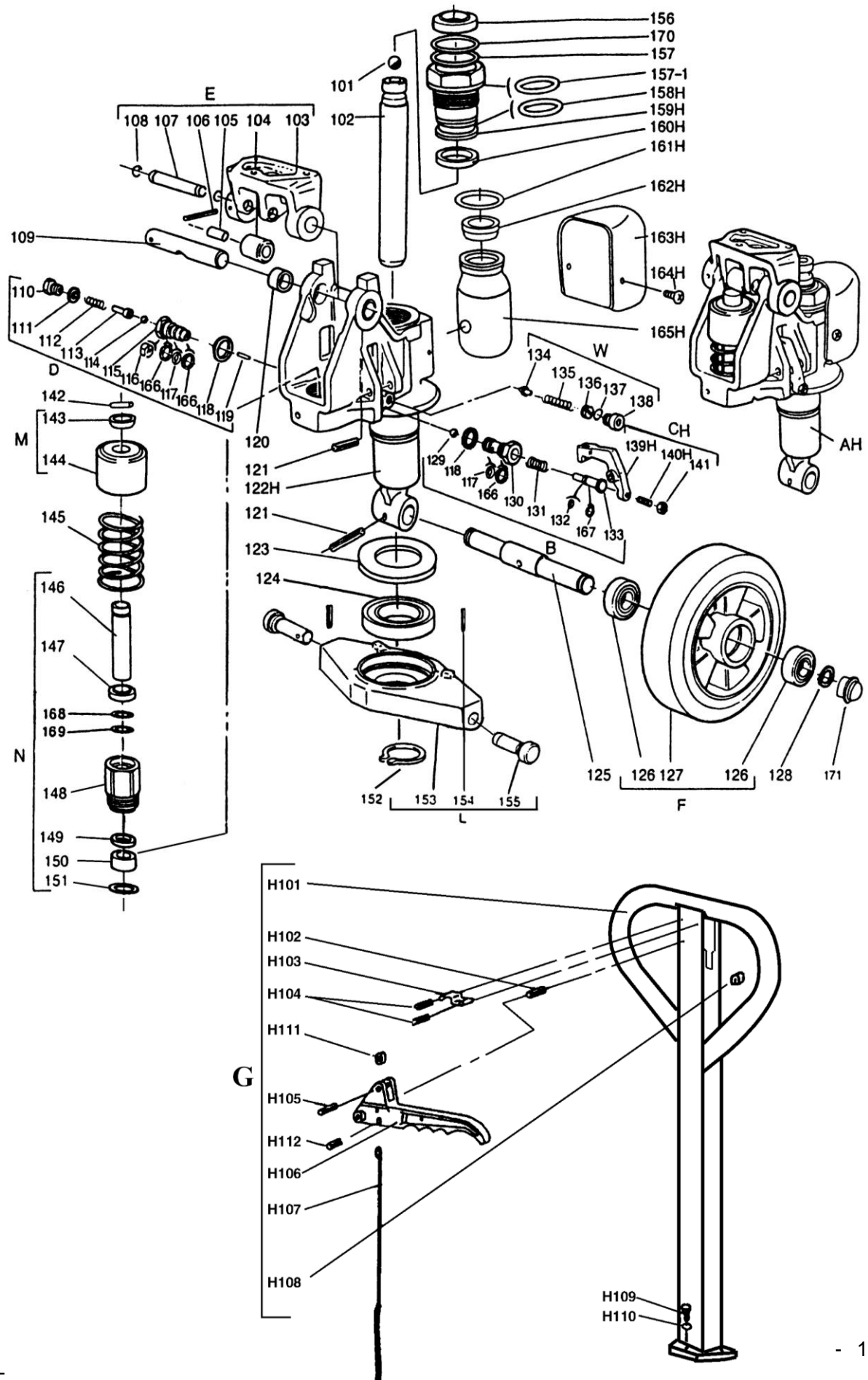

Parts List of Pump Assembly

Part No.	Description	Q'ty	Part No.	Description	Q'ty
101	Steel ball	1	136	Pressure regulating screw O-ring	1
102	Rod	1	137	Screw	1
103	Base	1	138	Crank link	1
104	Steel roller	1	139H	Setting screw	1
105	Bushing	1	140H	Nut	1
106	Pin	1	141	Parallel pin	1
107	Shaft	2	142	Retaining cover	1
108	Retaining ring	1	143	Spring cover	1
109	Axle	1	144	Spring	1
110	Screw	1	145	Pump rod	1
111	Washer	1	146	Dust proof ring	1
112	Spring	1	147	Pump cylinder	1
113	Pressure rod	1	148	Seal ring	1
114	Steel ball	1	149	Nylon bushing	1
115	Pressure valve body	1	150	Red copper washer	1
116	Split ring	1	151	Retaining ring	1
117	O-ring	2	152	Rhombus plate	1
118	Washer	2	153	Pin	1
119	Steel needle	1	154	Dowel pin	2
120	Bushing	2	155	Dust proof ring	2
121	Pin	2	156	O-ring	1
122H	Pump body	1	157	O-ring	1
123	Dust cover	1	157-1	O-ring	1
124	Bearing	1	158H	Cylinder	1
125	Steering wheel axle	1	159H	Seal ring	1
126	Bearing	4	160H	O-ring	1
127A	Steering wheel, Nylon	2	161H	Filler plug	1
127B	Steering wheel, Polyurethane	2	162H	Reservoir cover	1
127C	Steering wheel, Poly/Nylon	2	163H	Screw	1
127D	Steering wheel, Rubber	2	164H	Reservoir	2
128	Retaining ring	2	165H	Retainer	1
129	Steel ball	1	166	Retainer	3
130	Discharge valve body	1	167	Retainer	1
131	Spring	1	168	O-ring	1
132	O-ring	1	169	Retainer	1
133	Discharge valve shaft	1	170	Dust cover	1
134	Valve taper core	1	171	Bearing Cover	2
135	Spring	1			

Parts List of Handle

Part No.	Description	Q'ty	Part No.	Description	Q'ty
H101	Handle	1	H107	Rod and chain	1
H102	Spring pin	1	H108	Rubber cushion	1
H103	Spring leaf	1	H109	Screw	3
H104	Spring pin	2	H110	Spring washer	3
H105	Spring pin	1	H111	Nylon roller	1
H106	Control lever	1	H112	Spring pin	1

APPENDIX2 : DRAWING OF FRAME

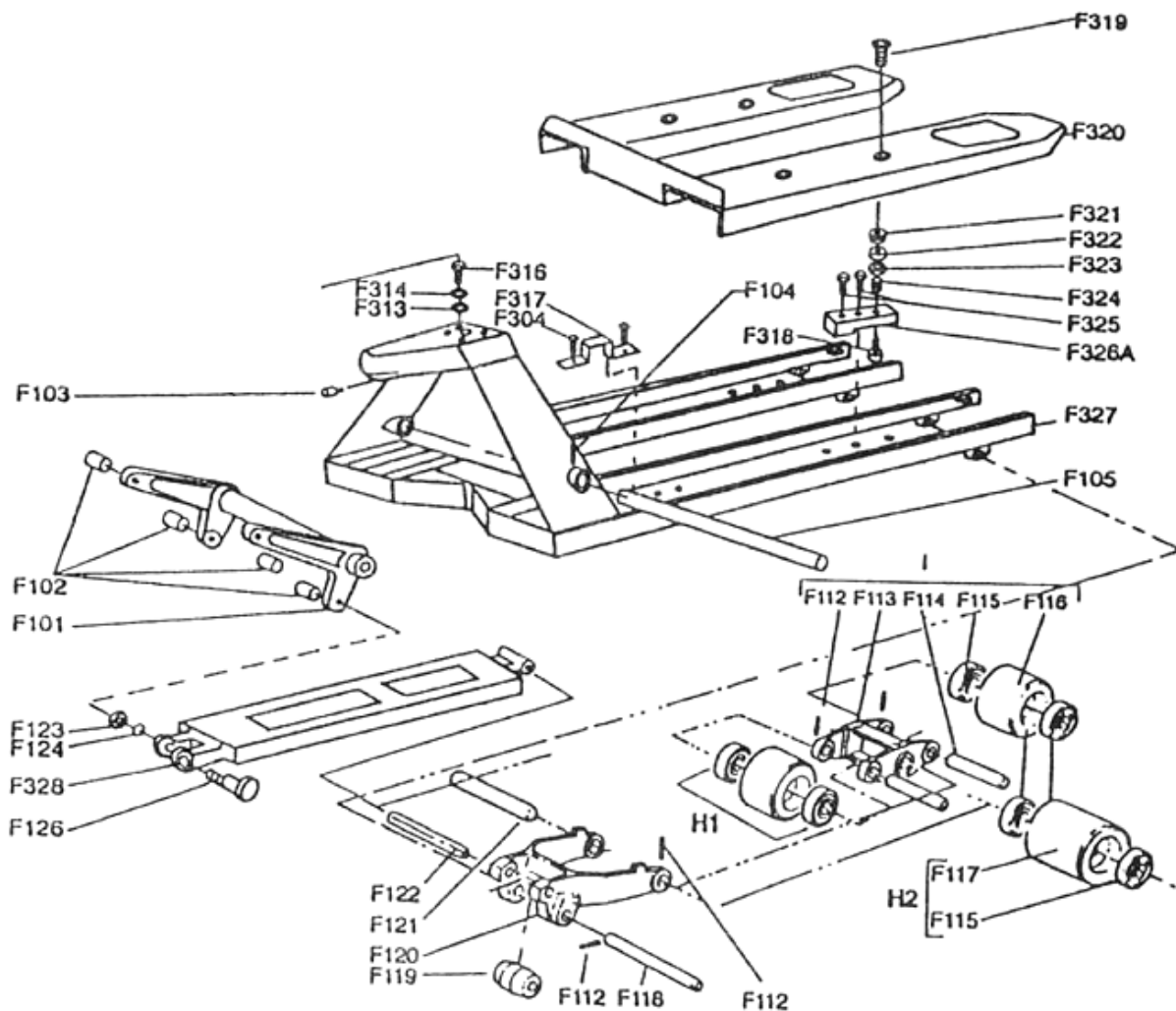

Parts List of Frame

Part No.	Description	Q'ty	Part No.	Description	Q'ty
F304	Screw	4	F102	Bushing	4
F313	Washer	4	F103	Hexagon socket screw	1
F314	Spring washer	3	F104	Spring pin	1
F316	Bolt	4	F105	Torsion tube shaft	1
F317	Wire clip	2	F112	Spring pin	8/4*
F318	Screw	4	F113	H-link	2
F319	Fix screw	4	F114	Load roller axle	4
F320S	Cover plate assembly	1	F115	Bearing	8/4*
F320L	(555mm)	1	F116B	Poly load roller, tandem type	4
F321	Cover plate assembly	4	F117B	Poly load roller, single type	2
F322	(690mm)	4	F118	Axle	2
F323	Convex spherical washer	4	F119	Roller	2
F324	Concave spherical washer	4	F120	Wheel frame	2
F325	Bolt	8	F121	H-link axle	2
F326A	Load cell	4	F122	Pull rod axle	2
F327S	Frame (555mm)	1	F123	Nut	2
F327L	Frame (690mm)	1	F124	Spring washer	2
F328	Pull rod	2	F126	Eccentric pin	2
F101	Torsion tube assembly	1			

Note*: Quantity for tandem roller is 8, for single roller is 4.