

User's Manual | Betriebsanleitung | Mode d'emploi |
Instrucciones de funcionamiento | 操作指示

Sartorius YDK03

Density Determination Kit | Dichtebestimmungsset
Dispositif de détermination de masses volumiques |
Kit para la determinación de la densidad | 密度測定套件

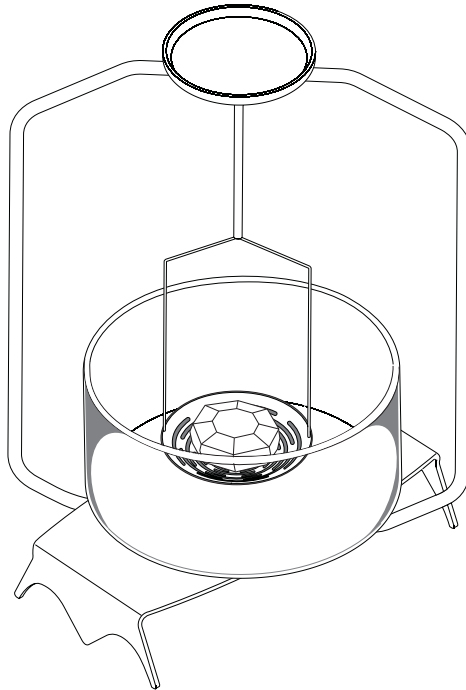

English – page 3

Deutsch – Seite 23

Français – page 43

Español – página 63

中文 – 第 83 页

Contents

Kit Components	5
Getting Started	6
Methods for Determining Specific Gravity/Density.	10
Troubleshooting	11
Determining the Specific Gravity/Density.	14
– of Solids.	14
– of Solids with a Density $<1 \text{ g/cm}^3$	15
– of Liquids.	17
Tables.	18
Density Values of H_2O	18
Density Values of Ethanol	19
Supplement	20

With this Sartorius Density Determination Kit you have acquired a high-quality accessory to your electronic balance.

This accessory kit will ease your daily workload.

Please read this User's Manual carefully before setting up your density determination kit and working with it.

If your balance is equipped with a density determination program, you can have the rho values calculated by the program.

In this case, please follow the operating instructions in "Getting Started."

Then perform density determination as described in the density determination program.

Kit Components

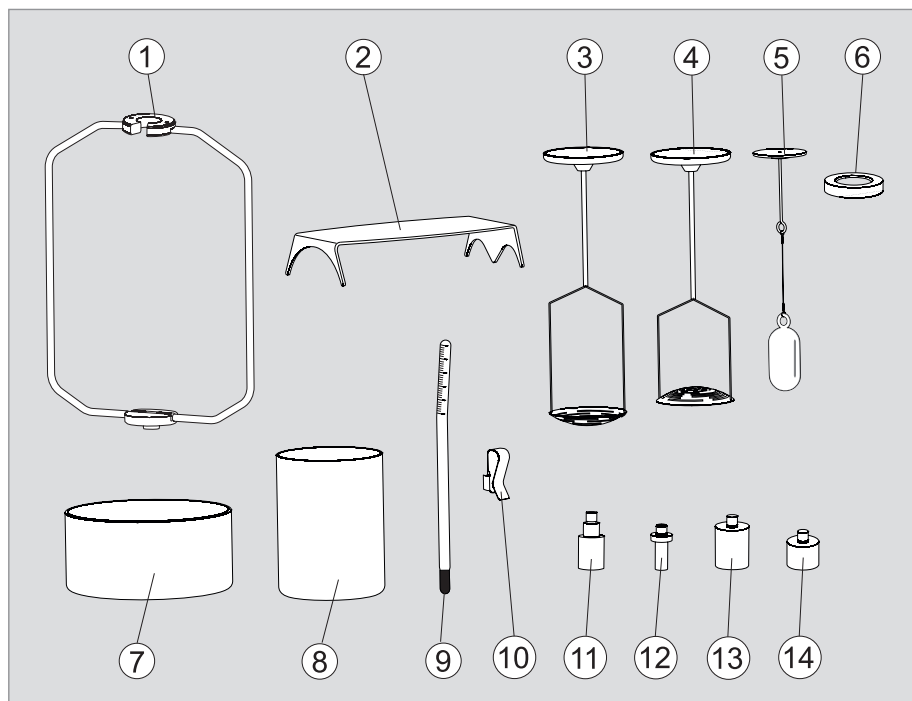

- | | |
|---------------------------------------|---|
| 1 Bar frame | 9 Thermometer |
| 2 Metal plate | 10 Fastening clamp |
| 3 Sample holder (pan hanger assembly) | 11 Adapter "1", for Secura®, Quintix®, Practum® |
| 4 Sieve for immersing samples | 12 Adapter "2", for CPA analytical balances |
| 5 Glass plummet | 13 Adapter "3", for BSA analytical balances |
| 6 Compensating ring | 14 Adapter "4", for Entris analytical balances |
| 7 Beaker (Ø 90 mm) | |
| 8 Beaker (Ø 55 mm) | |

Floor panel (not illustrated)

Getting Started

The YDK03 density determination kit can be used with the following balances:

- Secura[®], Quintix[®], Practum[®] with readability of 1 mg or 0.1 mg
- BSA balances with readability of 0.1 mg
- CPA balances with readability of 0.1 mg
- Entris balances with readability of 0.1 mg

Preparing the Bar Frame

You must mount the adapter before the bar frame can be placed on the balance.

Please use the adapter that is appropriate for the balance you are using.

Approx. dimensions:

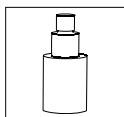

Adapter "1"

- Secura[®], Quintix[®], Practum[®] balances with readability of 1 mg or 0.1 mg

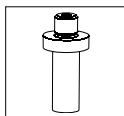

Adapter "2"

- CPA balances with readability of 0.1 mg

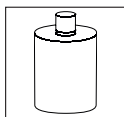

Adapter "3"

- for BSA analytical balances with readability of 0.1 mg

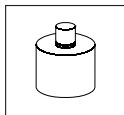

Adapter "4"

- for Entris analytical balances with readability of 0.1 mg

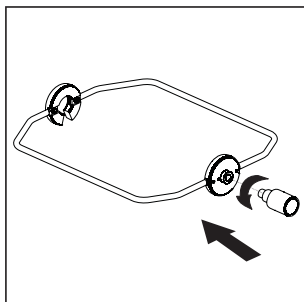

Screw the corresponding adapter into the bar frame base from below:

- For respective adapter, see previous page

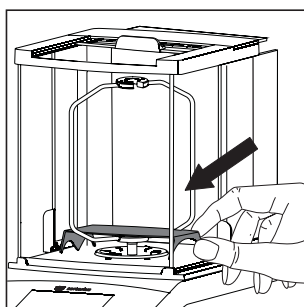

Remove the following parts from the balance:

- Weighing pan
- Pan draft shield (if present)
- Pan support
- Shield disk (if present)

In the case of the Practum® and Quintix® models, replace the white balance floor panel in the draft shield with the stainless steel balance floor panel supplied.

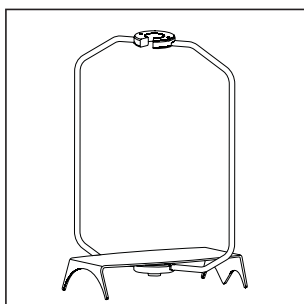

Place the frame in the weighing chamber. The wedge-shaped opening at the top of the frame must face the direction from which the sample holder (sieve/glass plummet) will be placed into the frame.

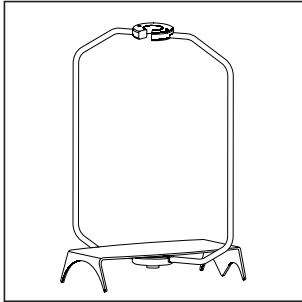

Beaker/Immersion Device

- ▶ Use the metal plate to support the beaker.
Place it on the bar frame base and then set both on the balance.

The choice of the beaker and the immersion device depends on the sample to be determined (see below).

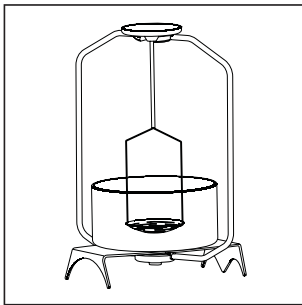

To determine the specific gravity of solids when their density is greater than that of the liquid in which the sample is immersed, use:

- \varnothing 90 mm beaker and sample holder

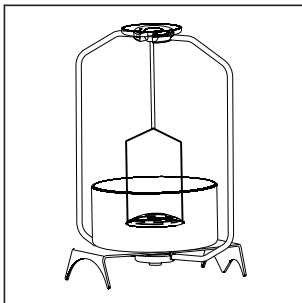

To determine the specific gravity of solids when their density is less than that of the liquid in which the sample is immersed, use:

- 90 mm \varnothing beaker and sieve for immersing the sample

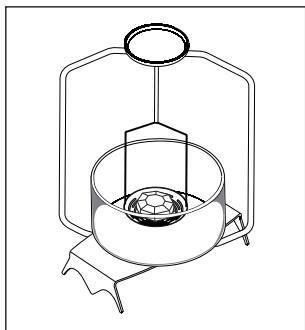

To determine the density of liquids:
- Ø 55 mm beaker and glass plummet

Unpacking the Glass Plummet



Caution: Do not bend the wire on the glass plummet, as the wire might break. Pull the glass plummet out of the packaging by the glass loop to which the wire is attached.

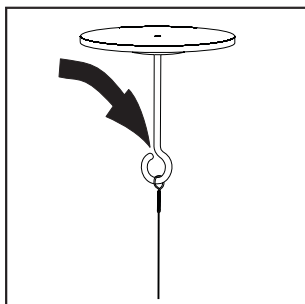

Installing the Glass Plummet

- ▶ Loop the wire on the plummet over the metal hook on the retainer.

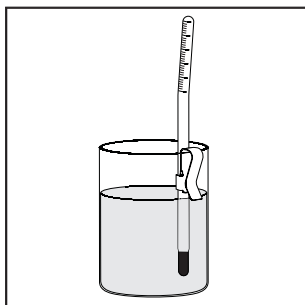

Thermometer

- ▶ If necessary, attach the thermometer to the rim of the beaker using the retainer clip.

Methods for Determining Specific Gravity/Density

The Archimedean principle is applied for determining the specific gravity of a solid with this measuring device:

A solid immersed in a liquid is subjected to the force of buoyancy. The value of this force is the same as that of the weight of the liquid displaced by the volume of the solid.

With a hydrostatic balance which enables you to weigh a solid in air as well as in water, it is possible to:
determine the **specific gravity of a solid** if the density of the liquid causing buoyancy is known:

$$\rho = \frac{W(a) \cdot \rho(fl)}{W(a) - W(fl)}$$

or

determine the **density of a liquid** if the volume of the immersed solid is known:

$$\rho(fl) = \frac{G}{V}$$

where:

- ρ = specific gravity of the solid
- $\rho(fl)$ = density of the liquid
- $W(a)$ = weight of the solid in air
- $W(fl)$ = weight of the solid in liquid
- G = buoyancy of the immersed solid
- V = volume of the solid

Troubleshooting

IMPORTANT!

**When adjusting,
please note:**

Analytical balance:

The sample holder must be removed for adjustment!

Milligram balance:

The sample holder must be installed for adjustment!

The formula on the previous page for determining the specific gravity of solids is sufficient to obtain an accuracy of one to two decimal places.

Depending on the accuracy you require, consider the following error and allowance factors.

- The density of the liquid causing buoyancy depends on its temperature
- Air buoyancy during weighing in air
- The change in the immersion level of the pan hanger assembly when the sample is immersed
- Adhesion of the liquid on the suspension wire of the pan hanger assembly
- Air bubbles on the sample

Some of these errors can be corrected by calculation. To do so, proceed as follows:

- measure the temperature of the reference liquid and correct its density accordingly
and
- define the inner diameter of the container which holds the reference liquid.

Dependence of the Liquid Density on Temperature

The density of the liquid causing buoyancy depends on the temperature. The change in the density per °C change in temperature is in the range of

- 0.02% for distilled water
 - 0.1% for alcohols and hydrocarbons.
- In other words, this can show up in the third decimal place during specific gravity/density determination.

To correct the liquid density for temperature, proceed as follows:

- measure the temperature of the liquid using the thermometer that comes with the kit
- use the table at the back of this manual to find the density of the most commonly used liquids, water and ethanol, at the temperature measured, and use this density for the value ρ (fl).

Air Buoyancy

A volume of 1 cm³ of air has a weight of approximately 1.2 mg, depending on its temperature, humidity and air pressure. When weighed in air, a solid is buoyed by a corresponding force per cm³ of its volume. The error that results if the air buoyancy is not allowed for shows up in the third decimal place and should therefore be corrected.

The following formula allows for air buoyancy:

$$\rho = \frac{W(a) \cdot [\rho(fl) - \rho(a)]}{W(a) - W(fl)} + \rho(a).$$

Where $\rho(a) = 0.0012 \text{ g/cm}^3$ = Density of air under standard conditions (temperature 20°C, pressure 101.325 kPa).

Depth of Immersion

The pan for holding and/or immersing the sample during weighing in liquid is rigidly attached to two wires and is immersed approximately 30 mm below the surface of the liquid. Since the balance is tared before each measurement, the additional buoyancy caused by the immersed part of the measuring device is not allowed for in the specific gravity determination.

When a solid sample is weighed in liquid, a volume of the liquid will be displaced which corresponds to the volume of the solid sample. This causes the attachment wires of the pan hanger assembly to be immersed deeper and generate additional buoyancy which introduces an error in the specific gravity determination.

Use the following formula to correct this error:

$$\rho = \frac{W(a) \cdot [\rho(fl) - \rho(a)]}{\text{corr } [W(a) - W(fl)]} + \rho(a)$$

Since the correction factor is determined exclusively by the geometry of the measuring device setup, be sure to only use the large diameter beaker (90 mm) from the kit when determining the specific gravity of a solid. The "Supplement" to this manual shows how this correction factor is derived.

Adhesion of Liquid to the Wire

When the sample holder (or sieve) is immersed in liquid causing buoyancy, liquid travels up the wire because of adhesion forces and generates an additional weight in the range of a few milligrams.

Since the sample holder (or sieve) is in the liquid causing buoyancy during both weighing in air and weighing in liquid, and the balance is tared at the beginning of each measuring procedure, the effect of the meniscus can be disregarded.

To reduce the surface tension and the friction of liquid on the wire, add three drops of a tenside (Mirasol Antistatic or an ordinary dishwashing detergent) to the distilled water in the beaker.

Because of the liquid travelling up the wire, the weight may slowly change even after the stability symbol “g” appears. Therefore, read off the weight immediately after the “g” is displayed.

Air Bubbles

The measuring error caused by air bubbles adhering to the sample can be estimated in the following manner. An air bubble with a diameter of 0.5 mm causes an additional buoyancy of less than 0.1 mg when a sample is weighed in water. An air bubble diameter of 1 mm causes additional buoyancy of 0.5 mg and an air bubble diameter of 2 mm causes approx. 4.2 mg additional buoyancy. Larger air bubbles must be removed with a fine brush or other utensil.

You can also wet the sample in a separate container before you weigh it.

Determining the Specific Gravity/Density

Determining the Specific Gravity of Solids

Preparation

(Distilled water is used in the description)

- Center the large-diameter beaker (90 mm Ø) on the metal platform
- Fill it so that the distilled water is approximately 5 mm below the rim
- Add three drops of tenside to the distilled water
- Attach the thermometer to the rim of the beaker using the retainer clip
- Clean the sample holder with a solvent (especially the wires that will be immersed) and hang it from the frame

Measuring Procedure

Determining the Weight of a Sample in Air

- Tare the balance
- Place the sample on the upper pan on the frame and weigh
- Record the weight $W(a)$

Determining the Buoyancy

$$G = W(a) - W(fl)$$

- Tare the balance with the sample on the upper pan on the frame
- Place the sample in the sample holder¹⁾
- Record the absolute readout of the buoyancy "G," which is displayed with a negative sign

Calculating the Specific Gravity

- Read off the temperature of the liquid
- Using the tables at the back of this manual, find the density $\rho(fl)$ which corresponds to the temperature measured for the liquid you are using
- Calculate specific gravity using the following formula:

$$\rho = \frac{W(a) \cdot [\rho(fl) - 0.0012 \text{ g/cm}^3]}{\text{corr } G} + 0.0012 \text{ g/cm}^3$$

$W(a)$ and G in g; $\rho(fl)$ in g/cm^3

$$G = W(a) - W(fl)$$

¹⁾ If you remove the pan hanger assembly from the measuring device to do this, make sure that no additional air bubbles are on it when you re-immerses it; it is better to place the sample directly on the pan using forceps or a similar utensil.

Determining the Specific Gravity of Solids with a Density Less Than 1 g/cm³

There are two different methods for determining the specific gravity of solids with a density less than 1 g/cm.

Method 1:

For this method, distilled water is still used as the liquid causing buoyancy, but the pan hanger assembly is replaced by the sieve for immersing samples.

To determine the sample's buoyancy, float it on the surface of the water and then immerse it using the sieve. It is also possible to use forceps or a similar tool to place the sample directly under the sieve (without removing the sieve from the frame).

If the buoyancy of the substance to be measured is so high that the weight of the sieve is not enough to immerse the sample, increase the weight of the sieve by adding an additional weight to the upper pan on the frame.

Method 2:

(for this method, use the sample holder) Here, use a liquid for causing buoyancy with lower density than that of the solid for which the specific gravity is to be determined. We have had good results with ethanol (up to a density of approx. 0.8 g/cm³).

The density ρ (fl) of ethanol (with reference to its temperature) can be found in the table in the supplement.

The negative effect of the liquid's surface tension on the results is less noticeable when ethanol is used than when distilled water is employed. Therefore, it is not necessary to add tensides.

When working with ethanol, you must observe the valid safety precautions.

Use Method 2 if the density of the solid varies only slightly from that of distilled water. Since the sample is suspended in water, measuring errors may occur if the first method is used.

It also makes sense to use the second method when determining the specific gravity of a granulated substance, since it would be difficult to get the entire sample under the sieve as required when performing the first method. Do not use ethanol if the sample could be attacked or dissolved by it.

Preparation (for Method 1 only)

(Distilled water is used in the description.)

- Center the large-diameter beaker (90 mm Ø) on the metal platform
- Fill it so that the distilled water is approximately 5 mm below the rim
- Add three drops of tenside to the distilled water
- Attach the thermometer to the rim of the beaker using the retainer clip
- Clean the sieve with a solvent (especially the wires that will be immersed) and hang it from the frame

Measuring Procedure (for Method 1 only)

Determining the Weight of the Sample in Air

- Tare the balance
- Place the sample on the frame weighing pan and weigh
- Record the weight $W(a)$

Determining the Buoyancy

$$G = W(a) - W(fl)$$

- Tare the balance again (with the sample on the frame weighing pan)
- Place the sample under the sieve or immerse it below the surface of the liquid using the sieve¹⁾
- Record the buoyancy "G," which is displayed with a negative sign

Calculating the Specific Gravity

- Read off the temperature of the liquid
- Using the table at the back of this manual, find the density $\rho(fl)$ which corresponds to the temperature measured for distilled water
- Calculate the specific gravity using the following formula:

$$\rho = \frac{W(a) \cdot \rho(fl)}{\text{corr } G} + 0.0012 \text{ g/cm}^3$$

$W(a)$ and G in g; $\rho(fl)$ in g/cm^3

$$G = W(a) - W(fl)$$

¹⁾ If you remove the pan hanger assembly from the measuring device to do this, make sure that no additional air bubbles are on it when you re-immerses it in the liquid; it is better to place the sample directly under the pan using forceps or a similar utensil.

Determining the Density of Liquids

Preparation

- Center the small-diameter beaker (55 mm Ø) on the metal platform
- Attach the thermometer to the rim of the beaker using the retainer clip

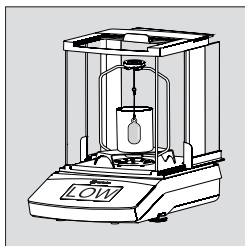

- When „LOW“ is displayed, add the compensating ring.

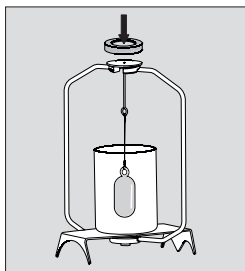

Measuring Procedure

- Suspend the disk with the glass plummet (hanging on one wire) from the frame
- Tare the balance
- Fill the beaker with the liquid to be tested so that the liquid is 10 mm above the glass plummet

Determining the Buoyancy

$$G = W(a) - W(fl)$$

The negative weight displayed by the balance corresponds to the buoyancy acting on the glass plummet in the liquid.

- Record the buoyancy displayed with a negative sign
- Read off the temperature and record it

Calculating the Density

- Calculate the density using the following formula:

$$\rho(fl) = \frac{G}{V}$$

G in g; V in cm³

The glass plummet included in the specific gravity/density determination kit has a volume of 10 cm³.

It is easy to obtain the current density of the liquid (in g/cm³); you will not need a calculator. Mentally shift the decimal point in the balance display one place to the left.

Tables

Density of H₂O at Temperature T (in °C)

T/°C	0.0	0.1	0.2	0.3	0.4	0.5	0.6	0.7	0.8	0.9
10.	0.99973	0.99972	0.99971	0.99970	0.99969	0.99968	0.99967	0.99966	0.99965	0.99964
11.	0.99963	0.99962	0.99961	0.99960	0.99959	0.99958	0.99957	0.99956	0.99955	0.99954
12.	0.99953	0.99951	0.99950	0.99949	0.99948	0.99947	0.99946	0.99944	0.99943	0.99942
13.	0.99941	0.99939	0.99938	0.99937	0.99935	0.99934	0.99933	0.99931	0.99930	0.99929
14.	0.99927	0.99926	0.99924	0.99923	0.99922	0.99920	0.99919	0.99917	0.99916	0.99914
15.	0.99913	0.99911	0.99910	0.99908	0.99907	0.99905	0.99904	0.99902	0.99900	0.99899
16.	0.99897	0.99896	0.99894	0.99892	0.99891	0.99889	0.99887	0.99885	0.99884	0.99882
17.	0.99880	0.99879	0.99877	0.99875	0.99873	0.99871	0.99870	0.99868	0.99866	0.99864
18.	0.99862	0.99860	0.99859	0.99857	0.99855	0.99853	0.99851	0.99849	0.99847	0.99845
19.	0.99843	0.99841	0.99839	0.99837	0.99835	0.99833	0.99831	0.99829	0.99827	0.99825
20.	0.99823	0.99821	0.99819	0.99817	0.99815	0.99813	0.99811	0.99808	0.99806	0.99804
21.	0.99802	0.99800	0.99798	0.99795	0.99793	0.99791	0.99789	0.99786	0.99784	0.99782
22.	0.99780	0.99777	0.99775	0.99773	0.99771	0.99768	0.99766	0.99764	0.99761	0.99759
23.	0.99756	0.99754	0.99752	0.99749	0.99747	0.99744	0.99742	0.99740	0.99737	0.99735
24.	0.99732	0.99730	0.99727	0.99725	0.99722	0.99720	0.99717	0.99715	0.99712	0.99710
25.	0.99707	0.99704	0.99702	0.99699	0.99697	0.99694	0.99691	0.99689	0.99686	0.99684
26.	0.99681	0.99678	0.99676	0.99673	0.99670	0.99668	0.99665	0.99662	0.99659	0.99657
27.	0.99654	0.99651	0.99648	0.99646	0.99643	0.99640	0.99637	0.99634	0.99632	0.99629
28.	0.99626	0.99623	0.99620	0.99617	0.99614	0.99612	0.99609	0.99606	0.99603	0.99600
29.	0.99597	0.99594	0.99591	0.99588	0.99585	0.99582	0.99579	0.99576	0.99573	0.99570
30.	0.99567	0.99564	0.99561	0.99558	0.99555	0.99552	0.99549	0.99546	0.99543	0.99540

Density of Ethanol at Temperature T (in °C)

T/°C	0.0	0.1	0.2	0.3	0.4	0.5	0.6	0.7	0.8	0.9
10.	0.79784	0.79775	0.79767	0.79758	0.79750	0.79741	0.79733	0.79725	0.79716	0.79708
11.	0.79699	0.79691	0.79682	0.79674	0.79665	0.79657	0.79648	0.79640	0.79631	0.79623
12.	0.79614	0.79606	0.79598	0.79589	0.79581	0.79572	0.79564	0.79555	0.79547	0.79538
13.	0.79530	0.79521	0.79513	0.79504	0.79496	0.79487	0.79479	0.79470	0.79462	0.79453
14.	0.79445	0.79436	0.79428	0.79419	0.79411	0.79402	0.79394	0.79385	0.79377	0.79368
15.	0.79360	0.79352	0.79343	0.79335	0.79326	0.79318	0.79309	0.79301	0.79292	0.79284
16.	0.79275	0.79267	0.79258	0.79250	0.79241	0.79232	0.79224	0.79215	0.79207	0.79198
17.	0.79190	0.79181	0.79173	0.79164	0.79156	0.79147	0.79139	0.79130	0.79122	0.79113
18.	0.79105	0.79096	0.79088	0.79079	0.79071	0.79062	0.79054	0.79045	0.79037	0.79028
19.	0.79020	0.79011	0.79002	0.78994	0.78985	0.78977	0.78968	0.78960	0.78951	0.78943
20.	0.78934	0.78926	0.78917	0.78909	0.78900	0.78892	0.78883	0.78874	0.78866	0.78857
21.	0.78849	0.78840	0.78832	0.78823	0.78815	0.78806	0.78797	0.78789	0.78780	0.78772
22.	0.78763	0.78755	0.78746	0.78738	0.78729	0.78720	0.78712	0.78703	0.78695	0.78686
23.	0.78678	0.78669	0.78660	0.78652	0.78643	0.78635	0.78626	0.78618	0.78609	0.78600
24.	0.78592	0.78583	0.78575	0.78566	0.78558	0.78549	0.78540	0.78532	0.78523	0.78515
25.	0.78506	0.78497	0.78489	0.78480	0.78472	0.78463	0.78454	0.78446	0.78437	0.78429
26.	0.78420	0.78411	0.78403	0.78394	0.78386	0.78377	0.78368	0.78360	0.78351	0.78343
27.	0.78334	0.78325	0.78317	0.78308	0.78299	0.78291	0.78282	0.78274	0.78265	0.78256
28.	0.78248	0.78239	0.78230	0.78222	0.78213	0.78205	0.78196	0.78187	0.78179	0.78170
29.	0.78161	0.78153	0.78144	0.78136	0.78127	0.78118	0.78110	0.78101	0.78092	0.78084
30.	0.78075	0.78066	0.78058	0.78049	0.78040	0.78032	0.78023	0.78014	0.78006	0.77997

Supplement

This supplement should help you to better understand how the formulas and allowance factors used here have been derived.

Fundamental Principles

$$\text{Density} = \frac{\text{Mass (g)}}{\text{Volume (cm}^3\text{)}}$$

The Archimedean Principle:

A solid immersed in a liquid is exposed to the force of buoyancy (G). This value is the same as that of the weight of the liquid displaced by the volume of the solid. The volume of an immersed solid V (s) equals the volume of the displaced liquid V (fl).

The following are determined:

1. The weight of the sample in air: W (a)
2. The buoyancy of the solid in liquid: G

The specific gravity of a solid is:

$$\rho = \frac{\text{sample mass}}{\text{sample volume}} = \frac{W (a)}{V (s)} = \frac{W (a)}{V (fl)}$$

If the density ρ (fl) of the displaced liquid is known, then

$$V (fl) = \frac{\text{Mass (fl)}}{\rho (fl)} = \frac{G}{\rho (fl)}$$

Therefore:

$$\rho = \frac{W (a) \cdot \rho (fl)}{G}$$

Calculation

The **specific gravity of a solid** is calculated from the ratio

$$\rho : W (a) = \rho (fl) : W (a) - W (fl),$$

where:

$$\rho = \frac{W (a) \cdot \rho (fl)}{W (a) - W (fl)}$$

$$W (a) - W (fl) = G =$$

buoyancy of the sample

The **density of a liquid** is determined from the buoyancy of the plummet, which has a defined volume

$$V (fl) = \frac{G}{\rho}$$

where:

ρ = specific gravity of a solid

ρ (fl) = density of the liquid

W (a) = weight of the solid in air

W (fl) = weight of the solid in liquid

G = buoyancy of the plummet

V = volume of the solid

Corrections When Used with Entris Models

You must allow for the following when determining the specific gravity of solids:

- **the air buoyancy that affects the sample weighed in air**

where $\rho (a) = 0.0012 \text{ g/cm}^3 =$ density of air under standard conditions (temperature 20°C , pressure 101.325 kPa); which results in the following:

$$\rho = \frac{W (a) \cdot [\rho (fl) - \rho (a)]}{W (a) - W (fl)} + \rho (a)$$

- **the immersion of the wires of the sample holder or sieve**

When using this specific gravity determination kit, you must multiply the buoyancy $G = [W (a) - W (fl)]$ by the correction factor (corr).

Advanced formula:

$$\rho = \frac{W (a) \cdot [\rho (fl) - \rho (a)]}{[W (a) - W (fl)] \cdot \text{Corr}} + \rho (a)$$

This factor allows for the buoyancy of the wires which are submerged deeper when the sample is in the sample holder.

How this allowance factor is derived:

The buoyancy caused by the submerged wires depends on the height “h” by which the liquid rises when the sample is immersed.

Here, the sample volume $V (pr)$ corresponds to the liquid volume $V (fl)$. The sample volume is determined by measuring the buoyancy. Hence, it is:

$$V (pr) = V (fl)$$

or

$$\frac{W (a) - W (fl)}{\rho (fl)} = \frac{\pi \cdot h \cdot D^2}{4}$$

$$\text{Therefore, } h = \frac{4 \cdot [W (a) - W (fl)]}{\rho (fl) \cdot \pi \cdot D^2}$$

The buoyancy “A” caused by the immersed wires is:

$$A = 2 \cdot \frac{\pi \cdot d^2}{4} \cdot h \cdot \rho (fl)$$

When “h” is used:

$$\rho = \frac{2 \cdot \pi \cdot d^2 \cdot 4 \cdot [W (a) - W (fl)] \cdot \rho (fl)}{4 \cdot \rho (fl) \cdot \pi \cdot D^2}$$

$$A = 2 \cdot \frac{d^2}{D^2} \cdot [W (a) - W (fl)]$$

To allow for the buoyancy of the wires, subtract the buoyancy “A” caused by the immersed wires from the buoyancy determined for the sample:
 $G = W(a) - W(fl)$. The corrected buoyancy “A (corr)” to use in this calculation is then: $G - “A.”$

$$A(\text{corr}) = [W(a) - W(fl)] - 2 \cdot \frac{d^2}{D^2} \cdot [W(a) - W(fl)]$$

$$A(\text{corr}) = \left[1 - 2 \cdot \frac{d^2}{D^2} \right] \cdot [W(a) - W(fl)]$$

The specific gravity determination kit uses the large-volume beaker (90 mm \varnothing) and an immersing device with 2 wires (0.7 mm diameter) for the determination of the specific gravity of solids.

When the values $d = 0.7$ mm and $D = 90$ mm are plugged into the equation, the correction factor is:

$$1 - 2 \cdot \frac{0.7^2}{90^2} = \mathbf{0.99988}$$

When using devices with other dimensions, the correction factor must be recalculated.