

# DL-100

## Economic Bench Scale

- Battery Operated
- Easy to Read LCD Display
- Auto Power Off



ISO 9001 certified

**CAS**  
S · C · A · L · E

# DL-100 Economy Bench Scale

## FEATURES

- Battery Operated.
- Standard AC Adapter.
- On/Off, Zero, Tare, Counting, and Hi/Lo Functions.
- Easy to Read LCD Displays.
- Auto Span Adjustment.
- Auto Zero Tracking.
- kg / lb Switchable.

## SPECIFICATIONS

Model	DL-100
Weighing Capacity	200 lb x 0.1 lbs (100 kg x 50 g)
Measurement Type	Load Cell
Display Type	LCD (6 Digit)
Power Source	DC 9V (1.5V x 6EA) / AC Adapter
Power Consumption	1W (Adapter)
Operating Temperature	- 10°C ~ +40°C (14°F ~ 104°F)
Weighing Pan (inch / mm)	13.6 (W) x 18.3 (D) / 345 (W) x 465 (D)
Dimensions (inch / mm)	16.5 (W) x 25 (D) x 28.7 (H) / 420 (W) x 635 (D) x 730 (H)
Product Weight	35.3 lb / 16 kg

## DIMENSIONS

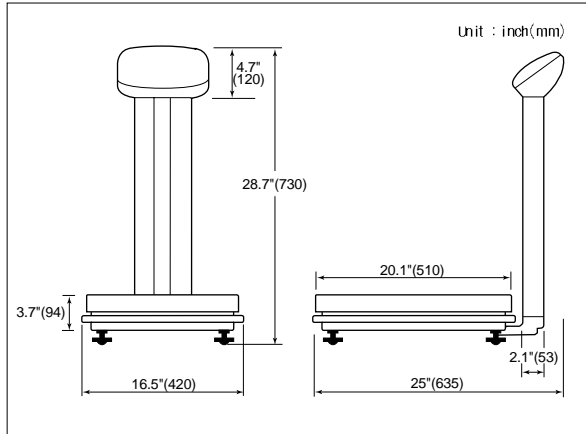

## DISPLAY & KEY BOARD



## KEY FUNCTION

- Mode Functions
  - kg / lb Conversion Mode
  - HI / LO Mode
  - Counting Mode



## CAS USA Corporation

NJ OFFICE  
 99 Murray Hill Parkway  
 East Rutherford, NJ 07073  
 Tel: (201) 933-9002  
 Fax: (201) 933-9025

<http://www.cas-usa.com>

CA OFFICE  
 733 S. State College Blvd #98  
 Fullerton, CA 92831  
 Tel: (714) 870-1286  
 Fax: (714) 870-1167