

TBM4

BEAM LOAD CELL

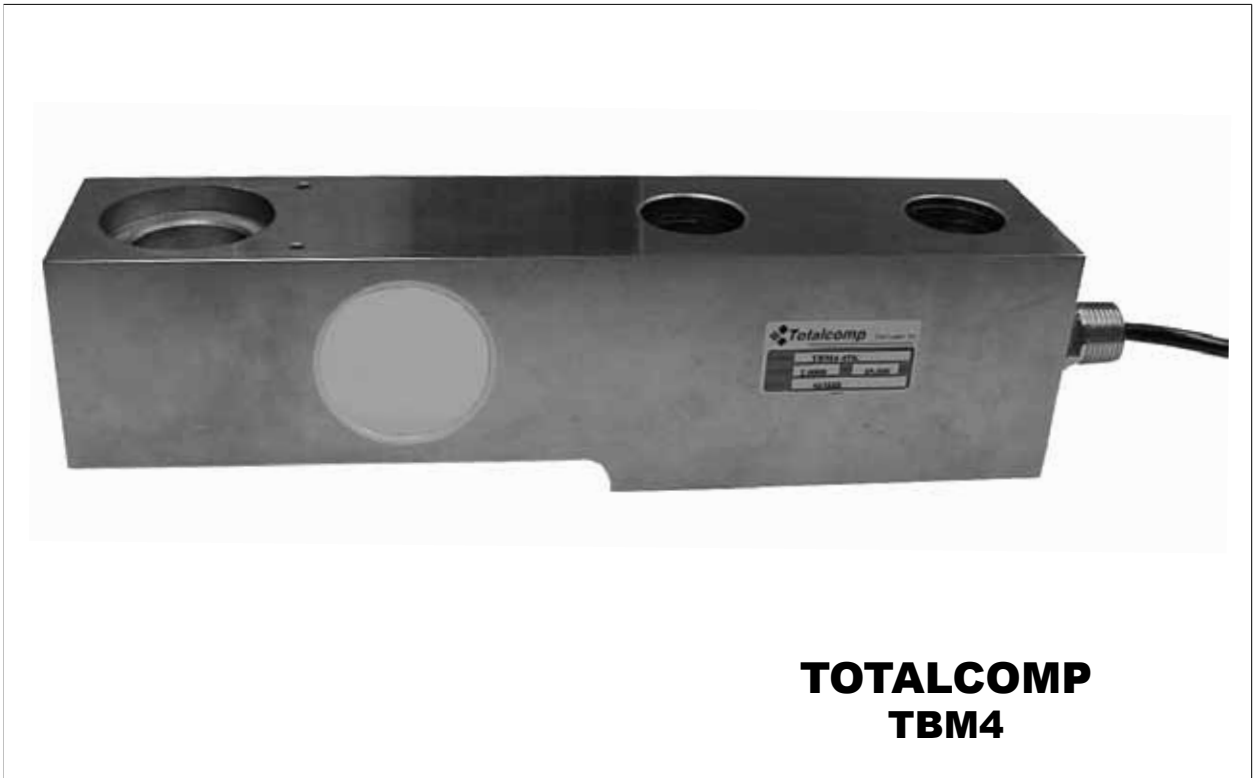

Superior Quality, Stainless Steel Beam Load Cells from Totalcomp

✓ *Stainless Steel Housing.*

✓ *Reliable - Durable - Precise.*

✓ *Environmentally Sealed.*

✓ *30 ft. four conductor cable.*



Totalcomp[®] Scales & Components

99 Reagent Lane • Fair Lawn, New Jersey 07410

Fax: 201-797-2287 • Toll Free Fax: 888-797-2288 • Phone: 201-797-2718 • Toll Free Phone: 800-631-0347

Email: sales@totalcomp.com • Website: www.totalcomp.com

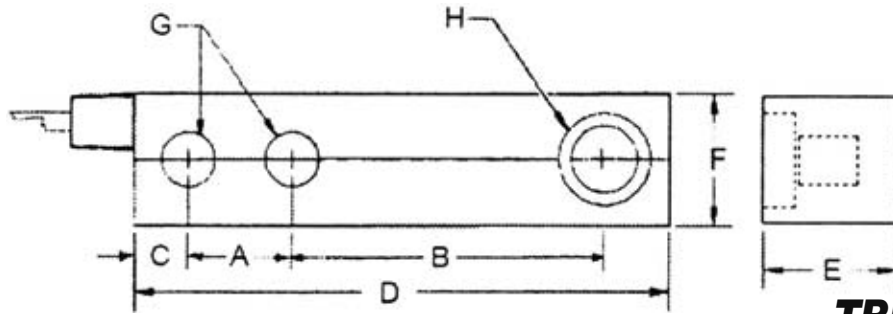

TBM4

TBM4 STAINLESS STEEL BEAM LOAD CELL **Interchangeable with Toledo®/ Masstron ML4447 Load Cells**

The *Totalcomp* TBM4 series load cells are top quality, environmentally sealed units. The environmentally sealed stainless steel housing provides protection when used in areas where foreign particles and/or corrosive substances are present.

Part Number	Toledo®	Capacity	Weight	A	B	C	D	E	F	G	H
TBM4-35K	ML4437	35,000 lb	26 lb	3.50	6.25	125	12.50	2.75	2.75	1.31	1.50
TBM4-45	ML4447/49	45,000 lb	28 lb	3.50	6.25	125	12.50	2.75	2.75	1.31	1.50
TBM4-45*	13329000B	45,000 lb	28 lb	3.50	6.25	125	12.50	2.75	2.75	1.31	1.50
*2,000 ohm bridge											
Old style w/o step (w/o pistol grip)											
TBM4-45K-OS	ML4447/49	45,000 lb	28 lb	3.50	6.25	125	12.50	2.75	2.75	1.31	1.50
TBM4-45K-OS*	13329000B	45,000 lb	28 lb	3.50	6.25	125	12.50	2.75	2.75	1.31	1.50
*2,000 ohm bridge											

Performance

Full Scale Output
2.00 mV/V

Combined Error
±0.05% FS

Nonlinearity
±0.05% FS

Hysteresis
±0.05%

Creep
±0.03% FS in 20 min

Non-Repeatability
±0.05% FS

Zero Balance
±1% FS

Overload Safe
100% FS

Overload Ultimate
150% FS

Electrical
Bridge Resistance
 Input 350 ohms
 Output 350 ohms

Excitation Voltage
10VDC (15VDC Max)

Insulation Resistance
10KM ohms @ 50VDC

Temperature

Compensated Range
-10°C to +40°C

Temperature Operating Range
-10°C to +40°C

Effect on Zero Balance
0.003% FS/deg F

Effect on FS Output
0.002% FS/deg F

Mechanical

Material
Stainless Steel

Finish
Polished

Sealing
NEMA 4

Wiring

Cable Length & Type
30 foot, 4 conductor

Cable Color Code
 + Excitation.....Green
 - Excitation.....Black
 + Output.....White
 - Output.....Red
 Shield.....Yellow

TOTALCOMP LIMITED WARRANTY

Totalcomp warrants this product to be free of defects in materials and/or workmanship and suitable for the purpose(s) intended as outlined on this sheet. This warranty is effective and shall cover the purchaser for one year from the date of shipment from our plant. If this product is found to be defective by our inspection in accordance with the above listed criteria, we will replace or repair it at our expense. For warranty service, please obtain a return authorization number from us and return the item, shipping prepaid, with a written description of the problem. We will respond promptly with the results of our evaluation.



Totalcomp®

Scales & Components

99 Reagent Lane

Fair Lawn, NJ 07410

Fax (201) 797-2287

Toll Free Fax (888) 797-2288

Phone (201) 797-2718

Toll Free Phone (800) 631-0347

Email sales@totalcomp.com

Website www.totalcomp.com