

AD-4401A

Weighing Indicator



INSTRUCTION MANUAL



1WMPD4003050C

WARNING DEFINITIONS

The warnings described in this manual have the following meanings:

 WARNING	A potentially hazardous situation which, if not avoided, could result in death or serious injury.
 CAUTION	A potentially hazardous situation which, if not avoided, may result in minor or moderate injury or damage to the instrument.

© 2017 A&D Company, Limited. All rights reserved.

No part of this publication may be reproduced, transmitted, transcribed, or translated into any language in any form by any means without the written permission of A&D Company, Limited.

The contents of this manual and the specifications of the instrument covered by this manual are subject to change for improvement without notice.

CONTENTS

CONTENTS.....	1
1. SAFETY PRECAUTIONS.....	4
2. PART NAMES	5
2.1. Front Panel.....	5
2.2. Rear Panel.....	6
2.3. Accessories.....	6
3. INSTALLATION TO CONTROL PANEL.....	7
4. CONNECTION TO POWER SUPPLY.....	8
4.1. AC Power Input Terminal Assignment.....	8
4.2. Connection Diagram	8
5. CONNECTION TO LOAD CELL.....	9
5.1. Load Cell Input Terminal Assignment.....	9
5.2. Connection Diagram	10
6. CALIBRATION.....	11
6.1. Calibration Setting.....	11
6.2. Calibration Using Calibration Weights	12
7. BASIC WEIGHING FUNCTIONS	14
8. BATCH WEIGHING FUNCTIONS	17
8.1. Normal Batching.....	17
8.2. Loss-in-weight Batching	20
8.3. Sequential Weighing Functions.....	23
8.4. Simple Comparison Normal Batching.....	25
8.5. Simple Comparison Loss-in-weight Batching	26
8.6. Simple Comparison Functions.....	26
9. CHECK WEIGHING FUNCTIONS.....	27
9.1. Check Weighing 1	27
9.2. Check Weighing 2	28
9.3. Check Weighing 3	29
9.4. Check Weighing 4	30
9.5. Check Weighing Functions.....	30

10. CONTROL I/O	31
10.1. Pin Assignment	31
10.2. Connection Diagram.....	32
10.3. Control Input Method.....	33
11. SETPOINT INPUT	34
11.1. Pin Assignment	34
11.2. Connection Diagram.....	37
12. STANDARD SERIAL OUTPUT	38
12.1. Pin Assignment	38
12.2. Communication Specifications	38
12.3. Output Data.....	39
12.4. Communication Type	39
12.5. Output Data Format.....	40
13. OPTION-01 BCD OUTPUT	42
13.1. Pin Assignment	42
13.2. Connection Diagram.....	43
13.3. Data Output Timing	44
13.4. Data Output Logic and Strobe Output Logic.....	44
14. OPTION-03 RS-422/485.....	45
14.1. Terminal Assignment.....	45
14.2. Connection Diagram.....	45
14.3. Communication Specifications	47
14.4. Output Data.....	47
14.5. Communication Type	47
14.6. Format When Communication Type (rS F-02) is 1, 2, 3 or 7.....	48
14.7. Format When Communication Type (rS F-02) is 5 or 6	50
14.8. Format When Communication Type (rS F-02) is 8	51
14.9. Format When Communication Type (rS F-02) is 4	52
14.10. Modbus-RTU When Communication Type (rS F-02) is 9	56
15. OPTION-04 RS-232C	60
15.1. Pin Assignment	60
15.2. Connection Diagram.....	61
15.3. Communication Specifications	61
15.4. Output Data, Communication Type	61

16. OPTION-07 ANALOG 4-20 MA OUTPUT.....	62
16.1. Terminal Assignment.....	62
16.2. Connection Diagram.....	62
16.3. Output Specifications.....	63
16.4. Output Functions.....	63
17. SETPOINT SETTING.....	64
17.1. Setting Using Key Switches.....	64
17.2. Setpoint Values List.....	66
18. OPERATION CHECKING.....	67
18.1. Checking Key Switches.....	68
18.2. Checking Control Input/Output.....	68
18.3. Checking Standard Serial Output.....	68
18.4. Checking BCD Output.....	69
18.5. Checking RS-422/485, RS-232C.....	69
18.6. Checking Setpoint Input.....	69
18.7. Checking Analog 4-20 mA Output.....	70
18.8. Checking Load Cell Input.....	70
18.9. Checking Software Version.....	70
18.10. Checking the Load Cell Connection with a Digital Multimeter.....	71
18.11. Check List.....	72
19. INITIALIZATION.....	73
19.1. Parameter Initialization.....	73
19.2. General Function Initialization.....	73
19.3. All Data Initialization.....	74
20. FUNCTION LIST.....	75
20.1. Calibration Function Setting.....	75
20.2. General Function Setting.....	77
20.3. Calibration Functions.....	79
20.4. Basic Functions.....	81
20.5. Weighing Sequence Functions.....	83
20.6. Control Input Functions.....	85
20.7. Control Output Functions.....	86
20.8. Standard Serial Output Functions.....	87
20.9. BCD Output Functions.....	87
20.10. RS-422/485, RS-232C Functions.....	88
20.11. Setpoint Input Functions.....	89
20.12. Analog 4-20 mA Output Functions.....	89
21. SPECIFICATIONS.....	90

1. SAFETY PRECAUTIONS

For safe and correct usage, read the following precautions carefully before using the indicator.

Precautions on designing

WARNING

- Provide an external safety circuit to the indicator so that the safety of the whole system can be secured even if errors occur in the external power supply or in the indicator.

Precautions on installation

WARNING

- Do not use the indicator in the following environment:
 - where the temperature and the humidity exceed the specifications
 - where corrosive gases or flammable gases exist
 - where the indicator gets wet with oil, chemicals or waterPlease note that securing the indicator to the control panel will provide the indicator outside of the control panel the IP65 protection.
- When installing or removing the indicator, be sure to turn off all the external power supplies used beforehand.

Precautions on wiring

WARNING

- When wiring the indicator, be sure to turn off all the external power supplies used beforehand.
- When wiring is complete, be sure to attach the terminal block cover provided with the indicator.
- Be sure to earth ground the indicator.

CAUTION

- Do not clamp control wires or communication cables with power lines, or do not place them close to power lines.
- Place the load cell cable sufficiently away from high frequency circuits such as high voltage power lines and inverter load circuit.

2. PART NAMES

2.1. Front Panel

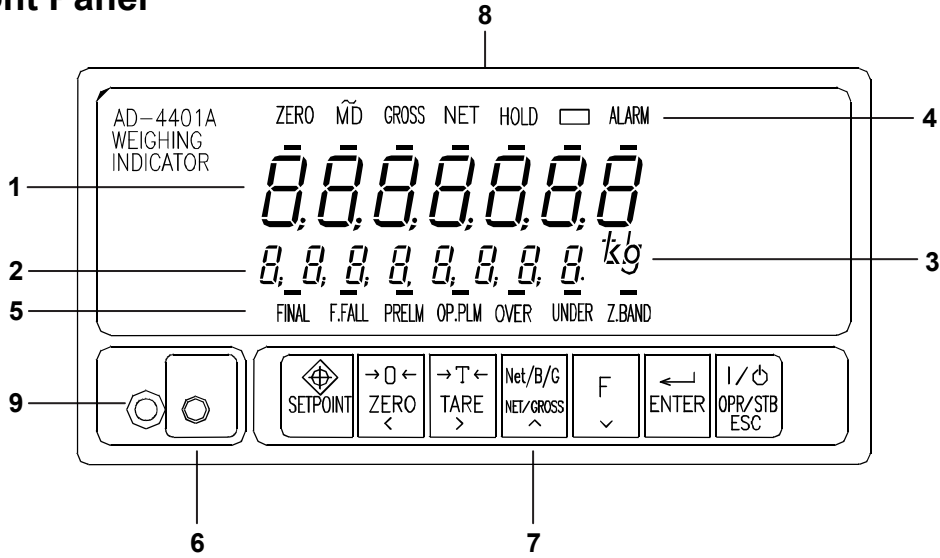

	No.	Name																								
Numerical Display	1	Main																								
	2	Sub																								
	3	Unit																								
Status Display (Upper)	4	ZERO STABLE (MD: Motion detection) GROSS NET HOLD FUNCTION <input type="checkbox"/> (FncF-05) ALARM																								
Status Display (Lower)	5	<table border="1"> <thead> <tr> <th>Normal batching</th> <th>Loss-in-weight batching</th> <th>Check weighing</th> </tr> </thead> <tbody> <tr> <td>Final weight</td> <td>Final weight</td> <td>Near-zero (Z.BAND)</td> </tr> <tr> <td>Free fall</td> <td>Free fall</td> <td>Lo-Lo</td> </tr> <tr> <td>Preliminary</td> <td>Preliminary</td> <td>Lo</td> </tr> <tr> <td>Optional preliminary</td> <td>Full</td> <td>Go</td> </tr> <tr> <td>Overweight</td> <td>Overweight</td> <td>Hi</td> </tr> <tr> <td>Underweight</td> <td>Underweight</td> <td>Hi-Hi</td> </tr> <tr> <td>Near-zero (Z.BAND)</td> <td>Near-zero (Z.BAND)</td> <td></td> </tr> </tbody> </table>	Normal batching	Loss-in-weight batching	Check weighing	Final weight	Final weight	Near-zero (Z.BAND)	Free fall	Free fall	Lo-Lo	Preliminary	Preliminary	Lo	Optional preliminary	Full	Go	Overweight	Overweight	Hi	Underweight	Underweight	Hi-Hi	Near-zero (Z.BAND)	Near-zero (Z.BAND)	
		Normal batching	Loss-in-weight batching	Check weighing																						
Final weight	Final weight	Near-zero (Z.BAND)																								
Free fall	Free fall	Lo-Lo																								
Preliminary	Preliminary	Lo																								
Optional preliminary	Full	Go																								
Overweight	Overweight	Hi																								
Underweight	Underweight	Hi-Hi																								
Near-zero (Z.BAND)	Near-zero (Z.BAND)																									
		Attach the accessory status label when performing loss-in-weight batching or check weighing.																								
Key Switches	6	CAL (Calibration) key																								
	7	SETPOINT ZERO TARE NET/GROSS Function (FncF-02) ENTER ON/OFF																								
Other	8	Rating label (Accessory)																								
	9	Sealing cover																								

2.2. Rear Panel

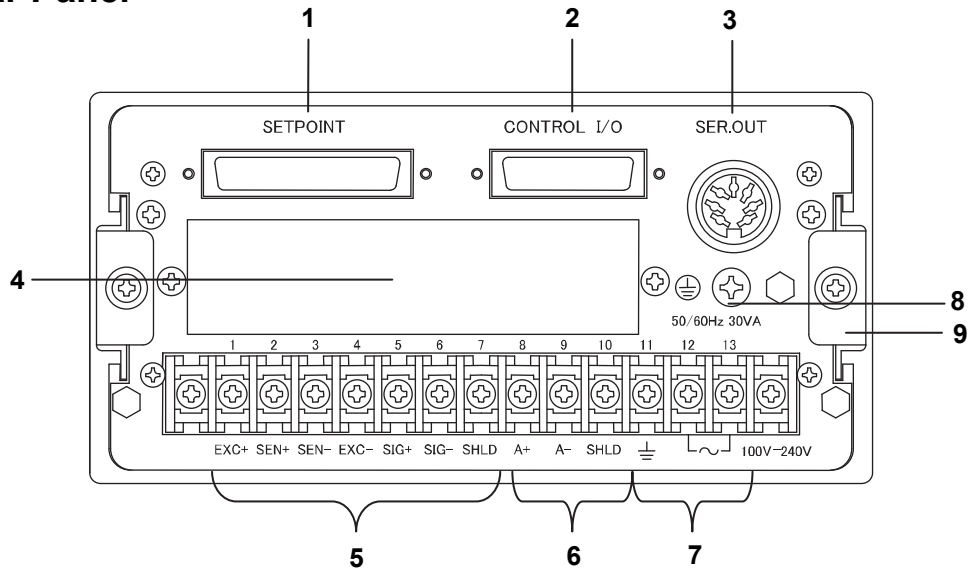

No.	Name
1	SETPOINT input connector
2	CONTROL I/O connector
3	SER.OUT (Standard serial output) connector
4	Option slot
5	Load cell input terminal block
6	Optional analog 4-20 mA output terminal block
7	AC power input terminal block
8	Protective conductor terminal
9	Slide rail

2.3. Accessories

Name	Quantity
Terminal block cover	1
Terminal block cover securing screw	2
Connector for the CONTROL I/O	1
Connector for the SER.OUT	1
Panel mount packing	1
Rubber foot	4
Rating label	1
Status label	1

3. INSTALLATION TO CONTROL PANEL

Make a hole in a control panel as shown below.

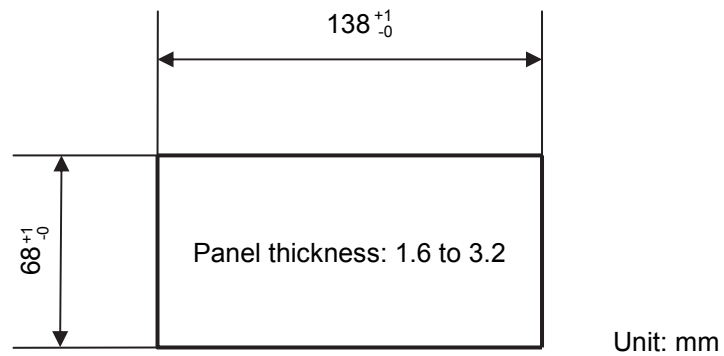

Remove the slide rails on both sides and insert the AD-4401A with the accessory packing through the hole into the panel.

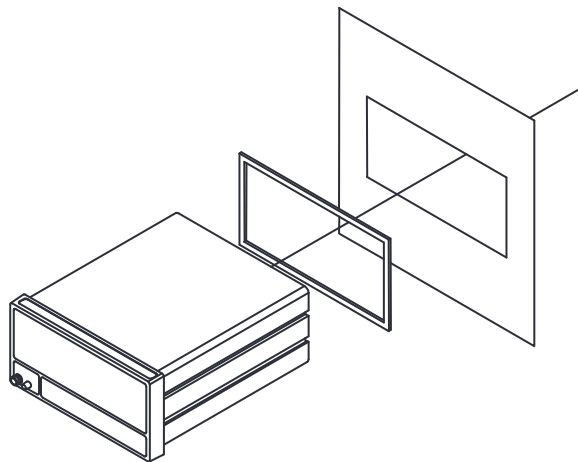

Insert the slide rails from behind.

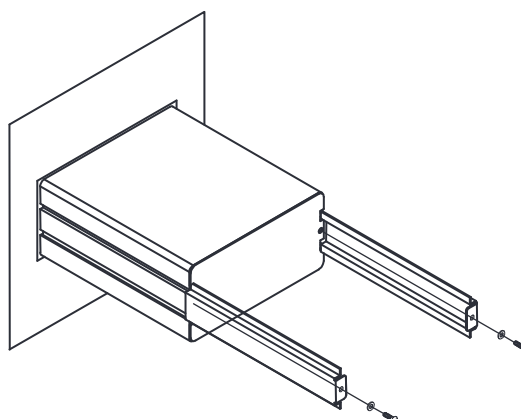

4. CONNECTION TO POWER SUPPLY

4.1. AC Power Input Terminal Assignment

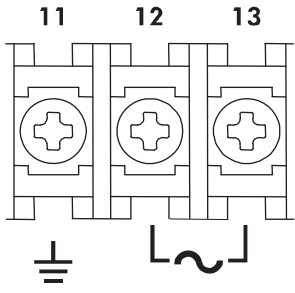

Use a solderless terminal with a width of 6.2 mm or less.

Terminal No.	Symbol	Description
11		Ground terminal
12		AC power input (Neutral) Earthed conductive part
13		AC power input (Live) Unearthed conductive part

4.2. Connection Diagram

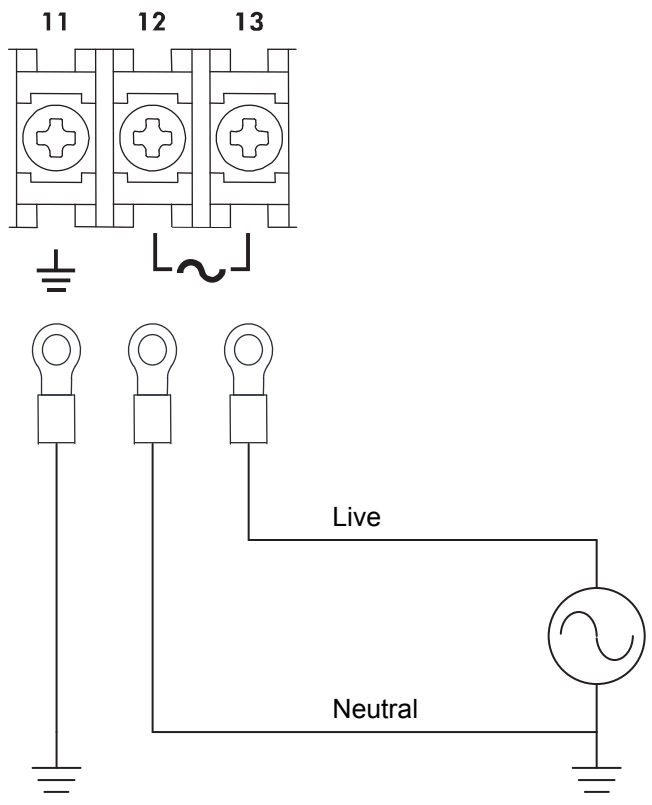

5. CONNECTION TO LOAD CELL

5.1. Load Cell Input Terminal Assignment

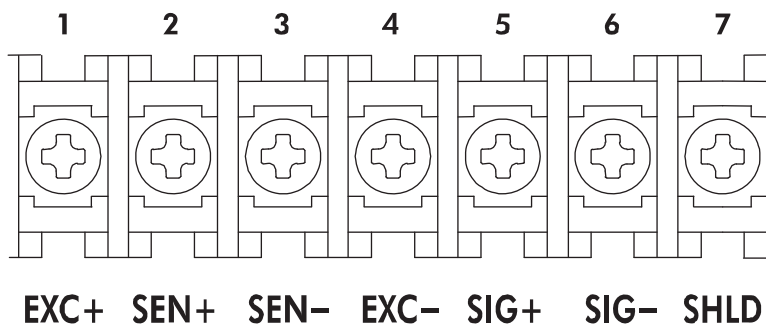

Use a solderless terminal with a width of 6.2 mm or less.

Terminal No.	Symbol	Description
1	EXC+	Load cell excitation voltage +
2	SEN+	Sensing input +
3	SEN-	Sensing input -
4	EXC-	Load cell excitation voltage -
5	SIG+	Load cell signal input +
6	SIG-	Load cell signal input -
7	SHLD	Frame ground

5.2. Connection Diagram

● 6-wire connection

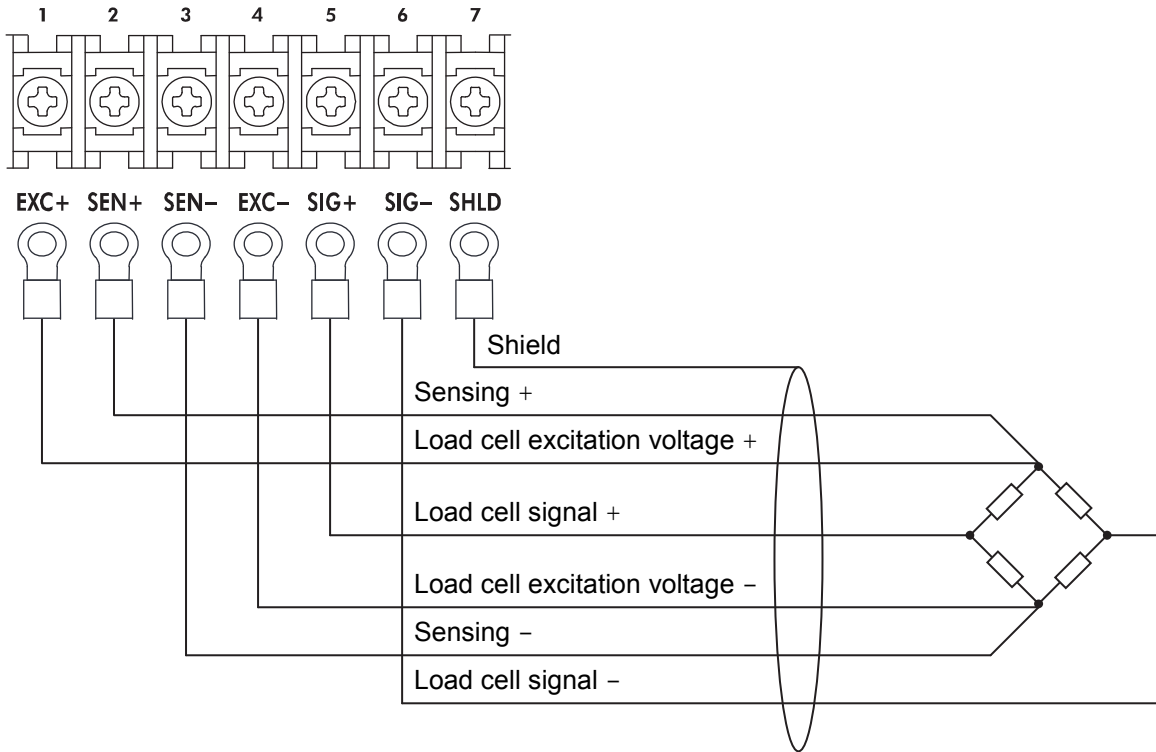

● 4-wire connection

As shown in the figure below, short-circuit the pins No.1 and No.2, and pins No.3 and No.4.

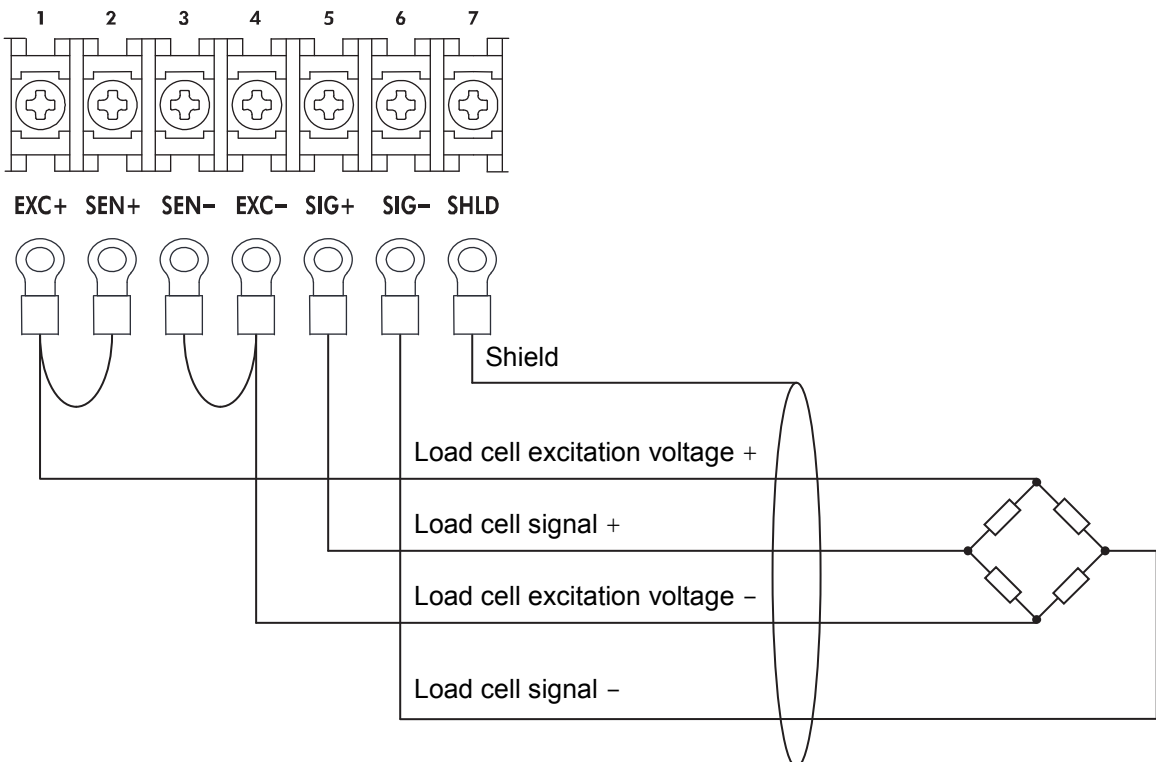

6. CALIBRATION

Calibrates the AD-4401A to convert the signal from the load cell to a mass value correctly.

6.1. Calibration Setting

Set the following calibration functions which are required for calibration using calibration weights.

For the function setting procedure, refer to "20.1. Calibration Function Setting".

●Unit: (CALF-01)

Select the unit of the scale.

0: None, 1: g, 2: kg, 3: t, 4: lb (For USA only)

●Decimal point position: (CALF-02)

Select the position of a decimal point.

0: 0 (No decimal point)
1: 0.0
2: 0.00
3: 0.000
4: 0.0000

●Minimum division: (CALF-03)

Set the minimum division of the scale.

1, 2, 5, 10, 20, 50 d

●Maximum capacity: (CALF-04)

Set the maximum weighing capacity of the scale.

0 to 999999

Once the calibration using calibration weights has been completed, the following calibration functions are automatically set.

●Load cell signal voltage at zero calibration: (CALF-15)

●(Load cell signal voltage at span calibration – CALF-15) × CALF-17 / Calibration weight value at span calibration: (CALF-16)

●Maximum capacity at span calibration: (CALF-17)

●Calibration weights at span calibration via Modbus: (CALF-23)

Calibration is also performed without calibration weights by setting the load cell signal voltage corresponding to the calibration weight value (Digital span).

6.2. Calibration Using Calibration Weights

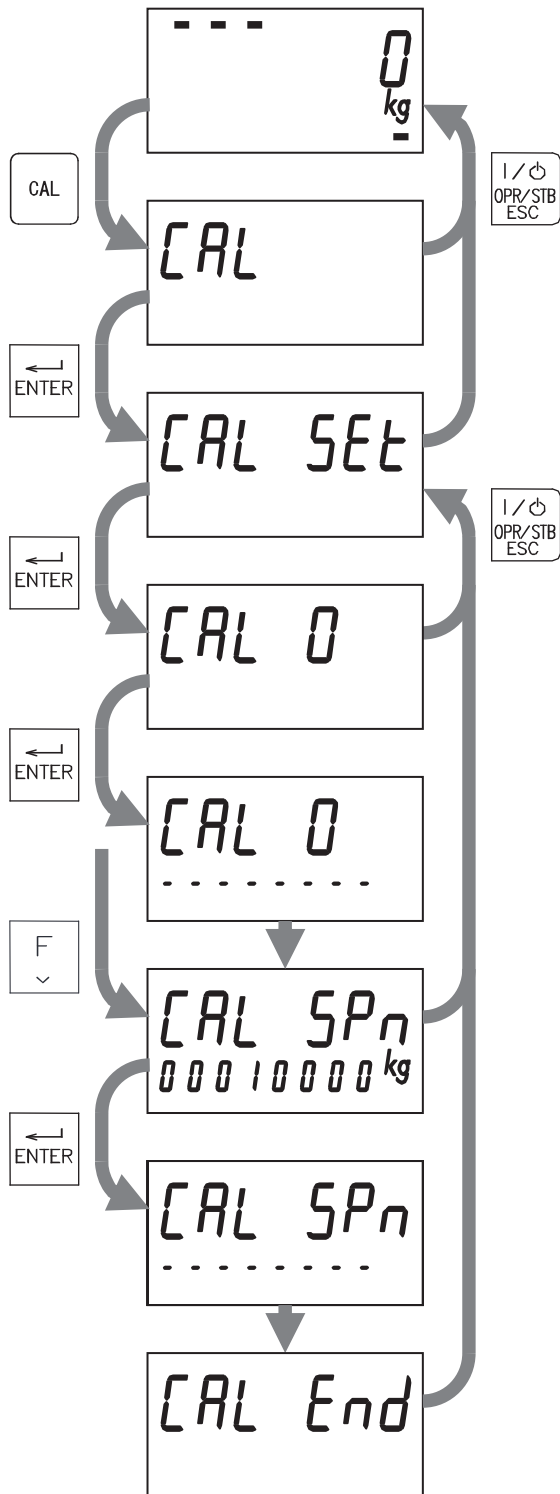

Press the CAL key in the normal mode.

When "CAL" is displayed, press the ENTER key.

When "CAL Set" is displayed, press the ENTER key.

Zero calibration

Press the ENTER key when the STABLE (MD) status is turned OFF.

Dashes are displayed in the sub-display and zero calibration is performed.

Note: When the Function key is pressed, the AD-4401A proceeds to the span calibration without performing zero calibration.

Span calibration

Set the calibration weight value in the sub-display.

Press the ENTER key when the STABLE (MD) status is turned OFF.

Dashes are displayed in the sub-display and span calibration is performed.

Press the ON/OFF key twice to return to the normal mode.

Error List

C Err	Description
2	The load cell signal voltage at zero calibration exceeds 2 mV/V. Check if unnecessary load is applied to the load cell.
3	The load cell signal voltage at zero calibration is less than 0 mV/V. Check if load cell connections of SIG+ and SIG- are not reversed.
4	The calibration weight value that is set in the span calibration exceeds the maximum capacity. Set the calibration weight value to less than the maximum capacity.
5	The calibration weight value that is set in the span calibration is less than the minimum division. Set the calibration weight value to greater than the minimum division.
7	The load cell signal voltage at span calibration is less than that at zero calibration. Check the load cell wiring.
8	The load cell signal voltage at span calibration exceeds 3.2 mV/V. Check if unnecessary load is applied to the load cell.

7. BASIC WEIGHING FUNCTIONS

When the AD-4401A is powered ON, all the segments of the display turn ON and OFF for checking the display. Then the AD-4401 is in the normal mode and starts weighing.

If the AD-4401A is powered OFF in the OFF mode (with the display OFF), the AD-4401A is in the OFF mode when powered ON.

For the function setting procedure, refer to "20.1. Calibration Function Setting" and "20.2. General Function Setting".

●Main display

The contents in the main display in the normal mode are as follows.

- Weight value
- Positive overload



- Negative overload



●Sub-display

Select the function of the sub-display (FncF-04) from the following:

Gross value, Net value, Tare value, Final weight, Total weight, Number of accumulations, Weighing sequence error

●Display OFF (OFF mode)

Turn the display OFF.

Operation: ON/OFF key

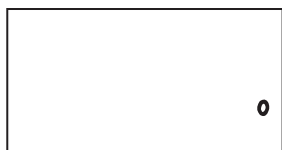

●Zero setting

The gross value is set to zero when the weight value is within the zero setting range (CALF-05).

Operation: ZERO key, Control input

Setting: Tare and zero setting at unstable weight. (CALF-10)

●Zero clear

The zero setting value is cleared.

Operation: Function key (FncF-02), Control input

●Zero tracking

The gross value is set to zero automatically when the zero tracking time (CALF-06) has passed while the gross value is maintained within the zero tracking width (CALF-07).

Note: The function is enabled only when the gross value is within the zero setting range (CALF-05).

●Tare

The current gross value is saved as a tare value and the net value is set to zero.

Operation: TARE key, Control input

Setting: Tare and zero setting at unstable weight (CALF-10) / Tare at negative gross value (CALF-11)

●Tare clear

The tare value is cleared.

Operation: Function key (FncF-02), Control input

●Gross/Net value selection

The weight value display method is selected, gross value or net value. The GROSS status turns ON when the gross value is displayed. The NET status turns ON when the net value is displayed.

Operation: NET/GROSS key, Control input

●Zero

Center of zero is detected and the ZERO status turns ON when the gross value is within 1/4 of the minimum division.

●Stable

Stability is detected when the weight value is maintained within the stability detection width (CALF-09) during the stability detection time (CALF-08). The STABLE (MD) status turns OFF. The control output that is set to "Stable" turns ON.

●Hold

The weight value is temporarily locked / released. The HOLD status turns ON while the weight value is locked.

Operation: Function key (FncF-02), Control input

Select a hold function (FncF-08) from the following:

- Normal hold: The value when the holding operation is performed is locked.
- Peak hold: The maximum value after the holding operation is locked.

Setting: Comparison at hold (FncF-09)

●Manual print

Data is output from the standard serial output or options (BCD, RS-232C, RS-422/485).

Operation: Function key (FncF-02), Control input

●Accumulation

The net value is accumulated on the total weight and the number of accumulations is updated.

Operation: Function key (FncF-02), Control input

●Total clear

The total weight and the number of accumulations are cleared.

Operation: Function key (FncF-02), Control input

●Undoing accumulation

The weight value accumulated last is subtracted from the total weight.

Operation: Function key (FncF-02), Control input

●Alarm

Select the condition to turn the ALARM status ON (FncF-10) from the following:

- Overload
- Total weight / number of accumulations overflow
- Zero setting error
- Tare error
- Weighing sequence error

8. BATCH WEIGHING FUNCTIONS

Batch weighing is a procedure to automatically weigh the final weight.

Select a weighing mode (CALF-14) from the following:

- 1: Simple comparison normal batching
- 2: Simple comparison loss-in-weight batching
- 3: Normal batching (default)
- 4: Loss-in-weight batching

8.1. Normal Batching

●Weighing start

Operation: Function key (FncF-02), Control input

Setpoint values: Final weight, Free fall, Preliminary, Optional preliminary, Overweight, Underweight, Near-zero

Feeding process

1. The weighing start input is detected.
2. When the weighing start input delay time (Sq F-09) has passed, the large flow, medium flow and small flow outputs turn ON.
3. When the large flow comparison disable time (Sq F-10) has passed and the net value has exceeded the optional preliminary value, the large flow output turns OFF.
4. When the medium flow comparison disable time (Sq F-11) has passed and the net value has exceeded the preliminary value, the medium flow output turns OFF.
5. When the small flow comparison disable time (Sq F-12) has passed and the net value has exceeded the free fall value, the small flow output turns OFF.
6. When the judging delay time (Sq F-13) has passed and the net value is stable (Sq F-07), the net value is judged.

End of the feeding process

7. The weighing end output turns ON and the OK/Over/Under output of the judgment result turns ON.
Setting: OK/Over/Under output timing (Sq F-06)
8. When the weighing end output time (Sq F-14) has passed, the weighing end output turns OFF and the OK/Over/Under output of the judgment result turns OFF.

●Discharge start

Operation: Function key (FncF-02), Control input

Discharging process

1. The discharge start input is detected.
2. When the discharge start input delay time (Sq F-18) has passed, the discharge output turns ON.
3. When the gross value is below the near-zero value and the discharge end delay time (Sq F-19) has passed, the discharge output turns OFF.

●Near-zero

When the weight value is compared with the setpoint and the condition is met, the control output turns ON.

Condition	Control output
Gross value \leq Near-zero	Near-zero

Timing chart

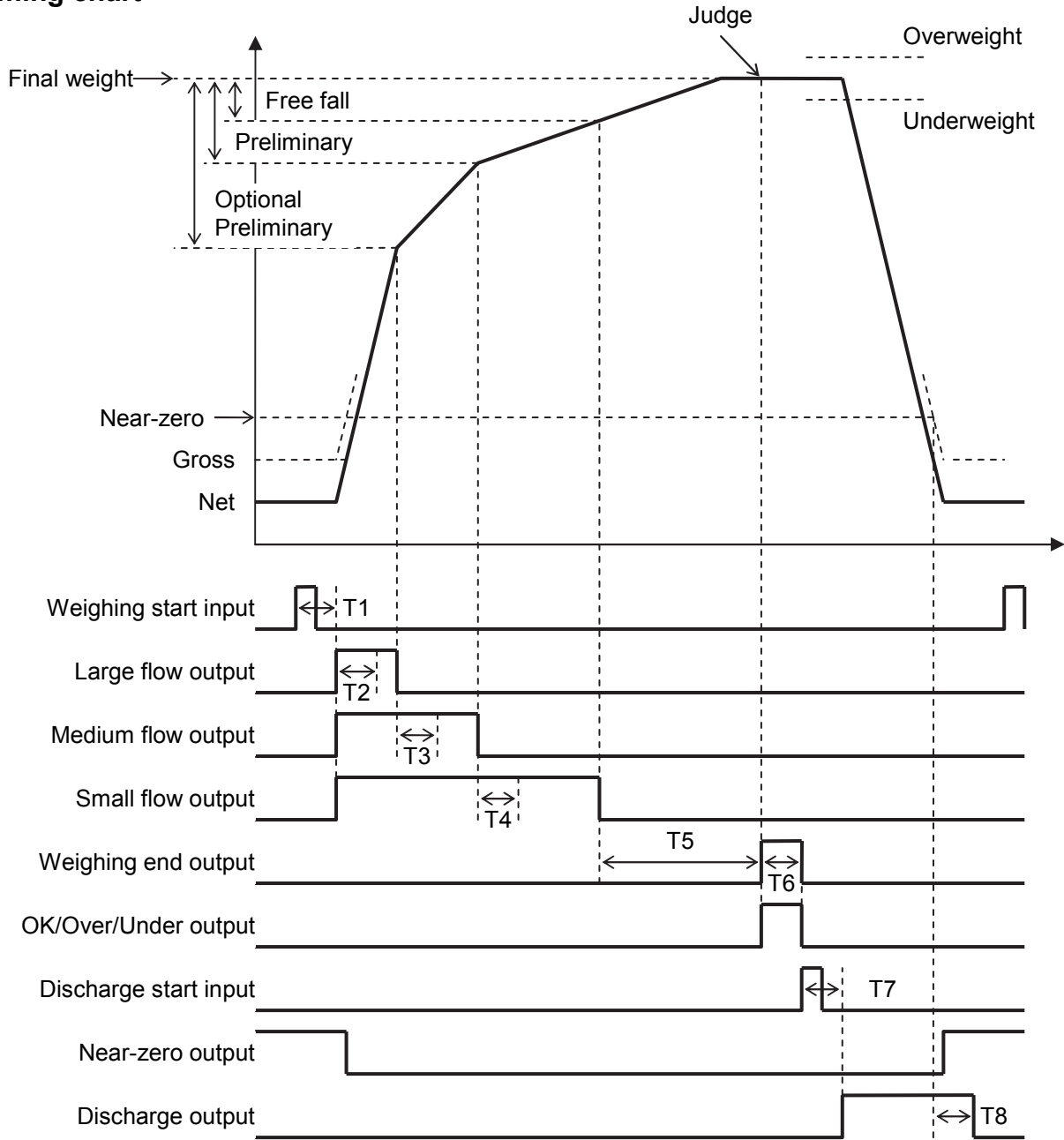

- T1: Weighing start input delay time
- T2: Large flow comparison disable time
- T3: Medium flow comparison disable time
- T4: Small flow comparison disable time
- T5: Judging delay time
- T6: Weighing end output time
- T7: Discharge start input delay time
- T8: Discharge end delay time

● Correction flow

When the judgment result after the feeding process is underweight, the following is automatically performed up to the maximum number of correction flow (Sq F-08) to compensate for the underweight value.

1. When the net value is judged to be underweight, the small flow output turns ON.
2. When the correction flow ON time (Sq F-16) has passed, the small flow output turns OFF.
3. When the correction flow OFF time (Sq F-17) has passed and the net value is stable (Sq F-07), the net value is judged.

Timing chart

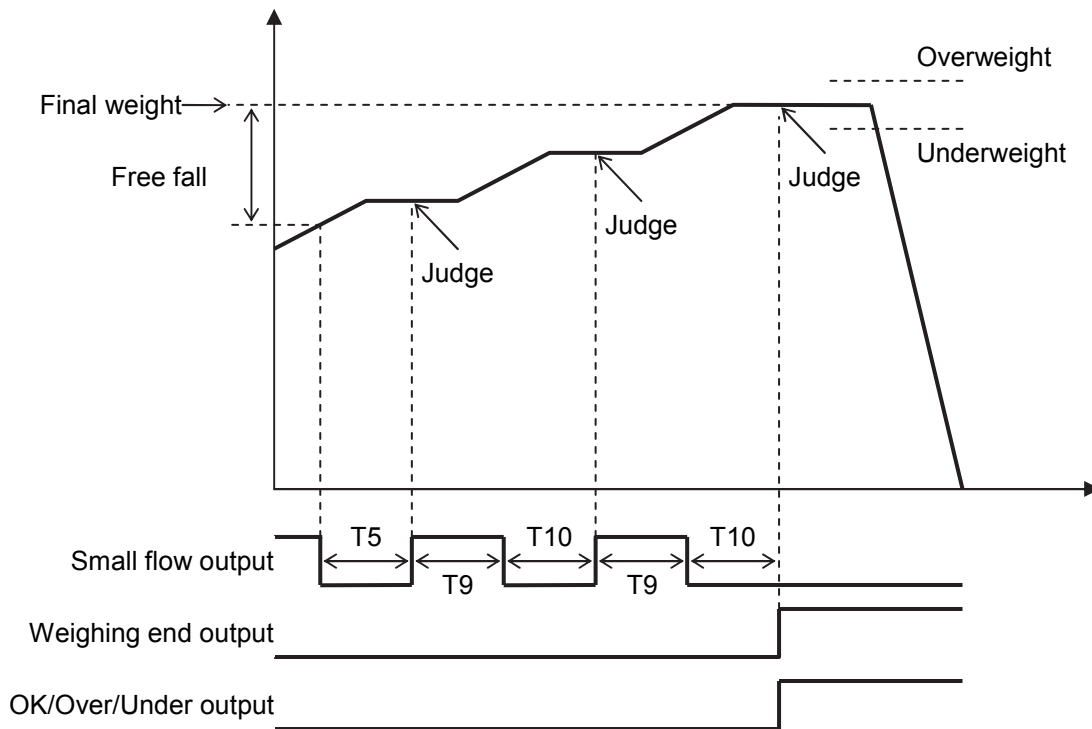

T5: Judging delay time
T9: Correction flow ON time
T10: Correction flow OFF time

8.2. Loss-in-weight Batching

●Weighing start

Operation: Function key (FncF-02), Control input

Setpoint values: Final weight, Free fall, Preliminary, Full, Overweight, Underweight, Near-zero

Feeding process

1. The weighing start input is detected.
2. When the weighing start input delay time (Sq F-09) has passed, the medium flow and small flow outputs turn ON.
3. When the medium flow comparison disable time (Sq F-11) has passed and the – net value has become below the preliminary value, the medium flow output turns OFF.
4. When the small flow comparison disable time (Sq F-12) has passed and the – net value has exceeded the free fall value, the small flow output turns OFF.
5. When the judging delay time (Sq F-13) has passed and the net value is stable (Sq F-07), the net value is judged.

End of the feeding process

6. The weighing end output turns ON and the OK/Over/Under output of the judgment result turns ON.
Setting: OK/Over/Under output timing (Sq F-06)
7. When the weighing end output time (Sq F-14) has passed, the weighing end output turns OFF and the OK/Over/Under output of the judgment result turns OFF.

●Near-zero and full

When the weight value is compared with the setpoint and the condition is met, the control output turns ON.

Condition	Control output
Net value \leq Near-zero	Near-zero
Gross value \geq Full	Full

Timing chart

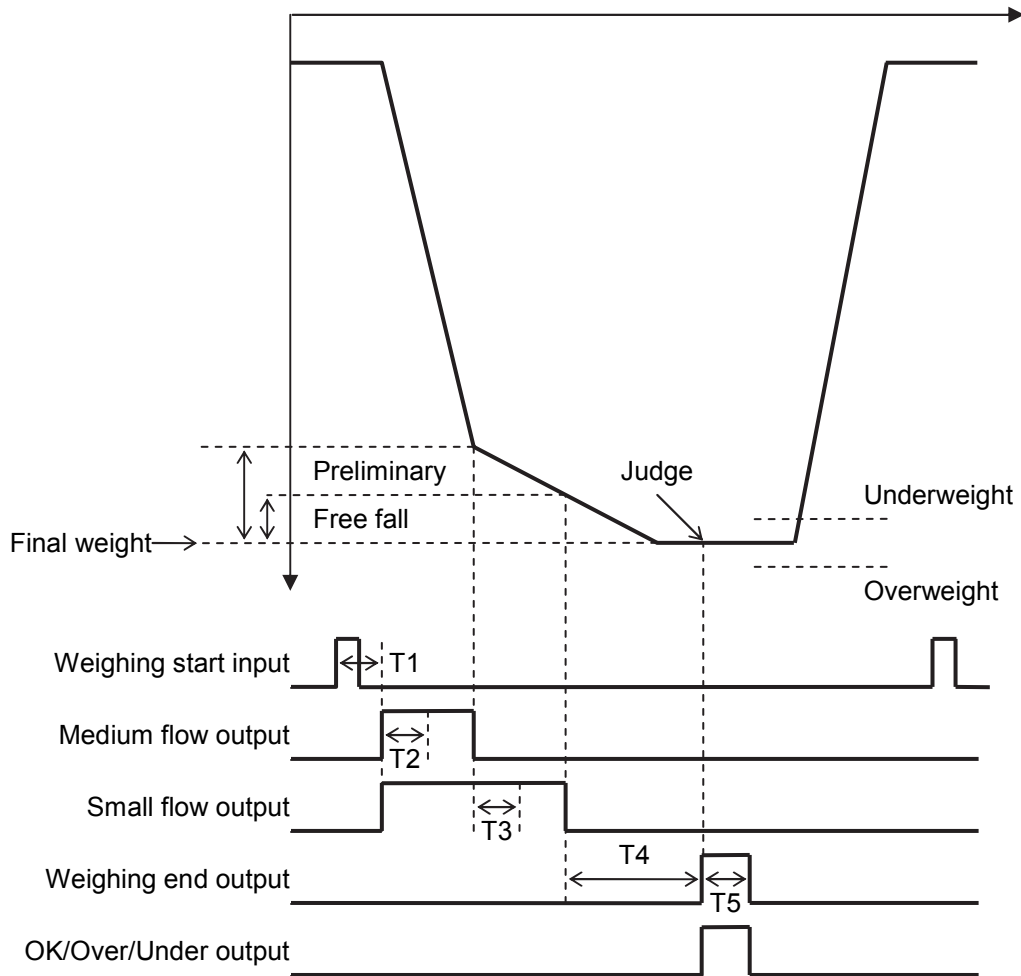

T1: Weighing start input delay time

T2: Medium flow comparison disable time

T3: Small flow comparison disable time

T4: Judging delay time

T5: Weighing end output time

● Correction flow

When the judgment result after the feeding process is underweight, the following is automatically performed up to the maximum number of correction flow (Sq F-08) to compensate for the underweight value.

1. When the net value is judged to be underweight, the small flow output turns ON.
2. When the correction flow ON time (Sq F-16) has passed, the small flow output turns OFF.
3. When the correction flow OFF time (Sq F-17) has passed and the net value is stable (Sq F-07), the net value is judged.

Timing chart

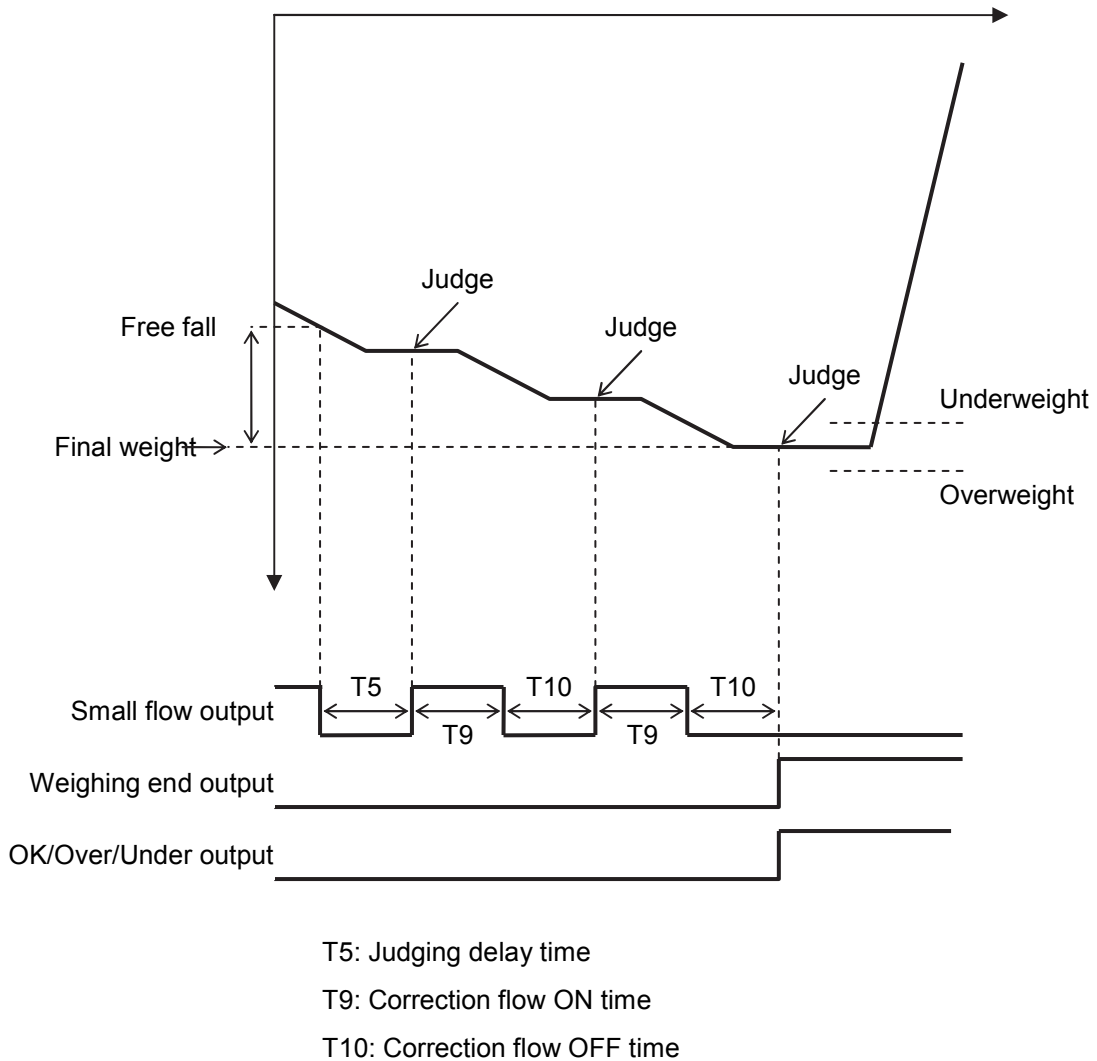

8.3. Sequential Weighing Functions

●Automatic free fall correction

Under the following conditions, the correct free fall value is automatically set.

- The weight value after the feeding process is within the final value \pm automatic free fall correction range (Sq F-04).
- The minimum small flow time for the automatic free fall correction (Sq F-05) has passed.

Select an automatic free fall correction method (Sq F-03) from the following.

- Moving average of last four weighings
- Fuzzy

●Automatic accumulation

When the weighing end output turns ON after the feeding process, the weight value is accumulated on the total weight.

Select the condition to perform the automatic accumulation (SqF-02) from the following.

- Accumulates only when the judgment result is OK.
- Accumulates regardless of the judgment result.

●Automatic print

When the weighing end output turns ON after the feeding process, data is output from the standard serial output (Si F-02) or options (bCdF-02, rS F-02).

●Emergency stop

The large flow, medium flow and small flow outputs turn OFF, the weighing sequence error output turns ON and the indicator waits for the next weighing start input.

Operation: Function key (FncF-02), Control input

●Flow timeout error/Discharge timeout error

When the duration from the flow output ON to the weighing end output ON has exceeded the flow timeout time (Sq F-15), the large flow, medium flow and small flow outputs turn OFF and the weighing sequence error output turns ON

When the duration from the discharge output ON to the weight value becoming near-zero has exceeded the discharge timeout time (Sq F-20), the discharge output turns OFF and the weighing sequence error output turns ON.

●Weighing sequence errors

When a sequence error is detected, the detected sequence number is displayed in the sub-display. (FncF-04)

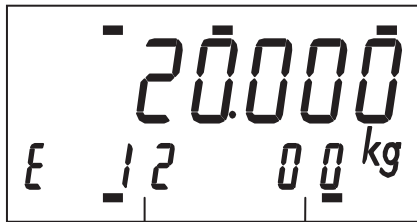

Current sequence number

Number of the sequence in which an error is detected.

Sequence No.	Description
00	Waits for the weighing start input.
01	Automatic tare
02	Weighing start input delay time (1 s) after automatic tare
03	Starts the weighing start input delay.
04	Compares the weight value with the setpoint.
05	Waits for the weighing start input delay time to pass.
06	Turns the large flow/medium flow/small flow outputs ON.
07	Waits for the large flow comparison disable time to pass.
08	Waits for the weight value to exceed the optional preliminary value.
09	Turns the large flow output OFF and waits for the medium flow comparison disable time to pass.
10	Waits for the weight value to exceed the preliminary value.
11	Turns the medium flow output OFF and waits for the small flow comparison disable time to pass.
12	Waits for the weight value to exceed the free fall value.
13	Waits for the judging delay time to pass.
14	Waits for the weight value to be stable.
15	Judges if the correction flow is required.
16	Judges the weight value.
17	Waits for the weight value to be near-zero.
30	Starts the correction flow.
31	Turns the small flow output ON for correction.
32	Waits for the correction flow ON time to pass and turns the small flow output OFF.
33	Waits for the correction flow OFF time to pass.
34	Judges the correction flow value.
35	Ends the correction flow.
50	Waits for the discharge start input.
51	Waits for the discharge start input delay time to pass.
52	Turns the discharge output ON.
53	Waits for the weight value to be below the near-zero value.
54	Waits for the discharge end delay time to pass.
55	Turns the discharge output OFF.

8.4. Simple Comparison Normal Batching

When the weight value is compared with the setpoint and the condition is met, the control output turns ON.

Condition	Control output
Gross value \leq Near-zero	Near-zero
Net value \geq Final - Optional preliminary	Large flow
Net value \geq Final - Preliminary	Medium flow
Net value \geq Final - Free fall	Small flow
Net value $>$ Final - Underweight	Underweight
Net value $>$ Final + Overweight	Overweight
Final + Overweight \geq Net value \geq Final - Underweight	OK

Timing chart

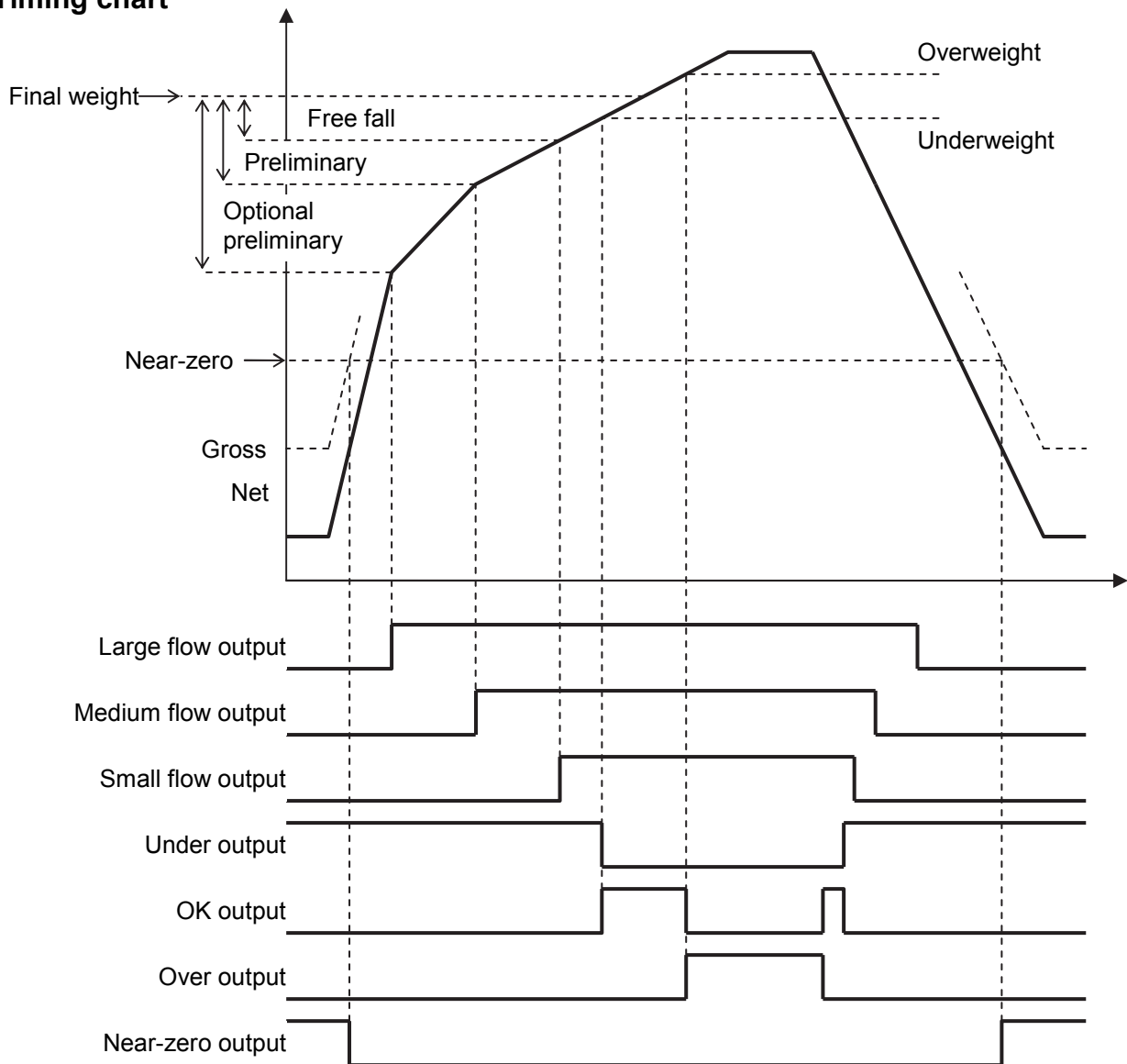

8.5. Simple Comparison Loss-in-weight Batching

When the weight value is compared with the setpoint and the condition is met, the control output turns ON.

Condition	Control output
Weight value \leq Near-zero	Near-zero
Gross value \geq Full	Full
-Net value \geq Final - Preliminary	Medium flow
-Net value \geq Final - Free fall	Small flow
-Net value $<$ Final - Underweight	Underweight
-Net value $>$ Final + Overweight	Overweight
Final + Overweight \geq -Net value \geq Final - Underweight	OK

Timing chart

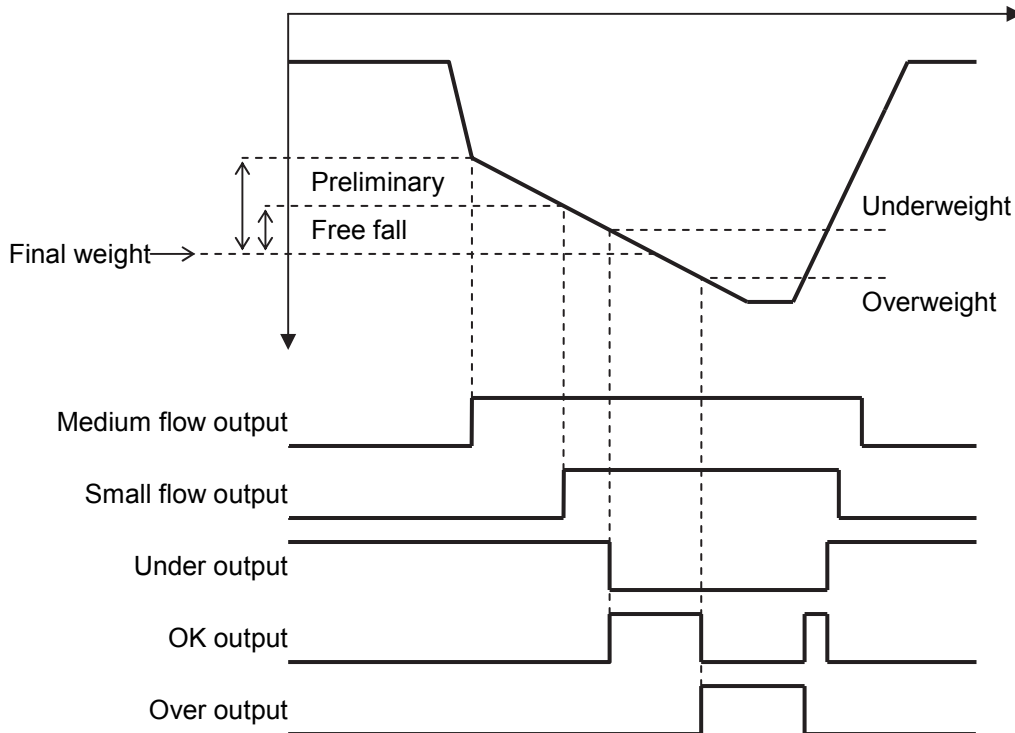

8.6. Simple Comparison Functions

● Automatic print

When the weight value is five times the minimum division or more and the large flow, medium flow and small flow outputs turn ON, data is output once from the standard serial output or options. To output again, wait for the -weight value to be four times the minimum division or less.

9. CHECK WEIGHING FUNCTIONS

Check weighing separates the weight values into a maximum of five stages.

Select a weighing mode (CALF-14) from the following.

- 5: Check weighing 1
- 6: Check weighing 2
- 7: Check weighing 3
- 8: Check weighing 4

9.1. Check Weighing 1

When the weight value is compared with the setpoint and the condition is met, the control output turns ON.

Condition	Control output
Gross value \leq Near-zero	Near-zero
Net value $>$ Hi-Hi limit	Hi-Hi
Net value $>$ Target + Hi limit	Hi
Target + Hi limit \geq Net value \geq Target - Lo limit	Go
Net value $<$ Target - Lo limit	Lo
Net value $<$ Lo-Lo limit	Lo-Lo

Timing chart

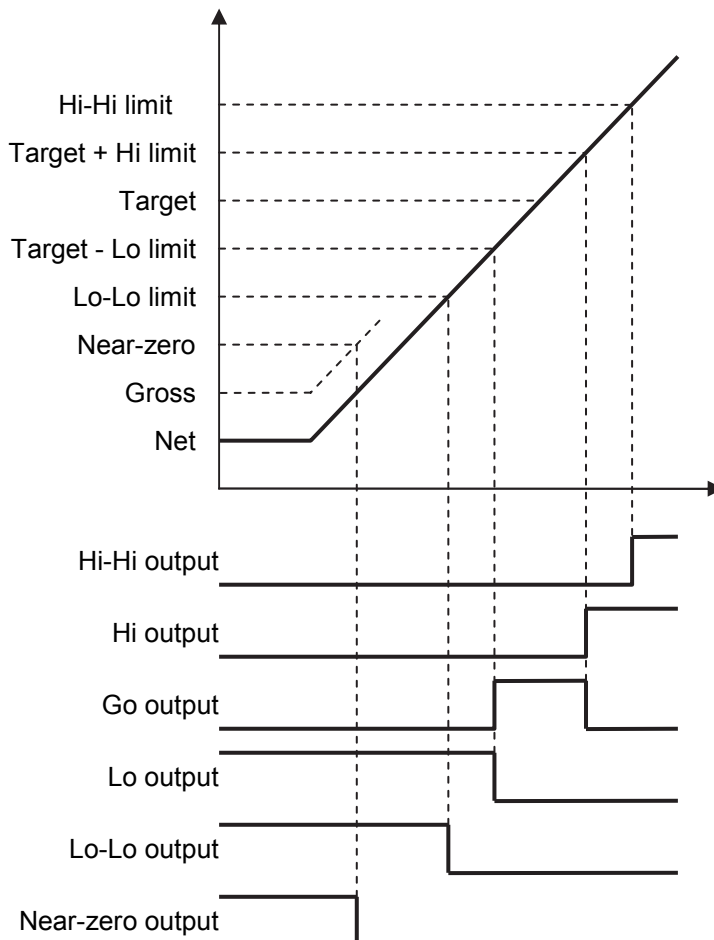

9.2. Check Weighing 2

When the weight value is compared with the setpoint and the condition is met, the control output turns ON.

Condition	Control output
Gross value \leq Near-zero	Near-zero
Net value $>$ Target + Hi-Hi limit	Hi-Hi
Target + Hi-Hi limit \geq Net value $>$ Target + Hi limit	Hi
Target + Hi limit \geq Net value \geq Target - Lo limit	Go
Target - Lo limit $>$ Net value \geq Target - Lo-Lo limit	Lo
Net value $<$ Target + Lo-Lo limit	Lo-Lo

Timing chart

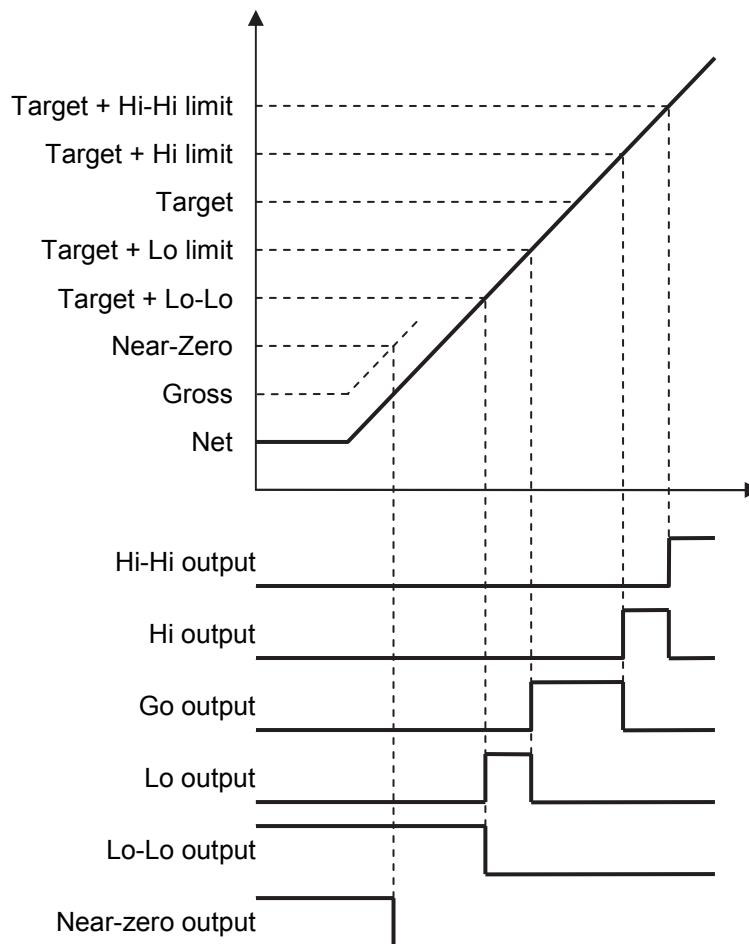

9.3. Check Weighing 3

When the weight value is compared with the setpoint and the condition is met, the control output turns ON.

Condition	Control output
Gross value \leq Near-zero	Near-zero
Net value $>$ Hi-Hi limit	Hi-Hi
Net value $>$ Hi limit	Hi
Hi limit \geq Net value \geq Lo limit	Go
Net value $<$ Lo limit	Lo
Net value $<$ Lo-Lo limit	Lo-Lo

Timing chart

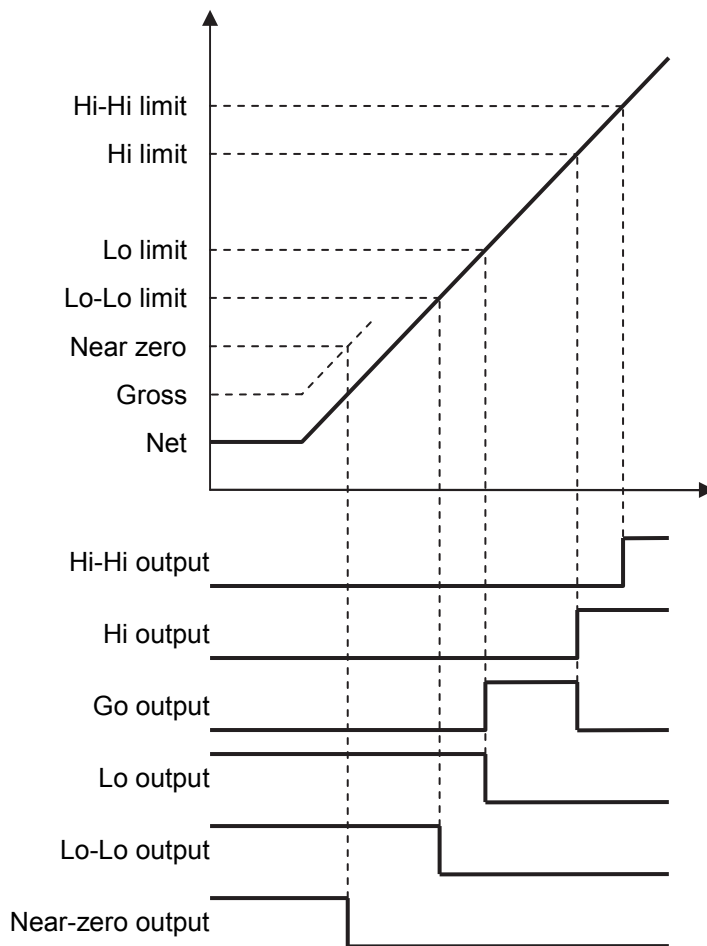

9.4. Check Weighing 4

When the weight value is compared with the setpoint and the condition is met, the control output turns ON.

Condition	Control output
Gross value \leq Near-zero	Near-zero
Net value $>$ Hi-Hi limit	Hi-Hi
Hi-Hi limit $>$ Net value \geq Hi limit	Hi
Hi limit $>$ Net value \geq Lo limit	Go
Lo limit $>$ Net value \geq Lo-Lo limit	Lo
Net value $<$ Lo-Lo limit	Lo-Lo

Timing chart

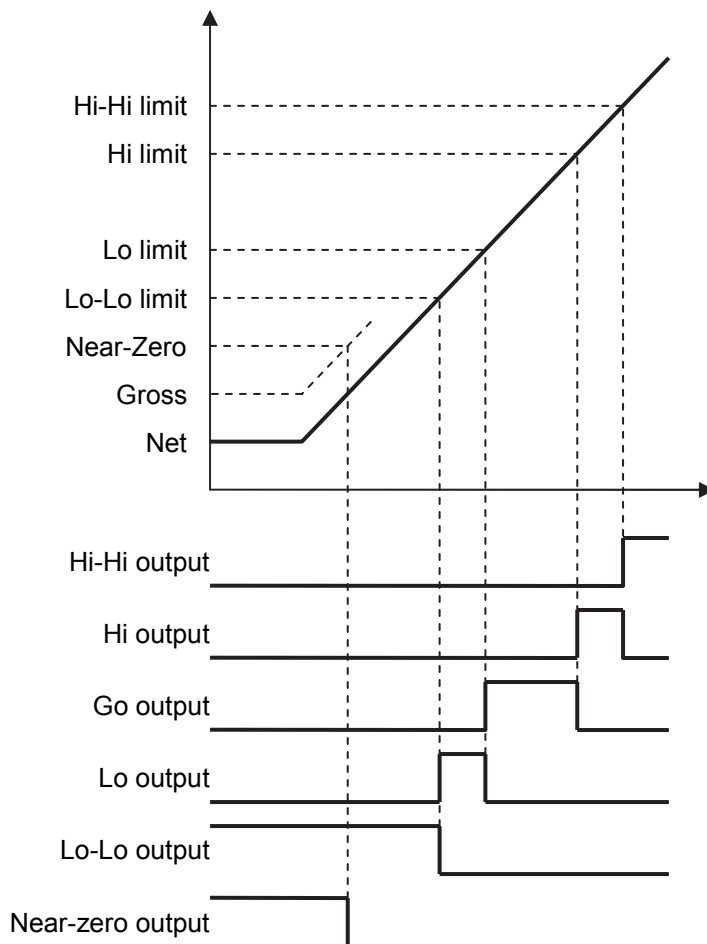

9.5. Check Weighing Functions

● Automatic print

When the weight value is five times the minimum division or more and is stable, data is output once from the standard serial output or options. To output again, wait for the weight value to be four times the minimum division or less.

10. CONTROL I/O

10.1. Pin Assignment

CONTROL I/O

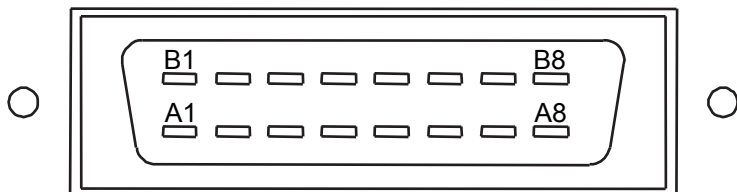

The applicable connector is an FCN-360 series 16-pin female connector manufactured by Fujitsu Component Limited or the equivalent.

An FCN-361J016 (connector) and an FCN-360C016 (cover) are provided with the indicator.

Pin No.	Description	Description	Pin No.
A1	Control input	Control output	B1
A2	Control input	Control output	B2
A3	Control input	Control output	B3
A4	Control input	Control output	B4
A5	Control input	Control output	B5
A6	Control input	Control output	B6
A7	Input common	Control output	B7
A8	Output common	Control output	B8

10.2. Connection Diagram

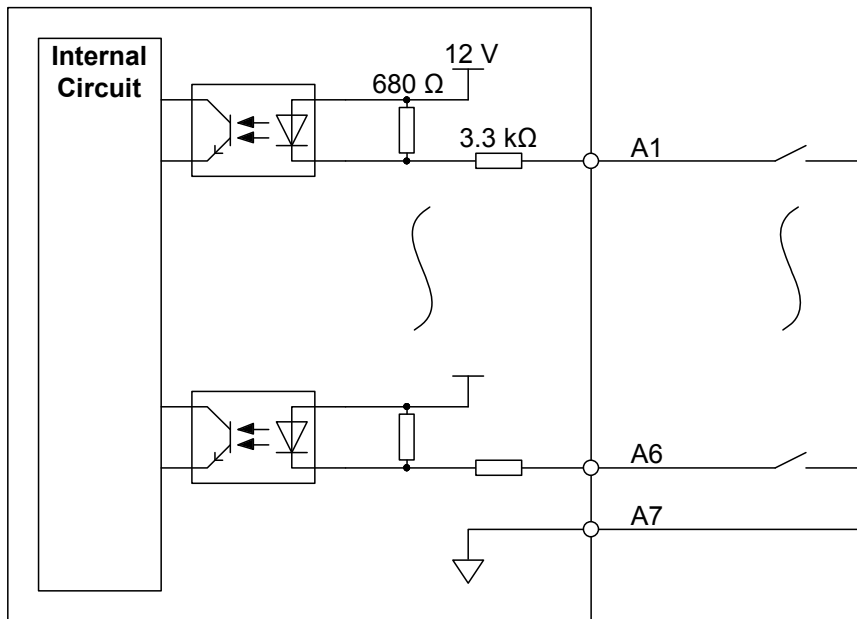

Control input

- ON voltage: 5 V or less
- ON current: 3 mA or more
- OFF current: 1 mA or less

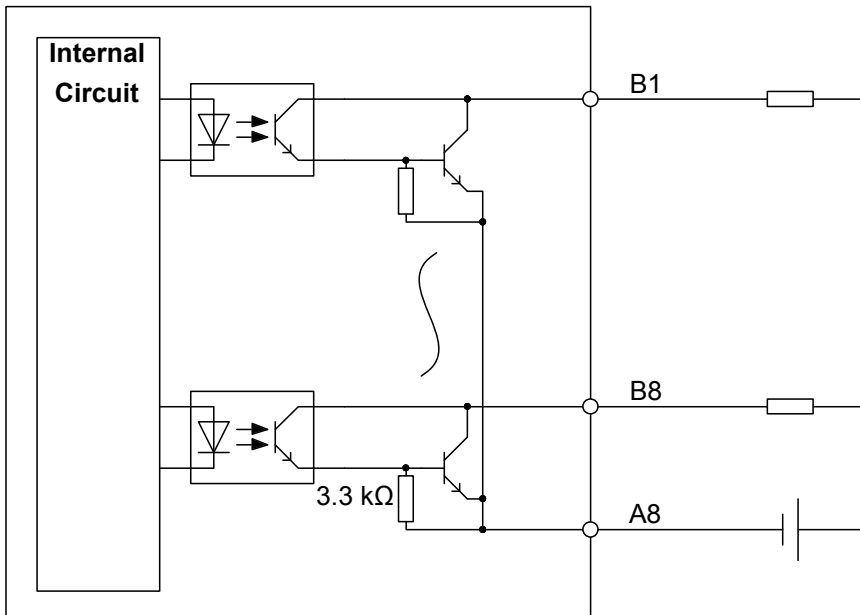

Control output

- Maximum load voltage: 30 VDC
- Maximum load current: 50 mA/point
- Voltage drop at ON: 1 V or less
- Leakage current at OFF: 0.1 mA or less

10.3. Control Input Method

Two methods of control input are available; edge detection and level detection.

Edge detection

Control input is performed when the control input is turned ON (short-circuit) from the OFF state (open-circuit).

The pulse width is 50 ms or more.

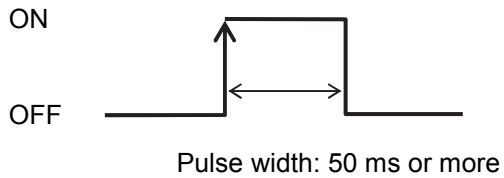

Level detection

Control input is performed while the control input is ON (short-circuit).

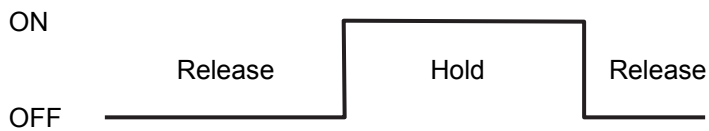

11. SETPOINT INPUT

Setpoints are set using the setpoint input from external devices.

Setpoints that cannot be set using the setpoint input are set using key switches.

11.1. Pin Assignment

SETPOINT

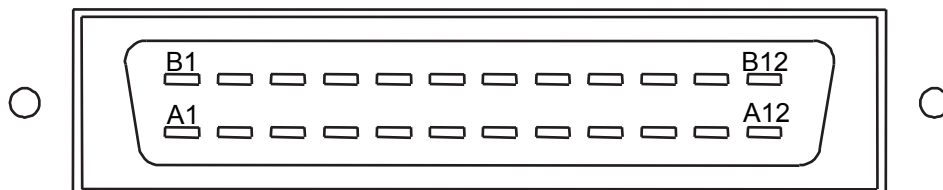

The applicable connector is an FCN-360 series 24-pin female connector manufactured by Fujitsu Component Limited or the equivalent.

The connector is not provided and must be prepared by the user.

The descriptions of the pin Nos. depend on the weighing mode (CALF-14) and the setpoint setting method (SP F-01) settings.

In addition, when the minimum division (CALF-03) is 10 d or more, the setpoint will be ten times the setting value.

Weighing mode = Normal batching, Loss-in-weight batching, Simple comparison normal batching, Simple comparison loss-in-weight batching

Setpoint setting method = 5-digit input from external devices

Pin No.	Description	Description	Pin No.
A1	BCD input 1	NC	B1
A2	BCD input 2	NC	B2
A3	BCD input 4	NC	B3
A4	BCD input 8	NC	B4
A5	Final weight 10 ⁰	NC	B5
A6	Final weight 10 ¹	NC	B6
A7	Final weight 10 ²	NC	B7
A8	Final weight 10 ³	NC	B8
A9	Final weight 10 ⁴	NC	B9
A10	NC	NC	B10
A11	NC	NC	B11
A12	NC	Shield	B12

Weighing mode = Normal batching, Loss-in-weight batching, Simple comparison normal batching, Simple comparison loss-in-weight batching

Setpoint setting method = 16-digit input from external devices

Pin No.	Description	Description	Pin No.
A1	BCD input 1	Preliminary 10 ⁰	B1
A2	BCD input 2	Preliminary 10 ¹	B2
A3	BCD input 4	Preliminary 10 ²	B3
A4	BCD input 8	Preliminary 10 ³	B4
A5	Final weight 10 ⁰	Overweight 10 ⁰	B5
A6	Final weight 10 ¹	Overweight 10 ¹	B6
A7	Final weight 10 ²	Underweight 10 ⁰	B7
A8	Final weight 10 ³	Underweight 10 ¹	B8
A9	Final weight 10 ⁴	NC	B9
A10	Free fall 10 ⁰	NC	B10
A11	Free fall 10 ¹	NC	B11
A12	Free fall 10 ²	Shield	B12

Weighing mode = Check weighing 1, Check weighing 2

Setpoint setting method = 16-digit input from external devices

Pin No.	Description	Description	Pin No.
A1	BCD input 1	Hi limit 10 ³	B1
A2	BCD input 2	Hi limit 10 ⁴	B2
A3	BCD input 4	Lo limit 10 ⁰	B3
A4	BCD input 8	Lo limit 10 ¹	B4
A5	Target 10 ⁰	Lo limit 10 ²	B5
A6	Target 10 ¹	Lo limit 10 ³	B6
A7	Target 10 ²	Lo limit 10 ⁴	B7
A8	Target 10 ³	NC	B8
A9	Target 10 ⁴	NC	B9
A10	Hi limit 10 ⁰	NC	B10
A11	Hi limit 10 ¹	NC	B11
A12	Hi limit 10 ²	Shield	B12

Weighing mode = Check weighing 3

Setpoint setting method = 16-digit input from external devices

Pin No.	Description	Description	Pin No.
A1	BCD input 1	Hi limit 10 ³	B1
A2	BCD input 2	Hi limit 10 ⁴	B2
A3	BCD input 4	Lo limit 10 ⁰	B3
A4	BCD input 8	Lo limit 10 ¹	B4
A5	NC	Lo limit 10 ²	B5
A6	NC	Lo limit 10 ³	B6
A7	NC	Lo limit 10 ⁴	B7
A8	NC	NC	B8
A9	NC	NC	B9
A10	Hi limit 0 ⁰	NC	B10
A11	Hi limit 10 ¹	NC	B11
A12	Hi limit 10 ²	Shield	B12

Weighing mode = Check weighing 4

Setpoint setting method = 16-digit input from external devices

Pin No.	Description	Description	Pin No.
A1	BCD input 1	Lo limit 10 ⁰	B1
A2	BCD input 2	Lo limit 10 ¹	B2
A3	BCD input 4	Lo limit 10 ²	B3
A4	BCD input 8	Lo limit 10 ³	B4
A5	Hi-Hi limit 10 ⁰	Lo-Lo limit 10 ⁰	B5
A6	Hi-Hi limit 10 ¹	Lo-Lo limit 10 ¹	B6
A7	Hi-Hi limit 10 ²	Lo-Lo limit 10 ²	B7
A8	Hi-Hi limit 10 ³	Lo-Lo limit 10 ³	B8
A9	Hi limit 10 ⁰	NC	B9
A10	Hi limit 10 ¹	NC	B10
A11	Hi limit 10 ²	NC	B11
A12	Hi limit 10 ³	Shield	B12

11.2. Connection Diagram

Setpoint input is 4x16 key matrix input.

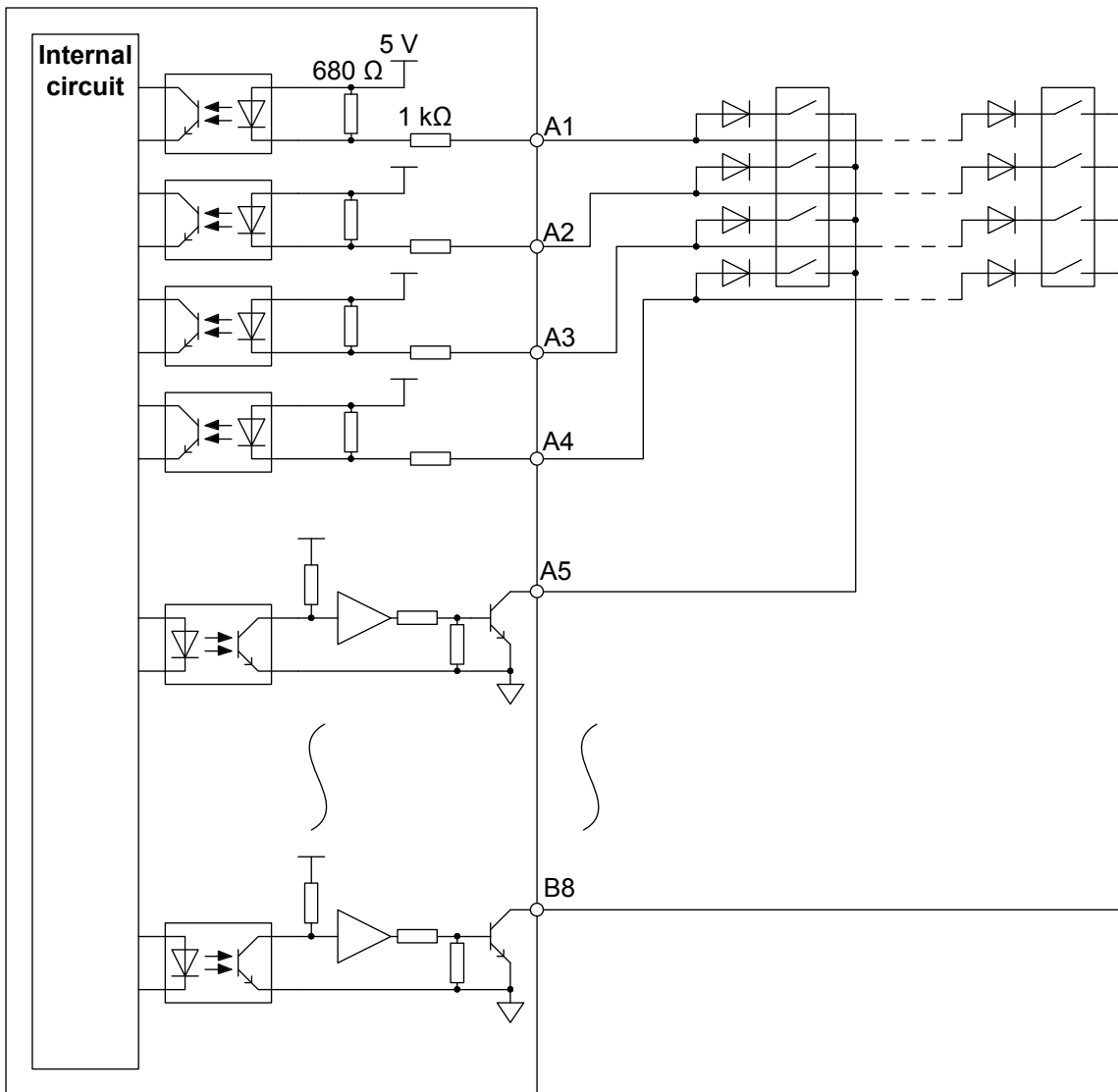

Key scan output

- Voltage drop at ON: 1 V or less
- Leakage current at OFF: 0.1 mA or less

Key scan input

- ON voltage: 1 V or less
- ON current: 3 mA or more
- OFF current: 1 mA or less

12. STANDARD SERIAL OUTPUT

12.1. Pin Assignment

SER.OUT

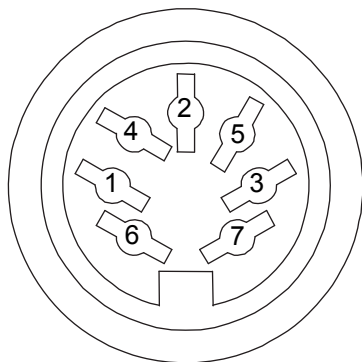

The applicable connector is a DIN connector 7-pin plug manufactured by Hosiden Corporation or the equivalent.

A TCP0576-715267 connector is provided with the indicator.

Pin No.	Description
1	NC
2	Frame ground
3	Current loop output No sign
4	NC
5	Current loop output No sign
6	NC
7	NC
Shell	Frame ground

12.2. Communication Specifications

Signal level	Current loop 0 to 20 mA
Baud rate (Si F-03)	600, 2400 bps
Character bit length	7 bits
Parity	Even
Star bit length	1 bit
Stop bit length	1 bit
Code	ASCII
Terminator	CR LF

12.3. Output Data

Select an output data (Si F-01) from the following:

- 1: Displayed weight value (default)
- 2: Gross value
- 3: Net value
- 4: Tare value
- 5: Gross value + Net value + Tare value
- 6: Total weight
- 7: Number of accumulations
- 8: Total weight and number of accumulations

12.4. Communication Type

Select a communication Type (Si F-02) from the following:

- 1: Interval output at the display update rate (FncF-03) (default)
- 2: In synchronization with automatic print
- 3: In synchronization with manual print
- 4: In synchronization with automatic/manual accumulation

12.5. Output Data Format

- Gross value, net value, tare value

Header 1	Header 2	Output weight value	Unit	Terminator
3 chars	3 chars	8 chars	2 chars	2 chars/1 char

Item	Value		
Header 1	<u>S</u> <u>T</u> <u>.</u>	Stable	
	<u>U</u> <u>S</u> <u>.</u>	Unstable	
	<u>O</u> <u>L</u> <u>.</u>	Overload	
Header 2 (Si F-01)	<u>G</u> <u>S</u> <u>.</u>	at CALF19=1	Gross value
	<u>N</u> <u>T</u> <u>.</u>		Net value
	<u>T</u> <u>R</u> <u>.</u>		Tare value
	<u>G</u> <u>S</u> <u>P</u> <u>.</u>	at CALF19=2	Gross value
	<u>N</u> <u>S</u> <u>P</u> <u>.</u>		Net value
	<u>T</u> <u>S</u> <u>P</u> <u>.</u>		Tare value
Output weight value (Si F-01)	<u>+</u> <u>0</u> <u>0</u> <u>1</u> <u>2</u> <u>.</u> <u>3</u> <u>4</u>	Figure with a sign	
	<u>+</u> <u>0</u> <u>0</u> <u>0</u> <u>0</u> <u>0</u> <u>0</u>	0	
	<u>+</u> <u>S</u> <u>P</u> <u>S</u> <u>P</u> <u>S</u> <u>P</u> <u>S</u> <u>P</u> <u>.</u> <u>S</u> <u>P</u> <u>S</u> <u>P</u>	Positive overload	
	<u>-</u> <u>S</u> <u>P</u> <u>S</u> <u>P</u> <u>S</u> <u>P</u> <u>S</u> <u>P</u> <u>.</u> <u>S</u> <u>P</u> <u>S</u> <u>P</u>	Negative overload	
Unit (CALF-01)	<u>S</u> <u>P</u> <u>S</u> <u>P</u>	None	
	<u>S</u> <u>P</u> <u>g</u>	g	
	<u>k</u> <u>g</u>	kg	
	<u>S</u> <u>P</u> <u>t</u>	t	
	No unit is added when the number of accumulations is output.		

SP: space

● Total weight, Number of accumulations

Header 2	Output weight value	Unit	Terminator
3 chars	11 chars	2 chars	2 chars/1 char

Item	Value	
Header 2 (Si F-01)	<u>I</u> <u>W</u> <u>.</u>	Total weight
	<u>I</u> <u>N</u> <u>.</u>	Number of accumulations
Output weight value (Si F-01)	<u>+</u> <u>0</u> <u>0</u> <u>0</u> <u>0</u> <u>0</u> <u>1</u> <u>2</u> <u>.</u> <u>3</u> <u>4</u>	Figure with a sign
	<u>+</u> <u>0</u> <u>0</u> <u>0</u> <u>0</u> <u>0</u> <u>0</u> <u>0</u> <u>0</u> <u>0</u>	0
	<u>+</u> <u>SP</u> <u>SP</u> <u>SP</u> <u>SP</u> <u>SP</u> <u>SP</u> <u>SP</u> <u>.</u> <u>SP</u> <u>SP</u>	Positive overload
	<u>-</u> <u>SP</u> <u>SP</u> <u>SP</u> <u>SP</u> <u>SP</u> <u>SP</u> <u>SP</u> <u>.</u> <u>SP</u> <u>SP</u>	Negative overload
Unit (CALF-01)	<u>SP</u> <u>SP</u>	None
	<u>SP</u> <u>g</u>	g
	<u>k</u> <u>g</u>	kg
	<u>SP</u> <u>t</u>	t
	No unit is added when the number of accumulations is output.	

SP: space

13. OPTION-01 BCD OUTPUT

13.1. Pin Assignment

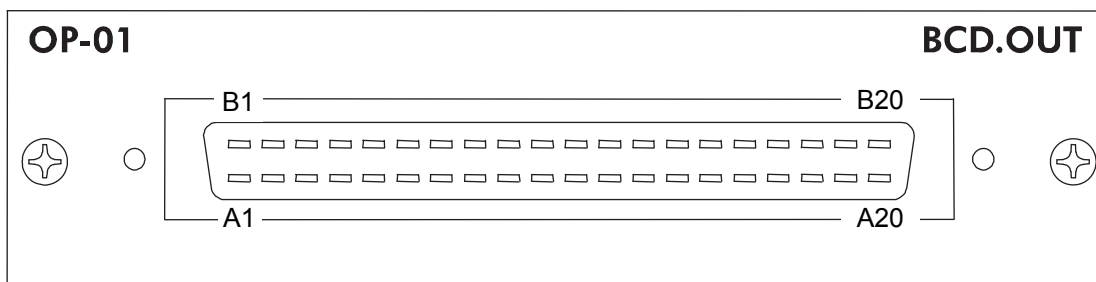

The applicable connector is an FCN-360 series 40-pin female connector manufactured by Fujitsu Component Limited or the equivalent.

An FCN-361J040 (connector) and an FCN-360C040 (cover) are provided with this option.

Pin No.	Description	Description	Pin No.
A1	1	2	B1
A2	4	8	B2
A3	10	20	B3
A4	40	80	B4
A5	100	200	B5
A6	400	800	B6
A7	1000	2000	B7
A8	4000	8000	B8
A9	10000	20000	B9
A10	40000	80000	B10
A11	100000	200000	B11
A12	400000	800000	B12
A13	OFF: Overload	ON: Positive OFF: Negative	B13
A14	ON: Stable	ON: Net value OFF: Gross or Tare value	B14
A15	Decimal point position		B15
A16	A15=ON, B15=ON, A16=ON, B16=ON: None		B16
	A15=OFF, B15=ON, A16=ON, B16=ON: 0.0		
	A15=ON, B15=OFF, A16=ON, B16=ON: 0.00		
	A15=ON, B15=ON, A16=OFF, B16=ON: 0.000		
	A15=ON, B15=ON, A16=ON, B16=OFF: 0.0000		
A17	Unit		B17
	A17=OFF, B17=OFF: None or kg		
	A17=ON, B17=ON: g		
	A17=OFF, B17=ON: t		
A17=ON, B17=OFF: lb (For USA only)			
A18	Strobe output	Hold input	B18
A19	Common	Common	B19
A20	Frame ground	Frame ground	B20

When the weight value is overloaded and the data output logic (bCdF-03) is set to negative logic (default), all of the output data is turned ON.

13.2. Connection Diagram

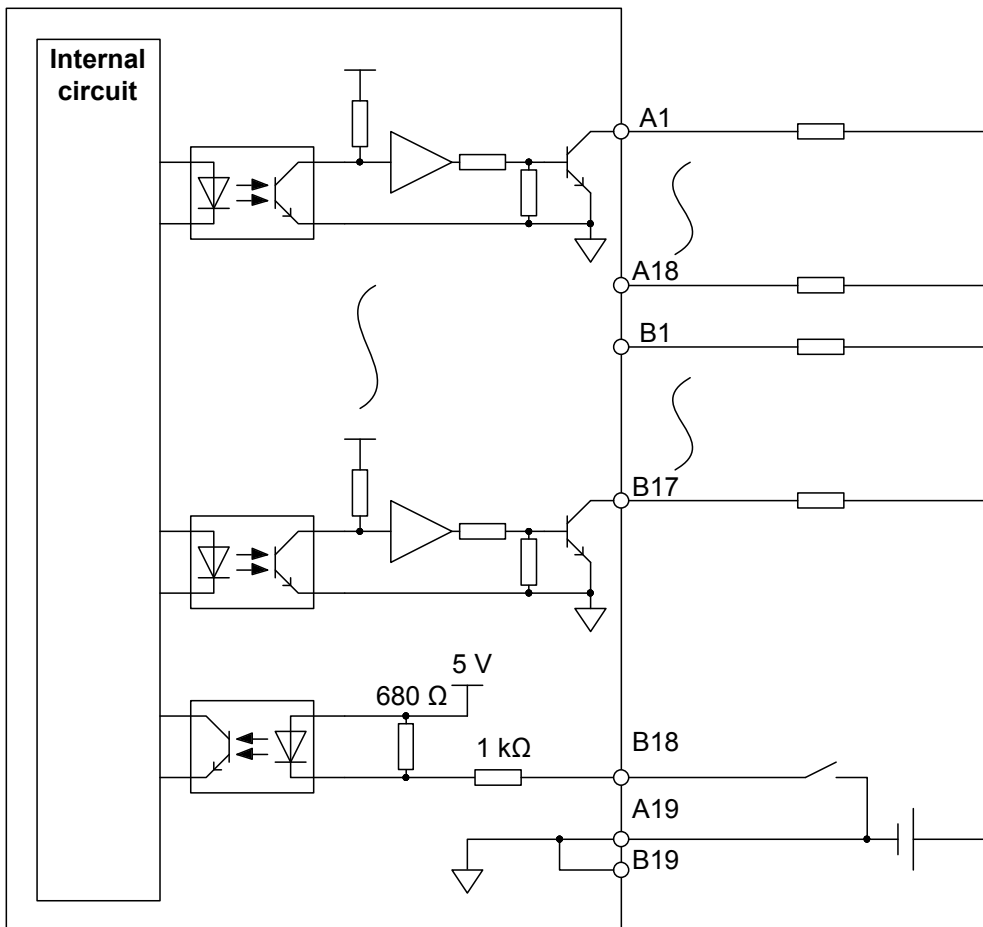

Data output, Strobe output

- Maximum load voltage: 30 VDC
- Maximum load current: 50 mA/point
- Voltage drop at ON: 1 V or less
- Leakage current at OFF: 0.1 mA or less

Hold input

- ON voltage: 1 V or less
- ON current: 3 mA or more
- OFF current: 1 mA or less

13.3. Data Output Timing

Select a data output timing (bCdF-02) from the following:

- 1: Interval output at the display update rate (FncF-03) (default)
- 2: In synchronization with automatic print
- 3: In synchronization with manual print

Timing chart

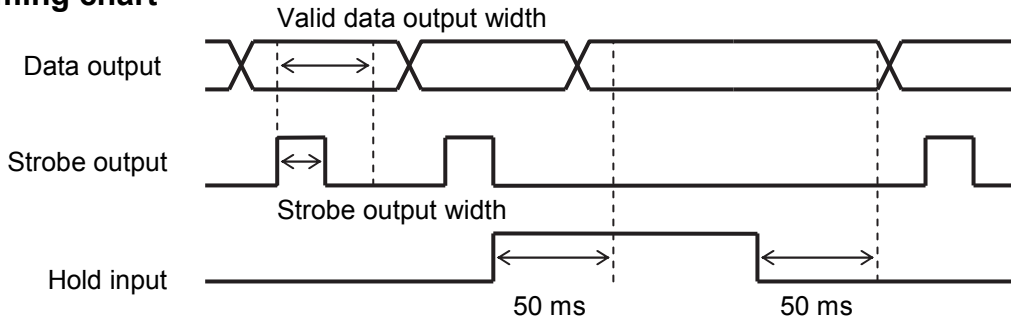

The valid data output width is twice the strobe output width. Read the data within the valid data output width. The strobe output width depends on the display update rate (FncF-03).

Display update rate Strobe output width

- 20 times/s 20 ms
- 10 times/s 45 ms
- 5 times/s 95 ms

Update will stop within 50 ms after the hold input turns ON. Then, update will restart within 50 ms after the hold input turns OFF.

13.4. Data Output Logic and Strobe Output Logic

Select a data output logic (bCdF-03) and a strobe output logic (bCdF-04) from the following:

- 1: Positive logic
- 2: Negative logic (default)

14. OPTION-03 RS-422/485

14.1. Terminal Assignment

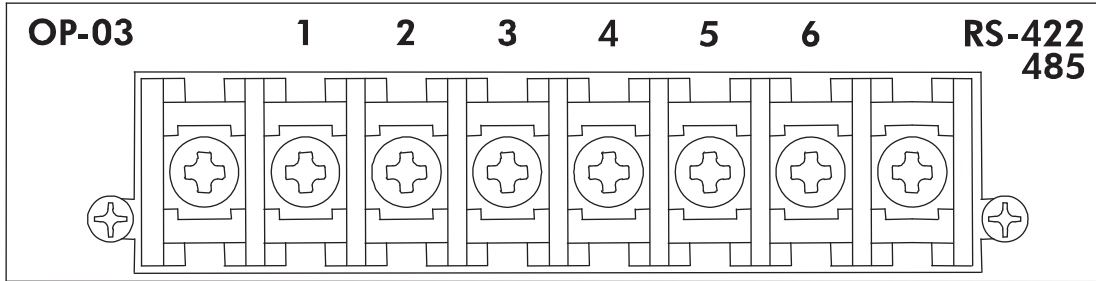

Terminal No.	Description
1	Send data +
2	Send data -
3	Receive data +
4	Receive data -
5	Open-circuit: Disable the terminal resistor Short-circuited to No. 4 Enable the terminal resistor
6	Signal ground

14.2. Connection Diagram

14.2.1. RS-422

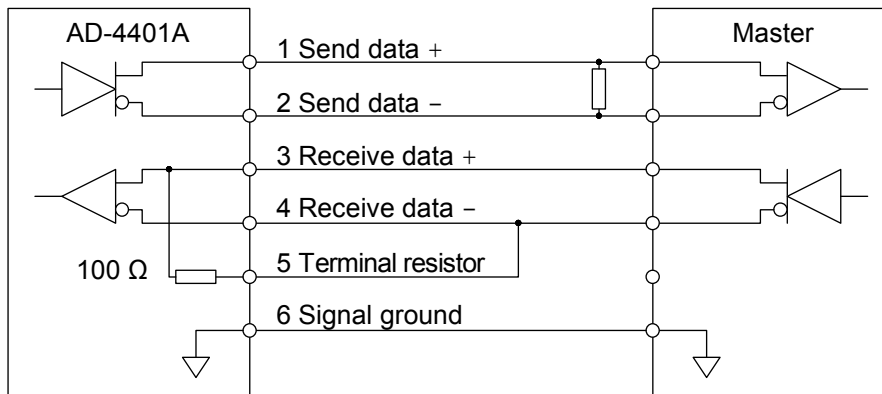

14.2.2. 2-wire RS-485

Short-circuit the terminals No.1 and No.3, and the terminals No.2 and No.4 as shown below.

Terminal resistors must be installed on both ends of the circuit.

When a multidrop connection is required, refer to “Multidrop connection” in “14.9. Format When Communication Type (rS F-02) is 4”.

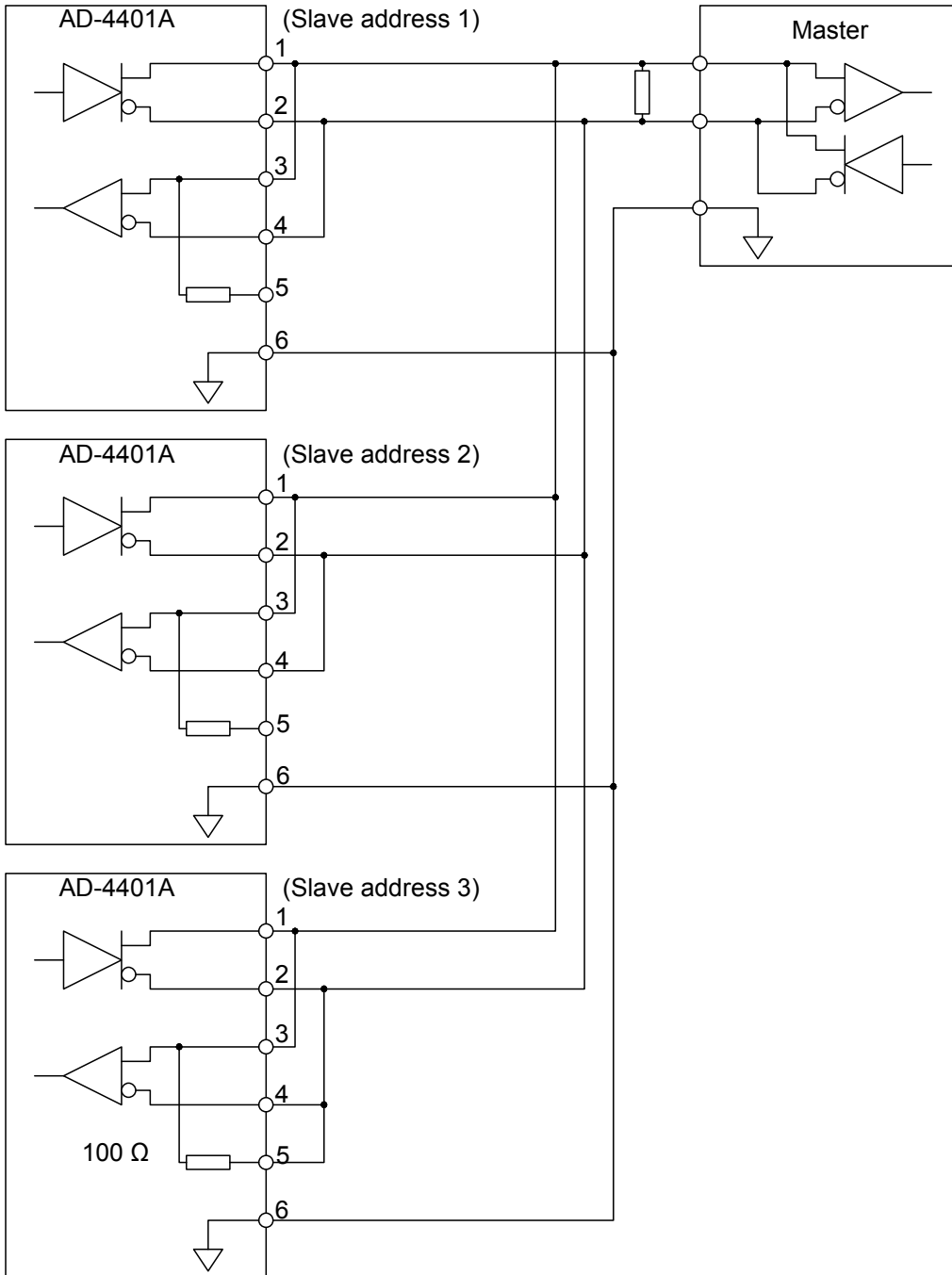

14.3. Communication Specifications

Signal level (rS F-08, rS F-09)	RS-422/RS-485 compliant
Baud rate (rS F-03)	600, 1200, 2400, 4800, 9600, 19200, 38400, 115200 bps
Character bit length (rS F-05)	7, 8 bits
Parity (rS F-04)	None, Odd, Even
Start bit length	1 bit
Stop bit length (rS F-06)	1, 2 bits
Code	ASCII, Binary (for Modbus-RTU)
Terminator (rS F-07)	CR LF, CR

14.4. Output Data

Select an output data (rS F-01) from the following:

- 1: Displayed weight value (default)
- 2: Gross value
- 3: Net value
- 4: Tare value
- 5: Gross value + Net value + Tare value
- 6: Total weight
- 7: Number of accumulations
- 8: Total weight and number of accumulations

14.5. Communication Type

Select a communication type (rS F-02) from the following:

- 1: Interval output at the display update rate (FncF-03) (default)
- 2: In synchronization with automatic print
- 3: In synchronization with manual print
- 4: Write data or read setpoint values by commands from the master
- 5: Interval output of comparison result and gross value at 100 times/s.
- 6: Interval output of comparison result and net value at 100 times/s.
- 7: In synchronization with automatic/manual accumulation
- 8: Interval output at 100 times/s
- 9: Modbus-RTU (available for the software version 1.03 or later)

14.6. Format When Communication Type (rS F-02) is 1, 2, 3 or 7

●Data format (Gross value, Net value, Tare value)

Header 1	Header 2	Output weight value	Unit	Terminator
3 chars	3 chars	8 chars	2 chars	2 chars/1 char

Item	Value		
Header 1	<u>S</u> <u>T</u> <u>.</u>	Stable	
	<u>U</u> <u>S</u> <u>.</u>	Unstable	
	<u>O</u> <u>L</u> <u>.</u>	Overload	
Header 2 (Si F-01)	<u>G</u> <u>S</u> <u>.</u>	at CALF19=1	Gross value
	<u>N</u> <u>T</u> <u>.</u>		Net value
	<u>T</u> <u>R</u> <u>.</u>		Tare value
	<u>G</u> <u>S</u> <u>P</u> <u>.</u>	at CALF19=2	Gross value
	<u>N</u> <u>S</u> <u>P</u> <u>.</u>		Net value
	<u>T</u> <u>S</u> <u>P</u> <u>.</u>		Tare value
Output weight value (Si F-01)	<u>+</u> <u>0</u> <u>0</u> <u>1</u> <u>2</u> <u>.</u> <u>3</u> <u>4</u>	Figure with a sign	
	<u>+</u> <u>0</u> <u>0</u> <u>0</u> <u>0</u> <u>0</u> <u>0</u>	0	
	<u>+</u> <u>S</u> <u>P</u> <u>S</u> <u>P</u> <u>S</u> <u>P</u> <u>.</u> <u>S</u> <u>P</u> <u>S</u> <u>P</u>	Positive overload	
	<u>-</u> <u>S</u> <u>P</u> <u>S</u> <u>P</u> <u>S</u> <u>P</u> <u>.</u> <u>S</u> <u>P</u> <u>S</u> <u>P</u>	Negative overload	
Unit (CALF-01)	<u>S</u> <u>P</u> <u>S</u> <u>P</u>	None	
	<u>S</u> <u>P</u> <u>g</u>	g	
	<u>k</u> <u>g</u>	kg	
	<u>S</u> <u>P</u> <u>t</u>	t	
	No unit is added when the number of accumulations is output.		

SP: space

●Data format (Total weight, Number of accumulations)

Header 2	Output weight value	Unit	Terminator
3 chars	11 chars	2 chars	2 chars/1 char

Item	Value	
Header 2 (Si F-01)	<u>T</u> <u>W</u> <u>.</u>	Total weight
	<u>T</u> <u>N</u> <u>.</u>	Number of accumulations
Output weight value (Si F-01)	<u>+</u> <u>0</u> <u>0</u> <u>0</u> <u>0</u> <u>0</u> <u>1</u> <u>2</u> <u>.</u> <u>3</u> <u>4</u>	Figure with a sign
	<u>+</u> <u>0</u> <u>0</u> <u>0</u> <u>0</u> <u>0</u> <u>0</u> <u>0</u> <u>0</u> <u>0</u>	0
	<u>+</u> <u>SP</u> <u>SP</u> <u>SP</u> <u>SP</u> <u>SP</u> <u>SP</u> <u>SP</u> <u>.</u> <u>SP</u> <u>SP</u>	Positive overload
	<u>-</u> <u>SP</u> <u>SP</u> <u>SP</u> <u>SP</u> <u>SP</u> <u>SP</u> <u>SP</u> <u>.</u> <u>SP</u> <u>SP</u>	Negative overload
Unit (CALF-01)	<u>SP</u> <u>SP</u>	None
	<u>SP</u> <u>g</u>	g
	<u>k</u> <u>g</u>	kg
	<u>SP</u> <u>t</u>	t
	No unit is added when the number of accumulations is output.	

SP: space

14.7. Format When Communication Type (rS F-02) is 5 or 6

- Data format (Comparison result + Weight value)

Comparison result	Gross value/Net value/ Output weight value	Terminator
2 chars	6 chars	2 chars/1 char

Item	Value	
Comparison result	F F	*1
Gross value (rS F-02=5) Net value (rS F-02=6) Output weight value (rS F-01)	0 0 0 0 7 F	*2

- *1: Comparison results are converted from 8 binary digits into 2 hexadecimal digits.

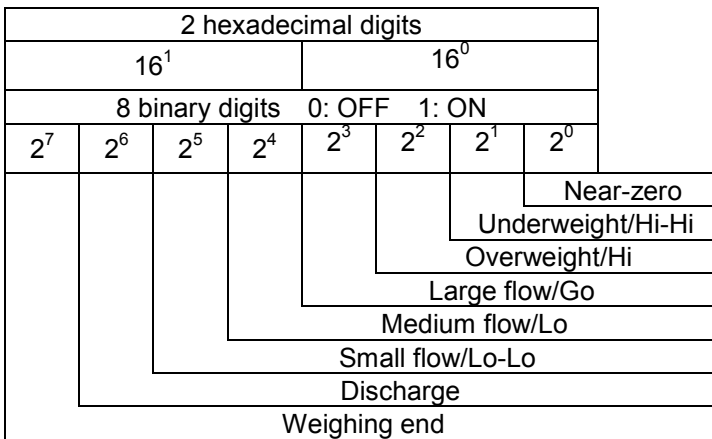

- *2: The gross value and the net value are converted from a signed decimal number into a 6-digit hexadecimal number. Negative numbers are represented by the two's complement. A decimal point is not included.

Decimal	Hexadecimal
...	...
+127	00007F
...	...
2	000002
1	000001
0	000000
-1	FFFFFF
-2	FFFFFE
...	...
-127	FFFF81
...	...

14.8. Format When Communication Type (rS F-02) is 8

●Data format (Weight value)

Slave address	Output weight value	Terminator
3 chars	8 chars	2 chars/1 char

Item	Value	
Output weight value (rS F-01)	+ <u>0</u> <u>0</u> <u>0</u> <u>1</u> <u>2</u> <u>3</u> <u>4</u>	Figure with a sign
	+ <u>0</u> <u>0</u> <u>0</u> <u>0</u> <u>0</u> <u>0</u>	0
	+ <u>SP</u> <u>SP</u> <u>SP</u> <u>SP</u> <u>.</u> <u>SP</u> <u>SP</u>	Positive overload
	- <u>SP</u> <u>SP</u> <u>SP</u> <u>SP</u> <u>.</u> <u>SP</u> <u>SP</u>	Negative overload

A decimal point is not added to the output weight value.

14.9. Format When Communication Type (rS F-02) is 4

●Data format (Command)

Slave address	Command	Terminator
2 chars	2 chars	2 chars / 1char

Item	Value	
Command	<u>R</u> <u>W</u>	Read weight data
	<u>R</u> <u>B</u>	Read comparison result + gross value Read comparison result + net value
	<u>R</u> <u>E</u>	Read net value at weighing end
	<u>R</u> <u>T</u>	Read total weight + number of accumulations
	<u>R</u> <u>S</u>	Read setpoint values
	<u>M</u> <u>Z</u>	Zero setting
	<u>M</u> <u>I</u>	Tare
	<u>C</u> <u>I</u>	Tare clear
	<u>D</u> <u>I</u>	Total clear
	<u>M</u> <u>G</u>	Display gross value in the main display
	<u>M</u> <u>N</u>	Display net value in the main display
	<u>B</u> <u>B</u>	Weighing start
	<u>B</u> <u>D</u>	Discharge start
	<u>H</u> <u>B</u>	Emergency stop
<u>S</u> <u>S</u>	Write setpoint values	

●Weight data format

Data format is the same as that when communication type (rS F-02) is 1, 2, 3 or 7.

Refer to “14.5. Format When Communication Type (rS F-02) is 1, 2, 3 or 7” for the weight data format.

●Data format (Setpoint values)

Setpoint data format depends on the weighing mode (CALF-14).

Normal batching / Simple comparison normal batching: (CALF-14 1, 3)

Final weight	Free fall	Preliminary	Optional preliminary	Overweight	Underweight	Near-zero	Terminator
6 chars	6 chars	6 chars	6 chars	6 chars	6 chars	6 chars	2 chars /1char

Loss-in-weight batching / Simple comparison loss-in-weight batching: (CALF-14 2, 4)

Final weight	Free fall	Preliminary	Full	Overweight	Underweight	Near-zero	Terminator
6 chars	6 chars	6 chars	6 chars	6 chars	6 chars	6 chars	2 chars /1char

Check weighing 1/2/3/4: (CALF-14 5, 6, 7, 8)

Target weight	Hi-Hi limit	Hi limit	Lo limit	Lo-Lo limit	-	Near-zero	Terminator
6 chars	6 chars	6 chars	6 chars	6 chars	6 chars	6 chars	2 chars /1char

Item	Value (e.g. Unit = kg, Decimal point position = 0.000)	
Final weight/Target	<u>0 2 0 0 0 0</u>	20.000 kg
Free fall/Hi-Hi limit	<u>0 0 0 1 0 0</u>	0.100 kg
Preliminary/Hi limit	<u>0 0 2 0 0 0</u>	0.200 kg
Optional preliminary/Full/Lo limit	<u>0 1 8 0 0 0</u>	18.000 kg
Overweight/Lo-Lo limit	<u>0 0 0 0 2 0</u>	0.020 kg
Underweight	<u>0 0 0 0 2 0</u>	0.020 kg
Near-zero	<u>0 0 0 2 0 0</u>	0.200 kg

●Multidrop connection

When a master and some AD-4401As are connected by a 1:n multidrop connection, a different slave address (rS F-09) is assigned to each AD-4401A. When the master sends a command by adding the slave address (@ 0 1 to @ 9 9) at the beginning, the AD-4401A with the matching slave address sends a response by adding the slave address (@ 0 1 to @ 9 9) at the beginning.

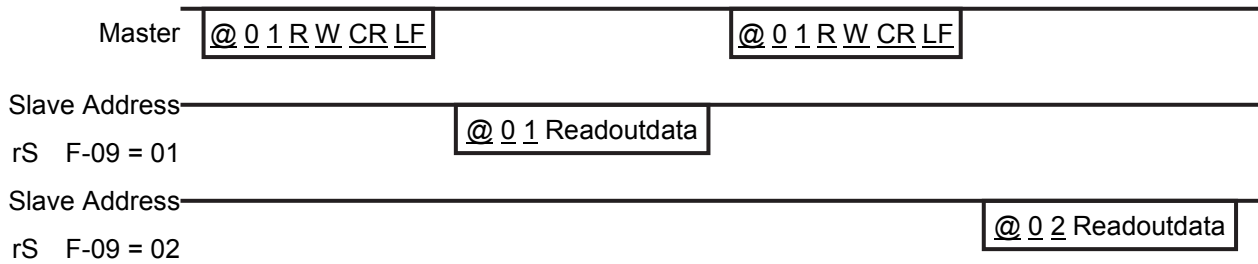

●Communication diagram

Three communication diagrams are shown below.

Reading data

R W: Read weight data

R B: Read comparison result + gross value, Read comparison result + net value

R E: Read net value at weighing end

R T: Read total weight + number of accumulations

R S: Read setpoint values

When the command above is sent, the corresponding data is sent in response.

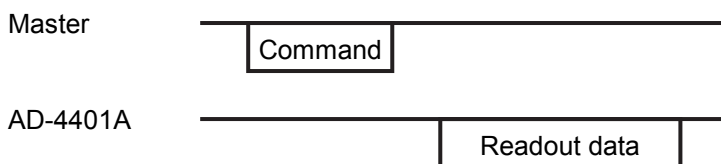

Function commands

M Z : Zero setting

M T : Tare

C T : Tare clear

D T : Total clear

M G : Display gross value in the main display

M N : Display net value in the main display

B B : Weighing start

B D : Discharge start

H B : Emergency stop

When the command above is sent, the command is echoed back and is executed.

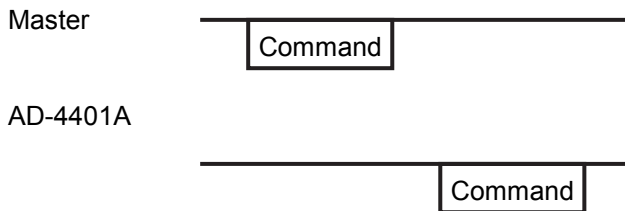

Writing setpoint values

When writing setpoint values, set the setpoint setting method (SP F-01) to 0 (Setpoint input not used).

S S : Write setpoint values

When the command above is sent, the command is echoed back.

Then, when setpoint data is sent, the data is echoed back and saved.

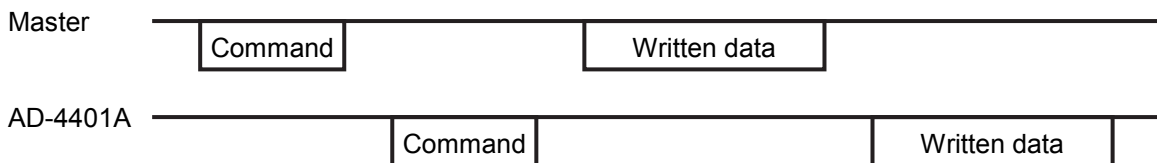

Error response

I E : Response to the mode that does not accept commands

V E : Response to data whose format is correct but whose value is out of range

? E : Response to illegal commands/formats

14.10. Modbus-RTU When Communication Type (rS F-02) is 9

Modbus-RTU is available for the software version 1.03 or later.

When the communication type (rS F-02) is set to 9: Modbus-RTU, communication settings are as the following.

Parity	Even
Character bit length	8 bits
Stop bit length	1 bit
RS-422/485 electrical specifications	2-wire RS-485

For the 2-wire RS-485 connection method, refer to the connection diagram in "14.2.2. 2-wire RS-485".

Select a baud rate and a slave address from the following:

rS F-	Item	Setting value	Default
03	Baud rate	5: 9600 bps 6: 19200 bps 7: 38400 bps 8: 115200 bps	5
09	RS-422/485 slave address	1 to 99	0

Function code and maximum quantity

Code	Function name	Maximum quantity
01	Read coils	100
03	Read holding registers	100
05	Write single coil	1
06	Write single register	1
15	Write multiple coils	1
16	Write multiple registers	100

●Data address

Data address	R/W	Item	Data address	R/W	Item
000001	R	Near-zero	000201	W *1	Zero setting
000002		Underweight	000202		Tare
000003		Overweight	000203		Weighing start
000004		OK	000204		Emergency stop
000005		Large flow	000205		Discharge start
000006		Medium flow	000206		Manual free fall correction
000007		Small flow	000207		Tare clear
000008		Discharge	000208		Accumulation
000009		Weighing end	000209		Undoing accumulation
000010		Full	000210		Total clear
000011		Hi-Hi	000211		Print
000012		Hi	000212		Zero clear
000013		Go	000213		Display Gross
000014		Lo	000214		Display Net
000015		Lo-Lo	000215		Pause
000016		Stable	000216		Weighing restart
000017		Gross (0)/Net (1) display	000217		Forced weighing end
000018		In weighing sequence	000218		Forced discharge end
000019		Weighing sequence error	000219		Error clear
000020		Overload	000220		Manual correction flow
000021	When zero setting fails	000221-000300	Reserved internally		
000022	When tare fails				
000023	Total weight overflow				
000024	Number of accumulations overflow				
000025-000100	Reserved internally				
000101-000200	Reserved internally	000301-000400	R/W	Reserved internally	
		000401	W *1	Zero calibration	
		000402		Span calibration*2	
		000403-000500		Reserved internally	

*1: When "1" is written, the operation is executed.

*2: Before span calibration, set CALF-23 Calibration weights at span calibration via Modbus (400145-400146).

Data address (*1)	R/W	Item	
400001-400002	R	Displayed weight value	
400003-400004		Gross value	
400005-400006		Net value	
400007-400008		Tare value	
400009-400010		Status display (*2)	
400011-400012		Sub-display	
400013-400014		Total weight	
400015-400016		Number of accumulations	
400017-400018		Gross value at weighing end	
400019-400020		Net value at weighing end	
400021-400022		Tare value at weighing end	
400023-400024		Sequence number	
400025-400026		Sequence error number	
400027-400096		Reserved internally	
400095-400096		Voltage ratio (nV/V) (*3)	
400097-400098		Access interval timer (ms)	
400099-400100			During an internal write cycle / Write result (*4)
400101-400146		R/W	Calibration functions (*5)
400147-400200	Reserved internally		
400201-400202	R/W	Setpoint Final weight	
400203-400204		Setpoint Free fall	
400205-400206		Setpoint Preliminary	
400207-400208		Setpoint Optional preliminary	
400209-400210		Setpoint Overweight	
400211-400212		Setpoint Underweight	
400213-400214		Setpoint Full	
400215-400216		Setpoint Near-zero	
400217-400218		Setpoint Go	
400219-400220		Setpoint Hi	
400221-400222		Setpoint Lo	
400223-400224		Setpoint Hi-Hi	
400225-400226		Setpoint Lo-Lo	
400227-400300		Reserved internally	
400301-400400	R/W	Basic functions (*5)	
400401-400500		Sequence functions (*5)	
400501-400600		Control input functions (*5)	
400601-400700		Control output functions (*5)	
400701-400800		Standard serial output functions (*5)	
400801-400900		BCD output functions (*5)	
400901-401000		RS-422/485, RS-232C functions (*5)	
401001-401100		Setpoint input functions (*5)	
401101-401200		Analog 4-20 mA output functions (*5)	
401201-401400		Reserved internally	

*1: "Double Word" word order is low word first (L/H).

*2, *4: For the detailed description, refer to the next page.

*3: This function is available for the software version 1.08 or later

*5: Refer to "20. FUNCTION LIST".

***2: Status display bit address**

Data address	Item
400009.15-07	Reserved internally
400009.06	Near-zero (Check weighing)
400009.05	Small flow (Normal / Loss-in-weight) Lo-Lo (Check weighing)
400009.04	Medium flow (Normal / Loss-in-weight) Lo (Check weighing)
400009.03	Large flow / Full (Normal / Loss-in-weight) Go (Check weighing)
400009.02	Overweight (Normal / Loss-in-weight) Hi (Check weighing)
400009.01	Underweight (Normal / Loss-in-weight) Hi-Hi (Check weighing)
400009.00	Near-zero (Normal / Loss-in-weight)
400010.15-07	Reserved internally
400010.06	ZERO
400010.05	STABLE (MD: Motion detection)
400010.04	GROSS
400010.03	NET
400010.02	HOLD
400010.01	Function <input type="checkbox"/> (FncF-05)
400010.00	ALARM

***3: During an internal write cycle / Write result**

- 0: Write success
- 1: Write failure
- 2-8: Calibration error (C Err) Refer to "6.2. Calibration Using Calibration Weights".
- 15: During an internal write cycle

15. OPTION-04 RS-232C

15.1. Pin Assignment

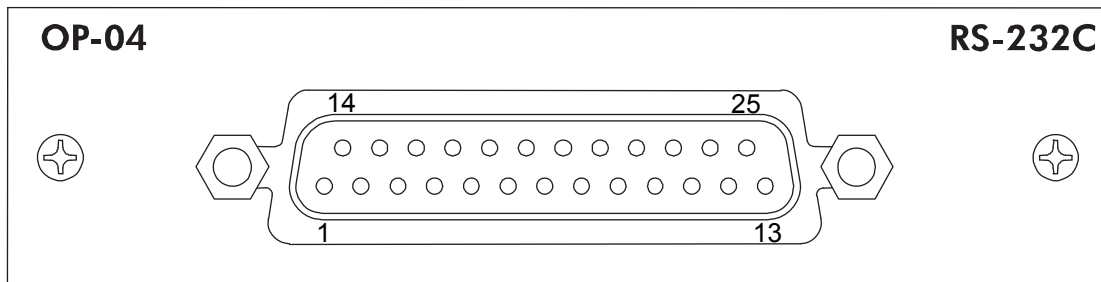

The applicable connector is a D-sub 25-pin male connector. The locking screw is M2.6.

The connector is not provided and must be prepared by the user.

Pin No.	Description
1	FG
2	RXD
3	TXD
4	CTS
5	RTS
6	DTR
7	GND
8	DCD
9 to 19	NC
20	DSR
21 to 25	NC

15.2. Connection Diagram

Connection to a PC serial port is as follows.

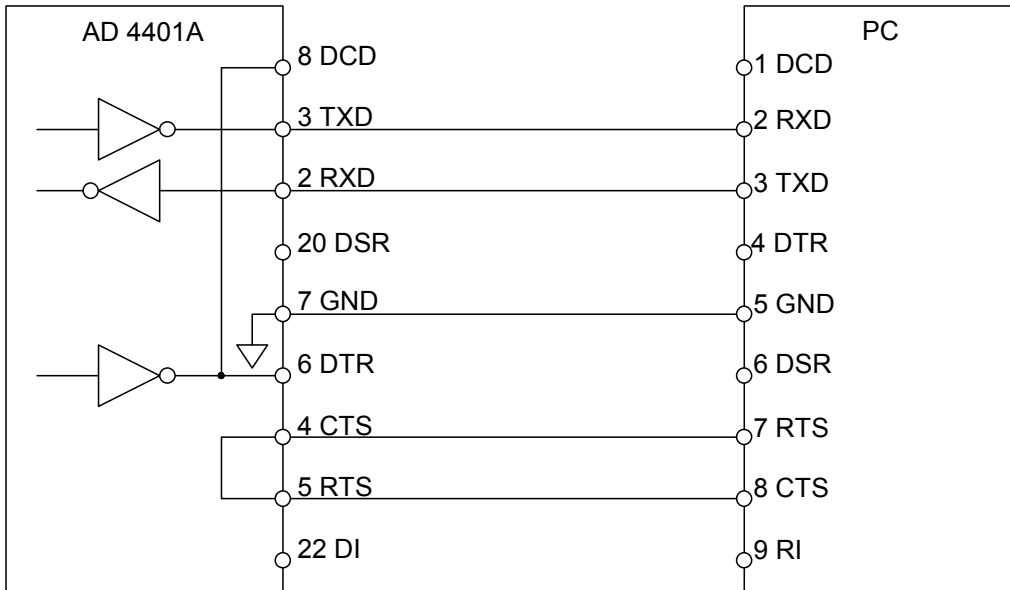

15.3. Communication Specifications

Signal Level	RS-232 compliant
Baud rate (rS F-03)	600, 1200, 2400, 4800, 9600, 19200, 38400, 115200 bps
Character bit length (rS F-05)	7, 8 bits
Parity (rS F-04)	None, Odd, Even
Start bit length	1 bit
Stop bit length (rS F-06)	1, 2 bits
Code	ASCII
Terminator (rS F-07)	CR LF, CR

15.4. Output Data, Communication Type

Refer to “14. RS-422/485” for output data and communication type.

16. OPTION-07 ANALOG 4-20 mA OUTPUT

16.1. Terminal Assignment

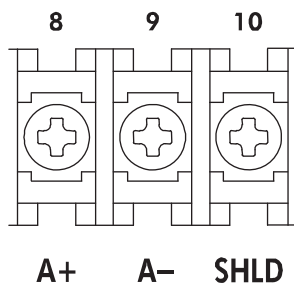

Terminal No.	Symbol	Description
8	A+	Analog current output +
9	A-	Analog current output -
10	SHLD	Frame ground

When the optional analog 4-20 mA output is not installed, the pins No.8 and No.9 are vacant. Check the 07 column of the option list on the side of the indicator casing.

16.2. Connection Diagram

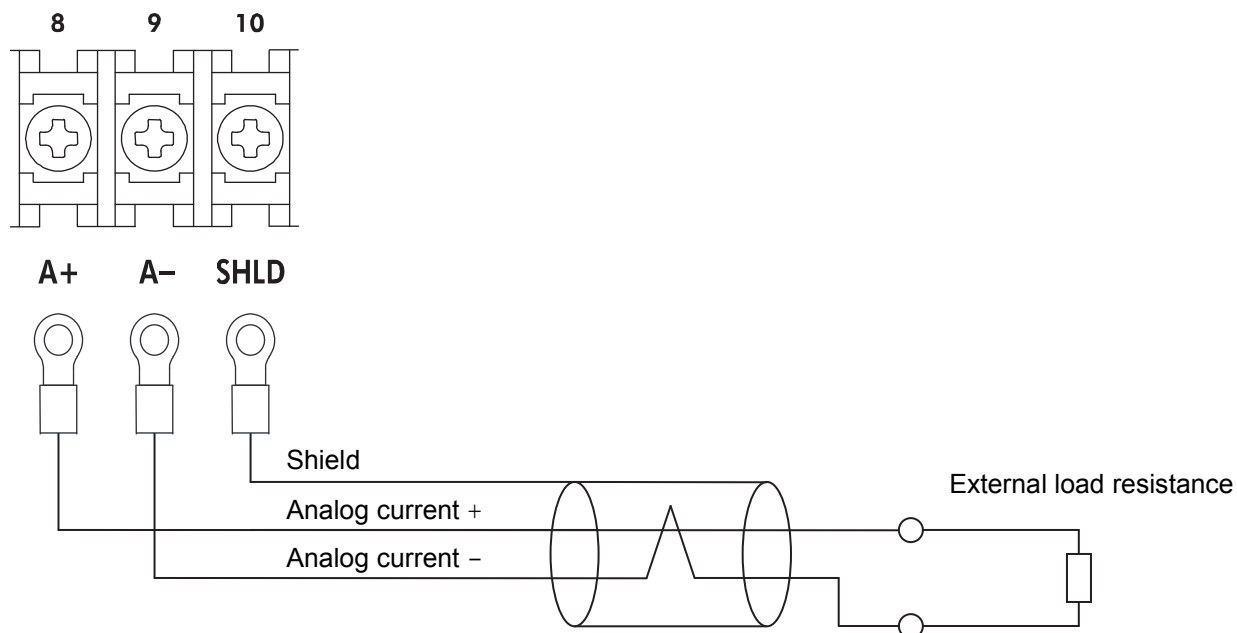

Applicable solderless terminal: R1.25-3

Applicable wire size: 0.3 to 0.75 mm². Use a 2-wire shielded twisted pair cable.

External load resistance: 0 to 600 Ω

16.3. Output Specifications

Analog current output	4 to 20 mA DC External load resistance: 0 to 600 Ω
Maximum resolution	1/4000
Accuracy	$\pm 0.1\%$ FS
Temperature coefficient	Offset drift: $\pm 3.2\mu\text{A}/^\circ\text{C}$ Gain drift: $\pm 0.02\%/^\circ\text{C}$
Conversion rate	10 ms

16.4. Output Functions

Select an output weight value (An F-01) from the following:.

- 1: Displayed weight value (default)
- 2: Gross value
- 3: Net value

● Output adjustment

Output characteristic is represented by the straight line obtained by connecting between the weight value at 4 mA output (An F-02) and the weight value at 20 mA output (An F-03).

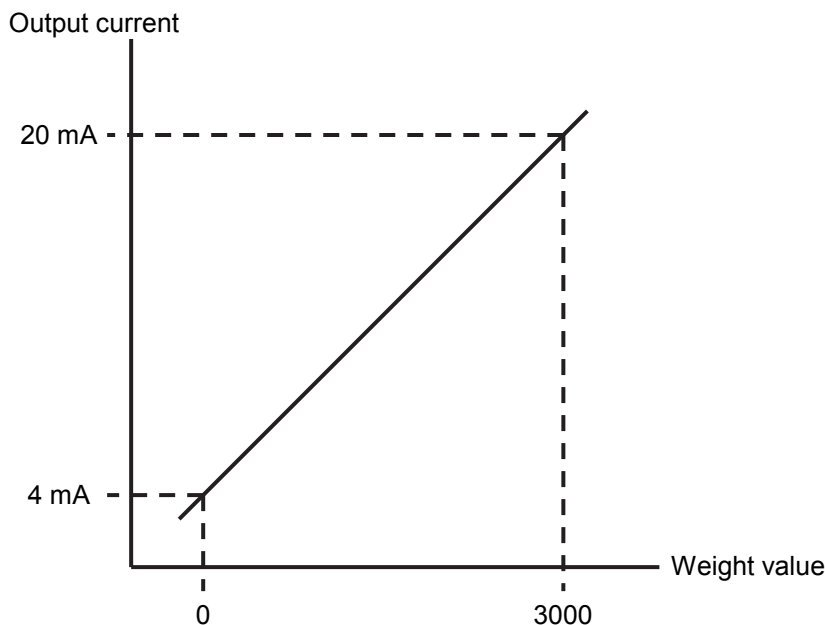

17. SETPOINT SETTING

Set setpoint values for batch weighing and check weighing.

Select a setpoint setting method (SP F-01) from the following.

- 0: Key switches, RS-232C or RS-422/485 (Setpoint input not used) (default)
- 1:- 5-digit input from external devices
- 2:- 16-digit input from external devices

Refer to “14. RS-422/485” for the setting procedure of the RS-232C or RS-422/485.

Refer to “11. SETPOINT INPUT” for the setting procedure using 5-digit or 16 digit input from external devices.

17.1. Setting Using Key Switches

Operation

Normal mode	
SETPOINT key	Goes to the item selection mode.
Item selection	
ENTER key	Selects the blinking item in the lower status display and goes to the inputting mode of the item.
TARE key	Shifts the blinking item in the lower status display to the right.
ZERO key	Shifts the blinking item in the lower status display to the left.
ON/OFF key	Returns to the normal mode.
Setpoint input	
ENTER key	Saves the setpoint and returns to the item selection mode.
TARE key	Shifts the blinking digit to the right.
ZERO key	Shifts the blinking digit to the left.
NET/GROSS key	Increases the blinking digit by one.
Function key	Decreases the blinking digit by one.
ON/OFF key	Cancels the setpoint and returns to the item selection mode.

Normal mode

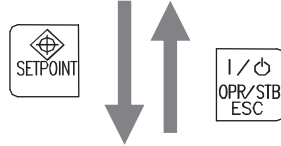
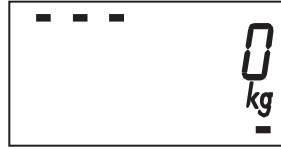

Select an item

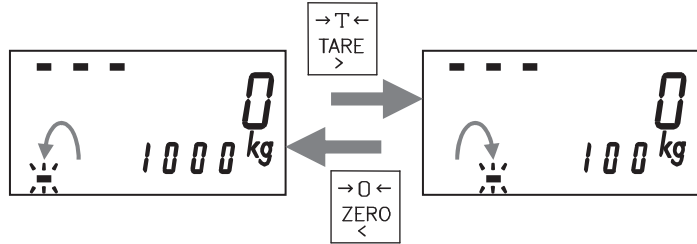

Input a setting value

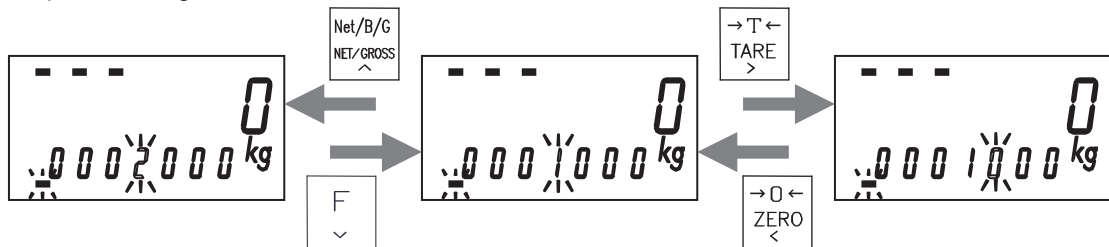

17.2. Setpoint Values List

Setpoints available for setting depend on the calibration function weighing mode (CALF-14).

When the minimum division (CALF-03) is 10 d or more, the setpoint will be ten times the setting value.

Weighing mode: Normal batching / Simple comparison normal batching

Status display	Item	Setting value
Blinking FINAL	Final weight	-999999 to 9999999
Blinking F.FALL	Free fall	
Blinking PRELIM	Preliminary	-999999 to 9999999
Blinking OP.PLM	Optional preliminary	0: Not used
Blinking OVER	Overweight	-999999 to 9999999
Blinking UNDER	Underweight	
Blinking Z.BAND	Near-zero	

Weighing mode: Loss-in-weight batching / Simple comparison loss-in-weight batching

Attach the accessory status label on the lower status display.

Status display	Item	Setting value
Blinking FINAL	Final weight	-999999 to 9999999
Blinking F.FALL	Free fall	
Blinking PRELIM	Preliminary	-999999 to 9999999
Blinking FULL	Full	0: Not used
Blinking OVER	Overweight	-999999 to 9999999
Blinking UNDER	Underweight	
Blinking Z.BAND	Near-zero	

Weighing mode: Check weighing 1/2/3/4

Attach the accessory status label on the lower status display.

Status display	Item	Setting value
Blinking Z.BAND	Near-zero	-999999 to 9999999
Blinking Lo-Lo	Lo-Lo	
Blinking Lo	Lo	
Blinking Go	Go	
Blinking Hi	Hi	
Blinking Hi-Hi	Hi-Hi	

18. OPERATION CHECKING

Operations are checked in the checking mode.

Select an operation to be checked and press the ENTER key.

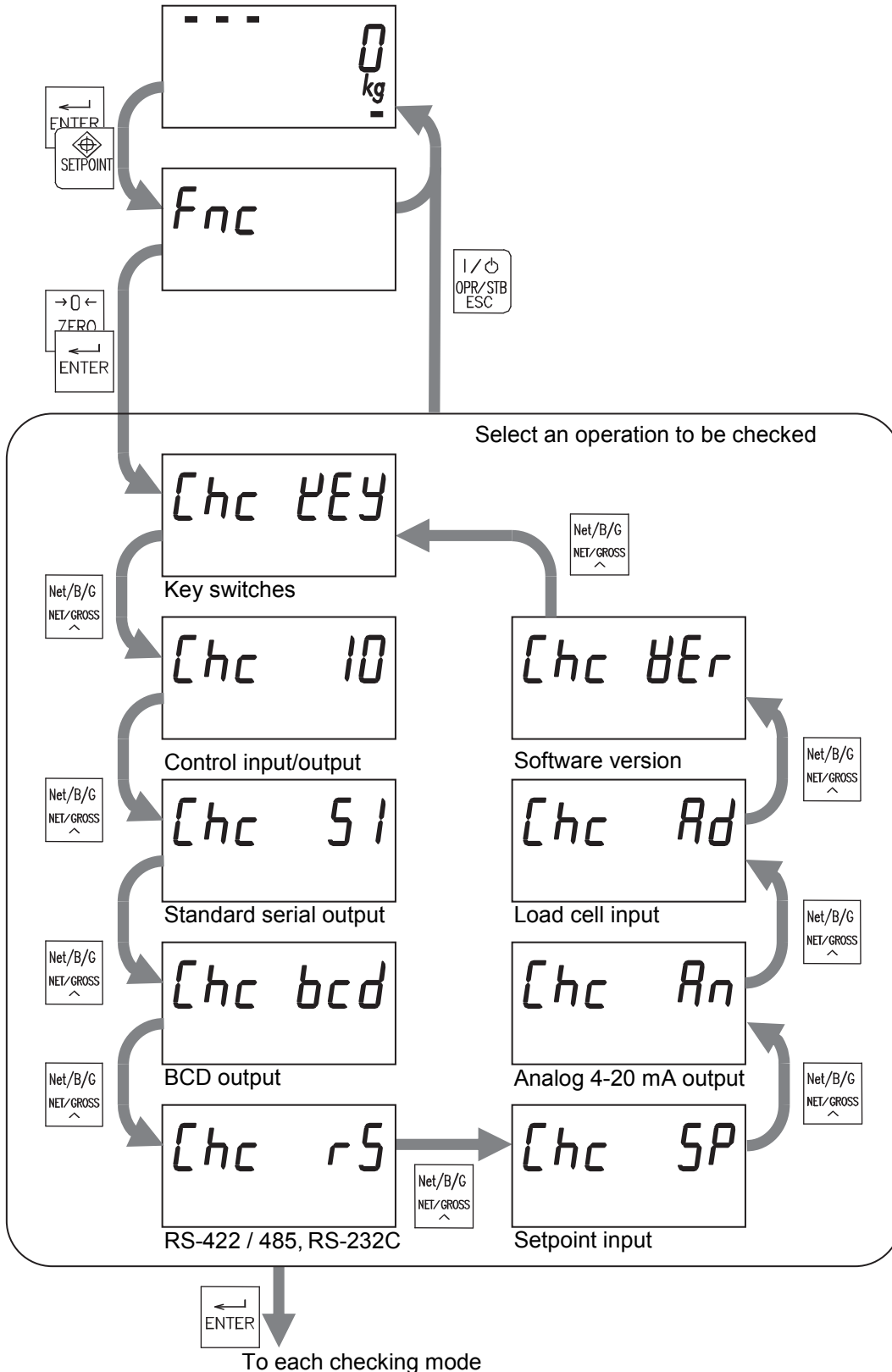

18.1. Checking Key Switches

When a key switch is pressed, "0" in the corresponding position turns to "1".

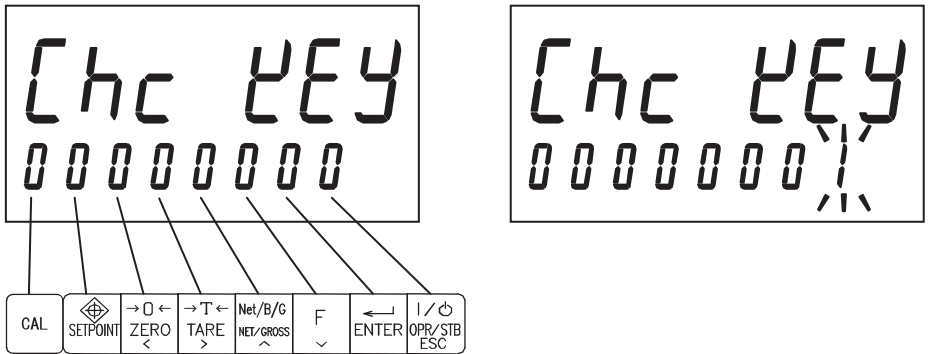

18.2. Checking Control Input/Output

When an input terminal is ON, "0" in the corresponding position turns to "1".

When the NET/GROSS key or Function key is pressed, the corresponding pin No. of the control output B1 to B6 turns ON.

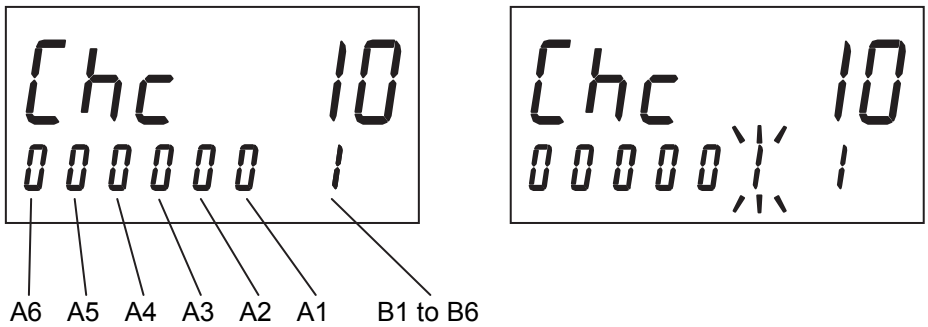

18.3. Checking Standard Serial Output

When the ENTER key is pressed, "123" is sent. The communication specifications comply with the standard serial output specifications.



18.4. Checking BCD Output

When the hold input turns ON, "0" turns to "1" and the output of the displayed pin No. turns ON.
Press the NET/GROSS key or Function key to switch pin Nos.

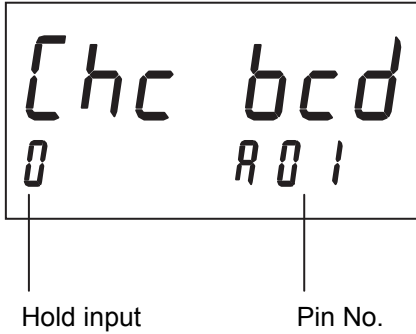

18.5. Checking RS-422/485, RS-232C

When the ENTER key is pressed, "123" is sent. When "123" is received, "PASS" is displayed.
The communication specifications comply with the RS-422/485, RS-232C specifications.



18.6. Checking Setpoint Input

The output terminal in the sub-display turns ON and the read value is displayed.

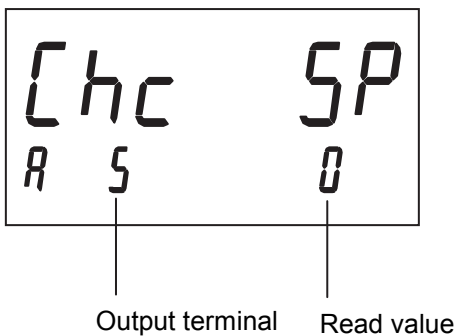

18.7. Checking Analog 4-20 mA Output

The current value (mA) in the sub-display is output.

Press the NET/GROSS key or Function key to increase or decrease the current value.



2 mA Output

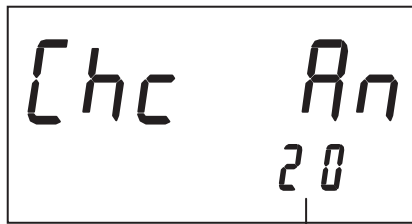

20 mA Output

18.8. Checking Load Cell Input

The load cell signal voltage (mV/V) is displayed in the sub-display.



18.9. Checking Software Version

The AD-4401A software version is displayed in the sub-display.



18.10. Checking the Load Cell Connection with a Digital Multimeter

The load cell connection can be checked easily using a digital multimeter.

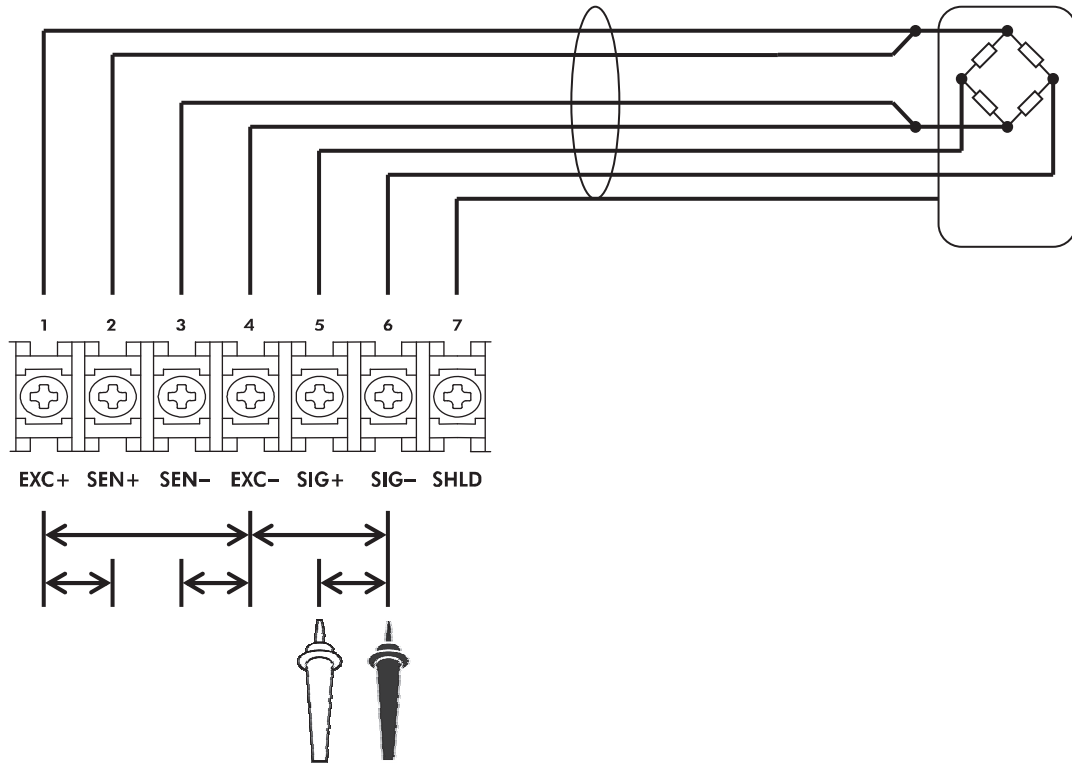

Measurement point		Item to be measured	Judging
1 EXC+	4 EXC-	Load cell excitation voltage	Normally 9 to 10 V.
5 SIG+	6 SIG-	Load cell output voltage	Normally 0 to 30 mV.
1 EXC+	2 SEN+	EXC+ voltage drop by load cell cable	Normally 0.2 V or less. The value may exceed 2 V when a long cable is used. For the 4-wire connection, it is 0 V.
4 EXC-	3 SEN-	EXC- voltage drop by load cell cable	Normally 0.2 V or less. The value may exceed 2 V when a long cable is used. For the 4-wire connection, it is 0 V.
6 SIG-	4 EXC-	Load cell middle point voltage	Normally 4.5 to 5 V, half of the load cell excitation voltage.

18.11. Check List

If the AD-4401A operates improperly, contact your local A&D dealer.

Use the chart below to write necessary items before contacting your dealer.

Checking item		Example
Weighed product		Plastic pellet, livestock feed
Capacity of the weighing instrument		20.00 kg
Minimum division of the weighing instrument		0.01 kg
Initial load on the weighing instrument		30 kg
Load cell connection method	6-wire · 4-wire	6-wire
Length of the extension load cell cable	m	Approx. 100 m
Cross section of the load cell cable	mm ²	0.5 mm ²
Number of load cells connected		3 units
Summing box	Used · Not used	Used
Load cell model number and manufacturer		LC4221-K050 A&D
Load cell rated capacity		50.99 kg
Load cell rated output	mV/V	2.0394 mV/V
Load cell input resistance	Ω	400 Ω
Load cell output resistance	Ω	350 Ω
Load cell output at initial load *1	mV/V	approx. 4.0 mV/V
Load cell output at capacity or any load. *1	at mV/V	at 20.00 kg approx. 6.8 mV/V
Control I/O	Connected to	Feed valve, lamp
Setpoint input	Connected to	
Standard serial output	Connected to	
OP-01 BCD output	Connected to	
OP-03 RS-422/485	Connected to	PLC (Mitsubishi)
OP-04 RS-232C	Connected to	
OP-07 Analog 4-20mA output	Connected to	

*1 Refer to "18.8. Checking Load Cell Input".

Digital multimeter measurement value

Measurement points		Measurement value
1 EXC+	4 EXC-	V
5 SIG+	6 SIG-	mV
1 EXC+	2 SEN+	V
4 EXC-	3 SEN-	V
6 SIG-	4 EXC-	V

19. INITIALIZATION

19.1. Parameter Initialization

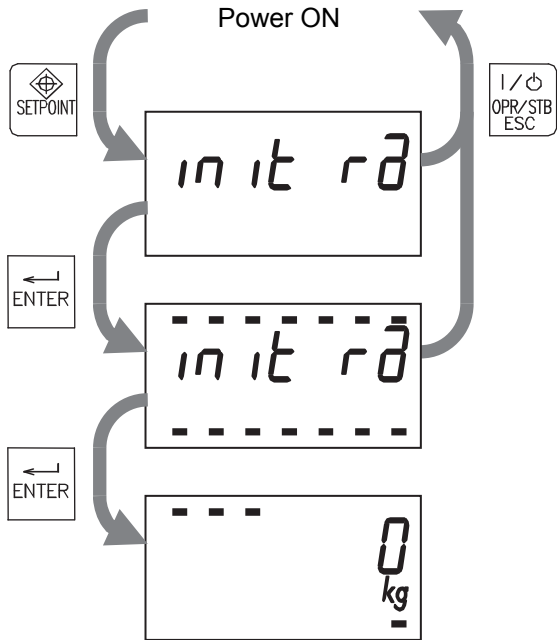

While holding the SETPOINT key, turn the AD-4401 ON.

With the display shown to the left, press the ENTER key.

With the display shown to the left, hold the ENTER key for three seconds or more to initialize the parameters below.

Zero setting value, tare value, status in the main display, normal mode/OFF mode status, total weight, number of accumulations, setpoint values, normal /loss-in-weight batching status

19.2. General Function Initialization

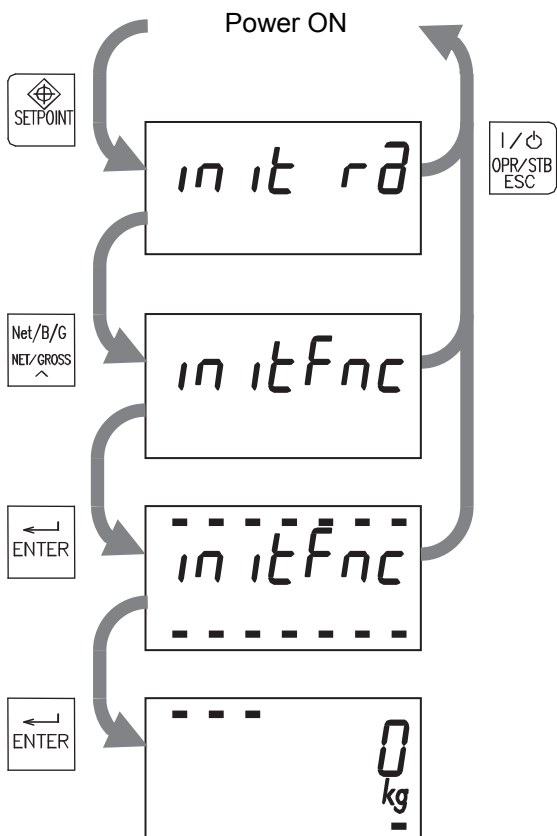

While holding the SETPOINT key, turn the AD-4401 ON.

With the display shown to the left, press the NET/GROSS key.

With the display shown to the left, press the ENTER key.

With the display shown to the left, hold the ENTER key for three seconds or more to initialize the parameters described in 19.1. and general functions.

19.3. All Data Initialization

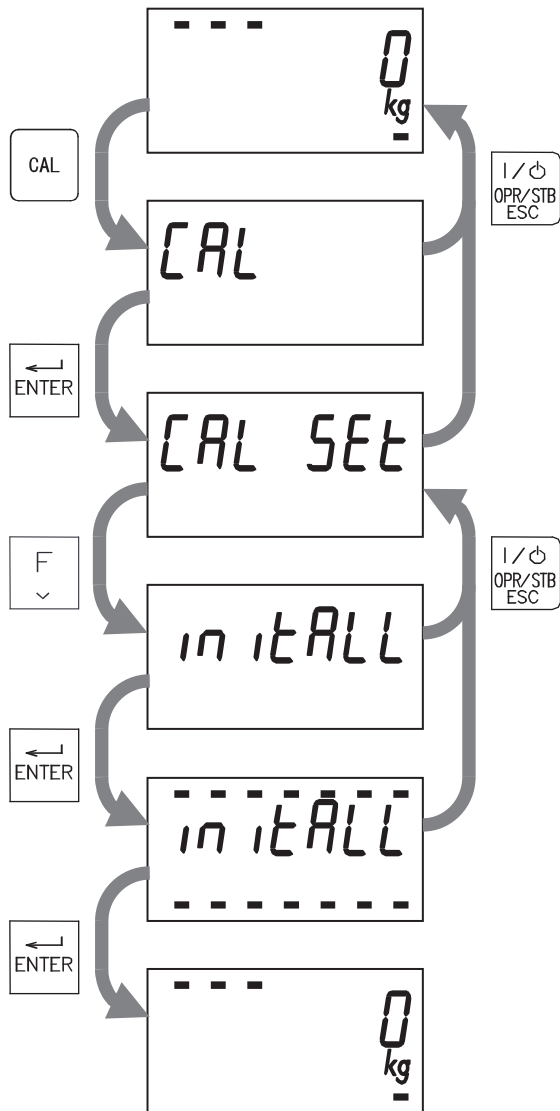

Press the CAL key in the normal mode.

When "CAL" is displayed, press the ENTER key.

When "CAL Set" is displayed, press the Function key.

When "initAll" is displayed, press the ENTER key.

With the display shown to the left, hold the ENTER key for three seconds or more to initialize the parameters described in 19.1., general functions and calibration functions

20. FUNCTION LIST

20.1. Calibration Function Setting

Set the calibration functions in the calibration function mode.

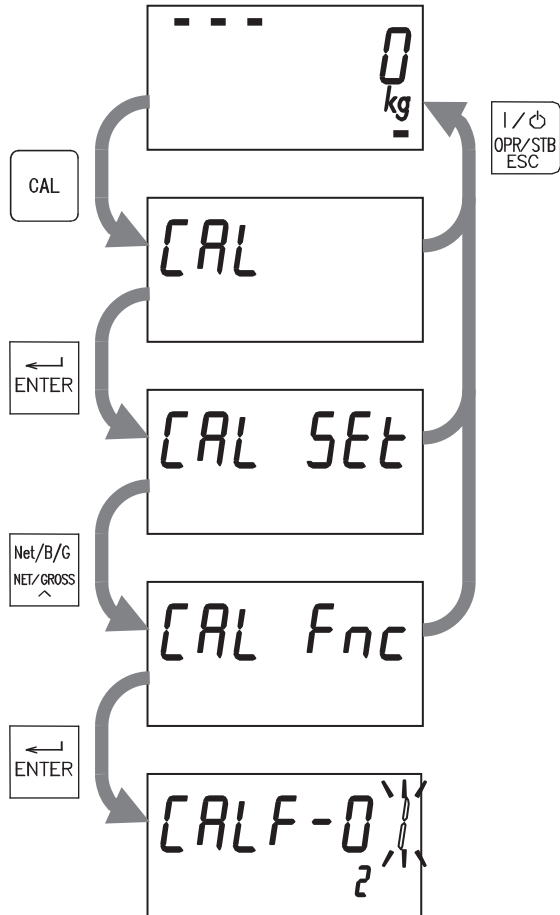

Press the CAL key in the normal mode.

When "CAL" is displayed, press the ENTER key.

When "CAL SET" is displayed, press the NET/GROSS key.

When "CAL Fnc" is displayed, the indicator has entered the calibration function mode.

Press the ENTER key to go to the item selection mode.

Operation in the calibration function mode:

Item selection	
ENTER key	Selects the displayed item and goes to the inputting mode of the item.
TARE key	Shifts the blinking item to the right.
ZERO key	Shifts the blinking item to the left.
NET/GROSS key	Increases the blinking digit by one.
Function key	Decreases the blinking digit by one.
ON/OFF key	Returns to the "Cal Set" display.
Setting value input	
ENTER key	Saves the setting value and returns to the item selection mode.
TARE key	Shifts the blinking digit to the right.
ZERO key	Shifts the blinking digit to the left.
NET/GROSS key	Increases the blinking digit by one.
Function key	Decreases the blinking digit by one.
ON/OFF key	Cancels the setting value and returns to the item selection mode.

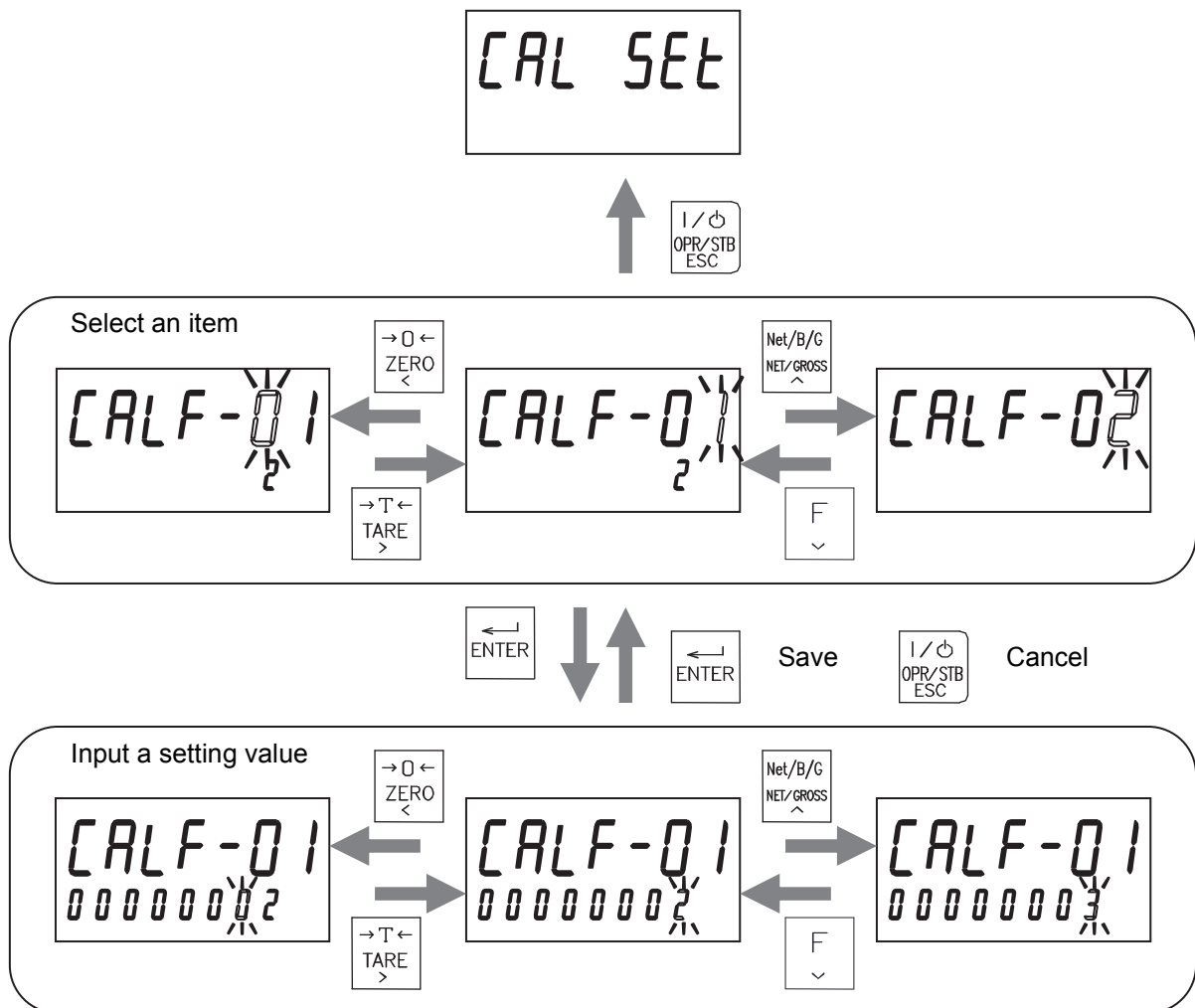

20.2. General Function Setting

Set the general functions in the general function mode.

Select a function to be set and press the ENTER key to go to the item selection mode.

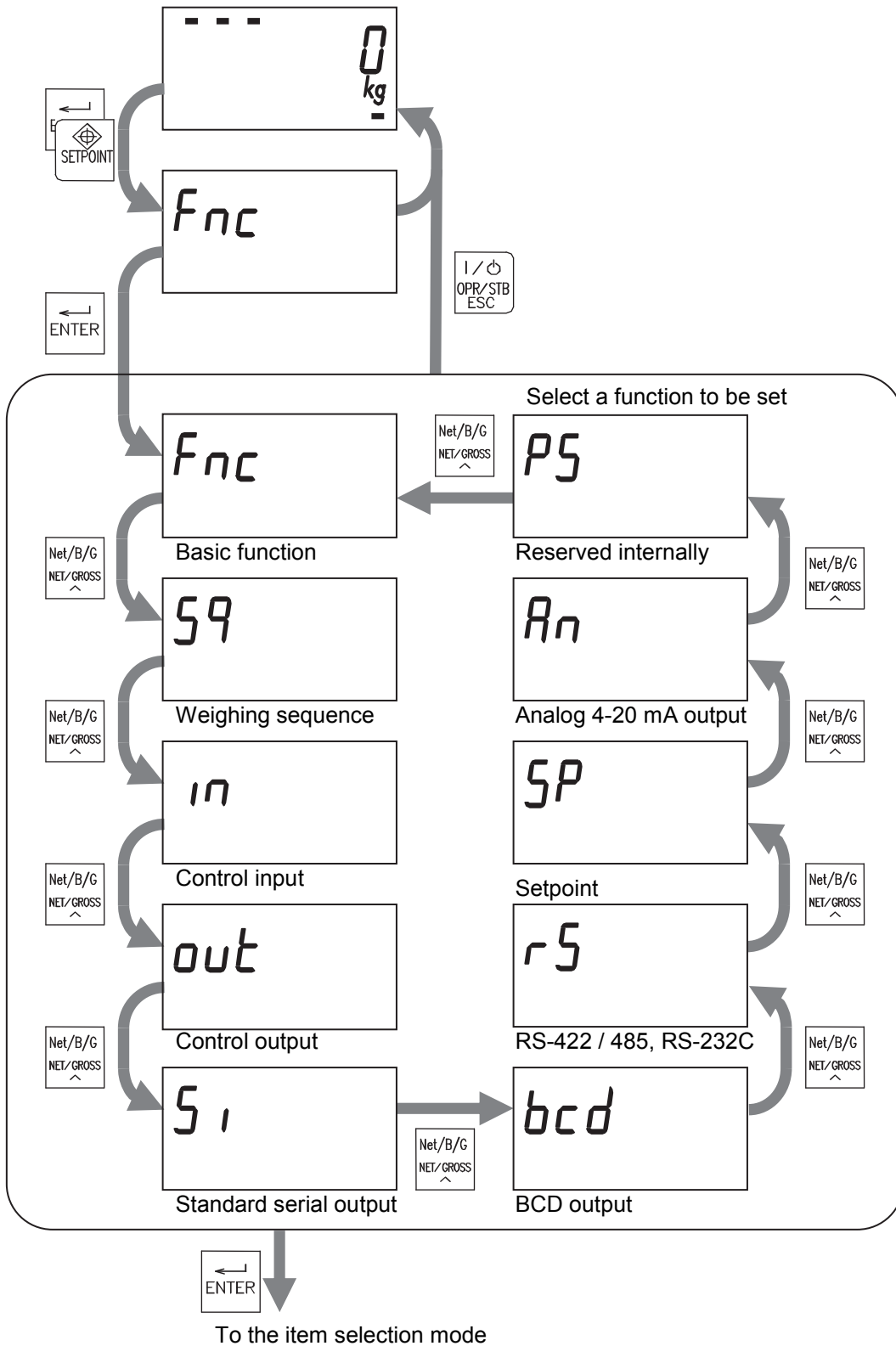

Operation:

Item selection	
ENTER key	Selects the displayed item and goes to the inputting mode of the item.
TARE key	Shifts the blinking item to the right.
ZERO key	Shifts the blinking item to the left.
NET/GROSS key	Increases the blinking digit by one.
Function key	Decreases the blinking digit by one.
ON/OFF key	Returns to the general function mode.
Setting value input	
ENTER key	Saves the setting value and returns to the item selection mode.
TARE key	Shifts the blinking digit to the right.
ZERO key	Shifts the blinking digit to the left.
NET/GROSS key	Increases the blinking digit by one.
Function key	Decreases the blinking digit by one.
ON/OFF key	Cancel the setting value and returns the item selection mode.

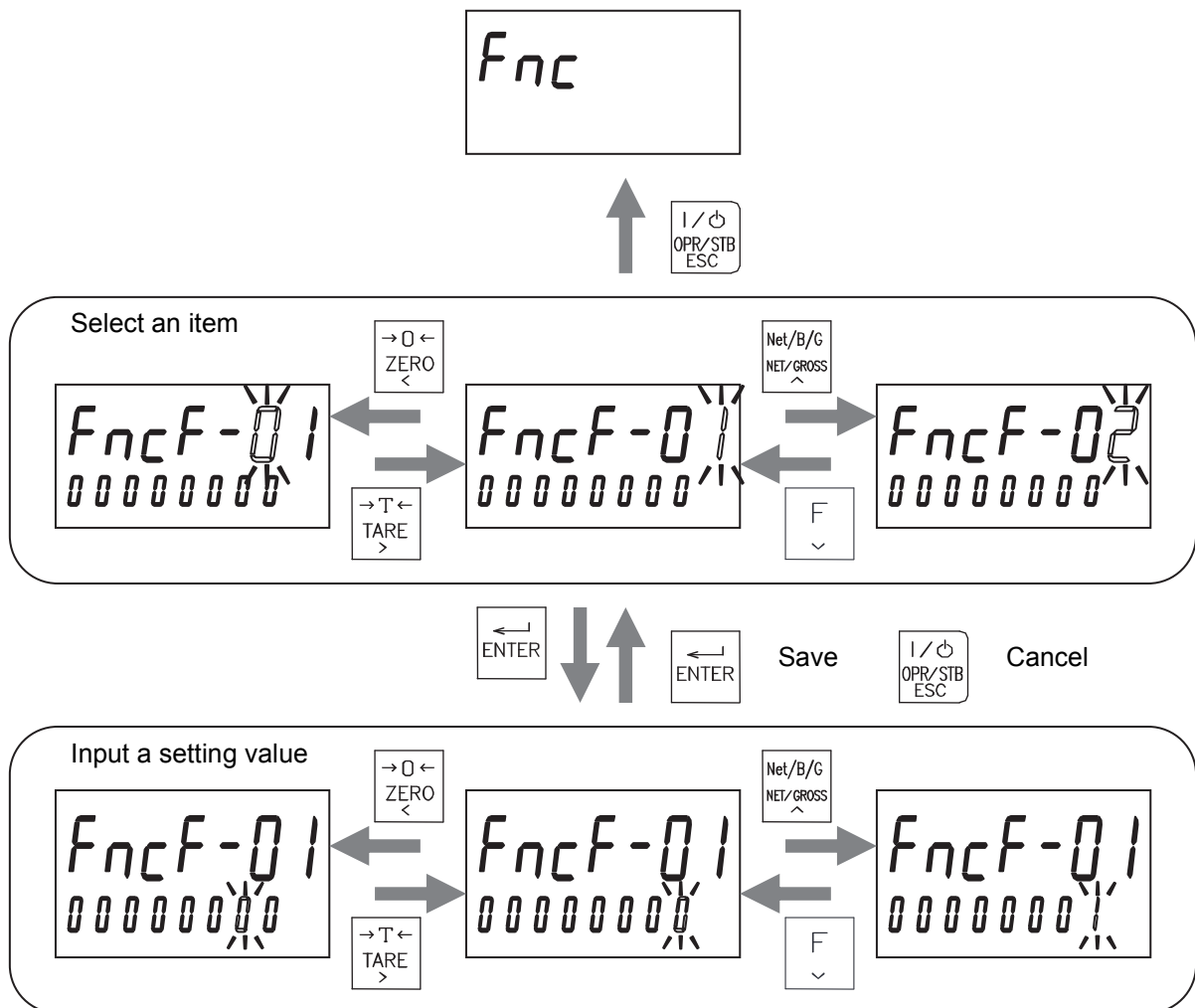

20.3. Calibration Functions

CALF	Modbus	Item	Setting Value	Default	User setting
01	400101 400102	Unit	0: None 1: g 2: kg 3: t 4: lb (For USA only)	2 (4)	
02	400103 400104	Decimal point position	0: 0 (No decimal point) 1: 0.0 2: 0.00 3: 0.000 4: 0.0000	0	
03	400105 400106	Minimum division	1, 2, 5, 10, 20, 50 d	1	
04	400107 400108	Maximum capacity	0 to 999999	20000	
05	400109 400110	Zero setting range	0 to 100%	2	
06	400111 400112	Zero tracking time	0.0: Not used 0.1 to 5.0 s	0.0	
07	400113 400114	Zero tracking width	0: Not used 1: 0.5 d 2: 1.0 d 3: 1.5 d 4: 2.0 d 5: 2.5 d 6: 3.0 d 7: 3.5 d 8: 4.0 d 9: 4.5 d	0	
08	400115 400116	Stability detection time	0.0: Not used 0.1 to 5.0 s	1.0	
09	400117 400118	Stability detection width	0: Not used 1 to 9 d	2	
10	400119 400120	Tare and zero setting at unstable weight	0: Disable 1: Enable	1	
11	400121 400122	Tare at negative gross value	0: Disable 1: Enable	1	
12	400123 400124	Standard serial output, when the weight value is overloaded or unstable.	0: Disable 1: Enable	1	
13	400125 400126	BCD, RS-422/485, RS-232C output, when the weight value is overloaded or unstable.	0: Disable 1: Enable	1	
14	400127 400128	Weighing mode	1: Simple comparison normal batching 2: Simple comparison loss-in-weight batching 3: Normal batching 4: Loss-in-weight batching 5: Check weighing 1 6: Check weighing 2 7: Check weighing 3 8: Check weighing 4	3	
15	400129 400130	Load cell signal voltage at zero calibration	0.000000 to 2.000000	0.000000	

CALF	Modbus	Item	Setting Value	Default	User setting
16	400131 400132	(Load cell signal voltage at span calibration–CALF-15) ×CALF-17/Calibration weight value at span calibration	0.000000 to 3.200000	2.000000	
17	400133 400134	Maximum capacity at span calibration	0 to 999999	20000	
18	400135 400136	Symbol used for header 2 of standard serial output	1: GS/NT/TR 2: G/N/T	1	
19	400137 400138	Symbol used for header 2 of RS-232C or RS-422/485	1: GS/NT/TR 2: G/N/T	1	
20	400139 400140	Automatic zero setting upon power-on. Zero setting range is ±10% of the maximum capacity.	0: Disable 1: Enable	0	
21	400141 400142	Zero clear	0: Disable 1: Enable	1	
22	400143 400144	Zero calibration, Span calibration and Calibration function setting via Modbus(*)	0: Disable 1: Enable	1	
23	400145 400146	Calibration weights at span calibration via Modbus.(*)	0 to 999999	20000	

* Available for the software version 1.03 or later

20.4. Basic Functions

FncF	Modbus	Item	Setting Value	Default	User setting
01	400301 400302	Key lock in the normal mode (excluding combination keys)	00000000: All keys unlock 10000000: CAL key lock 01000000: SETPOINT key lock 00100000: ZERO key lock 00010000: TARE key lock 00001000: NET/GROSS key lock 00000100: Function key lock 00000010: ENTER key lock 00000001: ON/OFF key lock	0000 0000	
02	400303 400304	Function of Function key	0: None 1: Manual print 2: Hold 3: Weighing start 4: Emergency stop 5: Zero clear 6: Tare clear 7: Total clear 8: kg/lb unit selection (For USA only) 9: Weighing restart 10: Discharge start 11: Forced weighing end 12: Forced discharge end 13: Error clear 14: Manual correction flow 15: Normal/Loss-in-weight batching selection 16: Accumulation 17: Undoing accumulation	0	
03	400305 400306	Display update rate	1: 20 times/s 2: 10 times/s 3: 5 times/s	1	
04	400307 400308	Function of sub-display	0: None 1: Gross value 2: Net value 3: Tare value 4: Final weight 5: Total weight 6: Number of accumulations 7: Weighing sequence error	0	
05	400309 400310	Condition to turn the FUNCTION status ON	0: None 1: During discharge 2: When zero tracking is enabled 3: In weighing sequence 4: Normal batching (/loss-in-weight batching)	0	

FncF	Modbus	Item	Setting Value	Default	User setting
06	400311 400312	10 ¹ digit: Pre-digital filter cutoff frequency	0: None 1: 11.0 Hz 2: 8.0 Hz	48	
		10 ⁰ digit: Post-digital filter cutoff frequency	3: 5.6 Hz 4: 4.0 Hz 5: 2.8 Hz 6: 2.0 Hz		
		Pre-digital filter and post-digital filter are connected in series.	7: 1.4 Hz 8: 1.0 Hz 9: 0.7 Hz		
		HPDF cutoff frequency	101: 11.0 Hz (HPDF) 102: 8.0 Hz (HPDF) 103: 5.6 Hz (HPDF) 104: 4.0 Hz (HPDF) 105: 2.8 Hz (HPDF) 106: 2.0 Hz (HPDF) 107: 1.4 Hz (HPDF) 108: 1.0 Hz (HPDF) 109: 0.7 Hz (HPDF)		
07	400313 400314	Sampling frequency divider ratio (Disabled when FncF-06 is 101 to 109)	1: (FncF-06)/1 2: (FncF-06)/2 3: (FncF-06)/3 4: (FncF-06)/4 5: (FncF-06)/5 6: (FncF-06)/6 7: (FncF-06)/7 8: (FncF-06)/8 9: (FncF-06)/9 10: ((FncF-06)/10	1	
08	400315 400316	Hold function	1: Normal hold 2: Peak hold	1	
09	400317 400318	Comparison at hold	0: Disable 1: Enable	0	
10	400319 400320	Condition to turn the ALARM status ON	00000000: None 00000001: Overload 00000010: Total weight / number of accumulations overflow 00000100: Zero setting error 00001000: Tare error 00010000: Weighing sequence error	0000 0111	

20.5. Weighing Sequence Functions

Sq F	Modbus	Item	Setting Value	Default	User setting
01	400401 400402	Comparison target	1: Internal value 2: Displayed weight value	1	
02	400403 400404	Automatic accumulation condition	0: Disable 1: OK only 2: Regardless of the judgment result	0	
03	400405 400406	Automatic free fall correction	0: Disable 1: Moving average of last four weighings 2: Fuzzy	0	
04	400407 400408	Automatic free fall correction range	0 to 9999999	0	
05	400409 400410	Minimum small flow time for the automatic free fall correction	0.0 to 30.0 s	3.0	
06	400411 400412	OK / Over / Under output timing	1: Always 2: In synchronization with weighing end	2	
07	400413 400414	Wait for the weight value to be stable before the judgment	0: Disable 1: Enable	1	
08	400415 400416	Maximum number of correction flow	0: Disable correction flow 1 to 300	0	
09	400417 400418	Weighing start input delay time	0.0 to 30.0 s	0.0	
10	400419 400420	Large flow comparison disable time	0.0 to 30.0 s	0.0	
11	400421 400422	Medium flow comparison disable time	0.0 to 30.0 s	0.0	
12	400423 400424	Small flow comparison disable time	0.0 to 30.0 s	0.0	
13	400425 400426	Judging delay time	0.1 to 30.0 s	0.1	
14	400427 400428	Weighing end output time	0.0: Until the next weighing start 0.1 to 30.0 s	0.0	
15	400429 400430	Flow timeout time	0: None 1: 1 to 86400 s	0	
16	400431 400432	Correction flow ON time	0.01 to 3.00 s	0.10	
17	400433 400434	Correction flow OFF time	0.1 to 30.0 s	0.1	
18	400435 400436	Discharge start input delay time	0.0 to 30.0 s	0.0	
19	400437 400438	Discharge end delay time	0.1 to 30.0 s	0.1	
20	400439 400440	Discharge timeout time	0: None 1: 1 to 86400 s	0	
21	400441 400442	Add the final weight to the near-zero setpoint value	0: Disable 1: Enable	0	
22	400443 400444	Add the final weight to the full setpoint value	0: Disable 1: Enable	0	
23	400445 400446	Reserved internally			
24	400447 400448	Simple comparison large/medium/small flow output logic	1: Positive logic 2: Negative logic	1	

Sq F	Modbus	Item	Setting Value	Default	User setting
25	400449 400450	Normal /loss-in-weight batching selection by the control input or function key	0: Disable 1: Enable	0	
26	400451 400452	Comparison target for the near-zero value	1: Gross value 2: Gross value 3: Net value 4: Net value	1	
27	400453 400454	Comparison target excluding the near-zero and full values	1: Gross value 2: Net value	2	
28	400455 400456	Automatic tare at weighing start	0: Disable 1: Enable	0	

20.6. Control Input Functions

in F	Modbus	Item	Setting value	Default	User setting
01	400501 400502	Control input function	0: None	1	
02	400503 400504		1: Zero setting 2: Tare 3: Weighing start		
03	400505 400506		4: ON = Emergency stop / OFF = Release	3	
04	400507 400508		5: Discharge start 6: ON=Disable / OFF=Enable key lock (FncF-01)		
05	400509 400510		7: Manual free fall correction	5	
06	400511 400512		8: ON=Disable / OFF=Enable reading the setpoint input. 9: Tare clear 10: Accumulation 11: Undoing accumulation 12: Total clear 13: ON=Hold / OFF=Release 14: Print 15: Zero clear 16: Gross value display 17: Net value display 18: ON=Display gross value OFF=Display net value 19: Weighing restart 20: Pause 21: Forced weighing end 22: Forced discharge end 23: Error clear 24: ON=Select loss-in-weight batching OFF=Select normal batching 25: Manual correction flow (One-shot small flow) 26: ON=Checking weighing start OFF=Checking weighing stop		

20.7. Control Output Functions

out F	Modbus	Item	Setting value	Default	User setting
01	400601 400602	Condition to turn each control output ON	0: None	1	
02	400603 400604		1: Near-zero		
03	400605 400606		2: Underweight, Hi-Hi 3: Overweight, Hi		
04	400607 400608		4: Large flow, Full, Go 5: Medium flow, Lo		
05	400609 400610		6: Small flow, Lo-Lo 7: Discharge		
06	400611 400612		8: Weighing end 9: Stable		
07	400613 400614		10: In the normal mode 11: In weighing sequence 12: Weighing sequence error		
08	400615 400616		13: 0.5 s after detecting a rise edge of the control input 14: When zero setting fails 15: Overload 16: Reserved internally 17: When tare fails 18: When zero setting or tare fails 19: Total weight / number of accumulations overflow 20: When the judgment result is OK 21: Hold 22: ON = loss-in-weight batching / Off = Normal batching		

20.8. Standard Serial Output Functions

Si F	Modbus	Item	Setting Value	Default	User setting
01	400701 400702	Output weight value	1: Displayed weight value 2: Gross value 3: Net value 4: Tare value 5: Gross value + Net value + Tare value 6: Total weight 7: Number of accumulations 8: Total weight and number of accumulations	1	
02	400703 400704	Data output timing	1: Interval output at the display update rate (FncF-03) 2: In synchronization with automatic print 3: In synchronization with manual print 4: In synchronization with automatic / manual accumulation	1	
03	400705 400706	Baud rate	1: 600 bps 2: 2400 bps	2	
04	400707 400708	Standard serial output slave address	0: None 1 to 99	0	

20.9. BCD Output Functions

bCdF	Modbus	Item	Setting Value	Default	User setting
01	400801 400802	Output weight value	1: Displayed weight value 2: Gross value 3: Net value 4: Tare value	1	
02	400803 400804	Data output timing	1: Interval output at the display update rate (FncF-03) 2: In synchronization with automatic print 3: In synchronization with manual print	1	
03	400805 400806	Data output logic	1: Positive logic 2: Negative logic	2	
04	400807 400808	Strobe output logic	1: Positive logic 2: Negative logic	2	

20.10. RS-422/485, RS-232C Functions

rS F	Modbus	Item	Setting Value	Default	User setting
01	400901 400902	Output weight value	1: Displayed weight value 2: Gross value 3: Net value 4: Tare value 5: Gross value + Net value + Tare value 6: Total weight 7: Number of accumulations 8: Total weight and number of accumulations	1	
02	400903 400904	Communication type	1: Interval output at the display update rate (FncF-03) 2: In synchronization with automatic print 3: In synchronization with manual print 4: Response to command 5: Interval output of comparison result and gross value at 100 times/s 6: Interval output of comparison result and net value at 100 times/s. 7: In synchronization with automatic/manual accumulation 8: Interval output at 100 times/s 9: Modbus-RTU	1	
03	400905 400906	Baud rate	1: 600 bps 2: 1200 bps 3: 2400 bps 4: 4800 bps 5: 9600 bps 6: 19200 bps 7: 38400 bps 8: 115200 bps	5	
04	400907 400908	Parity	0: None 1: Odd 2: Even	2	
05	400909 400910	Character bit length	7: 7 bits 8: 8 bits	7	
06	400911 400912	Stop bit length	1: 1 bit 2: 2 bits	1	
07	400913 400914	Terminator	1:CR 2:CR LF	2	
08	400915 400916	RS-422/485 electrical specifications	1: RS-422 (rS F-09=0) 1: 4-wire RS-485 (rS F-09 ≠ 0) 2: 2-wire RS-485	1	
09	400917 400918	RS-422/485 slave address	0: None 1 to 99	0	
10	400919 400920	Command Response delay time	0.00 to 3.00 s	0.06	

20.11. Setpoint Input Functions

SP F	Modbus	Item	Setting Value	Default	User setting
01	401001 401002	Setpoint setting method	0: Setpoint input not used 1: 5-digit input from external devices 2: 16-digit input from external devices	0	

20.12. Analog 4-20 mA Output Functions

An F	Modbus	Item	Setting Value	Default	User setting
01	401101 401102	Output weight value	1: Displayed weight value 2: Gross value 3: Net value	1	
02	401103 401104	Weight value at 4 mA output	-999999 to 9999999	0	
03	401105 401106	Weight value at 20 mA output	-999999 to 9999999	20000	

21. SPECIFICATIONS

Dimensions	144 (W) x 72 (H) x 197 (D) mm
Operating temperature and humidity range	-10 °C to 40 °C Less than 85%RH, non-condensing
IP rating	When the indicator is secured to the control panel: Outside of the control panel: IP65 Inside of the control panel: IP2X
Power supply	
Power supply voltage	100 VAC to 240 VAC +10% -15%, 50/60 Hz ±5%
Maximum apparent power	30 VA
Rush current	100 VAC: 15 A or less, 200 VAC: 30 A or less
Fuse	Internal (Not user replaceable)
Load cell input	
Excitation voltage	10 VDC±5% 230 mA Up to eight 350 Ω load cells can be connected in parallel. 6-wire type with remote sensing
Signal input range	0.0 to 3.2 mV/V
Minimum input sensitivity	0.3 μV
Zero calibration range	0.0 to 2.0 mV/V
Nonlinearity	±0.01%
Temperature coefficient	Zero drift: ±0.2 μV/°C RTI Typ., Span drift: ±8ppm/°C Typ.
Sampling rate	100 times/s
Display	
Main display	7-digit VFD with character height of 13 mm
Sub-display	8-digit VFD with character height of 7 mm
Unit	g, kg, t, lb (For USA only) or none (selectable)
Status display	14
Key switches	
Key switch	7
Key switch with sealing cover	1
External Input / output	
Control I/O	Non-voltage contact input: 6 points NPN open collector: 8 points
Setpoint input	Key matrix input
Standard serial output	Current loop output
Option boards	
BCD output	A slot is available only for analog 4-20 mA output. Among other option boards, only one can be installed.
RS-422/485	
RS-232C	
Analog 4-20 mA output	

External dimensions

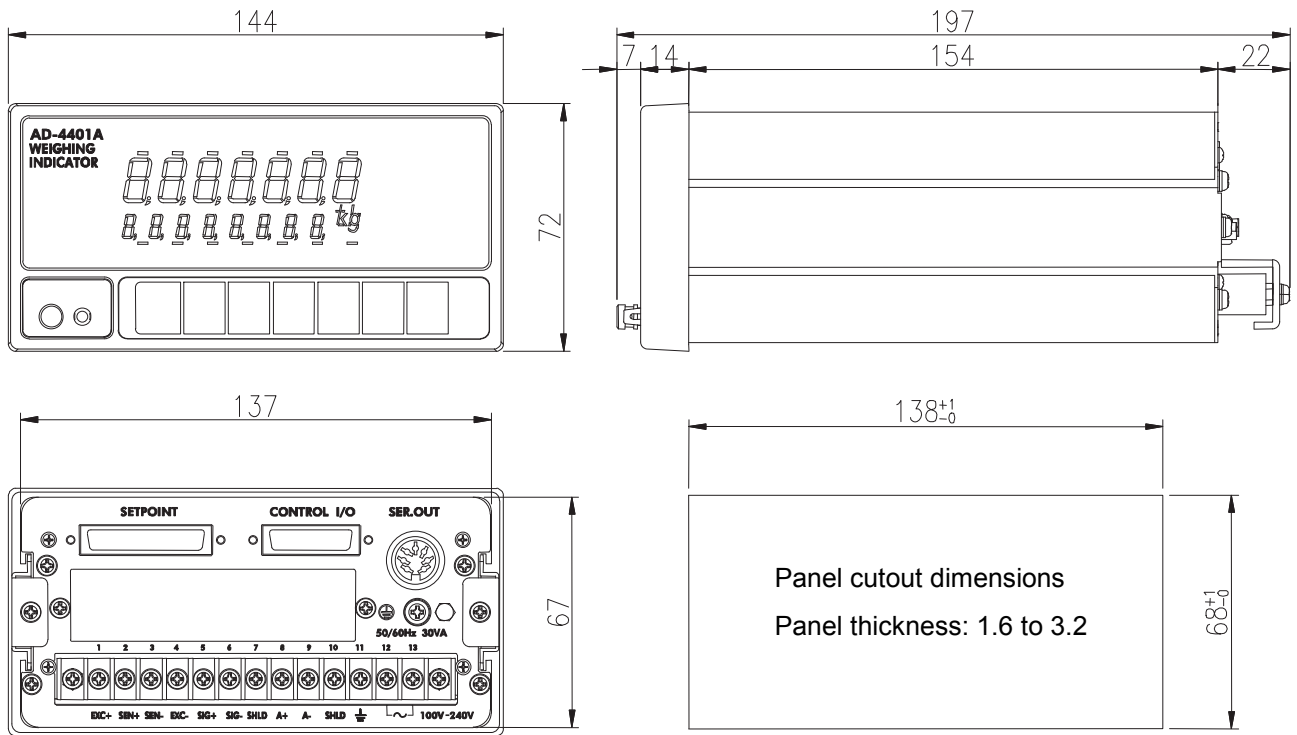

Unit: mm



A&D Company, Limited

3-23-14 Higashi-Ikebukuro, Toshima-ku, Tokyo 170-0013, JAPAN
Telephone: [81] (3) 5391-6132 Fax: [81] (3) 5391-6148

A&D ENGINEERING, INC.

1756 Automation Parkway, San Jose, California 95131, U.S.A.
Telephone: [1] (408) 263-5333 Fax: [1] (408)263-0119

A&D INSTRUMENTS LIMITED

Unit 24/26 Blacklands Way, Abingdon Business Park, Abingdon, Oxfordshire OX14 1DY United Kingdom
Telephone: [44] (1235) 550420 Fax: [44] (1235) 550485

A&D AUSTRALASIA PTY LTD

32 Dew Street, Thebarton, South Australia 5031, AUSTRALIA
Telephone: [61] (8) 8301-8100 Fax: [61] (8) 8352-7409

A&D KOREA Limited

한국에이.엔.디(주)
서울특별시 영등포구 국제금융로6길33 (여의도동) 맨하탄빌딩 817 우편 번호 150-749
(817, Manhattan Bldg., 33. Gukjegeumyung-ro 6-gil, Yeongdeungpo-gu, Seoul, 150-749 Korea)
전화: [82] (2) 780-4101 팩스: [82] (2) 782-4280

ООО A&D RUS

ООО "ЭЙ энд ДИ РУС"
121357, Российская Федерация, г.Москва, ул. Вереysкая, дом 17
(Business-Center "Vereyskaya Plaza-2" 121357, Russian Federation, Moscow, Vereyskaya Street 17)
тел.: [7] (495) 937-33-44 факс: [7] (495) 937-55-66

A&D INSTRUMENTS INDIA PRIVATE LIMITED

509, उद्योग विहार , फेस -5, गुडगांव - 122016, हरियाणा , भारत
(509, Udyog Vihar, Phase-V, Gurgaon - 122 016, Haryana, India)
फोन : 91-124-4715555 फैक्स : 91-124-4715599

ऐ&डी इन्स्ट्रुमेन्ट्स इण्डिया प्रा० लिमिटेड