

2024

Issue date 7Aug2024

Scales & Balances



*The weigh you want... **today***

the weigh you want... *today!*



Dear Customer:

This catalog has been prepared especially for the professional in the weighing industry. I think that you will find it informative and helpful.

We pride ourselves on answering the phone on the first ring and shipping your order the same day that you place it. This is due to our huge inventory.

You can depend on our price being the best in the industry. If you have a need for a large quantity we can give you a better price.

Thank you for being our customer. We look forward to many successful years with you.

Best Personal Regards
Rudolph J. Kolaci
President

Compact

Bench

Bench/Floor

Floor

Portable

UPS

POS

Portion

Computing

Over/Under

Counting

Baggsge

Animal

Health

Postal

Jewelry

Lift Truck

Pallet Truck

Race Car

Aircraft

Wheeload

Hanging

Crane

Link

Precision

Moisture

Industrial

Analytical

Mechanical

Scoops

Covers

Mark-10

Mission

Serve, Supply, & Inform You with Totalcomp**etence**.

Vision

Embrace Change While Maintaining Values.

Values

Honest in all of our dealings.

Helpful to our customers & each other.

Happy in both home and office.

Healthy in all aspects of our lives.

To see current dealer pricing please go to ***www.Totalcomp.com*** and create an account.

After dealer approval, you will be able to order online as an authorized Totalcomp reseller.

Please feel free to call us at 800-631-0347 should you have any issues successfully registering.

Compact



HH320
Compact Scale

OHAUS®

HH Hand Held compact scale

Convenient, compact and portable for briefcase, backpack or pocket. Standard model HH120 for basic grams weighing. Professional HH320 has multiple weighing units for g, oz, dwt, ozt. Backlit display and protective cover. Large high contrast LCD display. Low battery indicator, overload and underload indicators, (2) "AAA" batteries, rugged plastic construction. The letter "D" in the part number indicates a User Calibration Feature. 1 year warranty.

Part Number	Capacity	Platform	Weight	SKU	List
HH120D	0-60g x 0.1g	3.25" x 3"	1 lb	4156	\$ 238.00
	60-120g x 0.2g				
HH120	120g x 0.1g	3.25" x 3"	1 lb	2312	284.00
HH320	320 x 0.1g	3.25" x 3"	1 lb	4157	313.00



PS
Compact Scale

OHAUS®

PS Compact scale

Unique pan design, durable ABS housing slides back to engage the load cell and expose the display and buttons for operation. Weighing units for g, oz, ozt, dwt. 0.3" LCD display. Text weight unit prompts with stability and overload indicators. Auto shut off to preserve battery. Cover protects display and keys and prevents load cell damage in transport. Smaller than most pocket scales, allows a comfortable fit in your pocket. Piano style mechanical buttons provide positive dependable operation. Includes calibration software using 100g weight for PS121 and 200g weight for PS251. Calibration weights are not included. Two CR2032 lithium batteries included. 1 year warranty.

Part Number	Capacity	Platform	Weight	SKU	List
PS121	120g x 0.1g	2.8" x 2.5"	1 lb	2329	\$ 97.00
PS251	250g x 0.1g	2.8" x 2.5"	1 lb	2330	125.00



CX Compact scale

Compass offers a battery life of up to 1,000 continuous hours, allowing for uninterrupted operation. Featuring a slim, stackable and light-weight design, two-button operation. The Compass CX's large backlit display increases readability in dim lighting conditions.

Part Number	Capacity	Platform	Weight	SKU	List
CX221	220 x 0.1 g	5" x 5.6"	2 lb	2876	\$ 211.00
CX621	620 x 0.1 g	5" x 5.6"	2 lb	2877	218.00
CX1201	1,200 x 0.1 g	5" x 5.6"	2 lb	2878	231.00
CX2200	2,200 x 1.0 g	5" x 5.6"	2 lb	2879	211.00
CX5200	5,200 x 1.0 g	5" x 5.6"	2 lb	2880	249.00

Models followed by the letter P include a postal chart

CX221P	220 x 0.1 g	5" x 5.6"	2 lb	2881	226.00
CX2200P	2,200 x 1.0 g	5" x 5.6"	2 lb	2882	227.00
CX5200P	5,200 x 1.0 g	5" x 5.6"	2 lb	2883	249.00

Culinary Scale

CX5200F	5,200 x 1.0 g	5" x 5.6"	2 lb	2884	285.00
---------	---------------	-----------	------	------	--------

Options

30467763 Carrying Case			2 lb	2874	87.00
80850075 Bowl 1050ml			1 lb	4226	73.00
30330714 Adaptor 5v 1A US plug			1 lb	2740	35.00
12102565 Carat bowl XS aluminum			1 lb	2885	30.00
30020842 Carat bowl XS Gold			1 lb	1141	46.00



CX Compact Scale

Compact



CR
Compact scale

OHAUS®

CR Compass compact scale

Compass offers basic weighing functionality and competitive performance. Features such as a slim, stackable design, and an enlarged weighing platform, perfect for a variety of portable weighing applications. Stack up to 4 scales.

Part Number	Capacity	Platform	Weight	SKU	List
CR221	220 x 0.1 g	5" x 5.2"	2 lb	2870	\$ 151.00
CR621	620 x 0.1 g	5" x 5.2"	2 lb	2871	156.00
CR2200	2,200 x 1.0 g	5" x 5.2"	2 lb	2872	151.00
CR5200	5,200 x 1.0 g	5" x 5.2"	2 lb	2873	208.00

Options

30467763 Carrying Case			2 lb	2874	87.00
80850075 Bowl 1050ml			1 lb	4226	73.00
30467987 Adaptor w/plugs(EU,US,UK,AU,KR)			1 lb	2875	53.00

Totalcomp



MH-200
Pocket scale

MH Pocket scale

The best pocket scale on the market, extreme accuracy for an incredibly low price. Competitive units sell for \$100 with a capacity of 100g x 0.01g. While this unit sells for \$79.99 with a capacity of 200g x 0.01g. Accurate weight readings in a fraction of a second. Zero's out in half the time of other units. Lightweight and portable. Can be stored in your pocket or backpack for easy transport. Perfect for jewelry, herbs, or anything you need to weigh up to 200g. (2) AAA batteries, included.

Part Number	Capacity	Platform	Weight	SKU	List
MH-200	200g x 0.01 g	1.9" x 2.2"	0.24 lb	5294	\$ 79.99



A&D WEIGHING DIVISION

HL Compact Scale

Use in a wide range of applications including office, warehouse, laboratory and industry. Keys for ON/OFF, UNITS, RE-ZERO. Liquid crystal display(LCD) can be selected to various weighing modes which can include g, lb oz. Self contained, battery operated by (6) AA batteries or an optional AC adapter 120 VAC, 50/60 Hz, 1.5 watts. Auto shut off after 5 minutes. 7.8"W x 5.51"D x 1.75"H
NTEP Legal for Trade (select models)

Part Number	Capacity	Platform	Weight	SKU	List
Stainless Steel Full Washdown IP65 NEMA-4X					
HL-300WP	300 x 0.1g	5" x 5"	3 lb	6617	490.00
HL-1000WP	1,000 x 0.5g	5" x 5"	3 lb	6618	490.00
HL-3000WP	3,000 x 1g	5" x 5"	3 lb	6619	480.00
HL-3000WPN *	3,000 x 1g	5" x 5"	3 lb	6620	480.00
HL-3000LWP	3,000 x 1g	5.4" x 6.8"	4 lb	6621	475.00
HL-3000LWPN *	3,000 x 1g	5.4" x 6.8"	4 lb	6622	475.00

* N suffix does not have lb/oz mode and is NTEP

Service Parts

04:3006434 SS pan 5" x 5"	1 lb	6676	22.00
07:4014219 adjustable foot	1 lb	6677	10.00



HL-300WP
Stainless Steel Washdown
Compact Scale



A&D WEIGHING DIVISION

HLi Ninja Compact Scale

Portable, battery operated. Simple, easy to operate. Clear 0.53" 7 segment LCD display. Keys are: ON/OFF, UNITS, O/T/RE-ZERO. Units: g, oz, tl. HL-200i has additional units of g. Indicators are: low batt, weight stability, scale overload. 1,000 hours of battery life. Auto power off. 2 year warranty. Includes (4) AA batteries, optional AC adapter. 5.1"W x 7.6"D x 2"H

Part Number	Capacity	Pan	Weight	SKU	List
HL-200i	200 x 0.1g	5.1" dia	2 lb	5360	\$ 125.00
HL-2000i	2,000 x 1g	5.1" dia	2 lb	5361	125.00

Options

TB:662 AC adapter 120 VAC	1 lb	1305	45.00
FV-06 AC adapter 240VAC	1 lb	1306	55.00



HL-200i
Compact Scale

Prices are subject to change without notice. Please call for current prices.

Other items are available from the manufacturers, please call for prices.

13-01 Pollitt Dr Ext
Fair Lawn NJ 07410
201-797-2718

Totalcomp
Scales & Balances

www.totalcomp.com
sales@totalcomp.com
Fax 201-797-2287



A&D WEIGHING DIVISION

HT Compact Bench Scale

Engineered with simplicity in mind. Low profile and lightweight. Designed with portability and protection. Unique to this scale are 3 included color bars that allow the user to categorize the scale by user or function. Choose one of the 3 color bars (red, green, orange) to personalize your scale. Clearly visible, 13.5mm high digital LCD display. Multiple units of measure for: g, oz, Troy oz, lb, lb-oz, N, tael, tola. Auto power off function to preserve battery life. 450 hour battery life (4AA batteries included). Standard plastic carrying case included that are stackable for easy storage. It is even possible to weigh on the scale as it rests in the case, no need to remove it. The case also comes with penholders for added convenience. Security slot in the rear of the scale can accommodate an anti-theft device. 7.68"W x 5.35"D x 1.73"H



**HT-500
Bench Scale**

Part Number	Capacity	Platform	Weight	SKU	List
HT-120	120 x 0.01g	2.75" x 5.12"	3 lb	4228	\$ 296.00
HT-300	310 x 0.1g	5.20" x 5.12"	3 lb	4278	155.00
HT-500	510 x 0.1g	5.20" x 5.12"	3 lb	4279	185.00
HT-3000	3,100 x 1g	5.20" x 5.12"	3 lb	4280	155.00
HT-5000	5,100 x 1g	5.20" x 5.12"	3 lb	4281	185.00
Options					
HT-10	Stainless steel pan	5.20" x 5.12"	2 lb	4290	35.00
TB:662	AC adapter 120 VAC		1 lb	1305	45.00



A&D WEIGHING DIVISION

SJ Bench Scale

Full digital calibration, large, removable stainless steel pan. Easy to read 1" 7 segment LCD display. Less than one second response. Keys for ON/OFF, RE-ZERO, UNITS. Weighing units are: g, oz, lb-oz, lb. 800 hour battery life. Battery level indicator. Automatic power off. Optional AC adapter (not included). 10.4"W x 9.8"D x 4.1"H.



**SJ-2000HS
Bench Scale**

Part Number	Capacity	Pan	Weight	SKU	List
SJ-1000HS	1,000 x 0.5g	230 x 190mm	4 lb	4093	\$ 265.00
SJ-2000HS	2,000 x 1g	230 x 190mm	4 lb	4096	265.00
SJ-5000HS	5,000 x 2g	230 x 190mm	4 lb	4097	265.00
SJ-5001HS	5,000 x 1g	230 x 190mm	4 lb	4036	296.00
SJ-12KHS	12,000 x 5g	230 x 190mm	4 lb	4099	265.00
SJ-20KHS	20,000 x 10g	230 x 190mm	4 lb	4094	315.00
SJ-30KHS	30,000 x 20g	230 x 190mm	4 lb	4095	315.00
Options					
TB:662	AC adapter 120 VAC		1 lb	1305	45.00
Service Parts					
07:4018232A	foot for SJ old version		1 lb	5798	10.00
707:4018232	foot for SJ w/rubber insert		1 lb	5883	10.00
07:3008539	battery cover for SJ		0.03 lb	5886	18.57



A&D WEIGHING DIVISION

EK-i Bench Scale

1/30,000 resolution and a complete range of features from a scale portable enough to carry in one hand. Gram, oz(avoird), oz(troy), lb, grain, carat, momme, tael, pennyweight, counting function, Percentage Function. Includes RS232C interface to communicate with computers and printers. Includes AC adapter. 115VAC, 50/60 Hz, 2.5VA, 7.5"W x 8.6"D x 2.6"H.

NTEP Legal for Trade 04-019 Class III & II

Part Number	Capacity	Pan	Weight	SKU	List
EK-120i*	120 x 0.01g	4.3"dia	4 lb	5647	\$ 580.00
EK-200i*	200 x 0.01g	4.3"dia	4 lb	5648	625.00
EK-300*i	300 x 0.01g	4.3"dia	4 lb	5649	650.00
EK-410i*	400 x 0.01g	4.3"dia	4 lb	5226	730.00
EK-610i*	600 x 0.01g	4.3"dia	4 lb	5227	860.00
EK-600i	600 x 0.1g	5.2" x 6.7"	5 lb	5650	595.00
EK-1200i	1,200 x 0.1g	5.2" x 6.7"	5 lb	5651	585.00
EK-2000i*	2,000 x 0.1g	5.2" x 6.7"	5 lb	5652	630.00
EK-3000i*	3,000 x 0.1g	5.2" x 6.7"	5 lb	5653	685.00
EK-4100i*	4,000 x 0.1g	5.2" x 6.7"	5 lb	5228	820.00
EK-6100i*	6,000 x 0.1g	5.2" x 6.7"	5 lb	5229	995.00
EK-6000i	6,000 x 1g	5.2" x 6.7"	5 lb	5654	650.00
EK-12Ki	12,000 x 1g	5.2" x 6.7"	5 lb	5655	825.00

* Not NTEP

Options

EKW-04i Comparator/Relay output/Buzzer	1 lb	5656	195.00
EKW-07i Underhook for EK-6000i & 12Ki	1 lb	5657	60.00
EKW-09i Rechargeable NiCd battery pack	4 lb	5658	245.00
AX: 3005824-5S Protective in use cover	1 lb	5231	16.00
EJ-12 Carry case for EW/EK-i	2 lb	7555	75.00
AD-100-2 Anti theft device	1 lb	1849	90.00

Service Parts

TB:662 AC adapter 120VAC	1 lb	1305	45.00
06:4011084B-2 foot EK EW EJ	1 lb	6176	10.00
04:4007526 pan 5.2"x6.7"	1 lb	5614	43.00
07: A46041A adjustable foot EKA EKG EWG EWH	1 lb	6184	15.50
07:4000316 display filter EK EW	0.02 lb	6311	10.00
08:3005577 keysheet EK1	0.02 lb	6312	27.00



**EK-12Ki
Bench Scale**



A&D WEIGHING DIVISION

EK (Old) Bench Scale

Old Series parts only.

Part Number	Weight	SKU	List
Old Version Service Parts			
01:A33711-2A keysheet EK-1200A	1 lb	1503	\$ 28.00
01:A33744 keysheet for EK-12KA	1 lb	1956	31.00
PZ:690 Pushbutton assy for EK/EW Series	1 lb	18	39.00
AX:00A20559A protective dust cover for EK/EW 120/1200	1 lb	1674	12.00

Prices are subject to change without notice. Please call for current prices.

Other items are available from the manufacturers, please call for prices.

13-01 Pollitt Drive Ext
Fair Lawn NJ 07410
201-797-2718 * 800-631-0347

Totalcomp
Scales & Balances

www.totalcomp.com
sales@totalcomp.com
Fax 201-797-2287



T29 Washdown Bench Scale



T29 Washdown Bench Scale

Stainless steel housing with steel case, locks out water, dust and dirt. Portable. Washdown with breathable knob design. Designed to withstand a variety of harsh conditions found in commercial and industrial facilities (tighten knob for complete seal). Large 25mm LCD display with white LED backlight make this scale easy to read. Keys for ON/OFF, TARE, ZERO. Indicators for Zero, Stable, Net, Battery, kg, lb, charging LED light. Adjustable feet and front bubble level makes it easy to level this scale. 6V/3.2Ah rechargeable battery included. Battery provides up to 70 hours of continuous use (without backlight). 12V/500mA AC adapter included. Operating temperature -10 C to +40 C. IP67. 9.5"W x 11.75"D x 5"H.

Part Number	Capacity	Platform	Weight	SKU	List
T29-6 lb	6 x 0.001 lb	7.5" x 9.0"	10 lb	7982	\$ 434.50
T29-12 lb	12 x 0.002 lb	7.5" x 9.0"	10 lb	7983	434.50
T29-24 lb	24 x 0.005 lb	7.5" x 9.0"	10 lb	7984	434.50
T29-30 lb	30 x 0.005 lb	7.5" x 9.0"	10 lb	7985	434.50
T29-60 lb	60 x 0.01 lb	7.5" x 9.0"	10 lb	7986	434.50

Options

AC Adapter 12VDC	1 lb	6362	26.18
------------------	------	------	-------

Service Parts

Main board for T29	1 lb	7592	209.00
110200050 battery for T29 6v/3.2a	1.42 lb	7366	23.00



A&D WEIGHING DIVISION



EW-1500i Bench Scale



EW-i Bench Scale

The EW-i Series scales offer attractive triple ranges at an even more economical price. Weighing modes include gram(g), decimal ounce(oz), decimal pound(lb), troy ounce(ozt), pennyweight(dwt), carat(ct), Momme(mm), Grain Unit(GU), tael(tl), percentage and counting functions. Includes RS-232C interface for connecting computers and printers. Includes AC adapter, 115 VAC 50/60 Hz, 2.5 VA, 7.5"W x 8.6"D x 2.2"H. NTEP Legal for Trade 04-019 Class III

Part Number	Capacity	Pan	Weight	SKU	List
EW-150i *	30g x 0.01g 60g x 0.02g 150g x 0.05g	4.3" dia	4 lb	5644	\$ 490.00
EW-1500i	300g x 0.1g 600g x 0.2g 1,500g x 0.5g	5.2" x 6.7"	5 lb	5645	490.00
EW-12Ki	3,000g x 1g 6,000g x 2g 12,000g x 5g	5.2" x 6.7"	5 lb	5646	490.00

* Not NTEP

Options

EKW-04i Comparator/Relay output/Buzzer	1 lb	5656	195.00
EKW-07i Underhook for EK-6000i & 12Ki	1 lb	5657	60.00
EKW-09i Rechargeable NiCd battery pack	4 lb	5658	245.00

AX: 3005824-5S Protective in use cover	1 lb	5231	16.00
EJ-12 106 Carry case for EW/EK-i	2 lb	7555	75.00
AD-100-2 Anti theft device	1 lb	1849	90.00

Service Parts

TB:662 AC adapter 120VAC	1 lb	1305	45.00
--------------------------	------	------	-------

Prices are subject to change without notice. Please call for current prices.

Other items are available from the manufacturers, please call for prices.



A&D WEIGHING DIVISION

SK-WP Water Proof Bench Scale

Stainless steel, rugged, high impact housing. Detachable stainless steel weighing pan. Large & clear LCD display 25mm high. Portable with (6) D size batteries (not included). Approx. 600 hours (manganese type), 1,200 hours (alkaline). Indicators for Stable. Net, Zero and Low battery. Keys for ON/OFF, ZERO, TARE. Auto power off function. SK-Z is LB w/decimal oz, fractional oz, decimal lb. Optional AC adapter (not included). 10.5"W x 11"D x 5.75"H.

NTEP Legal for Trade 98-086 Class III,
NSF pending

Part Number	Capacity	Pan	Weight	SKU	List
SK-1000WP	1,000 x 0.5g	232 x 192mm	8 lb	2936	\$ 496.00
SK-2000WP	2,000 x 1g	232 x 192mm	8 lb	2937	510.00
SK-5000WP	5,000 x 2g	232 x 192mm	8 lb	2938	510.00
SK-5001WP*	5,000 x 1g	232 x 192mm	8 lb	2939	510.00
SK-10KWP	10kg x 0.005kg	232 x 192mm	8 lb	2940	496.00
SK-20KWP	20kg x 0.01kg	232 x 192mm	10 lb	2941	520.00

*not NTEP

Options

TB:662 AC adapter 120 VAC	1 lb	1305	45.00
FV-06 AC adapter 220 VAC	1 lb	1306	55.00

Service Parts

08:3005664A Keypad overlay for SK2000WP	1.lb	3028	12.00
07:2000638 battery cover SKWP	1 lb	2935	22.00
PZ:4334 main board SKWP	1 lb	2947	133.00
07:4011266A adjustable foot	0.05 lb	2986	21.86

Load cells

LC:121-2000WP for SK1000WP,SK2000WP	1.lb	2888	119.00
LC:121-10KWP for SK5000WP,SK5001WP, and SK10KWP	1.lb	2889	119.00
LC:121-20KWP for SK20KWP	1.lb	2890	119.00



**SK-WP
Bench Scale**



A&D WEIGHING DIVISION

FV + FW Portable Bench/Floor Scale

Service parts only.

HV: NTEP Legal for Trade 96-186 III 3,100 div Canadian SWA# AM-5093

Part Number	Weight	SKU	List
Service parts (Old Units FV & FW)			
01A Wall mounting kit for display pod(FV/FW)	1 lb	1268	\$ 45.00
02 Display pod extension cable 5m	1 lb	1302	139.00
09:A34157-7 Keysheet unit for FV	1 lb	1495	93.00
06:A33710-1A rubber cushion small for FV	1 lb	1462	17.00
06:A33710-2A rubber cushion large for FV	1 lb	1463	20.00

Prices are subject to change without notice. Please call for current prices.

Other items are available from the manufacturers, please call for prices.

13-01 Pollitt Dr Ext
Fair Lawn NJ 07410
201-797-2718



www.totalcomp.com
sales@totalcomp.com
Fax 201-797-2287



A&D WEIGHING DIVISION



EJ-200



EJ-2000



EK-120G

Service Parts only

EJ Bench Scale

Ten different capacities cover a broad range of applications for your user requirements. Easy to read, 16mm high LCD display with amber backlight allows for easy viewing in the worst conditions. Fast, 1 second response time. Keys for: ON/OFF, SAMPLE, PRINT, OT/RE-ZERO, PRINT. Weighing units are: grams, ounces, pounds, troy ounces, carats, momme, pennyweight, grains, newtons, tael. Counting mode with Automatic Counting Accuracy Improvement (ACAI). Percent weighing. Specific gravity function. Over-Under. Stackable (up to 3 high) for easy storage and retrieval. 5 year warranty.

Part Number	Capacity	Pan	Weight	SKU	List
EJ-54D2	22g x 0.0002g 52g x 0.001g	1.96"	3 lb	7670	\$ 735.00
EJ-123	120g x 0.001g	4.3"	4 lb	7626	560.00
EJ-303	300g x 0.001g	4.3"	4 lb	7624	620.00
EJ-120	120g x 0.01g	4.3"	4 lb	7540	305.00
EJ-200	200g x 0.01g	4.3"	4 lb	7541	380.00
EJ-300	300g x 0.01g	4.3"	4 lb	7542	450.00
EJ-410	410g x 0.01g	4.3"	4 lb	7543	490.00
EJ-610	610g x 0.01g	4.3"	4 lb	7544	625.00
EJ-1202	1,200g x 0.01g	5" x 5.5"	6 lb	7671	665.00
EJ-3002	3,100g x 0.01g	5" x 5.5"	6 lb	7672	715.00
EJ-1500	1500g x 0.1g	5" x 5.5"	6 lb	7545	305.00
EJ-2000	2100g x 0.1g	5" x 5.5"	6 lb	7546	370.00
EJ-3000	3100g x 0.1g	5" x 5.5"	6 lb	7547	455.00
EJ-4100	4100g x 0.1g	5" x 5.5"	6 lb	7548	510.00
EJ-6100	6100g x 0.1g	5" x 5.5"	6 lb	7549	580.00

Options

EJ-02C USB interface w/ cable	1 lb	7550	105.00
EJ-03C RS232 interface w/ cable	1 lb	7551	95.00
EJ-07 Underhook for EJ 3K, 4.1K, 6.1K	1 lb	7552	80.00
EJ-08 Underhook for EJ 1500 and 2000	1 lb	7553	80.00
EJ-11 Breeze break	1 lb	7554	80.00
EJ-12 Carry case	1 lb	7555	75.00
EJ-13 Density determination kit	1 lb	7556	95.00

Service Parts

TB:662 adapter 120 VAC	1 lb	1305	45.00
06:4011084B-2 foot EK EW EJ	1 lb	6176	10.00



A&D WEIGHING DIVISION

EK-G Bench Scale

Service Parts only for A&D EK-G.

Part Number	Weight	SKU	List
Service parts			
TB:102 AC adapter 120 VAC for EW/EK	1 lb	986	\$ 45.00
TB:119 AC adapter 220 VAC for EW/EK	1 lb	674	55.00
08:3000113 Keysheet for EK-G	1 lb	3138	28.00
SK:SKHHAK Pushbutton switch individual	1 lb	3139	10.00
07:3001151 Protective covers for EW/EK	1 lb	3140	15.00



A&D WEIGHING DIVISION

SK Bench Scale

1/2,000 resolution, solid & reliable design, splash proof (driptight), large & clear LCD display 25mm high, large stainless steel pan. Portable with (6) D size batteries (not included). Indicators for Stable, Net, Zero and Low battery. Keys for ON/OFF, ZERO, TARE. Auto power off function. SK-Z is LB w/decimal oz, fractional oz, decimal lb. Optional AC adapter (not included). 244mm x 232mm x 137mm.

USDA Approved

NTEP Legal for Trade 98-086 Class III, CSA

Part Number	Capacity	Pan	Weight	SKU	List
Dual Display					
SK-5000D	11 lb x 0.005 lb	230 x 190mm	9 lb	5541	330.00

Options

TB:662 AC adapter 120 VAC 1 lb 1305 45.00

FV-06 AC adapter 220 VAC 1 lb 1306 55.00

Service Parts

PZ:3006 main board for SK (specify capacity) 1 lb 3251 100.00

07:4003338 plastic foot 1 lb 3269 10.00

08:4003781 keysheet 1 lb 3270 6.00



**SK-5001+
Bench Scale**



A&D WEIGHING DIVISION

SJ Bench Scale

Bright and Multi-Colored 5-Step LED Comparator Lights Externally mounted load cell to realize fast stabilization (0.5 seconds), IP67 Dust and Waterproof Construction, Large LCD digits (26 mm height) with white backlight that provides excellent visibility in dim light, Unparalleled, 5000-hour continuous operation with normal batteries, Key lock function to prevent operators from making unwanted changes to the scale settings, Auto power OFF function to avoid wasting power when the scale is inactive for a set period (5 to 60 minutes) of time, Four selectable weighing resolutions: 1/3,000, 1/6,000 (or 1/7,500), 1/12,000 (or 1/15,000), and 1/30,000 Multiple weighing units: gram, kilogram, pound, ounce, troy ounce, pound-ounce, tael (Singapore/HK jewelry/Taiwan), tola, and Newton Counting mode to count a number of small pieces of the same weight instantly and precisely, Scratch-free and hygienic stainless steel (SUS304) weighing pan, Removable, transparent pan support with overhanging panels to shield the load cell Waterproof and anti-corrosive load cell with integrated overload protection mechanism, Counting mode function, Auto power OFF function, Battery life indicator

Part Number	Capacity	Weight	SKU	List
SJ-3000WP	6 lb x 0.001 lb	9 lb	2059	560.00
SJ-6000WP	13 lb x 0.002 lb	9 lb	2060	560.00
SJ-15KWP	33 lb x 0.005 lb	9 lb	2061	590.00
SJ-30KWP	66 lb x 0.01 lb	9 lb	2062	585.00

Service Parts

Plastic pan SJ-WP 0.26 lb 2164 22.26

1072002653A battery cover for SJ-WP 0.03 lb 5887 27.85



SJ-WP

Prices are subject to change without notice. Please call for current prices.

Other items are available from the manufacturers, please call for prices.

13-01 Pollitt Dr Ext
Fair Lawn NJ 07410
201-797-2718



www.totalcomp.com
sales@totalcomp.com
Fax 201-797-2287



ABW Aqua Washdown bench

ABW Aqua washdown bench

ABW washdown scales are IP67 rated and feature a large **stainless steel** weighing pan and solid ABS housing. They are protected for water immersion up to one meter deep. The Aqua is suitable for applications that require frequent and repetitive cleaning. Dual displays are front facing and rear facing LED displays 0.8" high. Check weighing has LED color changing indicators which will show if the weight is HI LOW or OK compared to preset limits. Percentage weighing and parts counting function are available for the operator to use. Keys for Power ON/OFF, ZERO, TARE, UNITS. Power is supplied using the included AC adapter or the built in rechargeable battery with 55 hours of continual use. 10"W x 11.4"D x 4.1"H. IP67

Part Number	Capacity	Pan	Weight	SKU	List
ABW4	9 x 0.001 lb	9.6" x 7.1"	5.5 lb	1963	\$ 445.00
ABW8	15 x 0.002 lb	9.6" x 7.1"	5.5 lb	1964	445.00
ABW16	32 x 0.005 lb	9.6" x 7.1"	5.5 lb	1965	445.00
ABW32	70 x 0.01 lb	9.6" x 7.1"	5.5 lb	1966	445.00



LBX Bench/Floor Scale

LBX Component Bench Scale

With intuitive operation, Latitude compact bench scales deliver excellent value for quick, basic weighing, checkweighing, and counting needs. Latitude compact bench scales deliver an excellent value for weighing, checkweighing, percentage weighing, and counting. With easy operation, Latitude is ideal for production, warehouse, or field use, as it is powered by the included AC adapter or internal rechargeable battery. The battery operates for 240 hours, so there are no worries about losing power. For added flexibility and convenience, Latitude can be charged using any USB power source, such as the USB connection in a vehicle or external USB power banks.

Part Number	Capacity	Platform	Weight	SKU	List
LBX 3	6 x 0.001 lb	9.6" x 7.1"	6 lb	517	\$ 290.00
LBX 6	12 x 0.002 lb	9.6" x 7.1"	6 lb	518	290.00
LBX 12	25 x 0.005 lb	9.6" x 7.1"	6 lb	519	290.00
LBX 30	65 x 0.01 lb	9.6" x 7.1"	16 lb	520	290.00



ED Bench Scale

Multi function scale, battery operated. LCD display with backlight. Dual range for improved accuracy. Counting and percentage, accumulation. Comparison HI/OK/LO with alarm beeps. lb/oz/kg/g switchable with front panel key. Soft touch keys for ON/OFF, ZERO, TARE, MODE, PRINT, SAMPLE, *, SET. Indicators for ZERO, NET, STABLE, LOW BATTERY. 170 hour operating time with rechargeable battery, included. Battery saver mode with auto off. A/C adapter, included. 120 VAC. **Stainless Steel** platform size 12" x 8.75". Overall size 13"W x 13"D x 4.2"H. RS232 output for printer. NTEP Legal for Trade 09-072



ED Bench Scale



Part Number	Capacity	Weight	SKU	List
ED-6LB	3x0.001 lb/6x 0.002 lb	13 lb	988	\$ 325.00
ED-15LB	6x0.002 lb/15x0.005 lb	13 lb	989	325.00
ED-30LB	15x0.005 lb/30x0.01 lb	13 lb	990	325.00
ED-60LB	30x0.01 lb/60x0.02 lb	13 lb	991	325.00
Options				
TM-U295 Ticket Printer w/power supply		8 lb	2225	656.00

Prices are subject to change without notice. Please call for current prices.

Other items are available from the manufacturers, please call for prices.



SW-10RS
POS Interface



SW-RS POS Interface Bench Scale

Compact, use where space is limited. Stainless steel platter. Large easy to read 1", 5 digit LCD display. Customer rear display. Soft touch tactile keyboard. Keys for ZERO, TARE, UNIT, POWER. Indicators for Stable, Zero, Net, Batt. Lg, g, kg, switchable. RS-232 interface. DC 9V. AC adapter included. Auto power off. 1 year warranty. 10.23"W x 11.29"D x 5.39"H

NTEP Legal for Trade 99-002 III 2,500 div

Part Number	Capacity	Pan	Weight	SKU	List
SW-10RS	10 x 0.005 lb	9.05" x 7.48"	10 lb	2696	\$ 389.00
SW-20RS	20 x 0.01 lb	9.05" x 7.48"	10 lb	2697	389.00

Options

WS13 Serial cable			1 lb	2215	31.50
-------------------	--	--	------	------	-------

Service Parts

ZS11 Battery Cover			0.25 lb	7616	11.00
TS13 SS tray for SW-10, SW-20, SW-50			0.57 lb	7628	42.80



SW-20Z
Bench scale

SW-Z Bench Scale

The SW-Z features lb:oz displayed as fractions or decimals. 5 digit, 1 inch high LCD display. Keys for ON/OFF, TARE, UNIT, ZERO. Indicators for Stable, Zero, Net, Battery. Dual range technology. (6) D size batteries not included. AC adapter included. 10.2"W x 11.3"D x 5.4"H.

Part Number	Capacity	Pan	Weight	SKU	List
SW-5Z	5 x 0.002 lb	9.05" x 7.48"	10 lb	6349	\$ 199.00
SW-10Z	10 x 0.005 lb	9.05" x 7.48"	10 lb	6351	199.00
SW-20Z	20 x 0.01 lb	9.05" x 7.48"	10 lb	6352	199.00
SW-50Z	50 x 0.02 lb	9.05" x 7.48"	10 lb	6353	199.00

Service Parts

ZS25 battery			2 lb	7508	47.00
TS14 SS tray for SW-5			0.57 lb	7413	42.80
TS13 SS tray for SW-10, SW-20, SW-50			0.57 lb	7628	42.80
TS11 platter, plastic (all capacities)			0.43 lb	7668	29.00



SW Bench Scale

Digital scale, **Stainless Steel** platform, battery operated, lb/kg/g/oz switchable with front panel key. Soft touch keys for ON/OFF, ZERO, TARE, UNIT. Large 1" LCD display. Indicators for ZERO, NET, STABLE, LOW BATTERY. 1,000 hour operating time with (6) D alkaline batteries (not included). Includes A/C adapter 120 VAC, 50/60 Hz, 0.25 watts. Overall size 10.23"W x 11.29"D x 5.39"H.

NTEP Legal for Trade 99-002 III 2,500 div

Part Number	Capacity	Pan	Weight	SKU	List
SW-5	5 lb x 0.002 lb	9.05" x 7.48"	10 lb	1791	\$ 199.00
SW-10	10 lb x 0.005 lb	9.05" x 7.48"	10 lb	1792	199.00
SW-20	20 lb x 0.01 lb	9.05" x 7.48"	10 lb	1793	199.00
SW-50	50 lb x 0.02 lb	9.05" x 7.48"	10 lb	1794	199.00

Options

AC adapter 120 VAC for SW	1 lb	1731	42.85
CS11 In use cover for SW-10, SW-20, SW-50	1 lb	1740	19.00

Service Parts

LS11 load cell SW-5	2kg	1 lb	124	88.00
LS12 load cell SW-10	5kg	1 lb	125	88.00
LS13 load cell SW-20	10kg	1 lb	126	88.00
LS14 load cell SW-50	20kg	1 lb	127	88.00
KS11 keypad for SW	0.04 lb	212	15.00	
ZS11 battery cover	0.25 lb	7616	11.00	
TS14 SS tray for SW-5	0.57 lb	7413	42.80	
TS13 SS tray for SW-10, SW-20, SW-50	0.57 lb	7628	42.80	
TS11 platter, plastic (all capacities)	0.43 lb	7668	29.00	



**SW-20
Bench Scale**



SW-W Washdown Bench Scale

The SW-W is protected from water, dirt and other external agents (IP66). 5 digit, 1 inch high LCD display. Weighing units in: lb, oz, kg, g. Keys for ON/OFF, TARE, UNIT, ZERO. Indicators for Stable, Zero, Net, Battery. Dual range technology. (6) D size batteries not included. AC adapter included.

NTEP Legal for Trade 99-002 III 2,500 div

Part Number	Capacity	Pan	Weight	SKU	List
SW-10W	10 x 0.005 lb	9.75"x7.75"	10 lb	6340	\$ 289.00
SW-20W	20 x 0.01 lb	9.75"x7.75"	10 lb	6341	289.00
SW-50W	50 x 0.02 lb	9.75"x7.75"	10 lb	6342	289.00

Service Parts

ZS11 battery cover	1 lb	7616	11.00
TS13 SS tray for SW-10, SW-20, SW-50	0.57 lb	7628	42.80
TS11 platter, plastic (all capacities)	0.43 lb	7668	29.00



**SW-W
Washdown Bench Scale**



Prices are subject to change without notice. Please call for current prices.

Other items are available from the manufacturers, please call for prices.

13-01 Pollitt Dr Ext
Fair Lawn NJ 07410
201-797-2718

Totalcomp
Scales & Balances

www.totalcomp.com
sales@totalcomp.com
Fax 201-797-2287



**Ranger 3000
Compact Bench Scale**



Ranger 3000 Compact Bench Scale

Ranger 3000 has an ABS housing and a stainless steel platform. Compact basic bench scale with large bright backlit LCD display. Checkweighing LED with 3 colors for over/under/ok. Applications for: weighing, Percent Weighing, Parts Counting, Checkweighing, Checkcounting, Checkpercent, Accumulation, Dynamic Weighing/Display Hold, Weigh below (hook included). Weighing units: lb/kg/g/oz/lb.oz Communication port included RS232, USB or Ethernet available as an option. Powered by AC adapter and battery (included) 210 hours of battery life with continuous use.

NTEP Legal for Trade 13-022A1

Canada AM-5907C

Part Number	Capacity	Pan	Weight	SKU	List
R31P1502	3 x 0.0001 lb	8.9" x 11.8"	12 lb	8016	\$ 860.00
R31P3	6 x 0.0002 lb	8.9" x 11.8"	12 lb	8017	860.00
R31P6	15 x 0.0005 lb	8.9" x 11.8"	12 lb	8018	860.00
R31P15	30 x 0.001 lb	8.9" x 11.8"	12 lb	8019	860.00
R31P30	60 x 0.002 lb	8.9" x 11.8"	12 lb	8020	860.00

Options

30037447 Ethernet kit	1 lb	7968	204.00
30037448 RS232 kit	1 lb	7969	204.00
30037449 USB kit	1 lb	3819	204.00
30064203 SF40A Dot Matrix printer, includes RS232 cable	2 lb	1754	1,303.00
80500525 Cable to IBM 9 pin serial	1 lb	3047	254.00
80850080 WinWedge software	1 lb	2436	702.00
71168359 battery pack	3 lb	6506	94.00
7220232 line cord	1 lb	6507	32.00



SPX STX Scout Portable Bench Scale

Setting new standards in laboratory and industrial weighing. Bright Backlit LCD. Keys for: ZERO/PRINT/UNITS/FUNCTION/MODE/TARE/MENU. Weighing Units for: g, kg, ct, N, oz, ozt, dwt, lb, ln:oz, grn. Application modes: Weighing, Parts Counting, Percent Weighing, Check Weighing, Totalization, Display Hold. Draft shield. Weigh below hook. Lockswitch. Security slot. Connectivity. RS232, USB host, USB device, Ethernet. AC adapter (included) or (4) AA batteries (not included). 11.8" x 9.8" x 4.1" (SPX123/SPX223) 11.8" x 9.8" x 3.4" (SPX222, 422, 622, 1202, 2202, 421, 621, 2201, 6201, 8200). 2 year warranty.

Part Number	Capacity	Pan	Weight	SKU	List
Push Button					
SPX123	120 x 0.001g	3.7"	4 lb	8173	\$ 889.00
SPX223	220 x 0.001g	3.7"	4 lb	8174	993.00
SPX222	220 x 0.01g	4.7"	4 lb	8175	647.00
SPX422	420 x 0.01g	4.7"	4 lb	8176	907.00
SPX622	620 x 0.01g	4.7"	4 lb	8177	1,063.00
SPX1202	1,200 x 0.01g	6.7" x 5.5"	4 lb	8178	1,213.00
SPX2202	2,200 x 0.01g	6.7" x 5.5"	4 lb	8179	1,363.00
SPX421	420 x 0.1g	4.7"	4 lb	8180	357.00
SPX621	620 x 0.1g	6.7" x 5.5"	4 lb	8181	528.00
SPX2201	2,200 x 0.1g	6.7" x 5.5"	4 lb	8182	676.00
SPX6201	6,200 x 0.1g	6.7" x 5.5"	4 lb	8183	1,103.00
SPX8200	8,200 x 1g	6.7" x 5.5"	4 lb	8184	552.00
Touch Screen					
STX123	120 x 0.001g	3.7"	4 lb	8185	1,010.00
STX223	220 x 0.001g	3.7"	4 lb	8186	1,132.00
STX222	220 x 0.01g	4.7"	4 lb	8187	745.00
STX422	420 x 0.01g	4.7"	4 lb	8188	1,040.00
STX622	620 x 0.01g	4.7"	4 lb	8189	1,218.00
STX1202	1,200 x 0.01g	6.7" x 5.5"	4 lb	8190	1,391.00
STX2202	2,200 x 0.01g	6.7" x 5.5"	4 lb	8191	1,553.00
STX421	420 x 0.1g	4.7"	4 lb	8192	421.00
STX621	620 x 0.1g	6.7" x 5.5"	4 lb	8193	630.00
STX2201	2,200 x 0.1g	6.7" x 5.5"	4 lb	8194	797.00
STX6201	6,200 x 0.1g	6.7" x 5.5"	4 lb	8195	1,259.00
STX8200	8,200 x 1g	6.7" x 5.5"	4 lb	8196	652.00
Options					
30269021 carry case			1 lb	1988	172.00
30268988 stacking kit storage cover			1 lb	1969	31.00
Service Parts					
30330714 AC adapter w/plug SPX/STX			1 lb	2740	35.00
30268984 USB device interface			1 lb	5325	154.00
30268982 RS232			1 lb	1675	220.00
30301950 foot adjustable, pack(4)			1 lb	1034	28.00
71160302 top housing SP202			1 lb	6058	46.00
71160346 function label SP202			1 lb	6059	34.00
83033644 SP pan support, rect pan set of (4)			0.03 lb	6014	48.00



**SPX
Push Button
Portable Bench Scale**



**STX
Touch Screen
Portable Bench Scale**

Prices are subject to change without notice. Please call for current prices.

Other items are available from the manufacturers, please call for prices.



**Ranger 4000
Bench Scale**



OHAUS®

Ranger 4000 Bench Scale

Portable with die-cast metal housing with slip-resistant rubber feet and a rechargable lead acid battery that can provide power for up to 100 hours. A bright LED display makes the scale usable even in dim conditions. SmartText software makes scale setup and use very simple. Standard RS232 with optional Ethernet, second RS232 and USB offers additional data transfer capabilities and allows connection to multiple peripherals. Stabilization time of just one second. 12.4"Wx12.9"Lx4.8"H.

NTEP Legal for Trade 13-022 III 3,000 div

Part Number	Capacity	Pan	Weight	SKU	List
R41ME3	6 x 0.0002 lb	8.9 x 11.8"	17 lb	1742	\$ 1,230.00
R41ME6	15 x 0.0005 lb	8.9 x 11.8"	17 lb	1743	1,230.00
R41ME15	30 x 0.001 lb	8.9 x 11.8"	17 lb	1744	1,230.00
R41ME30	60 x 0.002 lb	8.9 x 11.8"	17 lb	1745	1,230.00

Options

30037447 Ethernet kit	1 lb	7968	204.00
30037448 RS232 kit	1 lb	7969	204.00
30037449 USB kit	1 lb	3819	204.00
30064203 SF40A Dot Matrix printer, includes RS232 cable	2 lb	1754	1,303.00
80500525 Cable to IBM 9 pin serial	1 lb	3047	254.00
80850080 WinWedge software	1 lb	2436	702.00

OHAUS®

Ranger 7000 Compact Bench Scale

Ranger 7000 has a die-cast sealed metal indicator and housing, ensuring it's accurate and long term operation in even the most demanding industrial environments. Stainless steel platform. 4.3" TFT graphic LCD. 8 function, 5 quick, 12 alphanumeric membrane keys. SmartText 2.0 software. Advanced application modes for a variety of complex applications which minimize the need for manual calculations. Applications for: Weighing, Density Determination, Filling, Differential Weighing, Parts Counting, Dynamic Weighing, Formulation, Check Weighing/Counting, Percent Weighing. Weighing units are: kg, g, lb, oz, lb:oz. Weigh hook below. Easily export data through RS232 or USB device port. Additional connectivity options include a second RS232 or Ethernet, and USB host port for bar code scanner or flash drive. Remote base kit, 2 in/4 out digital I/O kit. 100-240 VAC 50/60 Hz Universal Power Supply.

NTEP Legal for Trade 14-033 II and III

Canada AM 5940



**7000
Compact Bench Scale**



Part Number	Capacity	Pan	Weight	SKU	List
R71MD3	6 x 0.0001 lb	11" x 11" x 4.5"	28 lb	7960	\$ 2,455.00
R71MD6	15 x 0.0002 lb	11" x 11" x 4.5"	28 lb	7961	2,455.00
R71MD15	30 x 0.0005 lb	14.8" x 12.2" x 1.9"	29 lb	7962	2,455.00
R71MD35	70 x 0.001 lb	14.8" x 12.2" x 1.9"	29 lb	7963	2,455.00
R71MD60	150 x 0.002 lb	14.8" x 12.2" x 1.9"	29 lb	7343	2,455.00
R71MHD3	6 x 0.00002 lb	11" x 11" x 4.5"	28 lb	7964	3,895.00
R71MHD6	15 x 0.00005 lb	11" x 11" x 4.5"	28 lb	7965	4,325.00
R71MHD15	30 x 0.0002 lb	14.8" x 12.2" x 1.9"	29 lb	7966	5,720.00
R71MHD35	70 x 0.002 lb	14.8" x 12.2" x 1.9"	29 lb	7967	6,895.00

Options

30037447 Ethernet kit	1 lb	7968	204.00
30037448 RS232 kit	1 lb	7969	204.00
30095408 Column kit painted	5 lb	7970	204.00
30097590 PCBA kit 2nd platform	1 lb	7971	205.00
30097591 Discrete I/O Kit 2in/4 out	1 lb	7972	204.00
30101495 Cable extension, 9 meter	2 lb	7973	145.00

Service Parts

30041267 AC linecord Ranger 7000	1 lb	4963	60.00
----------------------------------	------	------	-------

Prices are subject to change without notice. Please call for current prices.

Other items are available from the manufacturers, please call for prices.



Valor 1000 Bench Scale

Service parts only.

Part Number	Capacity	Pan	Weight	SKU	List
Service Parts					
46001812 AC adapter Valor 1000			1 lb	4974	82.00
80252845 function label keypad			1 lb	4883	29.00
30035606 Feet Kit			1 lb	4838	30.00
71172939 foot(4)			1 lb	4895	40.00
71172940 pan support cap(4)			1 lb	4896	51.00



**Valor 1000
Bench Scale**



Valor 2000 Bench Scale

Valor 2000 has a ABS housing with a stainless steel platform. Also available with a stainless steel top housing. Compact water resistant bench scale with a red LED 0.8" high dual display and a polycarbonate knife proof keypad. Applications: Weighing and checkweighing. Weighing units g, kg, lb, lb:oz. Powered by AC adapter and internal battery with 50 hours of battery life for continuous use. 10.1"W x 11.3"D x 4.9"H.



Valor 2000
Bench Scale

Part Number	Capacity	Pan	Weight	SKU	List
Stainless Steel w/checkweighing					
V22XWE1501T	3 x 0.0005 lb	7.5" x 9.5"	11 lb	8311	\$ 695.00
V22XWE3T	6 x 0.001 lb	7.5" x 9.5"	11 lb	8312	695.00
V22XWE6T	15 x 0.002 lb	7.5" x 9.5"	11 lb	8313	695.00
V22XWE15T	30 x 0.005 lb	7.5" x 9.5"	11 lb	8314	695.00
V22XWE30T	60 x 0.01 lb	7.5" x 9.5"	11 lb	8315	695.00
ABS housing w/stainless steel pan					
V22PWE1501T	3 x 0.0005 lb	7.5" x 9.5"	9 lb	8316	610.00
V22PWE3T	6 x 0.001 lb	7.5" x 9.5"	9 lb	8317	610.00
V22PWE6T	15 x 0.002 lb	7.5" x 9.5"	9 lb	8318	610.00
V22PWE15T	30 x 0.005 lb	7.5" x 9.5"	9 lb	8319	610.00
V22PWE30T	60 x 0.01 lb	7.5" x 9.5"	9 lb	8320	610.00



Valor 3000 Xtreme Bench Scale

T304 stainless steel housing. Chemical resistant, durable and easy to clean, technically advanced overload protection rated at 10x capacity. Quadrastance design, adjustable rubber feet ensures firm contact with bench top. SmartText user interface, bright backlit LCD. Weighing modes are: lb, dec/oz, lb:oz, fractional oz, g, kg, fl/oz. User selectable and lockable. AC adapter included or (4) C batteries (not included), NSF listed warranty 120 VAC, USDA approved, supports HACCP systems. NEMA 4X/IP65 water resistant models. 2 year warranty. 8.5"W x 7.3"D x 3".H
NTEP Legal for Trade 08-008 III 3,000 div



Valor 3000
Bench Scale



Part Number	Capacity	Pan	NTEP	Weight	SKU	List
V31XH202 compact	200 x 0.01g	4.7" dia	----	5 lb	4761	\$ 995.00
V31XH402 compact	400 x 0.01g	5.8" x 6.2"	----	5 lb	5465	1,385.00
V31X501compact	500 x 0.1g	4.7" dia	----	5 lb	5464	770.00
V31XH2 compact	2,000 x 0.1g	5.8" x 6.2"	----	5 lb	4762	965.00
V31X3 compact	3,000 x 1g	5.8" x 6.2"	----	5 lb	4763	675.00
V31XH4 compact	4,000 x 0.1g	5.8" x 6.2"	----	5 lb	5466	1,385.00
V31X3N compact *	3,000 x 0.5g	5.8" x 6.2"	3,000x1g	5 lb	4897	775.00
V31X6 compact	6,000 x 1g	5.8" x 6.2"	----	5 lb	4764	675.00
V31X6N compact *	6,000 x 1g	5.8" x 6.2"	6,000x2g	5 lb	4898	775.00

Washdown

V31XW301 washdown	300 x 0.1g	5.8" x 6.2"	----	5 lb	4765	775.00
V31XW3 * washdown	3,000 x 0.5g	5.8" x 6.2"	3,000x1g	5 lb	4766	775.00
V31XW6 * washdown	6,000 x 1g	5.8" x 6.2"	6,000x2g	5 lb	4767	775.00

* NTEP Legal for Trade

Options

80250400 Stainless steel scoop	2 lb	2025	98.00
80250954 Stainless steel scoop	8 lb	5274	109.00

Service Parts

46001803 AC adapter Valor 3000	1 lb	4992	80.00
72203363 load cell 10kg V31	1 lb	4891	218.00

Prices are subject to change without notice. Please call for current prices.

Other items are available from the manufacturers, please call for prices.



Valor 4000 Bench Scale

Easy to clean, easy to transport. 6 digit, 7 segment 0.8" large dual red LED display. Keys for ON/OFF/ZERO, M+/UNITS, FUNCTION/MODE, TARE/MENU. Applications for Weighing, Percent Weighing, Checkweighing, Accumulation. Touchless sensor for Tare function. Fixed weighing pan. Overload and underload indicators. Less than 0.5s stabilization time. Low battery indicator. Level bubble. Power jack auto enclosed design. Rechargeable battery. AC adapter. IPX8. 2 year warranty. 16.1"W x 14.6"D x 8.7"H. NTEP Legal for Trade 13-056 III 3,000 div Canada AM-5906C



Valor 4000 Bench Scale

Part Number	Capacity	Pan	Weight	SKU	List
V41PW: ABS housing with 304 Stainless Steel platform.					
V41PWE1501T	1.5 kg x 0.5 g	7.5" x 9.5"	4 lb	7974	\$ 655.00
V41PWE3T	3 kg x 1 g	7.5" x 9.5"	4 lb	7975	655.00
V41PWE6T	6 kg x 2 g	7.5" x 9.5"	4 lb	7976	655.00
V41PWE15T	15 kg x 5 g	7.5" x 9.5"	4 lb	7977	655.00
V41XW: Stainless Steel housing and platform.					
V41XWE1501T	1.5 kg x 0.5 g	7.5" x 9.5"	10 lb	7978	770.00
V41XWE3T	3 kg x 1 g	7.5" x 9.5"	10 lb	7979	770.00
V41XWE6T	6 kg x 2 g	7.5" x 9.5"	10 lb	7980	770.00
V41XWE15T	15 kg x 5 g	7.5" x 9.5"	10 lb	7981	770.00

Service Parts

46001802 AC adapter 120 VAC w/o prong set	1 lb	716	82.00
46001780 Prong set, International	1 lb	714	29.00
46001776 Prong set, US only	1 lb	6226	29.00
30272114 SP Mech 4 way module	1 lb	7590	36.00
30028582 function label	1 lb	7153	30.00





**Valor 7000
Bench Scale**



Valor 7000 Bench Scale

Stainless steel, removable weighing platform. ABS housing. Touchless sensors located in the front and rear allow you to do all of your weighing without ever touching the scale. Dual backlit displays; 1.5" front and 1" rear display are both equipped with an LCD backlight for added clarity. Keys for ON/ZERO/OFF, PRINT/UNITS, FUNCTION/MODE, M+/MENU, TARE. Weighing units for lb, oz, lb:oz, g. Application modes for Weighing, Check Weighing, Check Percent, Percent Weighing, Accumulation. Rapid stabilization. Non-slip grip. Carry handle. Rechargeable lead acid battery that can provide power for more than 210 hours between charges. IP43. 2 year warranty. 15.6"W x 17.6"D x 7.7"H. NTEP Legal for Trade 13-022 III 3,000 div
Canada AM-5907C

Part Number	Capacity	Pan	Weight	SKU	List
V71P1502T	3 x 0.0001 lb	11.8" x 8.9"	12 lb	3814	\$ 899.00
V71P3T	6 x 0.0002 lb	11.8" x 8.9"	12 lb	3815	899.00
V71P6T	15 x 0.0005 lb	11.8" x 8.9"	12 lb	3816	899.00
V71P15T	30 x 0.001 lb	11.8" x 8.9"	12 lb	3817	899.00
V71P30T	60 x 0.001 lb	11.8" x 8.9"	12 lb	3818	899.00

Options

30037447 Ethernet kit	1 lb	7968	204.00
30037448 RS232 kit	1 lb	7969	204.00
30037449 USB kit	1 lb	3819	204.00
30064203 SF40A Dot Matrix printer, includes RS232 cable	2 lb	1754	1,303.00

Service Parts

30037417 Platter	1 lb	7598	55.00
30037421 Foot, pack(4)	1 lb	7713	30.00



TVD Bench Multifunction Scale

Simple one touch weigh and count functions. 0.9 inch LCD display with backlight. Indicator has rugged ABS housing. Applications for Weighing, Counting, Check Weighing, Percent weighing and Accumulation. Keys for ZERO/ON/OFF, TARE, UNIT, PRINT/HOLD. Units: lb, ounce, kg, grams. 9 volt battery operated with power adapter included. Standard USB interface can be connected to computer for receiving weight data. Overall 12.6" W x 13.7" D x 3.96" H.

NTEP Legal for Trade

Part Number	Capacity	Platform	Weight	SKU	List
TVD-6	6 lb x 0.001 lb 3 kg x 0.0005 kg 96 oz x 0.02 oz	9 x 12"	11 lb	951	\$ 286.00
TVD-12	12 lb x 0.002 lb 6 kg x 0.001 kg 192 oz x 0.05 oz	9 x 12"	11 lb	952	286.00
TVD-30	30 lb x 0.005 lb 12 kg x 0.002 kg 480 oz x 0.1 oz	9 x 12"	11 lb	953	286.00
TVD-60	60 lb x 0.01 lb 30 kg x 0.005 kg 960 oz x 0.2 oz	9 x 12"	11 lb	954	286.00



TVD Bench Scale

Prices are subject to change without notice. Please call for current prices.

Other items are available from the manufacturers, please call for prices.



BCS40
Portable Brief Case scale

BCS Brief Case Scale

9" x 9" cast platform with indicator in a briefcase. Weighing units: lb, kg, lb-oz, g. Large high contrast LCD display. Low battery indicator. Keys for ON/OFF, TARE, UNITS. (1) 9V battery (included). Case dimensions 11"L x 13"W x 2.5"H.

Part Number	Capacity	Weight	SKU	List
BCS-40 briefcase	40 kg x 10 g 88 lb x 0.02 lb	9 lb	6015	\$ 287.82
BCS-80 briefcase	80 kg x 20 g 176 lb x 0.05 lb	9 lb	6016	287.82



A&D WEIGHING DIVISION

HV Bench Scale

Waterproof and dustproof, IP-65 rating. Stainless steel construction.. Triple range on HV series. Comparator function for high and low set points with HI/OK/LO on display. GLP/GMP/ISO Compliant. CP models include built-in printer. The 10-digit alphanumeric keypad simplifies setting comparator limits.
NTEP Legal for Trade 90-064A2

Part Number	Capacity	Pan	Weight	SKU	List
Multi Capacity Bench Scale					
HV-15KC	6 x 0.002 lb 15 x 0.005 lb 30 x 0.001 lb	9.8"x9.8"	13 lb	2571	\$ 1,050.00
HV-60KC	30 x 0.01 lb 60 x 0.02 lb 150 x 0.05 lb	13.0"x16.7"	24 lb	2572	1,050.00
HV-200KC	150 x 0.05 lb 300 x 0.1 lb 500 x 0.2 lb	15.4"x20.9"	37 lb	2573	1,320.00
Printer built into indicator					
HV-15KCP	6 x 0.002 lb 15 x 0.005 lb 30 x 0.01 lb	9.8"x9.8"	13 lb	2578	1,690.00
HV-60KCP	30 x 0.01 lb 60 x 0.02 lb 150 x 0.05 lb	13.0"x16.7"	24 lb	2579	1,760.00
HV-200KCP	150 x 0.05 lb 300 x 0.1 lb 500 x 0.2 lb	15.4"x20.9"	37 lb	2580	1,920.00
High Resolution Single Range					
HW-10KC	20 x 0.002 lb	9.8"x9.8"	13 lb	2574	1,150.00
HW-60KC	150 x 0.01 lb	13.0"x16.7"	24 lb	2575	1,300.00
HW-100KC	200 x 0.02 lb	15.4"x20.9"	37 lb	2576	1,360.00
HW-200KC	500 x 0.05 lb	15.4"x20.9"	37 lb	2577	1,450.00
Printer built into indicator					
HW-10KCP	20 x 0.02 lb	9.8"x9.8"	13 lb	2581	1,790.00
HW-60KCP	150 x 0.01 lb	13.0"x16.7"	24 lb	2582	1,950.00
HW-100KCP	200 x 0.02 lb	15.4"x20.9"	37 lb	2583	2,040.00
HW-200KCP	500 x 0.05 lb	15.4"x20.9"	37 lb	2584	2,105.00
Service parts					
ED:HT4096A-TI LCD display HVG HWG AD-4406			1 lb	1303	49.00



HV-15KC



LC:127 A&D

Replacement for HV HWG
1 mv/v, 350/350 ohms, 1.5m 4 cond cable, anodized aluminum.

Part Number	Scale	Capacity	Weight	SKU	List
LC:127-60K	HV-60KWP	2 kg	2 lb	6063	\$ 253.00



LC:1271

Prices are subject to change without notice. Please call for current prices.

Other items are available from the manufacturers, please call for prices.

13-01 Pollitt Dr Ext
Fair Lawn NJ 07410
201-797-2718



www.totalcomp.com
sales@totalcomp.com
Fax 201-797-2287



A&D WEIGHING DIVISION



HW-10KGV
Bench/Floor



HW-G Bench Scale

Reliable and rugged. Outstanding price performance. Indicator head tilts and rotates on the column to adjust for the best viewing angle. Standard RS232 interface. Counting and % function. M+ function for totaling weighing data. Front panel keys for ON/OFF, ZERO, TARE, F, SET, SAMPLE, MODE, PRINT. HV models have automatic triple range. VFD (Vacuum Fluorescent Display) work on AC adapter only. Sealed to IP65.

NTEP Legal for Trade 00-088 III 3,000 div (HV series)

Canadian W&M approval AM-5404 on HV-V and HV-L.

Part Number	Capacity	Platform	Weight	SKU	List
VFD Vacuum Fluorescent Display					
HW-10KGV	20 x 0.002 lb	9.8" x 9.8"	16 lb	4462	\$ 885.00
HW-100KGV	200 x 0.02 lb	15.4" x 20.9"	40 lb	4464	885.00

Options

TB:662 AC adapter 120 VAC	1 lb	1305	45.00
FV-06 AC adapter 220 VAC	1 lb	1306	55.00

Service Parts

PZ:2755-LCD Main board w/display for HV-GL	1 lb	3125	219.00
PZ:3414 main board HV-GV HW-GV	1 lb	5964	337.00
10:DH-26-1-AD Battery Holder for HV HW	1 lb	3128	15.00
AX:00A34062 Plastic cover for display pod HV HW	1 lb	1307	15.00

*Continued on page 23



LC:4102

LC:4102 & LC:4103 A&D

Replacement for A&D Model HV & HW (FV & FW) (AP & APX)

1 mv/v, 400/350 ohms, 1.5m (4102)/2m (4103) 4 cond cable, anodized aluminum, IP67

Part Number	Scale	Capacity	Weight	SKU	List
Load cells for HV					
LC:4102-K030	HV-30KA2	30 kg	2 lb	341	\$ 295.00
LC:4102-K060	HV-60KA2	60 kg	2 lb	342	305.00
LC:4103-K060	HV-60KA1	60 kg	3 lb	343	360.00
LC:4103-K150	HV-120KA1	150 kg	4 lb	345	370.00
Load cells for HW					
LC:4102-K010	HW-10KA2	10 kg	2 lb	339	320.00
LC:4102-K015	HW-15KA2	15 kg	2 lb	340	320.00
LC:4102-K030	HW-30KA2	30 kg	2 lb	341	295.00
LC:4102-K060	HW-60KA2	60 kg	2 lb	342	305.00
LC:4103-K100	HW-100KA1	100 kg	3 lb	344	360.00
LC:4103-K150	HW-150KA1	150 kg	4 lb	345	370.00



A&D WEIGHING DIVISION

HV-WP Washdown SS Bench Scale

Waterproof and dustproof, NEMA 4 IP-65 rating. Stainless steel construction. Triple range on HV series. Preset tare values can be digitally stored. Comparator function for high and low set points with HI/OK/LO on display. Optional comparator output sounds buzzer. High visibility VFD Vacuum fluorescent Display. Displays weight in lb, kg or piece count. Front panel keys for ZERO, TARE, SET, RANGE, MODE, PRINT, ON/OFF. Drip proof design for easy cleaning with water. 120 VAC.

Canadian approval AM-5404 (HV series)

NTEP Legal for Trade 00-088 III 3,000 div (HV series)

Part Number	Capacity	Platform	Weight	SKU	List
HV-200KWP	150 x 0.05 lb	15.4" x 20.9"	42 lb	4497	\$ 1,615.00
	300 x 0.1 lb				
	500 x 0.2 lb				

Options

HVWP-03 RS232, Comp/Setpoint output(relays & audio)	1 lb	4502	190.00
HVWP-04 RS422/485, Comparator/Setpoint output(relays)	1 lb	4503	175.00

Service Parts

PZ:3414 main board HV-WD HW-WP	1 lb	5964	337.00
707:A21456 swivel head bracket	1 lb	1992	103.00
PZ:3415 power relay board	1 lb	1402	53.00



HV-15KWP
Bench/Floor



HV-G HW-G Bench/Floor Scale-Service Parts

Service Parts for HV-G HW-G

Part Number	Weight	SKU	List
Service Parts			
LC:126-15K load cell SB15K10	2 lb	4938	199.00
LC:128-220K load cell HVG HWG HVWP HWWP	2 lb	4724	295.00
03:1000077A pole base large	1.68 lb	4781	50.00
10:A46050-2 swivel head bracket cap	1 lb	4754	10.00
07:1000097A upper case	1 lb	4755	15.00
07:1000098 lower case	1 lb	4757	20.00
07:2000417 battery cover	1 lb	4758	10.00
07:1000099 battery case	1 lb	4759	10.00
07:3003185 battery holder	1 lb	4760	10.00
07:3003186 HV-G/HW-G rear cover	1 lb	1399	10.00
08:4007481-4B HV-GL Display filter	1 lb	1297	14.00
08:4007463 HV-GL keysheet	1 lb	1298	19.00
08:3003337-9 HV-60KG capacity label (Non-NTEP)	1 lb	1299	10.00
08:4007465 HV-60KGL model label	1 lb	1300	10.00
PZ:3413 HV-GL/HW-GL main board w/display	1 lb	1301	307.00



HV-200KWP
Bench/Floor

Prices are subject to change without notice. Please call for current prices.

Other items are available from the manufacturers, please call for prices.

13-01 Pollitt Dr Ext
Fair Lawn NJ 07410
201-797-2718

Totalcomp
Scales & Balances

www.totalcomp.com
sales@totalcomp.com
Fax 201-797-2287



A&D WEIGHING DIVISION



FG-K
Bench/Floor
w/ column



FG-K
Bench/Floor
w/o column

FG Bench scale

Self contained, battery operated (6)AA batteries (not included) and AC adapter (included). Approximately 100 hours with alkaline type cells. Full capacity push button tare. Switch selectable pound or kilogram display. All models can be wall or tower mounted. Rugged, durable and portable. 120 VAC, 50/60 Hz, 1.5 watts. Accuracy +/-1 div. 1 Year warranty. Canadian Weights & Measures AM-4995
USDA Approved
NTEP Legal for Trade 93-063 III 3,000 div.

Part Number	Capacity	Pan	Weight	SKU	List
No Column					
FG-30KBMN	60 x 0.02 lb	11.8" x 15"	27 lb	3587	\$ 710.00
FG-60KBMN	150 x 0.05 lb	11.8" x 15"	27 lb	3588	720.00
FG-150KBMN	300 x 0.1 lb	11.8" x 15"	27 lb	3589	770.00
With Column					
FG-30KAMN	60 x 0.02 lb	11.8" x 15"	31 lb	5826	740.00
FG-60KAMN	150 x 0.05 lb	11.8" x 15"	31 lb	5827	750.00
FG-150KAMN	300 x 0.1 lb	11.8" x 15"	31 lb	5828	860.00
FG-60KALN	150 x 0.05 lb	15.4" x 20.9"	43 lb	5829	840.00
FG-150KALN	300 x 0.1 lb	15.4" x 20.9"	43 lb	5830	920.00
FG-200KALN	400 x 0.1 lb	15.4" x 20.9"	43 lb	932	980.00
Options					
FG-23 RS232 FG-N			1 lb	3592	82.00
FG-24 Comparator / Setpoints relay outputs			4 lb	3593	112.00
FG-25 Display wall mount bracket for FG-N			1 lb	3590	94.00
FG-26 Carrying handle for FG-N			1 lb	3595	125.00
Service Parts (for new style FGN)					
PZ:4340 main board w/ display			1 lb	504	323.00
07:3007527A plastic display cover			1 lb	505	16.00
08:2000992A keysheet			1 lb	508	19.00
07:3007273 leveling foot			1 lb	509	20.00
02:4015536 column FGKAL			2 lb	506	85.00
1024015534 column FGKAM			2 lb	507	65.00
707:A21500 swivel head bracket			1 lb	514	82.00
07:A21456 indicator support FG HV HW			5 lb	780	15.20
07:3007280A battery cover FGK			1 lb	795	10.00
LC:150-60K load cell KBM,KAM,KAL			1.04 lb	764	295.00
TB:662 AC adapter 120 VAC			1 lb	1305	45.00
FV-06 AC adapter 240VAC			1 lb	1306	55.00
Service Parts (for old style w/o suffix N)					
01:B30082A keysheet for FG S/N prefix H			1 lb	2775	19.00
07:B49929 leveling foot for FG			1 lb	6180	14.00
Options (for old style w/o suffix N)					
FG-03 RS232 for FG			1 lb	3592	82.00



A&D WEIGHING DIVISION

SE Washdown Scale

Washdown construction for easy cleaning. Mild steel construction. Stainless steel weighing pan. IP68 dust and water proof. Waterproof and corrosion resistant load cell. Supersized LCD of 39 mm character height. Multiple weighing units for kg, lb, oz, pcs. 4500 hours of battery life. Stabilization of 1 second. Quick USB interface or RS232C+ comparator relay output available as options. 2 year warranty.

Part Number	Capacity	Pan	Weight	SKU	List
SE-30KAM	66 x 0.01 lb	11.8" x 15"	32 lb	5484	\$ 1,140.00
SE-60KAM	130 x 0.02 lb	11.8" x 15"	32 lb	5485	1,150.00
SE-150KAM	330 x 0.05 lb	11.8" x 15"	32 lb	5487	1,250.00
SE-60KAL	130 x 0.02 lb	15.4" x 20.9"	46 lb	5488	1,220.00
SE-150KAL	330 x 0.05 lb	15.4" x 20.9"	46 lb	5489	1,280.00

Options

SCE-02 Quick USB Interface	1 lb	3486	180.00
SCE-03 RS232C interface + comparator	1 lb	3488	220.00

Note: SCE-02 and SCE-03 cannot be used at the same time. With either options installed the scale is not IP68 compliant.



**SE Washdown Scale
Mild steel**



A&D WEIGHING DIVISION

SC Washdown Scale

Washdown construction for easy cleaning. Stainless steel construction. Stainless steel weighing pan. IP68 dust and water proof. Waterproof and corrosion resistant load cell. Supersized LCD of 39 mm character height. Multiple weighing units for kg, lb, oz, pcs. 4500 hours of battery life. Stabilization of 1 second. Quick USB interface or RS232C+ comparator relay output available as options. 2 year warranty.

Part Number	Capacity	Pan	Weight	SKU	List
SC-30KAM	66 x 0.01 lb	11.8" x 15"	34 lb	3490	\$ 1,690.00
SC-60KAM	130 x 0.02 lb	11.8" x 15"	34 lb	3491	1,750.00
SC-150KAM	330 x 0.05 lb	11.8" x 15"	34 lb	3493	1,780.00
SC-60KAL	130 x 0.02 lb	15.4" x 20.9"	45 lb	3494	1,820.00
SC-150KAL	330 x 0.05 lb	15.4" x 20.9"	45 lb	3495	1,850.00

Options

SCE-02 Quick USB Interface	1 lb	3486	180.00
SCE-03 RS232C interface + comparator	1 lb	3488	220.00

Note: SCE-02 and SCE-03 cannot be used at the same time. With either options installed the scale is not IP68 compliant.



**SC Washdown Scale
Stainless steel**

Prices are subject to change without notice. Please call for current prices.

Other items are available from the manufacturers, please call for prices.

13-01 Pollitt Dr Ext
Fair Lawn NJ 07410
201-797-2718



www.totalcomp.com
sales@totalcomp.com
Fax 201-797-2287



A&D WEIGHING DIVISION



SW Washdown Scale

SW High Pressure Washdown Scale

Stainless steel. IP69k, the highest level of dust and water proofing. Streamlined construction for easy cleaning of food processing residues. Capacitive keys for light touch operation. Bright, multicolored LED display with 5 level comparator lamps. Rugged and adjustable indicator bracket. Ultimate protection against condensation.

Part Number	Capacity	Pan	Weight	SKU	List
SW-6KS	13 x 0.001 lb	9.8" x 9.8"	25 lb	7579	\$ 2,080.00
SW-15KS	33 x 0.002 lb	9.8" x 9.8"	25 lb	7580	2,090.00
SW-15KM	33 x 0.002 lb	11.8" x 15"	39 lb	7581	2,440.00
SW-30KM	66 x 0.005 lb	11.8" x 15"	39 lb	7582	2,440.00
SW-60KM	130 x 0.01 lb	11.8" x 15"	39 lb	7583	2,580.00
SW-150KM	330 x 0.02 lb	11.8" x 15"	39 lb	7584	2,680.00
SW-60KL	130 x 0.01 lb	15.4" x 20.9"	49 lb	7585	2,760.00
SW-150KL	330 x 0.02 lb	15.4" x 20.9"	49 lb	7586	2,880.00

Options

SW-03 RS232C Plus comparator relay	1 lb	7587	210.00
SW-04 RS422/485 output for SW	1 lb	7588	145.00
SW-11 Wall mount bracket	2 lb	7589	115.00
HC-06i Rechargeable battery pack	4 lb	6786	55.00

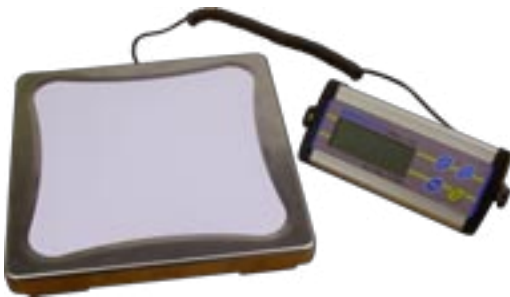

CPWplus 6 Bench/Floor Scale

CPW plus 6 Bench Scale

Rugged construction. The CPWplus series offers an extensive range of models and configurations to accommodate a variety of applications. Desktop or wall mountable indicator. 1" backlit LCD display. Color coded buttons with positive click feel, and simple, quick operation. Keys are: ON/OFF, PRINT/HOLD, UNIT, TARE/ZERO. Weighing units are: lb, kg, oz, lb/oz. Bi-directional RS232 interface allows connection to printers or computers. Using standard commands users can request gross, net and tare weights be sent automatically. Optional Adam data collection software collects scale data and can produce charts and statistics, or export raw data to Microsoft Excel or Word for further analysis. Alkaline battery or AC operation. (6) AA batteries not included.

Part Number	Capacity	Platform	Weight	SKU	List
CPWplus 6	13 x 0.005 lb	11.8" x 11.8"	10 lb	7434	\$ 235.00
CPWplus 15	33 x 0.01 lb	11.8" x 11.8"	10 lb	7435	250.00
CPWplus 35	75 x 0.02 lb	11.8" x 11.8"	10 lb	7436	250.00
CPWplus 75	165 x 0.05 lb	11.8" x 11.8"	10 lb	7437	250.00
CPWplus 150	330 x 0.1lb	11.8" x 11.8"	10 lb	7438	265.00
CPWplus 200	440 x 0.1 lb	11.8" x 11.8"	10 lb	7439	290.00

Options

700100099 Hard carrying case	8 lb	7440	101.00
Quick disconnect connector cable	1 lb	6517	38.00

Service Parts

700400024 AC adapter	1 lb	7042	53.30
02409160 adapter 120 vac	1 lb	252	53.33



TEI Bench/Floor Scale

The TEI is a versatile bench top scale recommended for light industrial weighing, home, office, mail room, shipping and receiving applications. 6.5 digit, 1" high LCD with backlight display. With a generous 12" x 14" stainless steel platter and aluminum subframe it is rugged and durable with adjustable feet. TEI indicator has aluminum alloy housing. Keys for: Hold/Set-up, Print/Function, Acc/Total, Unit/Data, Tare/Preset, Zero/On/Off. Weighing units for: Standard Weighing, Check Weighing, Peak Hold, Percent. Selectable Weighing units for: lb/kg/lb:oz. TEI indicator is programmable for Over/Under, Check Weighing with Sound Alarm, Digital Filtering to meet different working environments. Includes a full duplex RS232 output. Data format 8N1, 701; 7E1, . Protocol: 8 selections. Baud rate 300-19200 bps selectable. TEI scale is powered by 4 (AA) batteries (not included). USB power plug or AC adapter included. Indicator mounts on table or wall with moveable bracket. TEI indicator has a 9' long coil cord with quick disconnect from indicator to base. Indicator can be used as a remote display, using the RS232 port. AC adapter, 6VDC/500mA included.



**TEI
Bench/Floor Scale**

Part Number	Capacity	Pan	Weight	SKU	List
TEI-10	10kg x 0.001kg	12" x 14"	15 lb	5741	\$ 464.00
TEI-20	20kg x 0.002kg	12" x 14"	15 lb	5742	464.00
TEI-100	100kg x 0.01kg	12" x 14"	15 lb	5744	495.00

Service Parts

DHC002 conn 7 pin, indicator			1 lb	7595	19.30
DHC001 conn 7 socket, load cell			1 lb	7596	19.30
TEI-10 indicator w/ bracket			4 lb	6165	240.00
TEI-20 indicator w/ bracket			4 lb	6166	240.00
TEI-50 indicator w/ bracket			4 lb	5737	240.00
TEI-100 indicator w/ bracket			4 lb	6167	240.00
Keysheet TEI-10			1 lb	6168	17.00
Keysheet TEI-20			1 lb	6169	17.00
Keysheet TEI-50 S/N below 10070178			1 lb	6170	17.00
Keysheet TEI-50 S/N above 18120001			1 lb	6191	17.00
Keysheet TEI-100			1 lb	6171	17.00
Adapter 120 VAC			1 lb	6172	29.00



Low Profile Bench Scale

Large 1" LCD display. Lb/kg conversion. Battery power. Auto shutoff. Push button tare. Indicator mounts on table or wall. Keys for LB/KG, TARE/HOLD, ON, OFF. Painted steel construction. Powered by (6) "AA" alkaline batteries or 120 VAC adapter (included) 50/60 Hz.

Part Number	Capacity	Pan	Weight	SKU	List
DR150 low profile	150 x 0.2 lb	12" x 12"	15 lb	6002	\$ 209.00
DR400 low profile	400 x 0.5 lb	12" x 12"	15 lb	6003	231.00



**DR400
Low profile
Bench/Floor Scale**

Prices are subject to change without notice. Please call for current prices.

Other items are available from the manufacturers, please call for prices.



SD Shipping Scale

OHAUS®

SD Shipping Scale

The SD is a well built portable bench scale designed specifically with affordability, utility and everyday usage in mind. Durable painted steel treaded platform, ABS plastic housing and mounting brackets on remote indicator. Ideal for home, office, mail room, shipping and receiving. 4 digit, 7 segment 0.8" high LCD. Weighing Units are lb, kg. Keys are: ON/OFF/ZERO, UNITS/CAL. AC Adapter 9V DC(included) or 360 hour battery operation. (3) "C" Alkaline batteries (not included). Auto shut off feature after 4 minutes of no activity (battery operation only). 1 year warranty.

Part Number	Capacity	Platform	Weight	SKU	List
SD35	77 lb x 0.05 lb	12.4"L x 11"W x 1.77"H	8 lb	6499	\$ 300.00
SD75	165 lb x 0.1 lb	12.4"L x 11"W x 1.77"H	8 lb	6500	294.00
SD200	440 lb x 0.2 lb	12.4"L x 11"W x 1.77"H	8 lb	6501	339.00
SD75L	165 lb x 0.1 lb	20.5"L x 15.7"W x 3"H	36 lb	7242	514.00
SD200L	440 lb x 0.2 lb	20.5"L x 15.7"W x 3"H	36 lb	7243	550.00

OHAUS®

Catapult 1000 Bench Scale

Reliable and precise performance in an affordable, compact design. ABS plastic housing and pan. Unparalleled Ohaus durability. Three capacities, from 20 lb to 165 lb. Reading in pounds and kilograms. Weighing and dynamic weighing modes. Overload protection for tough environments where capacity is exceeded regularly. Ultra portable design. Easy to transport and hold with it's light weight, battery operation and built in handles. Auto shut off mode. Rubber non-slip feet. Digital external calibration. AC powered (included) or (3) C batteries (not included). 1 year warranty.



C11P9 Bench/Floor Scale

Part Number	Capacity	Platform	Weight	SKU	List
C11P9	20 x 0.01 lb	12.4" x 11"	7 lb	6906	\$ 345.00
C11P75	165 x 0.1 lb	12.4" x 11"	7 lb	6908	369.00

Options

80251248	Stainless steel cover	12.4" x 11"	1 lb	6909	73.00
80250400	Stainless steel scoop		2 lb	2025	98.00
80250954	Scoop		8 lb	5274	109.00



ES Bench Scale

Self contained, battery operated. Low profile, rugged, durable and portable. Weighing units are kg, lb, oz, and lb:oz. Display is 1" high LCD. Unique 3-way mounting bracket allows the indicator to be mounted to the base, above the scale platform or on any vertical surface. Full capacity push button tare. **Stainless steel** platforms. Frame is painted steel. Power from 9VDC AC adapter (included) or (6) AA batteries (not included). Battery life is 120 hours or 30 hours continuous use. Battery saving auto off timer will turn unit off after 5 minutes of inactivity. Industrial weighing (not legal for trade). Accuracy +/-1 div. 1 Year warranty.

Part Number	Capacity	Pan	Weight	SKU	List
ES6R	13.2 lb x 0.005 lb 6 kg x 0.002 kg	12.2"x10.8"x1.5"	10 lb	2904	\$ 1,108.00
ES30R	66 lb x 0.05 lb 30 kg x 0.01 kg	12.2"x10.8"x1.5"	10 lb	2905	1,108.00
ES50R	110 lb x 0.05 lb 50 kg x 0.02 kg	12.2"x10.8"x1.5"	10 lb	2906	1,108.00
ES50L	110 lb x 0.05 lb 50 kg x 0.02 kg	20.5"x15.7"x3"	36 lb	2907	1,175.00
ES100L	220 lb x 0.1 lb 100 kg x 0.05 kg	20.5"x15.7"x3"	36 lb	2908	1,175.00
ES200L	440 lb x 0.2 lb 200 kg x 0.1 kg	20.5"x15.7"x3"	37 lb	2909	1,175.00

Service Parts

46001724 AC adapter 120VAC to 12VDC, 500ma w/o prong set			1 lb	6164	67.00
46001776 Prong set, US only			1 lb	6226	29.00
46001780 Prong set, International			1 lb	714	29.00
71148237 cable w/connector ES			1 lb	6712	40.00
71138841 display ES200L			1 lb	2587	685.00



**ES100L
Bench/Floor**



**ES30R
w/mounting bracket (included)**



Defender Digital Field Test Scale

Precise material testing in the construction industry. Portable with a durable plastic carrying case with carrying handle. Backlit LCD display allows for easy reading in low light conditions. The internal battery means that you can operate for 70 hours between recharges. Painted steel base with 150 lb capacity and 0.05 lb readability. You get high precision, high capacity and portability.

Part Number	Capacity	Platform	Weight	SKU	List
D33P75SD	150 lb x 0.05 lb	12.4"Lx11"Wx1.77"H	17.6 lb	2137	\$ 450.00



**D33P75SD
Digital Field Test Scale**

Prices are subject to change without notice. Please call for current prices.

Other items are available from the manufacturers, please call for prices.



D31XW30VR
Bench/Floor

OHAUS®

Defender 3000 Xtreme Bench Scale

The solution to your weighing applications that require dependability within an affordable budget. Ideal for general weighing and simple counting applications in wet or damp environments. 304 stainless steel pan and frame. Simple, rugged, tubular frame base design. 6 digit, 7 segment backlit LCD display. Keys are: ZERO/ON/OFF, PRINT/UNITS, FUNCTION/MODE, TARE/MENU. Weighing units are: lb, oz, lb/oz, kg, g. Parts counting mode with selectable sample sizes, last sample size and average piece weight data. Indicator features a **stainless steel** housing with NEMA 4X / IP65 protection. Flexible mounting capabilities. Hardware configuration lockout switch. Built in bidirectional RS232C with manual/continuous/interval printing. Internal adapter with 100 hour internal rechargeable lead acid battery included. 2 year warranty.

Part Number	Capacity	Pan	Weight	SKU	List
26.8" column					
D32XW60VL	150 x 0.02 lb	16.5" x 21.6" x 5.4"	67 lb	5495	\$ 2,308.00

Options

CBM-910 Impact printer 42 column			5 lb	7426	395.00
80250400 Stainless Steel scoop			2 lb	2025	98.00
80250954 Stainless Steel scoop			2 lb	5274	109.00



Defender 3000 Bench Scale

Large bright backlit LCD display. In checkweighing mode display changes color (yellow/green/red). Tough industrial scale has a 304 stainless steel platform, powder coated steel tubular frame, column and aluminum load cell. Indicator has an ABS housing and powder coated steel mounting bracket. Keys are: ZERO/ON/OFF, PRINT/UNITS, FUNCTION/MODE, TARE/MENU. Weighing units are: lb, oz, lb/oz, kg, g. Auto off. Parts counting mode with selectable sample sizes, last sample size and average piece weight. Bi-directional RS 232C for manual, continuous and interval printing. 9 VDC 500mA, AC adapter. 2 year warranty.

Part Number	Capacity	Pan	Weight	SKU	List
13.8" column					
i-D33P15B1R1	30 x 0.005 lb	12" x 14" x 4.8"	29.5 lb	956	\$ 985.00
i-D33P30B1R1	60 x 0.01 lb	12" x 14" x 4.8"	29.5 lb	957	985.00
i-D33P60B1R1	150 x 0.02 lb	12" x 14" x 4.8"	29.5 lb	958	985.00
26.8" column					
i-D33P75B1L2	150 x 0.02 lb	16.5" x 21.7" x 5.9"	46.2 lb	959	1,195.00
i-D33P150B1L2	300 x 0.05 lb	16.5" x 21.7" x 5.9"	46.2 lb	960	1,195.00
i-D33P150B1X2	300 x 0.05 lb	19.7" x 25.6" x 5.9"	67.3 lb	961	1,295.00
i-D33P300B1X2	600 x 0.1 lb	19.7" x 25.6" x 5.9"	67.3 lb	962	1,295.00
38.6" column					
i-D33P300B1V3	600 x 0.1 lb	23.6" x 31.5" x 6.1"	109 lb	963	1,395.00
i-D33P600B1V3	1,200 x 0.2 lb	23.6" x 31.5" x 6.1"	109 lb	964	1,395.00
Front mount indicator					
i-D33P15B1R5	30 x 0.005 lb	12" x 14" x 4.8"	26.5 lb	2274	\$ 840.00
i-D33P30B1R5	60 x 0.01 lb	12" x 14" x 4.8"	26.5 lb	2275	840.00
i-D33P75B1R5	150 x 0.02 lb	12" x 14" x 4.8"	26.5 lb	2276	840.00
i-D33P75B1L5	150 x 0.02 lb	16.5" x 21.7" x 5.9"	43.2 lb	2277	970.00
i-D33P150B1L5	300 x 0.05 lb	16.5" x 21.7" x 5.9"	43.2 lb	2278	970.00
i-D33P150B1X5	300 x 0.05 lb	19.7" x 25.6" x 5.9"	64.3 lb	2279	1,250.00
i-D33P300B1X5	600 x 0.1 lb	19.7" x 25.6" x 5.9"	64.3 lb	2280	1,250.00
Options					
30699120 USB device interface kit			1 lb	3118	123.00
30429666 ethernet interface kit			1 lb	3119	220.00
80500525 cable RS232 IBM 9 pin male to female			1 lb	3047	254.00
30064203 printer, impact SF40A, AM			2 lb	1754	1,303.00
80251992 printer, thermal STP-103, US			2 lb	7419	1,005.00
30611855 printer Zebra label GK420T			4 lb	3120	953.00
30699122 rechargeable battery kit i-DT33P			4 lb	3121	62.00
30699121 dust cover set(5) i-DT33			1 lb	3122	62.00
30616409 wheel kit, stainless steel, up to 300 lb			12 lb	3123	220.00
30372146 wheel kit, Defender series			8 lb	3124	177.00
Service Parts					
30648433 indicator i-DT33P			4 lb	3116	410.00



D33P15B1R1
Column mount
Bench/Floor



D33P15B1R5
Front mount
Bench/Floor

Prices are subject to change without notice. Please call for current prices.

Other items are available from the manufacturers, please call for prices.



D3XW15B1R1
Column mount
Bench/Floor



D33XW15B1R5
Front mount
Bench/Floor



Defender 3000 Hybrid Bench Scale

Large bright backlit LCD display. In checkweighing mode display changes color (yellow/green/red). Tough industrial scale has a 304 stainless steel platform, powder coated steel tubular frame, column and aluminum load cell. Indicator has a stainless steel housing and mounting bracket. Keys are: ZERO/ON/OFF, PRINT/UNITS, FUNCTION/MODE, TARE/MENU. Weighing units are: lb, oz, lb/oz, kg, g. Auto off. Parts counting mode with selectable sample sizes, last sample size and average piece weight. Bi-directional RS 232C for manual, continuous and interval printing. 9 VDC 500mA, AC adapter. 2 year warranty.

Part Number	Capacity	Pan	Weight	SKU	List
13.8" column					
i-D33XW15B1R1	30 x 0.005 lb	12" x 14" x 4.8"	33.4 lb	2777	\$ 1,100.00
i-D33XW30B1R1	60 x 0.01 lb	12" x 14" x 4.8"	33.4 lb	2778	1,100.00
i-D33XW60B1R1	150 x 0.02 lb	12" x 14" x 4.8"	33.4 lb	2779	1,100.00
26.8" column					
i-D33XW75B1L2	150 x 0.02 lb	16.5" x 21.7" x 5.9"	48.9 lb	2780	1,295.00
i-D33XW150B1L2	300 x 0.05 lb	16.5" x 21.7" x 5.9"	48.9 lb	2781	1,295.00
i-D33XW150B1X2	300 x 0.05 lb	19.7" x 25.6" x 5.9"	67.3 lb	2782	1,395.00
i-D33XW300B1X2	600 x 0.1 lb	19.7" x 25.6" x 5.9"	67.3 lb	2783	1,395.00
38.6" column					
i-D33XW300B1V3	1,200 x 0.1 lb	23.6" x 31.5" x 6.1"	109 lb	2784	1,495.00
i-D33XW600B1V3	1,200 x 0.2 lb	23.6" x 31.5" x 6.1"	109 lb	2785	1,495.00
Front mount indicator					
i-D33XW15B1R5	30 x 0.005 lb	12" x 14" x 4.8"	26.5 lb	3291	840.00
i-D33XW30B1R5	60 x 0.01 lb	12" x 14" x 4.8"	26.5 lb	3292	840.00
i-D33XW75B1R5	150 x 0.02 lb	12" x 14" x 4.8"	26.5 lb	3293	840.00
i-D33XW75B1L5	150 x 0.02 lb	16.5" x 21.7" x 5.9"	43.2 lb	3294	970.00
i-D33XW150B1L5	300 x 0.05 lb	16.5" x 21.7" x 5.9"	43.2 lb	3295	970.00
i-D33XW150B1X5	300 x 0.05 lb	19.7" x 25.6" x 5.9"	64.3 lb	3296	1,250.00
i-D33XW300B1X5	600 x 0.1 lb	19.7" x 25.6" x 5.9"	64.3 lb	3297	1,250.00
Options					
30699120 USB device interface kit			1 lb	3118	123.00
30429666 ethernet interface kit			1 lb	3119	220.00
80500552 cable RS232 XW indicators			1 lb	5253	237.00
30064203 printer, impact SF40A, AM			2 lb	1754	1,303.00
80251992 printer, thermal STP-103, US			2 lb	7419	1,005.00
30611855 printer Zebra label GK420T			4 lb	3120	953.00
30699121 dust cover set(5) i-DT33			1 lb	3122	62.00
30616409 wheel kit, stainless steel, up to 300 lb			12 lb	3123	220.00
30372146 wheel kit, Defender series			8 lb	3124	177.00
Service Parts					
30699120 indicator i-DT33XW			9 lb	2472	525.00



Defender 3000 Washdown Bench Scale

Large bright backlit LCD display. In checkweighing mode display changes color (yellow/green/red). Tough industrial scale has a 304 stainless steel platform, frame, column and IP67 load cell. Indicator has an IP66 protected 304 stainless steel housing and mounting bracket. Keys are: ZERO/ON/OFF, PRINT/UNITS, FUNCTION/MODE, TARE/MENU. Weighing units are: lb, oz, lb/oz, kg, g. Auto off. Parts counting mode with selectable sample sizes, last sample size and average piece weight. Bi-directional RS 232C for manual, continuous and interval printing. 9 VDC 500mA, AC adapter. 2 year warranty.

Part Number	Capacity	Pan	Weight	SKU	List
13.8" column					
i-D33XW15C1R6	30 x 0.005 lb	12" x 14" x 4.8"	33.7 lb	2892	\$ 1,795.00
i-D33XW30C1R6	60 x 0.01 lb	12" x 14" x 4.8"	33.7 lb	2893	1,795.00
i-D33XW60C1R6	150 x 0.02 lb	12" x 14" x 4.8"	33.7 lb	2894	1,795.00
26.8" column					
i-D33XW75C1L7	150 x 0.02 lb	16.5" x 21.7" x 5.9"	51.4 lb	2895	2,025.00
i-D33XW150C1L7	300 x 0.05 lb	16.5" x 21.7" x 5.9"	51.4 lb	2896	2,025.00
i-D33XW150C1X7	300 x 0.05 lb	19.7" x 25.6" x 5.9"	77.8 lb	2897	2,495.00
i-D33XW300C1X7	600 x 0.1 lb	19.7" x 25.6" x 5.9"	77.8 lb	2898	2,495.00
Front mount indicator					
i-D33XW15C1R5	30 x 0.005 lb	12" x 14" x 4.8"	31.5 lb	3002	1,725.00
i-D33XW30C1R5	60 x 0.01 lb	12" x 14" x 4.8"	31.5 lb	3003	1,750.00
i-D33XW75C1R5	150 x 0.02 lb	12" x 14" x 4.8"	31.5 lb	3004	1,750.00
i-D33XW75C1L5	150 x 0.02 lb	16.5" x 21.7" x 5.9"	48.9 lb	3005	1,975.00
i-D33XW150C1L5	300 x 0.05 lb	16.5" x 21.7" x 5.9"	48.9 lb	3006	1,975.00
i-D33XW150C1X5	300 x 0.05 lb	19.7" x 25.6" x 5.9"	75.6 lb	3007	2,450.00
i-D33XW300C1X5	600 x 0.1 lb	19.7" x 25.6" x 5.9"	75.6 lb	3008	2,450.00
Options					
30699120 USB device interface kit			1 lb	3118	123.00
30429666 ethernet interface kit			1 lb	3119	220.00
80500552 cable RS232 XW indicators			1 lb	5253	237.00
30064203 printer, impact SF40A, AM			2 lb	1754	1,303.00
80251992 printer, thermal STP-103, US			2 lb	7419	1,005.00
30611855 printer Zebra label GK420T			4 lb	3120	953.00
30699121 dust cover set(5) i-DT33			1 lb	3122	62.00
30616409 wheel kit, stainless steel, up to 300 lb			12 lb	3123	220.00
30372146 wheel kit, Defender series			8 lb	3124	177.00
Service Parts					
30699120 indicator i-DT33XW			9 lb	2472	525.00



D3XW15C1R6
Column mount
Bench/Floor



D33XW15C1R5
Front mount
Bench/Floor

Prices are subject to change without notice. Please call for current prices.

Other items are available from the manufacturers, please call for prices.



D51P10QR1
ABS Indicator
Painted base,



OHAUS®

Defender 5000 Square base

Keys for ON/ZERO/OFF, PRINT/UNITS, FUNCTION/MODE, TARE/MENU. Three color LED's for over/under. Backlit LCD. Units for lb, oz, lb:oz, kg, g, T & Custom. Weighing modes: Static with single or dual resolution and up to 30,000 display divisions plus 10X temporary resolution increase, Dynamic Weighing, 300,000 div Counting resolution, Checkweighing, Percent, Display hold & Accumulation. Supports GMP/GLP data output with Date, Statistics, Time, User ID, Project ID, Scale ID. Optional interfaces include DC relay control kit, AC relay kit, 2nd RS232 and RS422/485. Integral 100-240 VAC, 50-60Hz power supply. 2 year warranty.

NTEP Legal for Trade 08-039 III Indicator, 10,000 div

NTEP Legal for Trade 01-048A1 III Base, 5,000 div

Canada AM 5687

Stainless Steel Indicator with Painted Base (NEMA4, IP66)

Part Number	Platform	Column	Capacity	Weight	SKU	List
D51P25QR1	12" x 12"	13.8"	50 x .005 lb	38 lb	7367	\$ 1,394.00



Defender 5000 Washdown Bench Scales

Constructed with a stainless steel platform, frame, column, IP67 load cell and IP68/NEMA4X indicator. Keys for ON/ZERO/OFF, PRINT/UNITS, FUNCTION/MODE, TARE/MENU. Backlit LCD. Units for lb, oz, lb:oz, kg, g, metric ton, short ton, custom unit. Application modes: Weighing, Parts Counting, Checkweighing, Percent Weighing, Dynamic Weighing and Display hold. Supports GMP/GLP data output with Date, Statistics, Time, User ID, Project ID, Scale ID. Optional interfaces include DC relay control kit, AC relay kit, 2nd RS232 and RS422/485. Integral 100-240 VAC, 50-60Hz power supply. 2 year warranty

NTEP Legal for Trade 18-065, 5,000d, Indicator IP68

NTEP Legal for Trade 18-077, Platform IP67

Canada Indicator AM-6093, Platform AM-6107

Part Number	Platform	Column	Capacity	Weight	SKU	List
D52XW2WQS6	10" x 10"	13.8"	5 x 0.001 lb	24.3 lb	4380	\$ 1,025.00
D52XW5WQS6	10" x 10"	13.8"	10 x 0.002 lb	24.3 lb	4381	1,025.00
D52XW12WQS6	10" x 10"	13.8"	25 x 0.005 lb	24.3 lb	4382	1,025.00
D52XW12WQR6	12" x 12"	13.8"	25 x 0.005 lb	26.5 lb	4383	2,190.00
D52XW25WQR6	12" x 12"	13.8"	50 x 0.01 lb	26.5 lb	4384	2,190.00
D52XW50WQR6	12" x 12"	13.8"	100 x 0.02 lb	26.5 lb	4385	2,190.00
D52XW25WQL7	18" x 18"	26.8"	50 x 0.01 lb	46.3 lb	4386	3,090.00
D52XW50WQL7	18" x 18"	26.8"	100 x 0.02 lb	46.3 lb	4387	3,090.00
D52XW125WQL7	18" x 18"	26.8"	250 x 0.05 lb	72.8 lb	4388	3,090.00
D52XW50WTX7	18" x 24"	26.8"	100 x 0.02 lb	72.8 lb	4389	3,405.00
D52XW125WTX7	18" x 24"	26.8"	250 x 0.05 lb	72.8 lb	4390	3,405.00
D52XW250WTX7	18" x 24"	26.8"	500 x 0.1 lb	72.8 lb	4391	3,405.00
D52XW50WQV8	24" x 24"	38.6"	100 x 0.02 lb	99.2 lb	4392	3,945.00
D52XW125WQV8	24" x 24"	38.6"	250 x 0.05 lb	99.2 lb	4393	3,945.00
D52XW250WQV8	24" x 24"	38.6"	500 x 0.1 lb	99.2 lb	4394	4,095.00
D52XW500WQV8	24" x 24"	38.6"	1,000 x 0.2 lb	99.2 lb	4395	4,095.00

Service Parts

30097591 Discrete I/O Kit 2in/4 out	1 lb	7972	204.00
30064203 printer, impact SF40A, AM	2 lb	1754	1,303.00
80251992 printer, thermal STP-103, US	2 lb	7419	1,005.00
80500552 Cable RS232, CKW TxxXW	1 lb	5253	609.00
80850080 WinWedge software	1 lb	2436	702.00
30424079 indicator TD52XW IP68/NEMA 4X stainless steel	5.5 lb	7016	1,085.00



D52XW Washdown

Prices are subject to change without notice. Please call for current prices.

Other items are available from the manufacturers, please call for prices.



Defender 5000 Washdown Low Profile no column Bench Scales

Constructed with a stainless steel platform, frame, IP67 load cell and IP68/NEMA4X indicator. Keys for ON/ZERO/OFF, PRINT/UNITS, FUNCTION/MODE, TARE/MENU. Backlit LCD. Units for lb, oz, lb:oz, kg, g, metric ton, short ton, custom unit. Application modes: Weighing, Parts Counting, Checkweighing, Percent Weighing, Dynamic Weighing and Display hold. Supports GMP/GLP data output with Date, Statistics, Time, User ID, Project ID, Scale ID. Optional interfaces include DC relay control kit, AC relay kit, 2nd RS232 and RS422/485. Integral 100-240 VAC, 50-60Hz power supply. 2 year warranty. NTEP Legal for Trade 18-065, 5,000d, Indicator IP68 NTEP Legal for Trade 18-077, Platform IP67 Canada Indicator AM-6093, Platform AM-6107



**D52XW
Washdown
No column**

Part Number	Capacity	Platform	Weight	SKU	List
D52XW2WQS5	5 x 0.001 lb	10" x 10"	24.3 lb	3717	\$ 2,075.00
D52XW5WQS5	10 x 0.002 lb	10" x 10"	24.3 lb	3718	2,075.00
D52XW12WQS5	25 x 0.005 lb	10" x 10"	24.3 lb	3719	2,075.00
D52XW12WQR5	25 x 0.005 lb	12" x 12"	26.5 lb	3720	2,245.00
D52XW25WQR5	50 x 0.01 lb	12" x 12"	26.5 lb	3721	2,245.00
D52XW50WQR5	100 x 0.02 lb	12" x 12"	26.5 lb	3722	2,245.00
D52XW25WQL5	50 x 0.01 lb	18" x 18"	26.5 lb	3723	2,835.00
D52XW50WQL5	100 x 0.02 lb	18" x 18"	26.5 lb	3724	2,835.00
D52XW125WQL5	250 x 0.05 lb	18" x 18"	41.9 lb	3725	2,835.00
D52XW50WTX5	100 x 0.02 lb	18" x 24"	68.4 lb	3726	3,315.00
D52XW125WTX5	250 x 0.05 lb	18" x 24"	68.4 lb	3727	3,315.00
D52XW250WTX5	500 x 0.1 lb	18" x 24"	68.4 lb	3728	3,315.00
D52XW50WQV5	100 x 0.02 lb	24" x 24"	68.4 lb	3729	3,795.00
D52XW125WQV5	250 x 0.05 lb	24" x 24"	68.4 lb	3730	3,795.00

Service Parts

30097591 Discrete I/O Kit 2in/4 out	1 lb	7972	204.00
30064203 SF40A Dot Matrix printer, includes RS232 cable	2 lb	1754	1,303.00
80251992 STP-103 Thermal printer (requires 80500525)	2 lb	7419	1,005.00
80500552 Cable RS232, CKW TxxXW	1 lb	5253	237.00
80850080 WinWedge software	1 lb	2436	702.00
30424079 indicator TD52XW IP68/NEMA 4X stainless steel	5.5 lb	7016	1,085.00



Defender 5000 Standard w/column w/SS indicator

Constructed with a stainless steel platform, powder coated steel frame, column, IP67 load cell and IP68/NEMA4X indicator. Keys for ON/ZERO/OFF, PRINT/UNITS, FUNCTION/MODE, TARE/MENU. Backlit LCD. Units for lb, oz, lb:oz, kg, g, metric ton, short ton, custom unit. Application modes: Weighing, Parts Counting, Checkweighing, Percent Weighing, Dynamic Weighing and Display hold. Supports GMP/GLP data output with Date, Statistics, Time, User ID, Project ID, Scale ID. Optional interfaces include DC relay control kit, AC relay kit, 2nd RS232 and RS422/485. Integral 100-240 VAC, 50-60Hz power supply. 2 year warranty

NTEP Legal for Trade 18-065, 5,000d, Indicator IP68

NTEP Legal for Trade 18-077, Platform IP67

Canada Indicator AM-6093, Platform AM-6107

Part Number	Platform	Column	Capacity	Weight	SKU	List
D52XW12RQR1	12" x 12"	13.8"	25 x 0.005 lb	26.5 lb	7368	\$ 2,075.00
D52XW25RQR1	12" x 12"	13.8"	50 x 0.01 lb	26.5 lb	7369	2,075.00
D52XW50RQR1	12" x 12"	13.8"	100 x 0.02 lb	26.5 lb	7370	2,075.00
D52XW12RTR1	12" x 14"	13.8"	25 x 0.005 lb	28.7 lb	7371	2,075.00
D52XW25RTR1	12" x 14"	13.8"	50 x 0.01 lb	28.7 lb	7372	2,075.00
D52XW50RTR1	12" x 14"	13.8"	100 x 0.02 lb	28.7 lb	7373	2,075.00
D52XW50RQL1	18" x 18"	26.8"	100 x 0.02 lb	44.1 lb	7374	2,490.00
D52XW125RQL1	18" x 18"	26.8"	250 x 0.05 lb	44.1 lb	7375	2,490.00
D52XW50RTX2	18" x 24"	26.8"	100 x 0.02 lb	68.3 lb	7376	2,625.00
D52XW125RTX2	18" x 24"	26.8"	250 x 0.05 lb	68.3 lb	7377	2,625.00
D52XW250RTX2	18" x 24"	26.8"	500 x 0.1 lb	68.3 lb	7378	2,625.00
D52XW50RQV3	24" x 24"	38.6"	100 x 0.02 lb	94.8 lb	7379	2,835.00
D52XW125RQV3	24" x 24"	38.6"	250 x 0.05 lb	94.8 lb	7380	2,835.00
D52XW250RQV3	24" x 24"	38.6"	500 x 0.1 lb	94.8 lb	7381	2,835.00
D52XW500RQV3	24" x 24"	38.6"	1,000 x 0.2 lb	94.8 lb	7382	2,835.00
D52XW125RTV3	23.6" x 31.5"	38.6"	250 x 0.05 lb	114.6 lb	7383	3,525.00
D52XW250RTV3	23.6" x 31.5"	38.6"	500 x 0.1 lb	114.6 lb	7384	3,525.00
D52XW500RTV3	23.6" x 31.5"	38.6"	1,000 x 0.2 lb	114.6 lb	7385	3,525.00

Service Parts

30097591 Discrete I/O Kit 2in/4 out	1 lb	7972	204.00
30064203 SF40A Dot Matrix printer, includes RS232 cable	2 lb	1754	1,303.00
80251992 STP-103 Thermal printer (requires 80500525)	2 lb	7419	1,005.00
80500552 Cable RS232, CKW TxxXW	1 lb	5253	237.00
80850080 WinWedge software	1 lb	2436	702.00
30424079 indicator TD52XW IP68/NEMA 4X stainless steel	5.5 lb	7016	1,085.00



**D52XW
Standard
w/column
w/SS indicator**

Prices are subject to change without notice. Please call for current prices.

Other items are available from the manufacturers, please call for prices.

13-01 Pollitt Dr Ext
Fair Lawn NJ 07410
201-797-2718



www.totalcomp.com
sales@totalcomp.com
Fax 201-797-2287



Defender 5000 Standard w/column w/ABS indicator

Constructed with a stainless steel platform, powder coated steel frame, column, IP67 load cell and IP68/NEMA4X indicator. Keys for ON/ZERO/OFF, PRINT/UNITS, FUNCTION/MODE, TARE/MENU. Backlit LCD. Units for lb, oz, lb:oz, kg, g, metric ton, short ton, custom unit. Application modes: Weighing, Parts Counting, Checkweighing, Percent Weighing, Dynamic Weighing and Display hold. Supports GMP/GLP data output with Date, Statistics, Time, User ID, Project ID, Scale ID. Optional interfaces include DC relay control kit, AC relay kit, 2nd RS232 and RS422/485. Integral 100-240 VAC, 50-60Hz power supply. 2 year warranty

NTEP Legal for Trade 18-065, 5,000d, Indicator IP68

NTEP Legal for Trade 18-077, Platform IP67

Canada Indicator AM-6093, Platform AM-6107



D52P
w/column
ABS indicator

Part Number	Platform	Column	Capacity	Weight	SKU	List
D52P12RQR1	12" x 12"	13.8"	25 x 0.005 lb	24.3 lb	3231	\$ 1,860.00
D52P25RQR1	12" x 12"	13.8"	50 x 0.01 lb	24.3 lb	3232	1,860.00
D52P50RQR1	12" x 12"	13.8"	100 x 0.02 lb	24.3 lb	3233	1,860.00
D52P12RTR1	12" x 14"	13.8"	25 x 0.005 lb	26.5 lb	3234	1,860.00
D52P25RTR1	12" x 14"	13.8"	50 x 0.01 lb	26.5 lb	3235	1,860.00
D52P50RTR1	12" x 14"	13.8"	100 x 0.02 lb	26.5 lb	3236	1,860.00
D52P50RQL2	18" x 18"	26.8"	100 x 0.02 lb	41.9 lb	3237	2,270.00
D52P125RQL2	18" x 18"	26.8"	250 x 0.05 lb	41.9 lb	3238	2,270.00
D52P50RTX2	18" x 24"	26.8"	100 x 0.02 lb	26.5 lb	3239	2,395.00
D52P125RTX2	18" x 24"	26.8"	250 x 0.05 lb	26.5 lb	3240	2,395.00
D52P250RTX2	18" x 24"	26.8"	500 x 0.1 lb	26.5 lb	3241	2,395.00
D52P50RQV3	24" x 24"	38.6"	100 x 0.02 lb	92.6 lb	3242	2,750.00
D52P125RQV3	24" x 24"	38.6"	250 x 0.05 lb	92.6 lb	3243	2,750.00
D52P250RQV3	24" x 24"	38.6"	500 x 0.1 lb	92.6 lb	3244	2,750.00
D52P500RQV3	24" x 24"	38.6"	1,000 x 0.2 lb	92.6 lb	3245	2,750.00
D52P125RTV3	23.6" x 31.5"	38.6"	250 x 0.05 lb	112.4 lb	3246	3,295.00
D52P250RTV3	23.6" x 31.5"	38.6"	500 x 0.1 lb	112.4 lb	3247	3,295.00
D52P500RTV3	23.6" x 31.5"	38.6"	1,000 x 0.2 lb	112.4 lb	3248	3,295.00

Service Parts

30424078 indicator TD52P plastic case				3.75 lb	7132	885.00
---------------------------------------	--	--	--	---------	------	--------

Prices are subject to change without notice. Please call for current prices.

Other items are available from the manufacturers, please call for prices.

OHAUS®**Defender 5000 Standard no column w/SS indicator**

Constructed with a stainless steel platform, powder coated steel frame, IP67 aluminum load cell and IP68/NEMA4X indicator. Keys for ON/ZERO/OFF, PRINT/UNITS, FUNCTION/MODE, TARE/MENU. Backlit LCD. Units for lb, oz, lb:oz, kg, g, metric ton, short ton, custom unit. Application modes: Weighing, Parts Counting, Checkweighing, Percent Weighing, Dynamic Weighing and Display hold. Supports GMP/GLP data output with Date, Statistics, Time, User ID, Project ID, Scale ID. Optional interfaces include DC relay control kit, AC relay kit, 2nd RS232 and RS422/485. Integral 100-240 VAC, 50-60Hz power supply. 2 year warranty

NTEP Legal for Trade 18-065, 5,000d, Indicator IP68

NTEP Legal for Trade 18-077, Platform IP67

Canada Indicator AM-6093, Platform AM-6107



D52XW
w/SS indicator

Part Number	Capacity	Platform	Weight	SKU	List
D52XW12RQR5	25 x 0.005 lb	12" x 12"	24.3 lb	4263	\$ 1,970.00
D52XW25RQR5	50 x 0.01 lb	12" x 12"	24.3 lb	4264	1,970.00
D52XW50RQR5	100 x 0.02 lb	12" x 12"	24.3 lb	4265	1,970.00
D52XW12RTR5	25 x 0.005 lb	12" x 14"	26.5 lb	4266	2,045.00
D52XW25RTR5	50 x 0.01 lb	12" x 14"	26.5 lb	4267	2,045.00
D52XW50RTR5	100 x 0.02 lb	12" x 14"	26.5 lb	4268	2,045.00
D52XW50RQL5	100 x 0.02 lb	18" x 18"	39.7 lb	4269	2,350.00
D52XW125RQL5	250 x 0.05 lb	18" x 18"	39.7 lb	4270	2,350.00
D52XW50RTX5	100 x 0.02 lb	18" x 24"	61.7 lb	4271	2,490.00
D52XW125RTX5	250 x 0.05 lb	18" x 24"	61.7 lb	4272	2,490.00
D52XW250RTX5	500 x 0.1 lb	18" x 24"	61.7 lb	4273	2,490.00
D52XW50RQV5	100 x 0.02 lb	24" x 24"	83.8 lb	4274	2,620.00
D52XW125RQV5	250 x 0.05 lb	24" x 24"	83.8 lb	4275	2,620.00
D52XW250RQV5	500 x 0.1 lb	24" x 24"	83.8 lb	4276	2,620.00
D52XW125RTV5	250 x 0.05 lb	23.6" x 31.5"	103.6 lb	4277	3,105.00

Service Parts

30424079 indicator TD52XW IP68/NEMA 4X stainless steel 5.5 lb 7016 1,085.00

Prices are subject to change without notice. Please call for current prices.

Other items are available from the manufacturers, please call for prices.

13-01 Pollitt Dr Ext
Fair Lawn NJ 07410
201-797-2718

Totalcomp®
Scales & Balances

www.totalcomp.com
sales@totalcomp.com
Fax 201-797-2287



D52P
ABS indicator

OHAUS®

Defender 5000 Standard no column w/ABS indicator

Constructed with a stainless steel platform, powder coated steel frame, aluminum IP67 load cell and ABS plastic indicator. Keys for ON/ZERO/OFF, PRINT/UNITS, FUNCTION/MODE, TARE/MENU. Backlit LCD. Units for lb, oz, lb:oz, kg, g, metric ton, short ton, custom unit. Application modes: Weighing, Parts Counting, Checkweighing, Percent Weighing, Dynamic Weighing and Display hold. Supports GMP/GLP data output with Date, Statistics, Time, User ID, Project ID, Scale ID. Optional interfaces include DC relay control kit, AC relay kit, 2nd RS232 and RS422/485. Integral 100-240 VAC, 50-60Hz power supply. 2 year warranty
 NTEP Legal for Trade 18-065, 5,000d, Indicator IP68
 NTEP Legal for Trade 18-077, Platform IP67
 Canada Indicator AM-6093, Platform AM-6107

Part Number	Capacity	Platform	Weight	SKU	List
D52P12RQR5	25 x 0.005 lb	12" x 12"	22.0 lb	5307	\$ 1,715.00
D52P25RQR5	50 x 0.01 lb	12" x 12"	22.0 lb	5308	1,715.00
D52P50RQR5	100 x 0.02 lb	12" x 12"	22.0 lb	5309	1,715.00
D52P12RTR5	25 x 0.005 lb	12" x 14"	24.3 lb	5310	1,785.00
D52P25RTR5	50 x 0.01 lb	12" x 14"	24.3 lb	5311	1,785.00
D52P50RTR5	100 x 0.02 lb	12" x 14"	24.3 lb	5312	1,785.00
D52P50RQL5	100 x 0.02 lb	18" x 18"	37.5 lb	5313	2,100.00
D52P125RQL5	250 x 0.05 lb	18" x 18"	37.5 lb	5314	2,100.00
D52P50RTX5	100 x 0.02 lb	18" x 24"	59.5 lb	5315	2,195.00
D52P125RTX5	250 x 0.05 lb	18" x 24"	59.5 lb	5316	2,195.00
D52P250RTX5	500 x 0.1 lb	18" x 24"	59.5 lb	5317	2,195.00
D52P50RQV5	100 x 0.02 lb	24" x 24"	81.6 lb	5318	2,345.00
D52P125RQV5	250 x 0.05 lb	24" x 24"	81.6 lb	5319	2,345.00
D52P250RQV5	500 x 0.1 lb	24" x 24"	81.6 lb	5320	2,345.00
D52P125RTV5	250 x 0.05 lb	23.6" x 31.5"	101.4 lb	5321	3,095.00

Options

30412537 WiFi/BT dongle requires 30424406	1.00 lb	5337	303.00
30424406 USB Host for dongle TD52	1.00 lb	5338	185.00

Service Parts

30424078 indicator TD52P plastic case	3.75 lb	7132	885.00
---------------------------------------	---------	------	--------

OHAUS®

Defender 7000 Rectangular base

Numeric keypad with alphanumeric text entry. Keys for ON/ZERO/OFF, PRINT/UNITS, FUNCTION/MODE, TARE/MENU, LIBRARY/EXIT. Three color LED's for over/under. Dual line backlit LCD with multi-language support. Units for lb, lb:oz, kg, g, T & Custom. Weighing modes: Static with single or dual resolution and up to 50,000 display divisions plus 10X temporary resolution increase, Dynamic Weighing, 500,000 div Counting Resolution with second scale connection, Checkweighing, Percent, Display Hold & Accumulation. Library storage for up to 255 records. Supports GMP/GLP data output with Date, Statistics, Time, User ID, Project ID, Scale ID. Optional interfaces include DC relay control kit, AC relay kit, 2nd RS232 and RS422/485. Integral 100-240 VAC, 50-60Hz power supply. 2 year warranty.

NTEP Legal for Trade 09-102, 10,000 III Indicator

NTEP Legal for Trade 99-203A3, 3,000 III Base

Plastic indicator with bracket & painted base (6C Cells)

Part Number	Platform	Capacity	Weight	SKU	List
D71P15HR5	12" x 14"	30 x 0.005 lb	36 lb	7879	\$ 1,095.00

Service Parts

30126959 indicator T72XW SS	9 lb	7618	1,150.00
30132164 USB I/O kit T72RW	1 lb	7619	228.00



D71P15HR5
Indicator ABS plastic
Base, painted



Prices are subject to change without notice. Please call for current prices.

Other items are available from the manufacturers, please call for prices.



CQ31 Multi Functional Bench Scale

Complete scale composed of the Ohaus CD-31 indicator, Ohaus base and 9 ft of load cell cable. Base has **stainless steel** platform with painted steel frame. Weighing units: lb, g, kg, user programmable custom unit. Application modes: % weighing, checkweighing, parts counting, dynamic weighing. Front panel switches are ENTER, PRINT, TARE, >0<, MODE, SETUP, GTN, UNITS. RS232 bidirectional interface. Digital calibration for zero and span. 2 Year warranty. 120 VAC adapter(included), 50/60 Hz.

Canadian AM-5422 & AM-5339

NTEP Legal for Trade 01-049 III/IIIL 5,000 div. Recalibration is required for NTEP use.

Part Number	Factory	NTEP	Weight	SKU	List
24" x 24" Platform, 6.4"H					
CQ250XL31	500 x 0.05 lb	500 x 0.1 lb	83 lb	4255	\$ 1,390.00

Service Parts

46001802 AC adapter 120 VAC w/o prong set	1 lb	716	82.00
46001780 Prong set, International	1 lb	714	29.00
46001776 Prong set, US only	1 lb	6226	29.00



**CQ50L31
Bench/Floor**





**TB Bench Scale
w/ optional column**

TB 1212/1214



**TB Bench scale
TRWS Indicator
TBT Base
Stainless Steel
w/ optional column**

TB 1616/2424



TB All Stainless Steel

All **stainless steel** base and heavy gauge **stainless steel** pan. Has TRWS indicator with **Stainless steel** load cell. Integral overload protection is provided for both static and dynamic overloads.

Adjustable rubber feet. Bubble level.
2 mv/v, 0.02% total error, 385/350 ohms, 9 ft 6 conductor cable.
NTEP Legal for Trade 13-090 Class III 6,000 div (Indicator)
NTEP Legal for Trade 14-050 Class III 5,000 div (Platform)

Part Number	Capacity	Weight	SKU	List
12" x 12" Platform x 4.25" High				
TB-1212-15-SS	15 x 0.005 lb	34 lb	7773	\$ 692.00
TB-1212-30-SS	30 x 0.01 lb	34 lb	7774	692.00
TB-1212-50-SS	50 x 0.01 lb	34 lb	7775	692.00
TB-1212-100-SS	100 x 0.02 lb	34 lb	7776	692.00
TB-1212-200-SS	200 x 0.05 lb	34 lb	7777	692.00
12" x 14" Platform x 4.25" High				
TB-1214-15-SS	15 x 0.005 lb	37 lb	7778	709.00
TB-1214-30-SS	30 x 0.01 lb	37 lb	7779	709.00
TB-1214-50-SS	50 x 0.01 lb	37 lb	7780	709.00
TB-1214-100-SS	100 x 0.02 lb	37 lb	7781	709.00
TB-1214-200-SS	200 x 0.05 lb	37 lb	7782	709.00
16" x 16" Platform x 4.25" High				
TB-1616-15-SS	15 x 0.005 lb	39 lb	7783	725.00
TB-1616-30-SS	30 x 0.01 lb	39 lb	7784	725.00
TB-1616-50-SS	50 x 0.01 lb	39 lb	7785	725.00
TB-1616-100-SS	100 x 0.02 lb	39 lb	7786	725.00
TB-1616-300-SS	300 x 0.05 lb	39 lb	7787	725.00
24" x 24" Platform x 4.25" High				
TB-2424-100-SS	100 x 0.02 lb	94 lb	7788	1,121.00
TB-2424-200-SS	200 x 0.05 lb	94 lb	7789	1,121.00
TB-2424-250-SS	250 x 0.05 lb	94 lb	7790	1,121.00
TB-2424-500-SS	500 x 0.1 lb	94 lb	7791	1,121.00
TB-2424-1000-SS	1,000 x 0.2 lb	94 lb	7792	1,121.00

Options

TBT-1212/1214 SS square column 8" high	46.50	4 lb	7661	
TBT-1616/2424-SS column 13" high		4 lb	6885	56.64
TBT-1616/2424 SS column 23" high		4 lb	7662	63.80
TBT-1616/2424 SS column 26" high		4 lb	7663	68.40

Service Parts

Foot for 12" x 12" + 12" x 14"				
TB-M10-SPB-SS foot M10, 2 1/8" dia		1 lb	7673	5.17
Foot for 16" x 16" + 24" x 24"				
TB-M12-SPB-SS foot M12, 2 3/4" dia		1 lb	7660	5.28
TB-M12-PB-MS foot M12, 2 3/4" dia		1 lb	7666	5.35

Prices are subject to change without notice. Please call for current prices.

Other items are available from the manufacturers, please call for prices.

TBP Painted Mild Steel

Painted mild steel base and heavy gauge stainless steel pan. has TWP indicator with ABS plastic enclosure, Aluminum or nickel plated steel load cell. Integral overload protection is provided for both static and dynamic overloads. Adjustable rubber feet. Bubble level. 2 mv/v, 0.02% total error, 405/350 ohms, 9 ft 6 conductor cable.

NTEP Legal for Trade 13-091 Class III 6,000 div (Indicator)

NTEP Legal for Trade 14-050 Class III 5,000 div (Platform)

Part Number	Capacity	Weight	SKU	List
16" x 16" Platform x 4.75" High w/ aluminum load cell				
TBP-1616-50-CS	50 x 0.005 lb	33 lb	7793	\$ 373.00
TBP-1616-100-CS	100 x 0.01 lb	33 lb	7794	373.00
TBP-1616-200-CS	200 x 0.02 lb	33 lb	7795	373.00
TBP-1616-400-CS	400 x 0.05 lb	33 lb	7796	373.00
24" x 24" Platform x 5.5" High w/ nickel plated steel load cell				
TBP-2424-100-CS	100 x 0.01 lb	85 lb	7797	685.00
TBP-2424-200-CS	200 x 0.02 lb	85 lb	7798	685.00
TBP-2424-250-CS	250 x 0.05 lb	85 lb	7799	685.00
TBP-2424-500-CS	500 x 0.05 lb	85 lb	7800	685.00
TBP-2424-1000-CS	1,000 x 0.1 lb	85 lb	7801	685.00

Options

TBT-1616/2424-SS pole and bracket 13" high	4 lb	6885	56.64
TBT-1616/2424 SS pole and bracket 23" high	4 lb	7662	63.80
TBT-1616/2424 SS pole and bracket 26" high	4 lb	7663	68.40

Service Parts

Foot for 16" x 16" + 24" x 24"

TBT-M12-SPB-SS foot M12, 2 3/4" dia	1 lb	7660	5.28
TBT-M12-PB-MS foot M12, 2 3/4" dia	1 lb	7666	5.39



TB 1616/2424
TBP Bench scale
TWP Indicator, plastic
TBT Base, painted
w/ optional column



TBL-1212/1214
TBL Bench Scale
 w/ optional column



TBL Bench scale
TLI Indicator
TBT Base
Stainless Steel
 w/ optional column



TBL 1616/2424

TBL All Stainless Steel

All **stainless steel** base and heavy guage **stainless steel** pan. Has TLI indicator with stainless steel enclosure and rechargeable battery **Stainless steel** load cell. Integral overload protection is provided for both static and dynamic overloads.

Adjustable rubber feet. Bubble level.
 2 mv/v, 0.02% total error, 385/350 ohms, 9 ft 6 conductor cable.

NTEP Legal for Trade 13-091 Class III 6,000 div (Indicator)

NTEP Legal for Trade 14-050 Class III 5,000 div (Platform)

Part Number	Capacity	Weight	SKU	List
12" x 12" Platform x 4.25" High				
TBL-1212-15-SS	15 x 0.002 lb	34 lb	8197	\$ 730.00
TBL-1212-30-SS	30 x 0.005 lb	34 lb	8198	730.00
TBL-1212-50-SS	50 x 0.005 lb	34 lb	8199	730.00
TBL-1212-100-SS	100 x 0.01 lb	34 lb	8200	730.00
TBL-1212-200-SS	200 x 0.02 lb	34 lb	8201	730.00
12" x 14" Platform x 4.25" High				
TBL-1214-15-SS	15 x 0.002 lb	37 lb	8202	746.00
TBL-1214-30-SS	30 x 0.005 lb	37 lb	8203	746.00
TBL-1214-50-SS	50 x 0.005 lb	37 lb	8204	746.00
TBL-1214-100-SS	100 x 0.01 lb	37 lb	8205	746.00
TBL-1214-200-SS	200 x 0.02 lb	37 lb	8206	746.00
16" x 16" Platform x 4.25" High				
TBL-1616-15-SS	15 x 0.002 lb	39 lb	8207	756.00
TBL-1616-30-SS	30 x 0.005 lb	39 lb	8208	756.00
TBL-1616-50-SS	50 x 0.005 lb	39 lb	8209	756.00
TBL-1616-100-SS	100 x 0.01 lb	39 lb	8210	756.00
TBL-1616-300-SS	300 x 0.02 lb	39 lb	8211	756.00
24" x 24" Platform x 4.25" High				
TBL-2424-100-SS	100 x 0.01 lb	94 lb	8212	1,195.00
TBL-2424-250-SS	250 x 0.05 lb	94 lb	8213	1,195.00
TBL-2424-500-SS	500 x 0.05 lb	94 lb	8214	1,195.00
TBL-2424-1000-SS	1,000 x 0.1 lb	94 lb	8215	1,195.00

Options

TBT-1212/1214-SS square column 8" high	4 lb	7661	46.50
TBT-1616/2424-SS column 13" high	4 lb	6885	56.64
TBT-1616/2424-SS column 23" high	4 lb	7662	63.80
TBT-1616/2424-SS column 26" high	4 lb	7663	68.40

Service Parts

Foot for 12" x 12" + 12" x 14"				
TB-M10-SPB-SS foot M10, 2 1/8" dia	1 lb	7673	5.17	
Foot for 16" x 16" + 24" x 24"				
TB-M12-SPB-SS foot M12, 2 3/4" dia	1 lb	7660	5.28	
TB-M12-PB-MS foot M12, 2 3/4" dia	1 lb	7666	5.39	

Prices are subject to change without notice. Please call for current prices.

Other items are available from the manufacturers, please call for prices.



7400 Stainless Steel Digital Bench Scale

Advanced features. One button, easy to operate. Quad spring base, 1000% overload protection. Checkweigh indicators. Zero band checkweighing is an included feature with OVER/ACCEPT/UNDER. LB, KG, OZ, LB & OZ weight display. IP69K/NEMA 4X washdown safe 304 stainless steel construction. 115 VAC, 60 Hz, 10 watts.

NTEP Legal for Trade 99-129A2 Class III 5,000 div (7400M)

NTEP Legal for Trade 97-097A1 Class III 5,000 div (15 x 15)

NTEP Legal for Trade TEP 97-097A Class III 5,000 div

NTEP Legal for Trade 02-086 Class III 3,000 div (18 x 18)

NTEP Legal for Trade 05-062 Class III 3,000 div (18 x 24, 24 x 24)

Canadian approval AM-5241, AM-5347

Canadian approval AM-5188, AM-5241, AM-5475



7400 Stainless Steel Digital Bench Scale

Part Number	Capacity	Platform	Weight	SKU	List
10" x 10" Platform w/U bracket					
7402*	2 x 0.0005 lb	10" x 10"	21 lb	6827	\$ 1,555.00
7405*	5 x 0.001 lb	10" x 10"	21 lb	6828	1,555.00
7410*	10 x 0.002 lb	10" x 10"	21 lb	6829	1,555.00

* Includes up overload stop

7425	25 x 0.005 lb	10" x 10"	21 lb	6830	1,555.00
7450	50 x 0.01 lb	10" x 10"	21 lb	6831	1,555.00

12" x 12" Platform w/U bracket

7450/12	50 x 0.01 lb	12" x 12"	26 lb	6832	1,670.00
74100/12	100 x 0.02 lb	12" x 12"	26 lb	6833	1,670.00

15" x 15" Platform w/U bracket

7450/15	50 x 0.01 lb	15" x 15"	41 lb	6834	1,915.00
74100/15	100 x 0.02 lb	15" x 15"	41 lb	6835	1,915.00
74200/15	200 x 0.05 lb	15" x 15"	41 lb	6836	1,915.00

15" x 15" Platform w/20" column

7450/15-C20	50 x 0.01 lb	15" x 15"	71 lb	6837	2,190.00
74100/15-C20	100 x 0.02 lb	15" x 15"	71 lb	6838	2,190.00
74200/15-C20	200 x 0.05 lb	15" x 15"	71 lb	6839	2,190.00

Shipped in 2 cartons 19" x 19" x 16" and 14" x 15" x 28", 41 lb and 30 lb.

18" x 18" Platform w/20" column

74100/18S-C20	100 x 0.02 lb	18" x 18"	87 lb	6841	2,465.00
74250/18S-C20	250 x 0.02 lb	18" x 18"	87 lb	6842	2,465.00
74500/18S-C20	500 x 0.05 lb	18" x 18"	87 lb	6843	2,465.00

Shipped in 2 cartons 21" x 21" x 17" and 14" x 15" x 28", 69 lb and 30 lb.

18" x 24" Platform w/20" column

74250/1824-C20	250 x 0.05 lb	18" x 24"	105 lb	6844	2,665.00
74500/1824-C20	500 x 0.1 lb	18" x 24"	105 lb	6845	2,665.00

Shipped in 2 cartons 28" x 28" x 9" and 14" x 15" x 28", 75 lb and 30 lb.

24" x 24" Platform w/20" column

74250/2424-C20	250 x 0.05 lb	24" x 24"	116 lb	6847	2,945.00
74500/2424-C20	500 x 0.1 lb	24" x 24"	116 lb	6848	2,945.00
741000/2424-C20	1,000 x 0.2 lb	24" x 24"	116 lb	6849	2,945.00

Shipped in 2 cartons 30" x 28" x 16" and 14" x 15" x 28", 86 lb and 30 lb.

* Includes up overload stop.

Service Parts

7400M Digital Weight Indicator			10 lb	6563	895.00
--------------------------------	--	--	-------	------	--------

Prices are subject to change without notice. Please call for current prices.

Other items are available from the manufacturers, please call for prices.

13-01 Pollitt Dr Ext
Fair Lawn NJ 07410
201-797-2718



www.totalcomp.com
sales@totalcomp.com
Fax 201-797-2287



**7010XL
Bench/Floor**



doran

7000XL Stainless Steel Bench/Floor Scale

Rugged 304 Washdown Safe **Stainless Steel** construction. Displays Weight In lb, kg, oz, g or lb & oz. Front panel keys: ZERO, PRINT, UNITS. Shockproof base with Quad Spring design that protects against shock and overload damage. 120 VAC, 60 Hz. Indicator 6" x 10" x 3"D 10 lb.

Canadian approval AM-5188, AM-5241

NTEP Legal for Trade 91-106 III 5,000 div (5 lb to 200 lb only)

Part Number	Capacity	Platform	Weight	SKU	List
10" x 10" Platform					
7002XL	2 lb x 0.0005 lb	10" x 10"	21 lb	6193	\$ 1,425.00
7005XL	5 lb x 0.001 lb	10" x 10"	21 lb	3626	1,425.00
7010XL	10 lb x 0.002 lb	10" x 10"	21 lb	3627	1,425.00
12" x 12" Platform					
7025XL	25 lb x 0.005 lb	10" x 10"	21 lb	3628	1,425.00
7050XL	50 lb x 0.01 lb	10" x 10"	21 lb	3629	1,425.00
15" x 15" Platform					
7050XL/15	50 lb x 0.01 lb	15" x 15"	42 lb	2128	1,785.00
	22.7kg x 5g				
7100XL/15	100 lb x 0.02 lb	15" x 15"	42 lb	2129	1,785.00
	45kg x 10g				
7200XL/15	200 lb x 0.05 lb	15" x 15"	42 lb	2130	1,785.00
	91kg x 20g				
15" x 15" Platform					
7050XL/15-C20	50 x 0.01 lb	15" x 15"	54 lb	3633	2,060.00
7100XL/15-C20	100 x 0.02 lb	15" x 15"	54 lb	3634	2,060.00
7200XL/15-C20 *	200 x 0.05 lb	15" x 15"	54 lb	3635	2,060.00
Shipped in 2 cartons 19" x 19" x 16" and 14" x 15" x 28", 41 lb and 30 lb.					
18" x 18" Platform					
7100XL/18S-C20	100 x 0.02 lb	18" x 18"	60 lb	3636	2,335.00
7250XL/18S-C20 *	250 x 0.05 lb	18" x 18"	60 lb	3637	2,335.00
7500XL/18S-C20	500 x 0.1 lb	18" x 18"	60 lb	3638	2,335.00
Shipped in 2 cartons 21" x 21" x 17" and 14" x 15" x 28", 69 lb and 30 lb.					
18" x 24" Platform					
7250XL/1824-C20	250 x 0.05 lb	18" x 24"	75 lb	3641	2,535.00
7500XL/1824 -C20*	500 x 0.1 lb	18" x 24"	75 lb	3642	2,535.00
Shipped in 2 cartons 28" x 28" x 9" and 14" x 15" x 28", 75 lb and 30 lb.					
24" x 24" Platform					
7250XL/2424-C20	250 x 0.05 lb	24" x 24"	84 lb	3646	2,815.00
7500XL/2424-C20 *	500 x 0.1 lb	24" x 24"	84 lb	3647	2,815.00
71000XL/2424-C20*	1,000 x 0.2 lb	24" x 24"	84 lb	3648	2,815.00
Shipped in 2 cartons 30" x 28" x 16" and 14" x 15" x 28", 86 lb and 30 lb.					

* This model does not have lb & oz weight display capability.

* Not NTEP

Service Parts

7000XLM Digital Indicator	10 lb	3632	765.00
SUB0427 Touch Panel for 7000XLS (4) screws	1 lb	4106	200.00
SUB0846 Touch Panel for 7000XL (12) screws	0.47 lb	4107	131.43
ENC 0148 platter 10" x 10"	3 lb	3671	85.71
SUB0210-1 large knob kit (1) knob (1)washer	0.07 lb	4049	14.30
SUB0210-2 small knob kit (2) knobs (2)washers	0.07 lb	4050	23.90



2200 Bench Scale

Washdown safe 304 stainless steel construction. Displays weight in lb, oz, kg, g, lb & oz. 6 digit, red LED 0.56" high. Keys are: TARE, GROSS/NET, ZERO, PRINT, UNITS, ACCUM, ID, CLEAR, ENTER, SET POINT, DECIMAL POINT, KEYPAD 0-9. Indicators are: Net, zero, batt, mot. Bi-directional RS232 serial ports. Eight digital outputs. Internal rechargeable battery. 115VAC, 50/60 Hz. 2 year warranty
Indicator size 6"H x 10"W x 3"D

NTEP Legal for Trade Indicator 06-101A1 Base 05-062

Part Number	Capacity	Weight	SKU	List
10" x 10" platform				
22002-C14	2 x 0.0005 lb	21 lb	7208	\$ 1,660.00
22005-C14	5 x 0.001 lb	21 lb	7209	1,660.00
22010-C14	10 x 0.002 lb	21 lb	7210	1,660.00
22025-C14	25 x 0.005 lb	21 lb	7211	1,660.00
22050-C14	50 x 0.01 lb	21 lb	7212	1,660.00
12" x 12" platform				
22050/12-C14	50 x 0.01 lb	26 lb	7213	1,775.00
22100/12-C14	100 x 0.02 lb	26 lb	7214	1,775.00
15" x 15" platform				
22050/15-C14	50 x 0.01 lb	41 lb	7215	2,020.00
22100/15-C14	100 x 0.02 lb	41 lb	7216	2,020.00
22200/15-C14	200 x 0.05 lb	41 lb	7217	2,020.00
15" x 15"				
22050/15-C20	50 x 0.01 lb	71 lb	7218	2,090.00
22100/15-C20	100 x 0.02 lb	71 lb	7219	2,090.00
22200/15-C20	200 x 0.05 lb	71 lb	7220	2,090.00
18" x 18"				
22100/18S-C20	100 x 0.02 lb	87 lb	7222	2,365.00
22250/18S-C20	250 x 0.05 lb	87 lb	7223	2,365.00
22500/18S-C20	500 x 0.1 lb	87 lb	7224	2,365.00
18" x 24"				
22250/1824-C20	250 x 0.05 lb	105 lb	7225	2,565.00
22500/1824-C20	500 x 0.1 lb	105 lb	7226	2,565.00
24" x 24"				
22250/2424-C20	250 x 0.05 lb	116 lb	7227	2,845.00
22500/2424-C20	500 x 0.1 lb	116 lb	7228	2,845.00
221000/2424-C20	1,000 x 0.2 lb	116 lb	7229	2,845.00
Service Parts				
ENC 0148 platter	10" x 10"	3 lb	3671	85.71



**APS 2200P
w/ column**



7000 Stainless Steel Bench/Floor Scale

Service parts only for Doran 7000.

Part Number	Weight	SKU	List
Service Parts			
SWI0007 Rubber boot for switch	1 lb	1311	\$ 8.00
SUB0004-3 foot 10-24 thread pk(6)	1 lb	1915	30.00
SUB00040-4 foot M6 thread pk(6)	1 lb	4994	35.00



**7050 Stainless Steel
Bench/Floor**

Prices are subject to change without notice. Please call for current prices.

Other items are available from the manufacturers, please call for prices.



**8025XL/12
Bench Scale
w/ optional 14" column**



8000XL Bench/Floor Scale

Service parts only for 8000XL
NTEP Legal for Trade (indicator) CC #99-129 Class III 10,000 div

Part Number	Capacity	Platform	Weight	SKU	List
Service Parts					
SUB0853 Battery with cables			2 lb	6657	113.00
PCA415 Main Board 4300M/8000XL			1 lb	6219	660.00
SUB0210-1 large knob kit (1) knob (1)washer			0.07 lb	4049	14.30
SUB0210-2 small knob kit (2) knobs (2)washers			0.07 lb	4050	23.90
SUB0397 front enclosure 8000XL			1 lb	4061	320.00



MVP Bench/Floor Scale

Simple, intuitive, designed to withstand the use and abuse of extreme industrial applications. Seven overload stops provide outstanding load cell protection. Two part polyurethane paint provides excellent wear and abrasion protection. 6 digit, 0.56" red LED. Keys are: ZERO, GROSS/NET, TARE, UNITS, PRINT, ON/OFF. Weighing units are: g, lb, kg, oz, lb:oz. Bi-directional RS232. 115 VAC 60Hz, adapter, UL (230 VAC optional) Indicator 7.5"W x 1.75"D x 3.5"H
NTEP Legal for Trade 05-061 Class III 5,000 div (Indicator)
NTEP Legal for Trade 05-062 Class III 5,000 div (Base)
Canada pending

Part Number	Capacity	Platform	Weight	SKU	List
MVP3100	100 x 0.02 lb	18" x 18"	67 lb	6084	\$ 1,101.00
MVP3250	250 x 0.05 lb	18" x 18"	67 lb	6085	1,101.00
MVP5250	250 x 0.05 lb	24" x 24"	85 lb	6089	1,276.00
MVP5500	500 x 0.1 lb	24" x 24"	85 lb	6091	1,276.00
MVP51000	1,000 x 0.2 lb	24" x 24"	85 lb	6092	1,276.00

36" Column

MVP3100-36	100 x 0.02 lb	18" x 18"	97 lb	6249	1,276.00
MVP3250-36	250 x 0.05 lb	18" x 18"	97 lb	6250	1,276.00
MVP5250-36	250 x 0.05 lb	24" x 24"	115 lb	6254	1,451.00
MVP5500-36	500 x 0.1 lb	24" x 24"	115 lb	6255	1,451.00
MVP51000-36 *	1,000 x 0.2 lb	24" x 24"	115 lb	6256	1,451.00

* No lb:oz weight display

Options

DSOPT-001 RS232 Serial Data Output w/ 4 wire shielded cable, 10 ft female 9 pin D connector			1 lb	6093	75.00
DSOPT-002 RS232 Serial Data Output w/ 4 wire shielded cable, 10 ft male 25 pin D connector			1 lb	6094	35.00
DSOPT-003 230 VAC operation			2 lb	6095	25.00
MVPOPT-001 Mobility kit w/ (4) 3" dia locking swivel casters			20 lb	6096	75.00
MVPOPT-002 24" x 24" Stainless steel platter			30 lb	6097	200.00
MVPOPT-003 18" x 18" Stainless steel platter			25 lb	6098	250.00
DMSOPT04 24" x 24" Roller conveyor w/ galvanized rollers 1-7/8" dia			45 lb	6099	350.00



**MVP Bench Scale
W/36" column**





DP-6900 Bench Scale

Bench and receiving scales. Applications for checkweighing, gross/net weighing and basic weighing. Rechargeable battery 240 hours of continuous operation with charging time of 12 hours and AC operation. Programable auto-off. Weighing units are: lb, kg, oz, lb:oz. 115 VAC 60Hz, adapter. Platform 13.8" x 19.7" x 30.8"H.
NTEP Legal for Trade 17-019

Part Number	Capacity	Weight	SKU	List
DP-6900-60	60 x 0.02 lb	39 lb	1480	\$ 814.64
DP-6900-150	150 x 0.05 lb	39 lb	1481	814.64
DP-6900-3000	300 x 0.1 lb	39 lb	1482	814.64

Service Parts

LHV-5000-690640 AC adapter for 6900	0.27 lb	1493	40.00
-------------------------------------	---------	------	-------



DP-6900-150



BW
Bench/Floor



BW Battery Powered Bench/Floor Scale

Rechargeable or dry battery operation. Environmentally sealed (washdown IP65). Full 5 digit weight display (LCD) with backlight. Counting function. Standard RS232 output. Low battery indicator. Fast battery recharge. Battery life without use of backlight: Rechargeable batteries 100 hrs., Manganese 200 hrs., Alkaline 300 hrs Auto zero tracking. Comparator function (High, OK, Low). Automatic print function. Tactile keypad. Keys for ON, OFF, LIGHT, ZERO, TARE, NET/GROSS, kg/lb. Full tilt swivel indicator head. 120 VAC adapter included.

BW-60 & BW150 Platform 15-1/2" x 20-1/2" Height 31"
NTEP Legal for Trade 98-085 Class III 3,000 div

Part Number	Capacity	Weight	SKU	List
BW-60DB scale	150 lb x 0.05 lb	39 lb	3890	\$ 745.00
BW-150DB scale	300 lb x 0.1 lb	39 lb	3891	745.00

Options

Wall mount bracket for BW indicator	1 lb	3892	45.00
In use cover for BW indicator	1 lb	3893	30.00

Service Parts

7504-A00-0080 AC adapter 120 VAC	1 lb	3894	42.80
----------------------------------	------	------	-------



DL-150
Bench/Floor



DL Bench/Floor Scale

Battery operated scale that is easy to operate. Keys for ON/OFF, ZERO, TARE, SET, MODE. Kg/Lb switchable. Large liquid crystal display(LCD). Auto power off after inactive period. Auto span calibration and auto zero tracking. Self contained, battery operated (6) 1.5 VDC batteries (Not included). Includes AC adapter 120 VAC, 50/60 Hz, 1 watt.

Overall size 16.5" x 25" x 31"H. 2 year warranty.

NTEP Legal for Trade 08-016 III 3,000 div,

Part Number	Capacity	Platform	Weight	SKU	List
DL-150 scale	150 x 0.05 lb	15.8" x 20.6"	33 lb	2155	\$ 425.00
DL-300 scale	300 x 0.1 lb	15.8" x 20.6"	47 lb	2156	425.00

Prices are subject to change without notice. Please call for current prices.

Other items are available from the manufacturers, please call for prices.



PB Portable Bench Scale

Portable. Easy to carry. Rechargeable or dry cell battery. 6 digit, detachable LCD display with backlight. Keys for: ZERO, TARE, UNIT/PRINT, POWER. Auto power off, Weighing Hold, Backlight ON/OFF, Bright Control, Print Out functions. Auto zero tracking. Symbols for: Stable, Zero, Tare, kg, lb, Low Battery. RS232C interface. Wall mounting bracket. Rechargeable battery (included), 60 hours or (4) C cell batteries (not included). Overall dimensions 14"W x 24.2"D x 3.3"H. NTEP Legal for Trade 11-056

Part Number	Capacity	Platform	Weight	SKU	List
PB-150	150 lb x 0.02 lb	14" x 17.5"	19 lb	1262	\$ 425.00
PB-300	300 lb x 0.05 lb	14" x 17.5"	19 lb	1263	425.00
PB-500	300 lb x 0.1 lb 500 lb x 0.2 lb	14" x 17.5"	19 lb	1264	425.00



PB
Portable Bench Scale
w/ detachable LCD display



MVS1 Bench/Floor/Shipping/Postal Scale

Heavy duty digital shipping and postal scale. LCD display with backlight. Indicator has rugged ABS housing and a 3m coil cord for wall mounting. Keys for ZERO/ON/OFF, TARE, UNIT, PRINT/HOLD. Units: lb, lb:oz, kg. 9 volt battery operated with power adapter included. Standard USB interface can be connected to computer for receiving weight data. Low profile design with checkered steel nonslip platform. Has shipping screw which protects the load cell against damage during shipping. Base has adjustable non slip feet for easy leveling during installation. Overall 12.0" W x 12.0" D x 2.4" H.

Part Number	Capacity	Platform	Weight	SKU	List
MVS1	165 lb x 0.1 lb 75 kg x 0.05 kg	12" x 12"	9.7 lb	6743	\$ 175.00



MVS1
Shipping
Postal



GL Bench Scale

Portable, Read the weight either forward or reverse, ergonomic with convenient carry handle, back light and wide LCD display. High and low limit and alarm settings. Keys for: Zero, Tare, Print, Unit, On/Off. Display for: Zero, Net, Print, LB, Kg, Battery (3 stage). 100-240VAC adapter (4) C batteries (not included). Overall 13.9"W x 23.1" D x 3.4"H. 2 year warranty.

NTEP Legal for Trade

Part Number	Capacity	Platform	Weight	SKU	List
GL-6060L	30/60x0.01/0.02lb	13.9" x 16.8"	16 lb	1579	\$ 400.00
GL-6150L	30/150x0.02/0.05lb	13.9" x 16.8"	16 lb	1580	400.00
GL-6300L	150/300x0.05/0.1lb	13.9" x 16.8"	16 lb	1581	400.00
GL-6500L	250/500x0.1/0.2lb	13.9" x 16.8"	16 lb	1582	420.00



GL-6060L

Prices are subject to change without notice. Please call for current prices.

Other items are available from the manufacturers, please call for prices.

13-01 Pollitt Dr Ext
Fair Lawn NJ 07410
201-797-2718

Totalcomp
Scales & Balances

www.totalcomp.com
sales@totalcomp.com
Fax 201-797-2287



TBWS bench scale



TBW Bench/Floor Scale

Large easy to read 2 inch (52mm) large LCD display with backlight. Stainless steel pan. ABS plastic indicator. Battery provides up to 70 hours of continuous use (without backlight). Standard RS232 interface for use with a computer or printer. Internal battery and AC adapter included. Weighing units: lb, kg, oz. Application modes: Weighing, Counting, Check Weighing, Accumulation. Keys for: UNIT, PCS, G/N, ACC/TTL/PRINT, TARE, ZERO, ON/OFF. Display for: Zero, Net, Print, lb, kg, Battery. 100-240 VAC adapter and rechargeable battery are included. Overall 15.7"W x 25.1"D x 32.6"H. 2 year warranty. IP65

NTEP Legal for Trade

Part Number	Capacity	Platform	Weight	SKU	List
TBW-100	100 lb x 0.02 lb	15.7" x 19.6"	46 lb	7323	\$ 708.00
TBW-200	200 lb x 0.05 lb	15.7" x 19.6"	46 lb	7324	708.00
TBW-500	500 lb x 0.1 lb	15.7" x 19.6"	46 lb	7325	763.00

Service Parts

GH645 Rechargeable battery	4 lb	6114	29.00
----------------------------	------	------	-------



TBWS Washdown Bench scale



TBWS Bench/Floor Scale Washdown

Washdown IP65 protection against dust and liquids. Stainless steel construction. Easy to read 2 inch (52mm) large LCD display with backlight. Battery provides up to 70 hours of continuous use (without backlight). Standard RS232 interface for use with a computer or printer. Internal battery and AC adapter included. Weighing units: lb, kg, oz. Application modes: Weighing, Counting, Check Weighing, Accumulation. Keys for: UNIT, PCS, G/N, ACC/TTL/PRINT, TARE, ZERO, ON/OFF. Display for: Zero, Net, Print, lb, kg, Battery. 100-240 VAC adapter and rechargeable battery are included. Overall 15.7"W x 25.1"D x 32.6"H. 2 year warranty. IP65

NTEP Legal for Trade

Part Number	Capacity	Platform	Weight	SKU	List
TBWS-100	100 lb x 0.02 lb	15.7" x 19.6"	46 lb	7239	\$ 857.00
TBWS-200	200 lb x 0.05 lb	15.7" x 19.6"	46 lb	7240	857.00
TBWS-500	500 lb x 0.1 lb	15.7" x 19.6"	46 lb	7241	897.00

Options

DLP-50 Label printer	3 lb	7238	299.00
----------------------	------	------	--------

Service Parts

GH645 Rechargeable battery	4 lb	6114	47.31
----------------------------	------	------	-------



T4x4-5K
Floor Scale



Package Heavy Duty Floor Scale Base and Indicator

Package includes:

(1)Base rugged with sturdy deck and channel construction, checkered safety tread deck, painted steel construction.

(1)Indicator TRWS LCD

(1)Calibration of base and indicator

NTEP Legal for Trade 16-016 III, 5,000 div Base

NTEP Legal for Trade 13-091 III, 5,000 div Indicator

Part Number	Size	Capacity	Weight	SKU	List
T4x4-5K package	4'x4'x3.75"	5,000 x 1 lb	260 lb	4737	\$ 940.00
T4x4-10K package	4'x4'x3.75"	10,000 x 2 lb	260 lb	4738	940.00
T5x5-5K package	5'x5'x3.75"	5,000 x 1 lb	345 lb	4768	1,067.00
T5x5-10K package	5'x5'x3.75"	10,000 x 2 lb	345 lb	4769	1,067.00



TRSW Indicator
Included with package

Options

4' x 3' Ramp steel safety tread			150 lb	5712	329.00
4' x 4' Ramp steel safety tread			102 lb	5704	595.00
5' x 4' Ramp steel safety tread			218 lb	5726	666.00

Service Parts

TRWS Indicator			7 lb	7667	233.00
IDS950-4 Summing Junction Box			1 lb	3942	100.00
TSB-2.5K load cell for 5K base		2,500 lb	3 lb	2253	295.00
TSB-5K-SE load cell for 10K base		5,000 lb	3 lb	2255	295.00
DBF 1/2-20 beam foot			1 lb	2522	28.00

Prices for Floor scale bases and packages are FOB Factory

Prices are subject to change without notice. Please call for current prices.

Other items are available from the manufacturers, please call for prices.



VX
Standard Floor Scale
w/ T32XW Indicator



OHAUS®

VX Standard Floor Scale

Portable, rugged. 1/8" and 5/16" thick top plate with raised cross hatch surface for added durability. Low profile floor platform scale package. Ideal solution for freight consolidators, forwarders, processing plants resellers, shipping and receiving departments as well as start up businesses. Quick connects and factory calibration allows the floor scale to operate out of the box with minimal setup. Four IP67 nickel plated alloy steel load cells. Side access NEMA4X, IP65 dust and water protected junction box with 25' long cable. Eye bolt mounting holes to allow easier lifting and positioning of the platform.

T32XW: Stainless steel. 6 digit, 7 segment backlit LCD. Raised tactical keys. Built in bidirectional RS232 with manual, continuous and interval printing. Hardware configuration lockout switch. Software included for parts counting mode with selectable sample sizes. Selectable span calibration points. Averaging level, auto zero tracking. Battery saving off, Geo Code geographical gravity calibration adjustment. Software menu lockouts. 120 VAC, 50-60 Hz. Internal AC power. IP66/NEMA4X.

Ships from Columbus Ohio within 3-5 days. Price is FOB Columbus Ohio.
NTEP Legal for Trade 08-069 III 5,000 div

Part Number	Size	Capacity	Weight	SKU	List
VX32XW2500L*	4' x 4' x 4.5"	2,500 x 0.5 lb	259 lb	5534	\$ 3,457.00
VX32XW5000L*	4' x 4' x 4.5"	5,000 x 1 lb	259 lb	5555	3,457.00
VX32XW10000L	4' x 4' x 4.5"	10,000 x 2 lb	349 lb	5557	4,374.00
VX32XW5000X	5' x 5' x 4.5"	5,000 x 1 lb	509 lb	5556	3,957.00
VX32XW10000X	5' x 5' x 4.5"	10,000 x 2 lb	729 lb	5558	4,988.00

* NTEP Legal for Trade

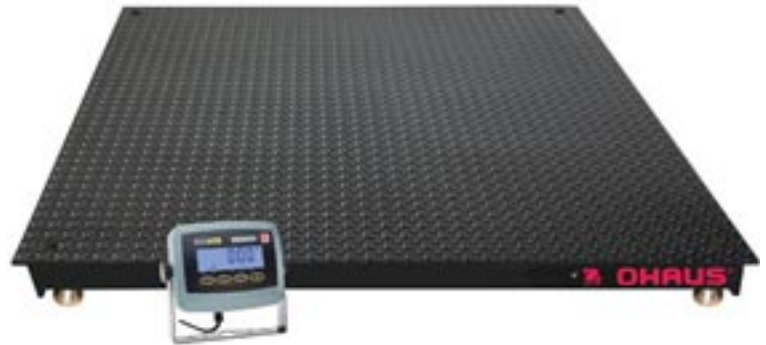

OHAUS®



VN
Standard Floor Scale
w/ T31P Indicator

VN Standard Floor Scale

High quality construction designed to minimize distortion under heavy loads and ensures years of dependable use. Welded steel rib design and thick 0.196"/5mm top plate design provides structural stiffness. Painted tread plate platform top of added slip resistance. Carbon steel eyebolts included for easy installation. Internal structural bracing ensures platform rigidity during everyday use. Four self swiveling ball in cup feet with top access leveling adjustment for easy installation. Available with ramps and mounting feet.

T31P: Large 1" high digit backlit LCD display with a choice of lb or kg. Durable mechanical switch keypad with dedicated Print, Tare and Function keys for quick and easy operation. Selectable power on unit. Counting mode with a minimum Average Piece Weight of 1d. Selectable sample sizes, automatic retention of last sample size used and Average Piece Weight. Counting software can be selected off where Counting Mode is not required. Built in bidirectional RS232C interface for printing or connection to PC. Printing intervals can be set to manual, continuous, on stable weight or an interval between 1 second and 60 minutes. Geographical gravity correction software allows quick adjustment of calibration to local conditions without need for recalibration of the VN Floor Scale. Four wall mounting holes for screw mounting to bench or wall. Wall or table mounting using the included wall mount or bracket for full tilt adjustment of the indicator. Software menu lockouts. 9VDC, 0.5A AC adapter or internal rechargeable sealed lead acid battery, 100 hour typical operation with full charge. Both included.

Ships from Columbus Ohio within 3-5 days. Price is FOB Columbus Ohio.
NTEP Legal for Trade 08-048A1 III 5,000 div

Part Number	Size	Capacity	Weight	SKU	List
VN31P5000L	4" x 4" x 3.5"	5000 x 1 lb	333 lb	4916	\$ 2,240.00
VN31P5000X	5" x 5" x 3.5"	5000 x 1 lb	533 lb	4917	2,694.00

Options

80252565	48" ramp for VN		95 lb	4918	752.00
80252566	60" ramp for VN		140 lb	4919	855.00

OHAUS®

Defender 3000 Drum Scale

Durable portable floor scale designed for industrial applications. Mild steel threaded platform, built in front and back access ramps, four load cells, and the popular T32M indicator, ABS plastic face plate, painted metal rear housing. Includes folding stainless steel cleats to store the 20 ft indicator cord. For quick transport, the base can be rotated on its side using the stainless steel handles and moved around the shop floor using the two integrated high density polyurethane wheels.

Ships from Columbus Ohio within 3-5 days. Price is FOB Columbus Ohio.

Part Number	Size	Capacity	Weight	SKU	List
DFD32M500ES	41.1" x 40.2" x 7.9"	500 x 0.1 lb	110 lb	789	\$ 2,020.00
DFD32M1000ES	41.1" x 40.2" x 7.9"	1,000 x 0.2 lb	110 lb	790	2,020.00
DFD32M2500ES	41.1" x 40.2" x 7.9"	2,500 x 0.5 lb	110 lb	791	2,020.00
DFD32M1000ER	46.9" x 46.3" x 7.9"	1,000 x 0.2 lb	135 lb	792	2,325.00
DFD32M2500ER	46.9" x 46.3" x 7.9"	2,500 x 0.5 lb	135 lb	793	2,325.00

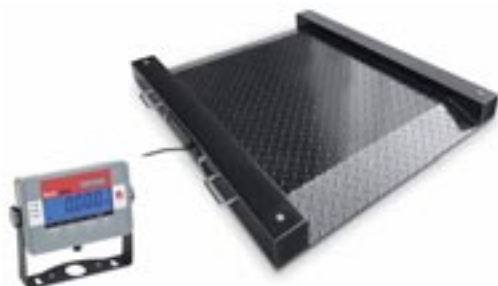

DFD32M2500ES
Drum Scale
w/ T32MC Indicator

doran

PFS7000 Portable Floor Scale Stainless Steel

24" x 24" platform. 7000XLM indicator for fast, accurate digital weights. Pushbutton Zero for fast tare. Indicator height is 40" above the platform and 51" above the floor. 2 handles for easy moving. USDA approved. Washdown safe 304 stainless steel. LB, KG, OZ, LB & OZ weight display. 1 year warranty. 115 VAC, 60 Hz, 8 watts.

NTEP Legal for Trade 91-106, 89-113, III, 3,000 div

Canadian approval AM-5188, S.WA-4398, 3,000 div

Part Number	Capacity	Platform	Weight	SKU	List
7250XL-PFS	250 x 0.1 lb	24" x 24"	200 lb	6496	\$ 4,340.00
7500XL-PFS *	500 x 0.2 lb	24" x 24"	200 lb	6497	4,340.00
71000XL-PFS	1,000 x 0.5 lb	24" x 24"	200 lb	6498	4,340.00

* This model does not have lb & oz weight display capability.



PFS7500XLP
Portable Floor Scale
w/ 7000XLM indicator





TDS Portable Drum Scale

TDS platform is made out of industrial weight heavy duty 1/4" checkered thread steel plate baked powder painted. Two built in folding ramps are low enough to get a hand truck on with ease. Lifting handle and built in wheels for easy moving. Platform uses standard (4) 3 mv/v, 350 ohm load cells and stainless steel signal trim summing junction box. For easy leveling, top bubble level is included. Live rail makes the weighing surface even larger than 36". Select an indicator from our line of indicators and we will calibrate for you. Platform 36" x 36", ramps are 10", overall w/ ramps 44" x 56" x 3"H.

TRWS is Stainless steel, digital weight indicator with backlit LCD display. 6 mechanical switch keys. Applications for: Check Weighing, Accumulation, Over/Under, Animal Weighing. Units for: lb, kg, g, oz, tj, hj. Internal counts: 600,000. Rechargeable battery provide up to 35 hours of continuous use. IP65 housing. RS232 serial port. AC adapter included.

Max div 30,000.

NTEP Legal for Trade 13-091 III 6,000 div

Part Number	Min Height	Capacity	Cell(s)	Weight	SKU	List
TDS-1K	2.00"	1,000 x 0.5 lb	500 lb	150 lb	5247	\$ 1,364.00
TDS-2.5K	2.00"	2,500 x 1 lb	1,000 lb	150 lb	5248	1,364.00
TDS-5K	2.00"	5,000 x 1 lb	2,500 lb	158 lb	5249	1,508.10

TRWS Indicator 5 lb 7667 212.30

Service Parts

Load cell connector, 5 pin	1 lb	6359	31.90
Main board for TRWS	1 lb	6361	140.80
AC adapter for TRWS/TWP/TLI 100-240 VAC to 12 VDC	1 lb	6362	26.18
Battery for TRWS	1 lb	6363	47.08
TRWS front overlay	1 lb	7327	22.00

Option

Tripod for TRWS indicator 3 lb 6287 107.80

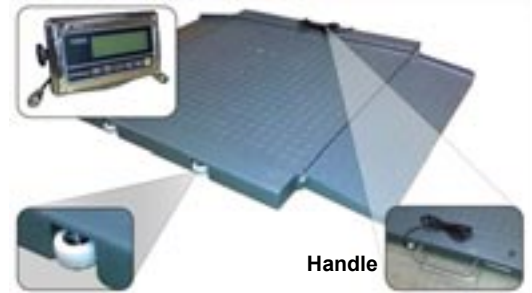

Built in wheels

Handle

TDS



Tripod



**CW250
Floor Scale**



CW250 Portable Floor Scale

Portable and compact scale designed for weighing 55 gallon drums, chlorine cylinders, propane tanks, Freon tanks and other heavy containers. This rugged all aluminum self contained scale has an accuracy of 0.1%. Includes (4)AA 1.2 volt nickel cadmium batteries, charger cable and adapter for charging from 12 VDC or 120 VAC. Batteries will give 200 hours use with full charge. Charging time is 8 hours max. Liquid Crystal weight display has Back Light for use at night. Optional data output is RS232 or 20ma current loop.

Canadian AM-5532

NTEP Legal for Trade 95-024 III 2,000 div

Part Number	Capacity	Weight	SKU	List
15" x 15" x 4" Platform				
CW250-150-1S	150 x 0.05 lb	38 lb	3036	\$ 1,845.00
CW250-300-1S	300 x 0.1 lb	38 lb	2237	1,845.00
CW250-500-2S	500 x 0.2 lb	38 lb	2238	1,845.00
CW250-1000-5S	1,000 x 0.5 lb	42 lb	2239	1,845.00
CW250-1500-5S	1,500 x 0.5 lb	42 lb	2457	1,845.00
CW250-2000-1S	2,000 x 1 lb	42 lb	2240	1,845.00

24" x 24" x 4" Platform

CW250-1000-5	1,000 x 0.5 lb	95 lb	2243	1,695.00
CW250-1500-5	1,500 x 0.5 lb	95 lb	2570	1,695.00

Options

100480 Charger & cable (1) scale	2 lb	1508	160.00
100181 Cast aluminum ramp 24"x24"	30 lb	2247	485.00
100449 Cast aluminum ramp 15"x15"	21 lb	2749	259.00

100183 CW-TW Transport Wheels(2 per platform)	12 lb	2311	175.00
RFX Handheld wireless Indicator	4 lb	6177	995.00

Service Parts

330010 battery pack w/(6) AA NiCad batteries, old style	1 lb	1960	44.00
330158 battery pack w/ (4)AA NiCad batteries	1 lb	2316	39.00
601504 foot for CW250	1 lb	2317	4.25

603091 Load Cell CW250-150/300	6 lb	2318	426.00
603162 Load Cell CW250-500	6 lb	2319	543.00
603048 Load Cell CW250-1000/2000	6 lb	2320	543.00



**RFX
Handheld Wireless Indicator**





RW Portable Floor Scale

Portable low profile floor scale. Platform is made of heavy steel checkered plate with baked powder paint. Two built in ramps. Lifting handles and built in wheels for easy moving. Model 204 Indicator for desk or wall mounting. Standard RS232 output. Overall imensions 32.5"L x 40.5"W x 3.5"H. (6) "C" cells or NiCad batteries or 120 VAC adapter (included) 50/60 Hz.

Part Number	Capacity	Platform	Weight	SKU	List
RW-500	500 x 0.2 lb	32.5" x 30"	105 lb	6004	\$ 2,188.00
RW-1000	1,000 x 0.5 lb	32.5" x 30"	105 lb	6006	2,424.00
Service Parts					
0067-B044-0A cable, load cell connection			1 lb	5993	78.25



Portable

**RW-1000
204 Indicator**



Built-in wheels



Integral handles



SRP-300
w/ Optional Transfer ball top



SRP Bench/Floor Scale

Shipping, Receiving, Manifest Systems, Portion Control. RS232 full duplex serial port. Front panel keys: lb/kg, Zero, Net/Gross, Tare, Print. 120 VAC, 50/60 Hz adapter 6 watt. Overall size (SRP)18" x 18" x 4.8"H. NTEP Legal for Trade 95-034

Part Number	Capacity	Weight	SKU	List
Bright LED display				
SRP-300	300 x 0.1 lb	49 lb	2712	\$ 1,063.00

Options

12" Swivel post for SPL/SRP		2 lb	2713	52.50
18" Swivel post for SPL/SRP		2 lb	2714	62.00
TBT1818 Transfer ball top for SRP		14 lb	2715	350.00



PC-150
Bench Scale



PC Bench Scale

Shipping, Receiving, Manifest Systems, Portion Control, Filling, Packing, Parcel, Letter. Bright LED display. RS232 full duplex serial port. Front panel keys: lb/kg, Zero, Net/Gross, Tare, Print. Compatible with FedEx Ship Manager Software. 120 VAC adapter 9 V, 2 A. Overall size 13" x 13" x 4.4"H. NTEP Legal for Trade 96-000

Part Number	Capacity	Weight	SKU	List
PC-150 scale	0-5 x 0.01 lb	31 lb	1662	\$ 709.00
	5-70 x 0.02 lb			
	70-150 x 0.05 lb			

Options

TBT1313 Transfer ball top		15 lb	1663	295.00
Null modem cable		1 lb	1547	22.00

Service Parts

AD008002 AC adapter for PC-150 9V 2A		1 lb	1630	44.00
--------------------------------------	--	------	------	-------



PD-2Z POS Check Stand Scale

Interface with register or computer. Stainless steel tray. Use as a bench scale. LED display, USB port. Easy to read tilt display. Auto zero tracking. Dual range. AC 120v, 60Hz. Platter size 14.9" x 11". Overall size 15"W x 11"D x 3.1"H
 NTEP Legal for Trade 92-174

Part Number	Capacity	Weight	SKU	List
PD-2Z(15lb)	6 x 0.002 lb 15 x 0.005 lb	15 lb	6979	\$ 529.00
PD-2Z(30lb)	15 x 0.005 lb 30 x 0.01 lb	15 lb	6980	529.00
PD-2Z(60lb)	30 x 0.01 lb 60 x 0.02 lb	15 lb	6981	529.00
PD-2Z(150lb)	60 x 0.02 lb 150 x 0.05 lb	15 lb	6982	559.00

Options

Remote display	5 lb	1502	195.00
7880-PDO-4128 cable 9 pin to RS232 25 pin	1 lb	949	33.00
JPD5 IBM/PC cable 9 pin to RS232 25 pin	1 lb	979	30.00



PD-2Z

POS



7300 Bench Scale

Heavy duty cast construction. UPS Online 6.0 compatible. Stainless steel platform. Bright green LED display. Weight displayed in two units of measure. Front panel keys: ON/OFF, ZERO, UNITS, PRINT. RS232 bidirectional interface. Optional remote display. Optional battery operation. 120 VAC, 50/60 Hz, 8 watts. 14.25"W x 12.25"D x 4"H
 NTEP Legal for Trade 91-149, III, 10,000 div 10 lb and higher
 Canadian AM-4869

Part Number	Capacity	Platform	Weight	SKU	List
7300-2 *	2 x 0.0002 lb	8" x 8"	19 lb	6564	\$ 1,015.00
7300-5 *	5 x 0.0005 lb	8" x 8"	19 lb	6565	1,015.00
7300-10	10 x 0.001 lb	12" x 14"	19 lb	6566	1,015.00
7300-20	20 x 0.002 lb	12" x 14"	19 lb	6567	1,015.00
7300-50	50 x 0.005 lb	12" x 14"	19 lb	6568	1,015.00
7300-100	100 x 0.01 lb	12" x 14"	19 lb	6569	1,015.00
7300-150	150 x 0.02 lb	12" x 14"	19 lb	6570	1,015.00
7300-200	200 x 0.02 lb	12" x 14"	19 lb	6571	1,015.00

* Not NTEP Legal for Trade

Options

57570 Battery operation AC/DC, factory installed	6 lb	6575	95.00
56750-5 Ball top 12"x14" for 50 lb and higher	12 lb	6576	245.00

Service Parts

57520 Battery 12VDC for 7300	4 lb	6577	105.00
57408-7 keypad overlay for 7300	1 lb	6468	60.00



7300 Bench scale UPS

Prices are subject to change without notice. Please call for current prices.

Other items are available from the manufacturers, please call for prices.

13-01 Pollitt Dr Ext
 Fair Lawn NJ 07410
 201-797-2718



www.totalcomp.com
 sales@totalcomp.com
 Fax 201-797-2287



PC400
Portion Control Scale
Shockproof "Quad Spring" platform
with rechargeable battery



doran

PC400 Portion Control Scale

304 **stainless steel** construction for wipedown cleaning not washdown. It can go anywhere with the internal rechargeable battery(included). It will also work on 120VAC power. "Quad Spring" shockproof platform. The electronics are environmentally sealed. Units are lb, kg, g, oz, lb/oz. Modular, replaceable components. Full digital calibration. Keys for ZERO, ON/OFF, UNITS. 4 digit, 0.66" high LCD. RS232 standard. 120 VAC, plug mount transformer with 6 ft. cord (UL/CSA listed) and rechargeable battery, included. Overall dimensions 6.5" W x 8.75" L x 2" H.

NSF Certification National Sanitary Foundation for sanitary food service equipment.
NTEP Legal for Trade 04-039

Part Number	Capacity	Platform	Weight	SKU	List
PC400-02LFT	2.2 x 0.001 lb	6.5" x 6.5"	6 lb	6289	\$ 375.00
PC400-05	5 x 0.002 lb	6.5" x 6.5"	6 lb	6290	375.00
PC400-10	10 x 0.005 lb	6.5" x 6.5"	6 lb	6291	375.00
PC400-20	20 x .01 lb	6.5" x 6.5"	6 lb	2850	375.00

Options

PCOPT06 230 VAC operation	1 lb	6292	60.00
WCB-149 RS232 cable w/9 pin connector	1 lb	6293	42.85

Service Parts

SWI0211 Touch panel	1 lb	8353	89.00
BAT0013 Replacement battery pack for PC400	2 lb	6294	50.00

PCOPT04 carry case PC400	3 lb	6298	100.00
ENC0804 Platter 6.5" x 6.5" for PC400	1 lb	6296	64.20
SUB0531 Foot assembly set of (4) for PC400	1 lb	6297	28.50

XFR0035 AC adapter 115VAC negative center 6' cord for PC400	1 lb	6295	60.00
XFR0039 AC adapter 115VAC positive center 6' cord for PC400*	1 lb	6221	60.00

*Note: PC400 with s/n NPC403000 and higher use the adapter with positive center, stock 6221.

OHAUS®

FD Food Portion Control Scale

All stainless steel, dishwasher safe removable pan. Rugged, multi-use portioning scale. Bright backlit LCD display. Weighing units: lb, decimal and fractional oz, kg, g, lb:oz. Keys are: ON/OFF/ZERO, G/N/T/UNITS, TARGET/MENU, TARE. Indicators for: center of zero, net, tare. Checkweighing mode with 3 LED indicator and audible alarm. Text displays of weigh units. Audible buzzer alerts user when limits are reached. Manual or auto tare. 120VAC adapter included. Internal sealed lead-acid battery with 120 hours charge life. 1 year warranty. 8.8"W X 11.8"D X 2.8"H. Platform size 8.2" x 8.2".

NSF listed/certified
USDA accepted
NTEP Legal for Trade 05-072

Part Number	Capacity	NTEP	Weight	SKU	List
NTEP Legal for Trade					
FD6	15 x 0.002 lb	15 x 0.005 lb	11 lb	5296	\$ 848.00

High accuracy

FD6H	15 x 0.001 lb		11 lb	6418	951.00
------	---------------	--	-------	------	--------

Service Parts

71158350 main board for FD	1 lb	6421	632.00
71169710 keypad function label for FD	0.04 lb	5297	78.00



FD
Portion Control



Prices are subject to change without notice. Please call for current prices.

Other items are available from the manufacturers, please call for prices.



PC500 Portion Control Scale WASHDOWN

Stainless steel. IP66 washdown safe. The PC500 features a soft silicone seal that protects against washdown spray and allows a high level of accuracy. Tackles harsh environments of washdown, food service and industrial applications. 1000% overload "Quad Spring" design. 6 digit, 0.66" high LCD display. Keys for: ON/OFF, Zero, Units. Units are lb, kg, g, oz, or lb:oz. Five way weight display show the same weight in 5 different units. Indicators for motion, low battery, weighing units, and center of zero. 1,000 hour battery life. Battery operated, optional 115V AC adapter with 8' cable. Bi-directional RS-232. Overall dimensions 12.75"L x 9.75"W x 5.26"H. Platter size 8.5" x 8.5"

NSF Certification National Sanitary Foundation for sanitary food service equipment NTEP Legal for Trade 09-032

Part number	Capacity	Weight	SKU	List
PC500-25	25 x 0.01 lb	13 lb	7453	\$ 455.00
PC500-50	50 x 0.02 lb	13 lb	7454	455.00

Options

PC5OPT03 RS-232 Cable w/ 9 pin female		1 lb	7461	50.00
---------------------------------------	--	------	------	-------

Service Parts

XFR0035 AC Adapter 115 V negative center		1 lb	6295	60.00
PCA0374 main board		0.23 lb	2474	150.00
SWI0212 keysheet		1 lb	2499	48.00

LCP22003 load cell PC500-03	3kg	0.89 lb	2496	159.00
LCP22005 load cell PC500-05	5kg	0.89 lb	2516	159.00
LCP22010 load cell PC500-10	8kg	0.89 lb	2517	159.00
LCP22015 load cell PC500-15	15kg	0.89 lb	2518	159.00
LCP22030 load cell PC500-30	30kg	0.89 lb	2519	159.00



PC500-05
Portion control scale



Portion



PPC-300-II Portion Control Scale

ABS with stainless steel platform cover. Large 1.2" LCD display. Checkweighing under/accept/over display. Weighing units: lb, oz, lb-oz, kg. Keys are: ON/OFF, UNITS, TARE, ZERO. Battery (4D) or 120VAC adapter included. Programmable auto off. 1 year warranty. 9.5"W X 11.5 X 4.9"H. Platform size 9.8" x 8".

Part Number	Capacity	Weight	SKU	List
PPC-300-II-4.4	4.4 lb x 0.002 lb	11 lb	2558	\$ 416.00
PPC-300-II-10	10 lb x 0.005 lb	11 lb	2559	416.00
PPC-300-II-22	22 lb x 0.01 lb	11 lb	2560	416.00
PPC-300-II-44	44 lb x 0.02 lb	11 lb	2561	416.00
PPC-300-II-60	60 lb x 0.02 lb	11 lb	2562	416.00



PPC-300-II
Portion Control



PPC-300WP-II Washdown Portion Control Scale

Waterproof IP68. Stainless steel with stainless steel platform cover. Large 1.2" LCD display. Checkweighing under/accept/over display. Weighing units: lb, oz, lb-oz, kg. Keys are: ON/OFF, UNITS, TARE, ZERO. Battery (4D) or 120VAC adapter included. Programmable auto off. 1 year warranty. 9.5"W X 11.5 X 4.9"H. Platform size 9.8" x 8".

Part Number	Capacity	Weight	SKU	List
PPC-300WP-II-4.4	4.4 lb x 0.002 lb	11 lb	1634	\$ 624.00
PPC-300WP-II-10	10 lb x 0.005 lb	11 lb	1635	624.00
PPC-300WP-II-22	22 lb x 0.01 lb	11 lb	1636	624.00
PPC-300WP-II-44	44 lb x 0.02 lb	11 lb	1637	624.00



PPC-300WP-II
Portion Control

Prices are subject to change without notice. Please call for current prices.

Other items are available from the manufacturers, please call for prices.

13-01 Pollitt Dr Ext
Fair Lawn NJ 07410
201-797-2718



www.totalcomp.com
sales@totalcomp.com
Fax 201-797-2287



AW-WLG
Portion Control

Yamato

AW-WLG Washdown Portion Control Scale

Waterproof IP67. ABS with stainless steel platform cover. Large LCD display. Weighing units: lb, oz, lb:oz. Keys are: ON/OFF, UNITS, TARE, HOLD. Battery(4AA) or 120VAC to 15V adapter included. 1 year warranty. 9.4"W X 11.8"D X 2.8"H. Platform size 9.4" x 7.3".

Part Number	Capacity	Weight	SKU	List
AW-WLG-15	0-15 x 0.005 lb	11 lb	30	\$ 394.00
	15-30 x 0.01 lb			
AW-WLG-30	0-30 x 0.01 lb	11 lb	31	394.00
	30-60 x 0.02 lb			



AW-WSM
Portion Control

Yamato

AW-WSM Washdown Portion Control Scale

Waterproof IP67. Stainless steel with stainless steel platform cover. Large 1" LCD display. Weighing units: lb, oz, g. Keys are: ON/OFF, UNITS, TARE/ZERO. 9V battery or 120VAC adapter included. Programable auto off. 1 year warranty. 6"W X 6.8"D X 1.9"H. Platform size 6" x 4.8".

Part Number	Capacity	Weight	SKU	List
AW-WSM-5KG	12 lb x 0.002 lb	11 lb	35	\$ 164.00
	12 lb x 0.05 oz			
	192 oz x 0.05 oz			
	5,500 g x 1 g			



PPC-200W-II
Portion Control

Yamato

PPC-200W-II Washdown Portion Control Scale

Washdown in battery mode. IP65. ABS with stainless steel platform cover. Large 1" LCD display. Checkweighing under/accept/over display. Weighing units: lb, oz, lb-oz, kg. Keys are: ON/OFF, UNITS, TARE, ZERO. Battery (6D) or 120VAC adapter included. Programable auto off. 1 year warranty. 9.1"W X 10.6"D X 6.9"H. Platform size 9.1" x 9.1".

Part Number	Capacity	Weight	SKU	List
PPC-200W-II-4	4 lb x 0.002 lb	11 lb	7045	\$ 548.00
PPC-200W-II-10	10 lb x 0.005 lb	11 lb	7046	548.00
PPC-200W-II-20	20 lb x 0.01 lb	11 lb	7047	548.00
PPC-200W-II-40	40 lb x 0.02 lb	11 lb	7048	548.00

TVS Portion Control Scale WASHDOWN

NTEP Legal for Trade portion control scale featuring **stainless steel** removable platter, IP65 washdown technology. Hand breathable knob design. Weighing units: lb, oz, kg, g, lb-oz. AC or battery. 70 hours of continuous use without backlight. Perfect for any food service in restaurants, bakery, deli, specialty stores, produce stand and farmer's markets. 'D' units have additional rear display for customer use. 9.2"x7.6" platter. 9.6"W x 11.8"D x 5"H. IP65

NTEP Legal for Trade

Part Number	Capacity	Weight	SKU	List
Single display				
TVS-6	6 x 0.001 lb	10 lb	7199	\$ 295.00
TVS-12	12 x 0.002 lb	10 lb	7200	295.00
TVS-30	30 x 0.005 lb	10 lb	7201	295.00
TVS-60	60 x 0.01 lb	10 lb	7202	295.00
Dual Display				
TVS-D-6	6 x 0.001 lb	10 lb	7203	325.00
TVS-D-12	12 x 0.002 lb	10 lb	7204	325.00
TVS-D-30	30 x 0.005 lb	10 lb	7205	325.00
TVS-D-60	60 x 0.01 lb	10 lb	7206	325.00
Service Parts				
YVP1 AC adapter 120VAC		0.21 lb	7347	30.00



TVS



Portion



TVS
Dual display

ACOM

PW-200 ACOM

The ACOM PW-200 Portion Control Scale is a NTEP Legal for Trade portion control scale featuring **stainless steel** removable platter, compact in design and easy to use portion control scale for use in a variety of applications. Weighing units: lbs, oz, kg, g. AC or battery. The PW-200 is perfect for any food service in restaurants, bakery, deli, specialty stores, produce stand and farmer's markets.

NTEP Legal for Trade

Part Number	Capacity	Weight	SKU	List
PW-200(6)	6 x 0.002 lb	6 lb	2538	\$ 221.00
PW-200(15)	15 x 0.005 lb	6 lb	2539	221.00
PW-200(30)	30 x 0.01 lb	6 lb	2540	221.00
PW-200(60)	60 x 0.02 lb	6 lb	2541	221.00
Service Parts				
YPW1 AC adapter 120VAC		0.21 lb	2498	30.00



PW-200





RLP-S
Portion Control Scale



RLP-S Portion Control Scale

Stainless steel. Compact and easy to use. Removable weigh pan for quick and easy cleaning. 6 digit, LED display. Keys for: RE-ZERO, TARE, ON/OFF. Indicators for: Ounces, Grams, Pounds, NET, Center of Zero, Battery Usage. HAACP compliant. AC adapter included. IP68 water and dust resistant. Overall dimensions 9.9"W x 11.4"D x 5.3"H. One year warranty.

NTEP Legal for Trade CC 10-068

Canada AM-5794

Part Number	Capacity	Platform	Weight	SKU	List
RLP-6S	6 x 0.002 lb	9.3" x 7.8"	14 lb	3458	\$ 400.00
RLP-15S	15 x 0.005 lb	9.3" x 7.8"	14 lb	3460	400.00
RLP-30S	30 x 0.01 lb	9.3" x 7.8"	14 lb	3462	400.00
RLP-60S	60 x 0.02 lb	9.3" x 7.8"	14 lb	3467	400.00



PS10
Portion Control Scale

PS Portion Control Scale

PS-10: Multi-Purpose. Easy to clean stainless steel platform. 0.75" LCD, 6 digits with backlight display. Keys for: UNIT, ZERO, TARE/C, ON/OFF. Weighing units are: lb;oz, lb, oz, g. Battery operation for portable weighing. AC adapter (included) or (6) AA Alkaline batteries (not included). Overall dimensions 6.7" x 6.7" x 2.5". Platter size 6.3" x 6.3". 1 year warranty.

PS-20: Multi-purpose. Easy to clean stainless steel platform. 1.2" LCD, 6 digits with backlight. Keys for: ZERO/SET, ON/OFF, TARE/MODE, UNIT. Weighing units are: kg, lb, lb;oz. Battery operation for portable weighing. AC adapter (included) or (6) AA Alkaline batteries (not included). Overall dimensions 12.7" x 10.5" x 3.4". Platter size 10" x 9". 1 year warranty.

Part number	Capacity	Weight	SKU	List
PS10	10 x 0.001 lb	4 lb	7664	\$ 77.50
PS20	20 x 0.01 lb	7 lb	7665	130.00



AP-1 Price Computing Scale

Preset prices are retained in memory for 28 items. Each item has its own separate key for easy entry by pressing a single button. Easy to read bright green tower mounted display has three readouts for Total Price, Weight and Unit Price. Keyboard for entry of values. Keys for ON/OFF, ZERO, TARE, MEM, SAVE, MODE, ADD, *, 1/2, 1/4, TTP CALL, TTP CLP. Auto span calibration with auto zero tracking. Number of transactions display. Optional large tray 17.3" x 10" x 2"H for produce. **Stainless steel** platform size 8.8" x 13.5". Overall size 13.8" x 16.5" x 20"H. 120 VAC, 10 watt. NTEP Legal for Trade 90-007.

Part Number	Capacity	Weight	SKU	List
AP-1-15 Scale	15 lb x 0.005 lb	15 lb	2930	\$ 385.00
AP-1-60 Scale	30 lb x 0.01 lb	15 lb	2625	385.00
Dual range	60 lb x 0.02 lb			
KG version				
AP1-15KG Scale	15kg x 5g	14 lb	1175	385.00
Options				
Produce platter for AP-1		6 lb	5728	90.00
Wet cover for AP-1 for keyboard		3 lb	1142	16.00
Service Parts				
KAPS keypad for AP-1		1 lb	1143	56.00



Computing



AP1
Computing Scale



**LP-1000
Computing Scale**



**LP-1000 w/Pole
Computing Scale**

LP-1000 Label Printing Price Computing Scale

Programmable scale and Auto printing and "Save" for pre-pack. 54 preset keys. 4,000 PLU(Price Look Up). Each PLU can have 5 lines with 80 characters each for 400 characters per PLU. Easy to read bright green display has three readouts for Total Price, Weight and Unit Price. Keyboard for entry of values. Keys for ZERO, TARE, PLU, SAVE, FOR, X, PRT, 1/2, 1/4. PLU data items: Commodity name, message, Item no., tare weight, unit price. Printing items: Commodity name, message, sell by data, unit price, weight, total price, store name & address. Smudge proof thermal label. Optional platter for fish. **Stainless steel** platform size 10" x 15". 16" x 17" x 7.7"H. 120 VAC, 140 watt. NTEP Legal for Trade 92-169

Part Number	Capacity	Memory	Weight	SKU	List
LP-1000-N	30 lb x 0.01 lb	400 Char/4000 PLU	33 lb	7140	\$ 1,395.00

Pole mount display

LP-1000-NP	30 lb x 0.01 lb	400 Char/4000 PLU	34 lb	7142	1,495.00
------------	-----------------	-------------------	-------	------	----------

Options

JCD2 USB to RS232 converter dongle			0.08 lb	2978	60.00
LP1000 Software w/cable			1 lb	2979	95.00
RS232 Interface cable			1 lb	2980	30.00

Service Parts

LST8000 Labels 58 x 30mm 1000/roll 12/case			9 lb	2981	75.00
LST8010 Labels 58 x 40mm 700/roll 12/case			9 lb	2982	75.00
LST8020 Labels 58 x 60mm 500/roll 12/case *			9 lb	2983	75.00
* For Models B & C only.					
LST8030 Labels 58 x 50mm 500/roll 12/case			9 lb	2984	75.00
LST8040 Labels 58 x 60mm 500/roll 12/case			9 lb	2985	75.00

LP-1000 Printhead			49 lb	2711	288.00
2100-LPO-1000 key pad numeric			1 lb	2282	61.60

KL18 keypad for LP-1000			1 lb	2772	80.00
1006-A00-0483 label pickup pin			1 lb	2248	10.00



Prices are subject to change without notice. Please call for current prices.

Other items are available from the manufacturers, please call for prices.



CL5500 Price Computing Scale

30 lb and 60 lb Capacities Available Dual Range 4,000 PLU's w/Direct Ingredient Messages - Max 2,100 Characters LCD Displays 96 Speed Keys (48 keys x 2) High Speed Thermal Printer Ethernet Included/Wireless Optional Same Menu Code System as the CL5000 Multiple Barcode Formats 45 Standard Label Formats Up to 20 Custom Labels Compatible with CL Works Pro Bench: 16(W) x 17(D) x 6.8(H) NTEP Legal for Trade 90-007.

Part Number	Capacity	Weight	SKU	List
CL5500B-60NE bench Dual range	30 lb x 0.01 lb 60 lb x 0.02 lb	36 lb	2089	\$ 2,245.00
CL5500R-60NE w/pole Dual range	30 lb x 0.01 lb 60 lb x 0.02 lb	36 lb	2090	2,345.00
CL5500B-30NE bench Dual range	15 lb x 0.005 lb 30 lb x 0.01 lb	36 lb	2091	2,245.00
CL5500R-30NE w/pole Dual range	15 lb x 0.005 lb 30 lb x 0.01 lb	36 lb	2092	2,345.00



CL5500
Computing Scale

Computing



CL5000 Label Printing Scale

Service parts only for CL5000.

Part Number	Capacity	Weight	SKU	List
Service Parts LST-8051 58mm wide x 100' continuous strip, 12 rolls/case		9 lb	2809	\$ 91.00



CL5000B
Label Printing Scale

Prices are subject to change without notice. Please call for current prices.

Other items are available from the manufacturers, please call for prices.

13-01 Pollitt Dr Ext
Fair Lawn NJ 07410
201-797-2718

Totalcomp
Scales & Balances

www.totalcomp.com
sales@totalcomp.com
Fax 201-797-2287



S2000JR
Price Computing Scale



S2000JR
Price Computing Scale w/pole



S2000JR Price Computing Scale

Soft touch silicon rubber key pad. Backlight LCD display for Weight, Unit Price, Total Price. Auto power off. Keypad 0-9. Lb/kg/oz switchable. Function keys for: POWER, ZERO, TARE, LOW BATTERY, B/L. 3 Direct PLU & 199 indirect PLU's. Rechargeable battery (6V, 3.6Ah). 120V, 60Hz 7 watt. 12hr charging time. 120hr operating time. Platform size 12"W x 8.7"D. Standard type: 12.9"W x 13.6"D x 4.2"H. Pole type: 12.9"W x 15.2"D x 16.2"H.

NTEP Legal for Trade 06-013

Part Number	Capacity	Weight	SKU	List
S2000JR-15L	15 x 0.005 lb	12 lb	7126	\$ 319.00
S2000JR-30L	30 x 0.01 lb	12 lb	7127	319.00
S2000JR-60L	60 x 0.02 lb	12 lb	7128	319.00

S2000JR-15LP w/ pole	15 x 0.005 lb	12 lb	7129	299.00
S2000JR-30LP w/ pole	30 x 0.01 lb	12 lb	7130	299.00
S2000JR-60LP w/ pole	60 x 0.02 lb	12 lb	7131	299.00

Options

Fish platter for S2000JR	2 lb	7138	90.00
KS21 Full body protective cover for S2000JR	1 lb	7237	28.00

Service Parts

LST-8060 67 x 50mm Hi-Speed	9 lb	3421	53.00
Blue Beacon 570/roll, 12 rolls/case			

OT11 Foot	1 lb	3762	13.20
ZS25 Battery S2000JR	1 lb	7508	47.00

KS22 keypad S2000JR	1 lb	3780	26.78
YED2 adapter jack	0.05 lb	3420	24.00
YS21 AC adapter 120 VAC	1 lb	7141	36.00

Laundry Scale

S2000JR-60-LCD	30 x 0.01 lb	22 lb	6038	575.00
dual range & basket	60 x 0.02 lb			

Options

Laundry basket 26.75" x 22" x 11"	14 lb	4901	170.00
-----------------------------------	-------	------	--------



Laundry basket
23" x 26" top, 18" x 22" base
8" high front, 15" high rear



DLP-50
Label printer



DEP-50
Receipt printer

Prices are subject to change without notice. Please call for current prices.

Other items are available from the manufacturers, please call for prices.



S-2000 Price Computing Scale

Low profile price computing scale. Conductive silicone rubber switch with soft touch. Easy to read bright green vacuum fluorescent display for Weight, Unit Price and Total price. Three displays are on the operators side of the scale as well as three displays on the customers side. Keypad 0-9 for entering prices. Function keys for ZERO, TARE, 1/2, 1/4, PREPACK, MW, MR, TARE SAVE, ADD, RECALL. Auto span adjustment and auto zero tracking. Indirect memory backup of up to 800 items. RS232 interface for computerized cash registers only. Not for use with printer or cash register alone. Optional large tray 17" x 11.25" for fish. **Stainless steel** platform size 14.6" x 11". Overall size 15.3" x 14.4" x 5.9"H. 120 VAC, 10 watt. NTEP Legal for Trade 91-141

Part Number	Capacity	Weight	SKU	List
S-2000 scale	30 lb x 0.01 lb	19 lb	2628	\$ 495.00
Dual range	60 lb x 0.02 lb			

Options

Fish platter for S-2000		3 lb	2630	90.00
Wet cover for keyboard for S-2000		1 lb	1569	20.00

Service Parts

PS0C Cas keyboard PBC S-2000		1 lb	2678	48.00
YED1 CAS AC adapter 120VAC/12V/1.25A		1 lb	2728	36.00



S2000
Computing Scale



EB Price Computing Scale

Tilt keyboard and display. Customer side display. Lb/kg switchable. 60 to 300 lb capacity dual range. 24 direct PLU's/176 indirect PLU's. Programmable tare. Auto power off function. Rechargeable battery included. RS232C interface, connect with PC or printer. Large platform for bulk weighing. Optional label and receipt printing. For use with Laundry, Farmers Markets, Retail and Recycling. NTEP Legal for Trade 09-095

Part Number	Capacity	Pan	Weight	SKU	List
EB-60	60 x 0.02 lb	11" x 11"	33 lb	3477	\$ 625.00
EB-150	150 x 0.05 lb	15.75" x 20.3"	46 lb	3478	675.00
EB-300	300 x 0.1 lb	15.75" x 20.3"	46 lb	3479	675.00

Options

Laundry basket 26.75" x 22" x 11"		14 lb	4901	170.00
-----------------------------------	--	-------	------	--------



Laundry basket
23" x 26" top, 18" x 22" base
8" high front, 15" high rear



EB-150
Computing scale

Prices are subject to change without notice. Please call for current prices.

Other items are available from the manufacturers, please call for prices.

13-01 Pollitt Dr Ext
Fair Lawn NJ 07410
201-797-2718

Totalcomp
Scales & Balances

www.totalcomp.com
sales@totalcomp.com
Fax 201-797-2287

TOR * REY



PC-40L
Computing Scale



PC-40L Price Computing Scale

More precise with 0.005 lb resolution. Highly sanitary stainless steel construction. Alphanumeric Liquid Crystal display for Weight, Price per pound and Total price. Three displays are on the operators side of the scale as well as three displays on the customers side. Keypad 0-9 for entering prices. Keys for ON/OFF. (15) direct access memory keys. (100) price memories. 1/2 lb and 1/4 lb price multiplier feature. Includes RS232 serial interface. Rechargeable battery, 200 hrs approx, included. **Stainless Steel** platform size 14"W x 11"D. Overall size 13-15/16"W x 14-3/16"D x 5-5/8"H. 120 VAC. NTEP Legal for Trade 95-041.

Part Number	Capacity	Weight	SKU	List
PC-40L	40 lb x 0.01 lb	19 lb	1269	\$ 414.00
PC-40LT w/ Tower	40 lb x 0.01 lb	26 lb	1270	438.00

Options

Z-21900706 AC adapter for PC40L	1 lb	1540	19.00
---------------------------------	------	------	-------

Service Parts

Z-21900003 rechargeable battery	2 lb	1272	30.00
---------------------------------	------	------	-------



TVP Price Computing Scale

Standard stainless pan, weigh in pounds, kilogram or ounce. 10 PLU for selection. 15 mm LCD display with white LED backlight standard RS232 interface. overall 12" x 10.5" x 4"H. Pan 8" x10.5". Rechargeable battery included. 60 ohms of use without backlight. 120 VAC adapter included. One year warranty.
NTEP Legal for Trade 19-038.

Part Number	Capacity	Weight	SKU	List
TVP-12B	12 lb x 0.002 lb	8.96 lb	1959	\$ 319.00
TVP-30B	30 lb x 0.005 lb	8.96 lb	2017	319.00
TVP-60B	60 lb x 0.01 lb	8.96 lb	2018	319.00

With Pole

TVP-30P	30 lb x 0.005 lb	12 lb	2020	361.00
TVP-60P	60 lb x 0.01 lb	12 lb	2021	361.00

Options

DLP-50 label printer		2.5 lb	993	353.14
----------------------	--	--------	-----	--------



TVP-B
Computing Scale



TVP-P
Computing Scale w/pole



Computing



DLP-300 Label Printing Scale

Price computing scale with label printer. 30 lb and 60 lb capacity. 20,000 PLU'S, 56 speed keys. 32 standard label formats and 67 custom labels. High speed thermal printer. USB and network for easy firmware updates. Multiple barcode formats. PLU editor, label editor, keypad editor. USB, Ethernet, wireless, RS-232C. 120 VAC 50/60HZ overall 15.4"x17.3"x16.5"H. One year warranty
NTEP Legal for Trade 17-054.

Part Number	Capacity	Platform	Weight	SKU	List
DLP-300	30 lb x 0.01 lb 60 lb x 0.02 lb	14.3" x 11.1"	29 lb	2087	\$ 1,589.00

Options

DLP-50 label printer		2.5 lb	993	353.14
----------------------	--	--------	-----	--------



DLP-300
Label Printing Scale



Prices are subject to change without notice. Please call for current prices.

Other items are available from the manufacturers, please call for prices.

13-01 Pollitt Dr Ext
Fair Lawn NJ 07410
201-797-2718

Totalcomp
Scales & Balances

www.totalcomp.com
sales@totalcomp.com
Fax 201-797-2287

Over/Under



CIM-100
Over/Under



CIM In Motion Checkweigher

Mild steel construction, epoxy paint. In-motion conveyor scale. Anti-static polyester fabric conveyor belt. Up to 200 ft. per minute belt speed. Package weight up to 200 lb. 1/2 horsepower AC fixed speed motor 230/460 VAC 3 PH, 50/60 Hz. Must add indicator. Suggest Cardinal 225 or Cardinal 825. Custom software is available. \$ 200/hr minimum (4) hours. 48"L x 24"W x 32"H

Part Number	Capacity	Weight	SKU	List
CIM-100	100 lb x 0.01 lb	200 lb	5251	\$ 14,910.00
CIM-200	200 lb x 0.02 lb	200 lb	5252	14,910.00

Over/Under



CK-10
Over/Under



CK-10 Over/Under Scale

Service parts only for First-Weigh CK-10.

Part Number	Weight	SKU	List
Service Parts			
Display board for CK-10	1 lb	3990	\$ 105.75
Leveling foot for CK-10	1 lb	3994	12.90



TLC
Over/Under



TLC Over/Under Scale

Weighing scale with electronic strain gauge load cell. Over/Under (Hi-Lo) function. Push button TARE. Large(5/8") liquid crystal display(LCD) can be selected to lb or kg. Over/Under mode will give an audible tone above the low set point and below the high set point weight. This means that the tone will only sound when the item on the scale platform is at the correct weight. Self contained, battery operated with (6) size "C" batteries(not included) or AC adapter 9VDC, 300ma output (included). Splash proof construction with **stainless steel** platform size 8-3/4" x 8-3/4". Overall size 9-1/2" x 12-3/8" x 3-1/4"H. USDA Approved.

NTEP Legal for Trade 93-078 III 3,000 div.

Part Number	Capacity	Weight	SKU	List
TLC-060A	6,000 x 2g 12 x 0.005 lb	9 lb	2444	\$ 385.00

Service Parts

Adapter 120VAC to 9VDC, 200ma	1 lb	2446	97.70
-------------------------------	------	------	-------



Prices are subject to change without notice. Please call for current prices.

Other items are available from the manufacturers, please call for prices.



A&D WEIGHING DIVISION

FS-Ki Over/Under Scale

Stainless steel construction. Three resolution levels. Large bright comparator lights. 4 function analog sweep display. 99 item data memory. Programmable Tare. Easy to read backlight LCD display. Weighing units are: lb, kg, lb-oz, oz. RS 232/comparator output option. Optional rechargeable battery. 2 year warranty.

NSF certified

Part Number	Capacity	Pan Size	Weight	SKU	List
FS-6Ki	15 x 0.005 lb	9.8" x 9.8"	24 lb	3574	\$ 1,350.00
FS-15Ki	35 x 0.01 lb	9.8" x 9.8"	24 lb	3575	1,350.00
FS-30Ki	70 x 0.02 lb	15" x 11.8"	24 lb	3576	1,580.00

Options

HC-06i Rechargeable battery pack	1 lb	6786	55.00
FS-C 21.5" Extension column (Only for FE-30Ki)	1 lb	3582	190.00
FS-01i Wall mount bracket	1 lb	3583	185.00
FS-03i RS 232C & Comparator output	1 lb	3584	148.00

Service Parts

FS-D Indicator	1 lb	4005	1,050.00
07:3008855 leveling foot for FSi	0.06 lb	4006	15.00

Load Cells

For use in

LC:156-6K	FS-6Ki	0.57 lb	3369	291.00
LC:156-15K	FS-15Ki	0.57 lb	3370	291.00
LC:156-30K	FS-30Ki	0.57 lb	3371	291.00

Service parts for old version FS-K

Load Cells

For use in

LC:FS6K	FS-6K	3 lb	1144	495.00
LC:FS15K	FS-15K	3 lb	1145	495.00
LC:FS30K	FS-30K	3 lb	1146	495.00



FS-15Ki Over/Under



FS-30Ki Over/Under

Over/Under

Prices are subject to change without notice. Please call for current prices.

Other items are available from the manufacturers, please call for prices.

13-01 Pollitt Dr Ext
Fair Lawn NJ 07410
201-797-2718



www.totalcomp.com
sales@totalcomp.com
Fax 201-797-2287



2200CW
Over/Under



2200CW Over/Under Scale

Expansive 250 product ID database, versatile communications, powerful control options and outstanding PC support software in a simple to use, technologically advanced and extremely rugged package. Quad spring base. Heavy duty 304 stainless steel construction and NEMA 4X classification for washdown protection. 6 digit red LED. Keys for: TARE, GROSS/NET, ZERO, PRINT, UNITS, ACCUM, CLEAR, PROD ID, SET POINT, OVER, UNDER, ENTER, DECIMAL POINT, NUMERIC KEYPAD 0-9. Indicators for net, zero, batt, mot, over, under, accept. Units are lb, oz, kg, g/lb/oz. Two programmable inputs. Two configurable bidirectional RS232 serial ports. Eight digital outputs. 2 year warranty.

NTEP Legal for Trade 06-101 (Indicator)

NTEP Legal for Trade 97-097 (15" x 15")

NTEP Legal for Trade 05-062 (18" x 18", 18" x 24", 24" x 24")

Part Number	Capacity	Platform	Weight	SKU	List
14" column					
2202CW-C14	2 x 0.0005 lb	10" x 10"	21 lb	7301	\$ 1,740.00
2205CW-C14	5 x 0.001 lb	10" x 10"	21 lb	7302	1,740.00
2210CW-C14	10 x 0.002 lb	10" x 10"	21 lb	7303	1,740.00
2225CW-C14	25 x 0.005 lb	10" x 10"	21 lb	7304	1,740.00
2250CW-C14	50 x 0.01 lb	10" x 10"	21 lb	7305	1,740.00
2250CW/12-C14	50 x 0.01 lb	12" x 12"	26 lb	7306	1,855.00
22100CW/12-C14	100 x 0.02 lb	12" x 12"	26 lb	7307	1,855.00
2250CW/15-C14	50 x 0.01 lb	15" x 15"	45 lb	7308	2,100.00
22100CW/15-C14	100 x 0.02 lb	15" x 15"	45 lb	7309	2,100.00
22200CW/15-C14	200 x 0.05 lb	15" x 15"	45 lb	7310	2,100.00
20" column					
2250CW/15-C20*	50 x 0.01 lb	15" x 15"	30/41 lb	7311	2,170.00
22100CW/15-C20*	100 x 0.02 lb	15" x 15"	30/41 lb	7312	2,170.00
22200CW/15-C20*	200 x 0.05 lb	15" x 15"	30/41 lb	7313	2,170.00
22100CW/18S-C20*	100 x 0.02 lb	18" x 18"	11/67 lb	7314	2,445.00
22250CW/18S-C20*	250 x 0.05 lb	18" x 18"	11/67 lb	7315	2,445.00
22500CW/18S-C20*	500 x 0.1 lb	18" x 18"	11/67 lb	7316	2,445.00
22250CW/1824-C20*	250 x 0.05 lb	18" x 24"	30/75 lb	7317	2,645.00
22500CW/1824-C20*	500 x 0.1 lb	18" x 24"	30/75 lb	7318	2,645.00
22250CW/2424_C20*	250 x 0.05 lb	24" x 24"	30/86 lb	7319	2,925.00
22500CW/2424-C20*	500 x 0.1 lb	24" x 24"	30/86 lb	7320	2,925.00
22100CW/2424-C20*	1000 x 0.2 lb	24" x 24"	30/86 lb	7321	2,925.00

*sent in (2) boxes.

Service Parts

2200CW Digital weight indicator	6 lb	7322	875.00
SUB0869 keypad (12)screws 2200CW	1 lb	7018	120.00
SUB0663 keypad (4)screws 2200CW	1 lb	7019	200.00

Options

EXOPT118 RS232 10' cable w/ pigtails	1 lb	6100	100.00
EXOPT148 RS232 10' cable 25 pin D female	1 lb	6228	100.00
EXOPT119 RS232 10' cable 9 pin D female	1 lb	6175	100.00
EXOPT147 External DC power 12VDC	3 lb	6306	266.00
EXOPT136 Stainless steel load cell for 10" base	2 lb	6270	260.00
EXOPT137 Stainless steel load cell for 12" base	2 lb	6283	300.00
EXOPT138 Stainless steel load cell for 15" base	2 lb	6284	300.00
EXOPT115 Remote ZERO switch	1 lb	6260	120.00
EXOPT116 Remote PRINT switch	1 lb	6261	120.00
EXOPT117 Remote UNITS switch	1 lb	6262	120.00

Prices are subject to change without notice. Please call for current prices.

Other items are available from the manufacturers, please call for prices.



4300 Excel Checkweigher Scale

Stainless steel construction. Unique "Quad Spring" base design eliminates most common load cell damage. 6 digit, 0.56" red LED. Keys are: ZERO, PRINT, UNITS, OVER, UNDER. Weighing Units are: g, lb, kg, oz, lb:oz. Indicators are: g, lb, kg, oz, over, accept, under, neg, zero, mot. 3 or 5 zone checkweighing operations. Shock and overload are protected up to 10 times capacity. Rugged touch panel resists moisture and puncture damage. RS232 bi-directional interface. 115 VAC, 50/60 Hz. 2 year warranty. Canadian approved AM-5201 & AM-5241 NTEP Legal for Trade (indicator) 97-038 NTEP Legal for Trade (base) 97-097



Over/Under

Part Number	Capacity	Platform	Weight	SKU	List
4302-C14	2 x 0.0005 lb	10" x 10"	26 lb	6190	\$ 1,650.00
4305-C14	5 x 0.001 lb	10" x 10"	26 lb	3680	1,650.00
4310-C14	10 x 0.002 lb	10" x 10"	26 lb	3681	1,650.00
4325-C14	25 x 0.005 lb	10" x 10"	26 lb	3682	1,650.00
4350-C14	50 x 0.01 lb	10" x 10"	26 lb	3683	1,650.00
4350/12S-C14	50 x 0.01 lb	12" x 12"	30 lb	3684	1,765.00
43100/12S-C14	100 x 0.02 lb	12" x 12"	30 lb	3685	1,765.00
4350/15-C14	50 x 0.01 lb	15" x 15"	45 lb	5412	2,010.00
43100/15-C14	100 x 0.02 lb	15" x 15"	45 lb	5413	2,010.00
43200/15-C14	200 x 0.05 lb	15" x 15"	45 lb	5414	2,010.00

Options

EXOPT118 RS232 Serial Data Output w/ 4 wire shielded cable, 10 ft, pigtail ends	1 lb	6100	100.00
EXOPT119 RS232 Serial Data Output w/ 4 wire shielded cable, 10 ft, 9 pin female D connector	1 lb	6175	100.00
EXOPT148 RS232 Serial Data Output w/ 4 wire shielded cable, 10 ft, 25 pin female connector	1 lb	6228	100.00
EXOPT115 Remote switch for ZERO, non washdown	1 lb	6260	120.00
EXOPT116 Remote switch for PRINT, non washdown	1 lb	6261	120.00
EXOPT117 Remote switch for UNITS, non washdown	1 lb	6262	120.00
EXOPT136 Stainless steel load cell for 10" x 10" base	2 lb	6270	260.00
EXOPT137 Stainless steel load cell for 12" x 12" base	2 lb	6283	300.00
EXOPT138 Stainless steel load cell for 15" x 15" base	2 lb	6284	300.00
EXOPT147 External DC power (12VDC)	3 lb	6306	266.00

Service parts

4300M Digital Weight Indicator only	9 lb	6216	785.00
SUB0438 gasket set(4) holes	1 lb	6263	41.50
SUB0847 gasket set(12) holes	1 lb	6264	41.50
SUB0823 footswitch w/quick disconnect	1 lb	6227	242.85



4300 Checkweigher Over/Under

Prices are subject to change without notice. Please call for current prices.

Other items are available from the manufacturers, please call for prices.

13-01 Pollitt Dr Ext
Fair Lawn NJ 07410
201-797-2718



www.totalcomp.com
sales@totalcomp.com
Fax 201-797-2287



TCM2 Counting Scale

Your perfect solution for your everyday high accuracy counting. The TCM2 is a single platform counting scale and includes a free connection for a second platform. The second platform can be added at any time and have either a larger or smaller capacity. This is important if you are counting large amounts such as on a pallet which cannot be placed on the main platter. Large 0.7" LCD blue back lighted display. TCM2 has 256 items memory locations for individual piece weight, tare weight and units (lb or kg). Three displays for WEIGHT, PIECE WEIGHT, COUNT. Front panel audible and tactile feedback keys for: ON/OFF, 0-9 KEYPAD, NET/GROSS, SCALE 1-2, UNIT, PCS, PcWt, ST.UTP, RC.UTP, PRINT, TARE, CLEAR, ENTER, EXIT. Annunciators for: Zero, Stable, Tare, Gross, Net, Print, Kg, Lb, Scale, 1-2, CHG, AC. Stainless steel platter 9" x 13" with spill guard. Front bubble level and adjustable rubber feet for easy leveling. Rechargeable battery included. Battery operating time is 60 hours. Time and date, RS232 output. 110 VAC power supply.



TCM2 Series
Counting Scale



Optional Printer

Optional second Base

Part Number	Capacity	Pan	Weight	SKU	List
TCM2-15	15 x 0.0005 lb	9" x 13"	14 lb	5902	\$ 448.00
TCM2-30	30 x 0.001 lb	9" x 13"	14 lb	5903	448.00
TCM2-60	60 x 0.002 lb	9" x 13"	14 lb	5904	448.00

Service Parts

Keypad board for TCM2			1 lb	4375	107.00
Keypad overlay for TCM2			1 lb	4376	47.60
Display board for TCM2			1 lb	4422	142.00
Display overlay for TCM2			1 lb	4423	41.70
Main board for TCM2			1 lb	4432	261.00
AC adapter 12 VDC/600mA For TCM2			1 lb	4433	57.00
Battery lead acid			4 lb	6114	29.00
Stainless steel platter for TCM2			3 lb	4439	97.30
Plastic platter for TCM2			2 lb	4440	50.00
Leveling foot, each set of (4) for TCM2			1 lb	4518	26.60



A&D WEIGHING DIVISION

Counting

HCi Counting Scale

Simple and easy operation with high performance counting function. Keys are: ON OFF, ZERO, KEYBOARD TARE, TARE, ID, KEYBOARD, SAMPLE, STORE UNIT WEIGHT, ENTER, PRINT, TOTAL, M+, *, RESET, 0-9, C. 7 segment LCD. Navigation system with LED for easy and simple operation. Up to 99 unit weights ID memory function. Auto power OFF function. Automatic Counting Accuracy Improvement (ACAI). Audible Weighing Assist (AWA) beeping function. Detachable display unit. Comparator function with "HI", "OK", "LO" display. Accumulation function. Universal Flex Coms function. Full digital calibration function. 120 VAC AC adapter. Platform size 11.8" x 8.3". Overall size 12.4"W x 13"D x 5"H.

Part Number	Capacity	Weight	SKU	List
HC-3KA	6 x 0.001 lb	11 lb	3212	\$ 560.00
HC-3Ki	6 x 0.001 lb	11 lb	6780	820.00
HC-6Ki	15 x 0.002 lb	11 lb	6781	820.00
HC-15Ki	30 x 0.005 lb	11 lb	6782	820.00
HC-12KA	30 x 0.005 lb	11 lb	3214	560.00
HC-30Ki	60 x 0.01 lb	11 lb	6783	820.00

Options

HC-03i RS 232C	1 lb	6784	92.00
HC-04i RS 232C Relay output	1 lb	6785	115.00
HC-06i Rechargeable Battery Pack	1 lb	6786	55.00
HC-08i Extension cable	1 lb	6787	68.00

Service Parts

07:1000409 platform support HCi	1 lb	6742	21.00
07:4011266A adjustable foot	0.05 lb	2986	21.86



HC-6Ki Counting Scale

Counting



A&D WEIGHING DIVISION

HD Counting Scale

High performance, affordable, great features. A version is for simple operation w/one LCD display. B version has 10-key pad for entry of tare weight, piece weight and sample size w/three LCD displays for WEIGHT, UNIT-WEIGHT, COUNT. Key functions are /TOTAL, SAMPLE, ENTER/M+PRT, MODE/RESET, ZERO, TARE. Counting resolution 1/240,000 max count 120,000. Automatic Counting Accuracy Improvement. Optional rechargeable battery pack. Standard with 120 VAC AC adapter and (6) 'C' batteries. Platform size 8.5" x 11.57"(HC), 11.81" x 14.96"(HD). Overall size is 12.6" x 13" x 4.65"H(HC), 16.18" x 18.5" x 4.72"H(HD).

Part Number	Capacity	Weight	SKU	List
Detachable display head				
HD-12KA	30 x 0.005 lb	26 lb	3221	\$ 1,190.00
HD-30KA	60 x 0.01 lb	26 lb	3222	1,190.00
HD-60KA	120 x 0.02 lb	26 lb	3223	1,190.00
HD-12KB w/keypad	30 x 0.005 lb	26 lb	3224	1,320.00
HD-30KB w/keypad	60 x 0.01 lb	26 lb	3225	1,320.00
HD-60KB w/keypad	120 x 0.02 lb	26 lb	3226	1,320.00

Options

HD-03 RS232 output for HD Series	1 lb	3227	148.00
HD-04 Comparator output for HD Series	1 lb	3228	210.00
HD-05 20ma current loop output for HD Series	1 lb	3229	145.00
HD-06 Carrying handle for HD Series	2 lb	3230	105.00

Service Parts

TB:662 AC adapter 120VAC	1 lb	1305	45.00
TB:164 AC adapter 220VAC	1 lb	4612	65.00



HD-12KA Counting Scale

Prices are subject to change without notice. Please call for current prices.

Other items are available from the manufacturers, please call for prices.

13-01 Pollitt Dr Ext
Fair Lawn NJ 07410
201-797-2718



www.totalcomp.com
sales@totalcomp.com
Fax 201-797-2287



A&D WEIGHING DIVISION



FCi
Counting Scale

FCi Counting Scale

High resolution: FC-Si has 1/5,000,000 internal and 1/20,000 display. FC-i has, 1/1,000,000 internal and 1/10,000 display. Four bright easy to read fluorescent displays for weight, average piece weight, piece count, item code, tare weight and accumulator. Durability for use in industrial environments. 500 Memories (with 6 digit ID) for unit weights, tare weights, alphanumeric names/codes (12 digits), accumulators & comparator limits. Standard RS232 interface with optional 2nd and 3rd RS232. Optional remote scale connector. Optional NiMH battery packs runs for up to 10 hours between charges. 120VAC. 12.5"W x 17"D x 3.66"H

Part Number	Capacity	Pan	Weight	SKU	List
FC-500Si	1 x 0.00005 lb	5" x 5"	19 lb	6129	\$ 2,040.00
FC-5000Si	10 x 0.0005 lb	6.5" x 6.5"	19 lb	6130	2,040.00
FC-500i	1 x 0.0001 lb	6" x 8"	19 lb	6523	1,480.00
FC-1000i	2 x 0.0002 lb	6" x 8"	19 lb	6524	1,480.00
FC-2000i	5 x 0.0005 lb	11" x 11.8"	19 lb	6525	1,480.00
FC-5000i	10 x 0.001 lb	11" x 11.8"	19 lb	6131	1,480.00
FC-10Ki	20 x 0.002 lb	11" x 11.8"	19 lb	6132	1,480.00
FC-20Ki	50 x 0.005 lb	11" x 11.8"	19 lb	6133	1,480.00
FC-50Ki	100 x 0.01 lb	11" x 11.8"	21 lb	6134	1,480.00

Options

FC-02i Rechargeable NiMH battery pack for FCi	5 lb	6135	480.00
FC-03i Second & third RS232 for FCi	1 lb	6136	270.00
FC-04i RS232/Comparator/relays/Buzzer for FCi Can install either FC-03i or FC-04i	1 lb	6137	320.00
FC-05i Remote scale connection for FCi	1 lb	6138	175.00
CC:110 Carrying & storage case for FCi	5 lb	6526	155.00

Service parts

08:200776A keysheet	1 lb	6140	29.00
PZ:3822A display board	1 lb	6078	559.00
07:3005802A display filter	1 lb	6079	14.00
TB:136 Adapter 120VAC	2 lb	3000	43.00
TB:137 Adapter 220VAC	1 lb	3001	65.00



CCT Counting Scale

Ideal for use in warehouses, manufacturing processes, and production facilities, the CCT bench counting scale is practical for any counting application. Quickly check the number of pieces in a carton or container, helps reduce waste when filling orders or packaging shipments. Optional USB interface simplifies data communication. Rechargeable battery included for operation almost everywhere. Programmable auto power-off to save energy. Parts counting optimization automatically refines piece weight as parts are added. Built in memory for storing products and settings. Intuitive software is user-friendly and keeps track of the count, automatically optimizing the unit weight for greater accuracy. The programmable backlit display can be customized to be "always on", "always off" or to light only weighing. Platform 8.3" x 11.8".

Part Number	Capacity	Nominal	Weight	SKU	List
CCT 4	8 x 0.0002 lb	4 kg x 0.1 g	11 lb	2506	\$ 605.00
CCT 8	16 x 0.0005 lb	8 kg x 0.2 g	11 lb	2507	605.00
CCT 16	35 x 0.001 lb	16 kg x 0.5 g	11 lb	2508	605.00
CCT 32	70 x 0.002 lb	32 kg x 1 g	11 lb	2509	605.00
CCT 48	100 x 0.005 lb	48 kg x 2 g	11 lb	2510	605.00
Ultra High Resolution					
CCT 8UH	16 x 0.0001 lb	8 kg x 0.05 g	11 lb	2511	730.00
CCT 16UH	35 x 0.0002 lb	16 kg x 0.1 g	11 lb	2512	730.00
CCT 32UH	70 x 0.0005 lb	32 kg x 0.2 g	11 lb	2513	730.00
CCT 48UH	100 x 0.001 lb	48 kg x 0.5 g	11 lb	2514	730.00

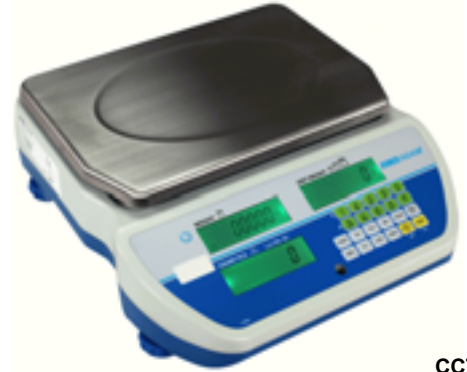

CCT Counting Scale

Counting



GFC Floor Counting Scale

GFC counting scales simplify complex counting applications involving heavier loads. The GFC indicator can be mounted on the enclosed pillar or used on the bench depending on your viewing needs. Splash proof keypad, backlit 3 x 6 inch LCD. Keys for: SAMPLE, MEMORY PLUS, UNIT/WEIGHT/UNIT, PST/ZERO, ON, OFF. Auto calibration through keypad, overload indicator, preset count with alarm, low battery indicator, auto power off. Platform size 15.7" x 19.7". Overall size 16" x 24" x 34". 9 VDC rechargeable battery, 70 hours of operation. 120VAC Power supply adapter supplied as standard. Two year warranty.

Part Number	Capacity	Weight	SKU	List
GFC165a	165 lb x 0.01 lb	34 lb	6965	\$ 1,075.00
GFC330a	330 lb x 0.02 lb	34 lb	6966	1,075.00
GFC660a	660 lb x 0.05 lb	34 lb	6967	1,210.00

Service Parts

302409160 adapter 120 VAC	1 lb	252	53.33
---------------------------	------	-----	-------



GFC Series Floor Counting Scale

Prices are subject to change without notice. Please call for current prices.

Other items are available from the manufacturers, please call for prices.

Counting



SC10P
Counting Scale



SC Counting Scale

Counting scale with precise 5 digit unit weight calculation. 1,000 items of unit weight memory. Kilogram/pound conversion. Built in count comparator. Bright and easy to read green fluorescent displays for Weight, Unit Weight and Count. Three methods for entry of piece weight; with the keyboard, by weighing the actual sample or with internal memory and tare values. High internal counting resolution 1/100,000. Count comparator function. Count add up function. Keys for ENTRY, SAMPLE, CALL, STORE, M+, TOTAL, ZERO, TARE, g/lb, MODE, SET, PRINT, and 0-9 numeric. Platform size 14.6" x 11". Overall size is 15.3" x 14.4" x 5.9"H. 120 VAC, 10 watt.

Part Number	Capacity	Weight	SKU	List
SC-05P	10 lb x 0.002 lb	19 lb	2632	\$ 450.00
SC-10P	25 lb x 0.005 lb	19 lb	2633	450.00
SC-25P	50 lb x 0.01 lb	19 lb	2634	450.00

Service Parts

KSC2 keypad SC series, bottom cable, old version	0.27 lb	2642	57.14
KSC1 keypad SC series, top cable, new version	0.27 lb	2643	57.14



EC Counting Scale

Counting scale with accurate count and high resolution. Easy to read LCD display and blue backlight. Soft tact keyboard. Function keys for ON/OFF. Units of measure displays kg, g, or lb. 100 unit weight memory and accumulation functions. RS232C interface. Rechargeable battery with 80 hours continuous use, 12 hour recharge time. AC adapter included. Platter size 12"W x 8.74"D. Overall size 13"W x 13.6"D x 4.2"H

Part Number	Capacity	Weight	SKU	List
EC-6	6 x 0.0002 lb	12 lb	7441	\$ 395.00

Options

YEC1 adapter 12VDC 800 ma must be programmed for EC	1 lb	7476	33.00
--	------	------	-------



EC Series
Counting Scale



EC2 Counting Scale Dual Channel

Designed with CAS reliability, the EC-2 Series Counting Scale stands alone its field. High accuracy and simple to use. Optional label or receipt printer. Great for use in manufacturing, parts shops, hardware stores, etc. Easily Connects Second Platform to Expand Capacity. Save Up to 200 Presets. Up to 4 External Devices can be used simultaneously. Lb/kg or Lb/g Switchable

Part Number	Capacity	Weight	SKU	List
EC2-6	6 x 0.0002 lb	10 lb	297	\$ 415.00
EC2-15	15 x 0.0005 lb	10 lb	298	415.00
EC2-30	30 x 0.001 lb	10 lb	299	415.00
EC2-60	60 x 0.002 lb	10 lb	300	415.00



EC-2 Series

Prices are subject to change without notice. Please call for current prices.

Other items are available from the manufacturers, please call for prices.



7600 Counting Scale

Heavy duty cast construction. Full numeric keyboard for entry of Tare weight, 6 digit ID, Sample quantity and Average piece weight. Easy one button counting. Auto sample update for improved accuracy. 1 part in 1 million internal resolution. Bright green LED display with time and date. Weight is displayed in two different units of measure and count. Keys for ZERO, SAMPLE SET, GROSS/NETT, TARE, PIECE WEIGHT, KEYPAD TARE, 0-9 KEYPAD, BASE, UNITS, PRINT, CLEAR, %, CHECK, ON/OFF, ENT. RS232 base for larger or smaller loads. Optional battery for portable operation. 120VAC, 15.5"W x 14"D x 5.25"H. NTEP Legal for Trade 91-149

Part Number	Capacity	Pan	Weight	SKU	List
7600-2	2 x 0.0002 lb	8" x 8"	17 lb	6554	\$ 1,225.00
7600-5	5 x 0.0005 lb	8" x 8"	17 lb	6555	1,225.00
7600-10	10 x 0.001 lb	12" x 14"	17 lb	6556	1,225.00
7600-20	20 x 0.002 lb	12" x 14"	17 lb	6557	1,225.00
7600-50	50 x 0.005 lb	12" x 14"	17 lb	6558	1,225.00
7600-100	100 x 0.01 lb	12" x 14"	17 lb	6559	1,225.00
7600-150	150 x 0.02 lb	12" x 14"	17 lb	6560	1,225.00
7600-200	200 x 0.02 lb	12" x 14"	17 lb	6561	1,225.00

Options

57570 Battery pack, factory installed, AC/DC	6 lb	6551	195.00
57834 Remote base option Dual scale counting	1 lb	6562	375.00
48445 Base connector kit*	1 lb	6581	33.00

Service Parts

57520 12VDC Battery pack	4 lb	6553	105.00
57512-3 display board	1 lb	6659	154.00

*Needed w/ Remote base option when connecting to a base that is not a PA model.



7600
Counting Scale

Counting



7500 Counting Scale

Easy one button counting. Auto sample update for improved accuracy. 1 prt in 1 million internal resolution. Bright green LED display Weight is displayed in two different units of measure and count. Keys for: ZERO, SAMPLE SET, UNITS, PRINT. Optional battery for portable operation. RS232 bidirectional interface for printers, data collection or manifest systems. 120VAC, 15.5"W x 14"D x 5.25"H. NTEP Legal for Trade 91-149

Part Number	Capacity	Pan	Weight	SKU	List
7500-2	2 x 0.0002 lb	8" x 8"	17 lb	6543	\$ 1,125.00
7500-5	5 x 0.0005 lb	8" x 8"	17 lb	6544	1,125.00
7500-10	10 x 0.001 lb	12" x 14"	17 lb	6545	1,125.00
7500-20	20 x 0.002 lb	12" x 14"	17 lb	6546	1,125.00
7500-50	50 x 0.005 lb	12" x 14"	17 lb	6547	1,125.00
7500-100	100 x 0.01 lb	12" x 14"	17 lb	6548	1,125.00
7500-150	150 x 0.02 lb	12" x 14"	17 lb	6549	1,125.00
7500-200	200 x 0.02 lb	12" x 14"	17 lb	6550	1,125.00

Options

57570 Battery pack, factory installed, AC/DC	6 lb	6551	195.00
--	------	------	--------

Service Parts

57520 12VDC Battery pack	4 lb	6553	105.00
57512-3 display board	1 lb	6659	154.00



7500
Counting Scale

Prices are subject to change without notice. Please call for current prices.

Other items are available from the manufacturers, please call for prices.

13-01 Pollitt Dr Ext
Fair Lawn NJ 07410
201-797-2718

 **Totalcomp**
Scales & Balances

www.totalcomp.com
sales@totalcomp.com
Fax 201-797-2287

OHAUS®

Ranger 3000 Counting Scale

ABS housing, **stainless steel** platform, numeric keypad, upfront level indicator, 30 item library. Weighing modes: weighing and parts counting with auto optimization. 3 color LED checkweighing lights, Accumulation, 120VAC power or rechargeable battery(included) 210 hour. RS232 output, auto print setting, auto shut-off.



Ranger 3000

Part Number	Capacity	Pan	Weight	SKU	List
RC31P1502	3 x 0.0001 lb	8.9" x 11.8"	12 lb	8011	\$ 1,075.00
RC31P3	6 x 0.0002 lb	8.9" x 11.8"	12 lb	8012	1,075.00
RC31P6	15 x 0.0005 lb	8.9" x 11.8"	12 lb	8013	1,075.00
RC31P15	30 x 0.001 lb	8.9" x 11.8"	12 lb	8014	1,075.00
RC31P30	60 x 0.002 lb	8.9" x 11.8"	12 lb	8015	1,075.00

Options

30037446 PCBA kit, Second Platform	1 lb	3010	204.00
30037447 Ethernet kit	1 lb	7968	204.00
30037448 RS232 kit	1 lb	7969	204.00
30037449 USB kit	1 lb	3819	204.00
30064203 SF40A Dot Matrix printer, includes RS232 cable	2 lb	1754	1,303.00
80500525 cable RS232 IBM 9 pin male to female	1 lb	3047	254.00
80850080 WinWedge software	1 lb	2436	702.00

Counting

OHAUS®

EC Counting Scale

Economical, fast and designed for accurate operation. 1/600,000 resolution. Weighing units: lb, kg. Keys are: TARE, SAMPLE, APW, ZERO, PRE-SET TARE, M+, CANCEL. Indicators for: center of zero, tare, low sample weight, low APW, accumulation, Low batt. 3 window 6 digit 7 segment backlit LCD with 0.75" characters. External calibration with user selectable weight. 80 hours continuous use with 12 hour recharge time. 120VAC adapter, Internal rechargeable lead acid battery included. 1 year warranty. Platform 12.8"W x 13"D x 4.5"H



EC Counting Scale

Part Number	Capacity	Pan	Weight	SKU	List
EC3	6 x 0.0002 lb	11.8" x 9"	12 lb	4770	\$ 395.00



Ranger 4000 Counting Scale

Sturdy cast aluminum housing for tough industrial weighing. 1,500,000 internal count, 30 item library. Weighing modes: weighing, part counting with optimization, check weighing and accumulation. LCD display, 3 color check weighing LEDs. 120 VAC power or rechargeable battery (included). RS232 output, **stainless steel** platform, up front level indicator, adjustable leveling feet, auto-print settings. Indicators for: stability, overload, underload and low battery. Auto tare, Auto shut-off.

Part Number	Capacity	Pan	Weight	SKU	List
RC41M3	6 x 0.0002 lb	8.9" x 11.8"	16 lb	8007	\$ 1,295.00
RC41M6	15 x 0.0005 lb	8.9" x 11.8"	16 lb	8008	1,295.00
RC41M15	30 x 0.001 lb	8.9" x 11.8"	16 lb	8009	1,295.00
RC41M30	60 x 0.002 lb	8.9" x 11.8"	16 lb	8010	1,295.00

Options

30037446 PCBA kit Second Platform			1 lb	3010	204.00
30037447 Ethernet kit			1 lb	7968	204.00
30037448 RS232 kit			1 lb	7969	204.00
30037449 USB kit			1 lb	3819	204.00
30064203 SF40A Dot Matrix printer, includes RS232 cable			2 lb	1754	1,303.00
80500525 Cable to IBM 9 pin serial			1 lb	3047	254.00
80850080 WinWedge software			1 lb	2436	702.00



Range 4000



**C-30
Counting Scale**



C Counting Scale

1/300,000 resolution. Portable, with built-in battery pack. Includes second scale input port for remote base. Sleep mode for extended battery life. Preset count and weight limits, LCD display with backlight. 0.75" high. Units: lb, kg. 15,000 weight divisions. Color-coded key pad and vinyl dust cover. Memory accumulators, weight and piece weight up to 5 digits, count up to 6 digits. 115 VAC 50/60Hz, 11.75"W x 12.63"D x 4.25".

Part Number	Capacity	Platform	Weight	SKU	List
C30	30 x 0.002 lb	8.25" x 11.38"	13 lb	5245	\$ 624.00
C65	65 x 0.005 lb	8.25" x 11.38"	13 lb	5246	624.00
C100	100 x 0.01 lb	8.25" x 11.38"	13 lb	5243	624.00

Service Parts

6540-1123 Foot leveling 3/8-16x1-1/4"	0.07 lb	5250	23.25
---------------------------------------	---------	------	-------



Supercount

Service parts only for supercount

Part Number	Weight	SKU	List
Service Parts			
404611 keypad, SC	1 lb	6056	\$ 759.09
409250-02 keypad, Supercount II	1 lb	6081	380.23



TBS-300 w/ 24" x 24" base
Baggage Scale



Baggage Scale Kit

This baggage scale indicator kit consists of

- (2) Remote digital weight displays, panel mountable.
- (1) Electronic control unit, high impact plastic, contains power supply and A/D.
- (2) Switches for LB/KG and ZERO/ON/OFF for remote mounting, includes cables for switches.

The remote displays have 0.56" high LEDs, bezels for panel mounting, and 10 ft of heavy duty data cable that connects to the control unit. The indicator kit is factory set up for use with a 300kg 2mv/v load cell. The scale base offered below is set up for the indicator kit.



TBS Indicator

Part Number	Capacity	Weight	SKU	List
TBS-300 Indicator kit	300 x 0.5 lb	10 lb	537	\$ 819.00

Bases Select the base below for use with the indicator kit above

24" x 24" Platform x 5.25" High	Capacity	Weight	SKU	List
TPB-2424-500-SS	500 lb	120 lb	3947	1,905.00

Baggage



64 Baggage scale
24"x24" base
Displays for both agent and passenger



Baggsge

64 Baggage Scale

This baggage scale consists of
 (1) 24" x 24" x 5"H Stainless steel platform with black painted steel base.
 (2) Digital weight displays, panel mounted, with 10' cable each.
 Agent display is weight readout and pushbuttons for ZERO, LB/KG, and PRINT.
 Passenger display is weight readout only.
 Both displays have 0.56" high LEDs, stainless steel bezels for panel mounting, and 10 ft of heavy duty data cable that connects to the scale base. Bezels are 7.25"W x 5.25"H and have (4) mounting holes. Cutout necessary is 5.75"W x 3.5"H. RS232 interface using DB-9 connector. 110VAC 50/60 Hz. Two year warranty.
 NTEP Legal for Trade 98-013

Part Number	Capacity	Weight	SKU	List
64-2424 Baggage scale	500 x 0.1 lb	90 lb	3298	\$ 2,395.00

Service Parts

57409-8 Overlay w/button for 64		1 lb	2688	50.00
49737-6 Level foot 2" dia x 1/2-20		1 lb	310	30.00

Prices are subject to change without notice. Please call for current prices. Other items are available from the manufacturers, please call for prices.



DBS Baggage Indicator

Stainless steel face plate. Outstanding durability and reliability. 6 digit, 0.56" high red LED display. Damage to the electronics from electrostatic discharge generated by the dry airport environment is prevented through advanced electronics design, backed up with extensive testing and decades of field proven reliability. Baggage weight is easily read from up to 20 ft on the large and bright LED display. When baggage is placed on the scale base, the displayed weight quickly stabilizes on the main and remote display to support fast passenger check in. The entire scale electronics is contained in the panel mount Main Display. No additional electronics control box to install inside the counter. Simply install the Main and Remote Displays into counter cutouts and connect the foolproof, keyed and locking cables through the counter, strain reliefs ensure that once the cables are connected, they stay connected. For use with scale base ordered separately. Load cell in base should be 2 or 3 mv/v output. Keys for: ZERO (ON/OFF), UNITS. Units are lb or kg. Indicators for: lb, kg, NEG, ZERO, MOT. Bi-directional RS-232. Panel mount display cut out size is 6.5" x 3.3" x 1.75" deep. 115 VAC 60Hz wall mount transformer. UL/ULc (230 VAC optional). 1 year parts and labor. NTEP Legal for Trade 05-061



**DS100
Baggage Indicator**



Part Number	Capacity	Weight	SKU	List
DS100BMR Indicator Baggage Kit	300 x 0.5 lb	8 lb	302	\$ 600.00

Select one base for use with indicator kit above.



**DS100
Remote Display**

Baggsge



DMS Series Mild Steel Scale Bases

Heavy gauge steel construction. All square tube construction. Seven overload stops provide 250% protection shielding the load cell from damaging shock. Royal blue Epoxy paint. Four adjustable feet and a bubble level to allow precise leveling in your work area. Two year warranty. NTEP Legal for Trade 05-062



**DMS Series
Mild Steel Scale Bases**



Part Number	Capacity	Load Cell	Weight	SKU	List
24 x 24 Platform x 5.25" high					
DMS5250	250 lb	1260-150kg	83 lb	6861	\$ 950.00
DMS5500	500 lb	1260-300kg	83 lb	6862	950.00
DMS51000	1000 lb	1260-500kg	83 lb	6863	950.00

Prices are subject to change without notice. Please call for current prices.

Other items are available from the manufacturers, please call for prices.

13-01 Pollitt Dr Ext
Fair Lawn NJ 07410
201-797-2718



www.totalcomp.com
sales@totalcomp.com
Fax 201-797-2287



Hazardous Floor Base

Hazardous

Hazardous Floor Base

High performance powder coated heavy duty floor scale for hazardous environment. Already configured with FM Approved summing box, load cells and hazardous home run cable. Standard features include: Top access FM Approved signal trim junction box. 20ft blue jacket hostile environment load cell cable. 4 NTEP FM Approved alloy steel shear beam load cells. Heavy powder coated diamond safety deck. 4 adjustable mild steel foot. Threaded eye bolt holes for easy lifting. Top holes for easy leveling. NTEP Legal for Trade 16-016

Part Number	Weight	SKU	List
T3x3-2.5K	240 lb	8142	\$ 1,229.00
T3x3-5K	240 lb	8143	1,229.00
T3x3-10K	245 lb	8144	1,536.00
T3x4-2.5K	280 lb	8145	1,331.00
T3x4-5K	280 lb	8146	1,331.00
T3x4-10K	285 lb	8147	1,690.00
T4x4-2.5K	370 lb	8148	1,311.00
T4x4-5K	370 lb	8149	1,311.00
T4x4-10K	375 lb	8150	1,311.00
T4x5-2.5K	430 lb	8151	1,433.00
T4x5-5K	430 lb	8152	1,443.00
T4x5-10K	435 lb	8153	1,677.00
T5x5-2.5K	540 lb	8154	1,579.00
T5x5-5K	540 lb	8155	1,579.00
T5x5-10K	545 lb	8156	1,872.00

Service Parts

(1) FM J Box & (20)ft FM cable blue Both items shipped in same box	1 lb	7114	272.00
---	------	------	--------



HW-CEP



A&D WEIGHING DIVISION

HW-CEP Intrinsically Safe For Hazardous Environments

Bench Scale for use in hazardous locations that required intrinsically safe equipment. Certified safe for use in FM class 1, Division 1, groups C+D hazardous areas. Stainless steel weighing pan. resists chemicals., scratches and rust. IP65 base is easy to clean. Long battery life with (4) D approval batteries. Indicator for weight, stable, net, zero, PT, hold, MT. keys for: SET, HOLD, COMP, MT, MODE, ON/OFF, Zero, TARE, 0-9, C, ENTER. Overall 9.84" x 17.28" x 15.53" H on hw-10kCEP
12.89" x 23.03" x 30.55" H on HW-60kCEP. 15.35" x 27.2" x 30.55" H on HW-100kCEP and HW-200kCEP.

Part Number	Capacity	Pan	Weight	SKU	List
HW-10KCEP	20 x 0.002 lb	9.8" x 9.8"	18 lb	1464	\$ 2,400.00
HW-60KCEP	150 x 0.002 lb	13" x 16.7"	27 lb	1465	2,700.00
HW-100KCEP	200 x 0.02 lb	15.4" x 20.9"	40 lb	1466	3,120.00
HW-200KCEP	500 x 0.05 lb	15.4" x 20.9"	40 lb	1467	3,360.00

Prices are subject to change without notice. Please call for current prices.

Other items are available from the manufacturers, please call for prices.



PS500 Animal Scale

All stainless steel construction. Rubber slip mat included with each unit. Animals enjoy the slip free surface and are weighed easily. Compact, light weight, accurate and reliable. Weighing modes: lbs, kg. 0.675" 7 segment LCD display. Hold feature, internal rechargeable batteries, auto power shut off. 8 hours continuous use with full charge. A display bracket is included for desk or wall mounting of indicator. 7VDC NI-MH battery, 15VDC 300mA AC adapter included. Indicator 6.5"W x 1.2"D x 3.2"H

Part Number	Capacity	Platform	Weight	SKU	List
PS500-22S	550 x 0.2 lb	22" x 22" x 2"	35 lb	3414	\$ 535.00
PS500-36S	550 x 0.2 lb	22" x 36" x 2"	55 lb	3415	565.00
PS500-42S	550 x 0.2 lb	22" x 42" x 2"	65 lb	3416	650.00

Service Parts

AWT05-501533 adapter 9V	1 lb	3409	31.00
-------------------------	------	------	-------



**PS500-22S
Animal Scale**



TM901 Animal Scale

Veterinary animal scale. Powder coated steel base with stainless steel removable platform cover. 2' large LCD display with blue back light. Rubber mat included for non-slip weighing surface. Compact with handle and transportation wheels. Easy to level with adjustable rubber feet. 300 lb/150 kg capacity. Weighing units: lb, kg, oz. Function keys: Hold, Tare, Zero, ON/Off. Hold function will take measurement even if the animal is moving on the platform. Indicator has ABS enclosure with quick disconnect for load cell and AC adapter. 6' cable from indicator to base. Built in rechargeable battery with 30 hours running time without backlight. Low battery symbol on display will remind you to recharge indicator. Desk or wall mountable. 1 year warranty.

Part Number	Capacity	Platform	Weight	SKU	List
TM901-150	150kg x 50g	38" x 20" x 2"	64.7 lb	4924	\$ 581.00

Service Parts

111700067 indicator bracket TM901	2 lb	4920	26.00
111800245 rubber mat 38"x20" TM901	2 lb	4847	88.60



**TM901
Animal Scale
W/ Rubber Mat**



TM902 Animal Scale

Light weight, easy to use small animal Veterinary scale. 0.75" LCD display with blue back light. Keys for Tare, Zero, Hold, On/Off. Unit is changeable between kg/lb by pressing the "O" button and holding for 2 seconds. Hold feature for animal weighing while the animal is on the weighing pan the indicator will hold the weight even if the animal is moving on the platform. Stainless steel removable platter. Adjustable feet with front bubble level. Coil cord between indicator and base is 10' in length. In-use cover included. Powered by internal rechargeable battery. AC adapter for charging included.

Part Number	Capacity	Platform	Weight	SKU	List
TM902	30 x 0.01 kg	12" x 10"	11 lb	3960	\$ 300.00



**TM902
Animal Scale**

Prices are subject to change without notice. Please call for current prices.

Other items are available from the manufacturers, please call for prices.



A520BT
Body fat

VISIONTECH SHOP

A520BT Vision Tech Body Fat

Body fat scale 396 lb capacity. 12" x 12" with large LED display. Bluetooth connection to your smart phone. Weight units: lb or kg. Measurements are body weight, BMI (Body mass index), Body Fat, water Skeletal Muscle, Bone Mass, Protein, Calorie and Body age. (4) AAA batteries included. Auto turn on with sense technology. Auto off after 30 seconds at Zero or 35 seconds after weighing data is removed. One year Warranty.

Part Number	Capacity	Platform	Weight	SKU	List
A520BT	396 x 0.2 lb 180kg x 0.1kg	12" x 12 x 1"	5 lb	6090	\$ 59.00

VISIONTECH SHOP

520B Vision Tech Bath

Bath scale 396 lb capacity. 12" x 12" with large LED display. Bluetooth connection to your smart phone. Weight units: lb or kg. (4) AAA batteries included. Auto turn on with sense technology. Auto off after 30 seconds at Zero or 35 seconds after weighing data is removed. One year Warranty.

Part Number	Capacity	Platform	Weight	SKU	List
520BW White	396 x 0.2 lb 180kg x 0.1kg	12" x 12 x 1"	4 lb	6266	\$ 48.00
520BP Pink	396 x 0.2 lb 180kg x 0.1kg	12" x 12 x 1"	4 lb	6267	48.00



520BP Bath



762 Seca

seca[®]

Precision for health

762 Seca Bathroom

The precise design classic has a large clear and well defined dial. With a large, low-level non-slip platform and scratch resistant finish it is easy for the patient to step on and weigh. The rugged metal housing withstands years of use under the harshest conditions.

Part Number	Capacity	Platform	Weight	SKU	List
762 Bathroom scale	320 x 1 lb	12" x 18.5 x 4.7"	8 lb	6139	\$ 139.00



TM301 Personal Body Scale

Digital scale with 550 lb maximum capacity. Resolution of 0.1 lbs is best in class. LCD weight display with blue LED backlight. LCD BMI bar graph for Slim; Normal; Fat. Height rod with dual measurements, inches and mm's. Indicator has 7 function keys Tare, Zero, Unit, Print, BMI, Lock (hold function), on/off. Platform size 14" x 14" with bubble level for easy adjustment. Painted white steel construction can be assembled in minutes with included Allen wrenches. ABS indicator with rechargeable battery pack 2000mAh Ni-MH and 12VDC, 500mA adapter is included.

Part Number	Capacity	Weight	SKU	List
TM301 Baby scale	550 x 0.1 lb	34 lb	6325	\$ 595.00

Service Parts

Ni-MH battery pack		2 lb	4844	45.98
AC adapter 100-240VAC to 12VDC		1 lb	6362	28.79



TM301 Personal Body Scale

Health



TM302 Precision Health Scale

Painted steel construction. Foot switch for ON/OFF, UNIT in LBS. ABS indicator has LCD display with blue backlight. Bubble level and adjustable feet makes it easy to level in seconds. Platform is 3.1" high. AC adapter 110VAC to 12VDC and 2000mAh Ni-MH battery included.

Part Number	Capacity	Platform	Weight	SKU	List
TM302	500 x 0.2 lb	14.5" x 14.5"	22 lb	4820	\$ 473.00

Service Parts

TB-M10-SPB-SS foot M10, 2 1/8" dia		1 lb	7673	5.68
Ni-MH battery pack		2 lb	4844	45.98
AC adapter 100-240VAC to 12VDC		1 lb	6362	28.79



TM302 Precision Health Scale

Prices are subject to change without notice. Please call for current prices.

Other items are available from the manufacturers, please call for prices.



TM101
Baby Scale

TM101 Baby Scale

Light weight, digital scale with unique feeding function for weighing before and after baby feeding. Dual capacity 13/33 lbs x 0.005/0.01 lbs. LCD weight display with blue LED backlight. Units of measure lbs/kg. Horizontal measuring rod with dual measurements, inches and mm's. Indicator has 7 function keys Tare, Zero, Unit, Lock (hold function), on/off and two dedicated keys for before and after feeding. Pan size 23.5"L x 9"W. Bubble level for easy adjustment. ABS indicator with rechargeable battery pack; 2000mAh Ni-MH and 12VDC, 500mA. Adapter included.

Part Number	Capacity	Weight	SKU	List
TM101 Baby scale	33 x 0.01 lb	15 lb	6299	\$ 365.00

Service Parts

Ni-MH battery pack		2 lb	4844	45.98
--------------------	--	------	------	-------



MBS-2010
Baby Scale

MBS Baby Scale

Low profile design for maximum weighing security. Auto dampening feature ensures accurate readings even when baby is moving. Water resistant construction. Large easy to read wide angle 1" LCD display. Keys for ON/OFF, KG/LB, HOLD. Auto power saving function. Low battery indication. (1) 9V battery (not included) or 120V adapter (included). Base unit 10.8" x 9.8" x 3.4"H. Overall height 6.9"H.

Part Number	Capacity	Tray	Weight	SKU	List
MBSCU2 baby	44 lb x 0.5 oz 20 kg x 10 g	20.5" x 11.75"	9 lb	6017	\$ 84.00



TM501 Portable Wheelchair scale

Painted steel frame with bolted ABS high strength plastic chair. ABS indicator with LCD display. 7 function keys for ON/OFF, ZERO, TARE, BMI, F, UNITS, LB/KG selectable. Body Mass Index (BMI) function with bar graph, just press BMI and enter patient height and weight, display will show BMI value on LCD screen. Arm rests and handles are standard material made for all wheelchair scales. Foldable foot rest, transport wheels (4), back wheels with brakes. Removable cushion and storage bag included. AC adapter 110VAC to 12VDC and 1800mAh Ni-MH rechargeable battery included.

Part Number	Capacity	Weight	SKU	List
TM501	550 x 0.1 lb	92 lb	4826	\$ 960.00

Service Parts

Ni-MH battery pack	2 lb	4844	45.98
130504300006 indicator M101	4 lb	4842	205.00



TM501
Portable
Wheelchair Scale

Health



TM501
Portable
Wheelchair Scale
w/ Indicator

Prices are subject to change without notice. Please call for current prices.

Other items are available from the manufacturers, please call for prices.



**6550
Portable
Wheelchair Scale**

6550 Portable Wheelchair Scale

Lightweight digital foldup scale for heavyweight tasks. Used for wheelchairs, straight legged chairs and walk up traffic. Two sloped ramps allow loading from either side. Nonslip rubber mats cover deck and ramps. Will fold up for easy rolling to a new location or to storage. Vertical fold up feature takes up less storage space when not in use. Switchable to either pounds or kilograms. Indicator has easy to read LCD with auto power off, automatic zero, motion detect, weight lock-in. Keypad for ZERO, UNITS, HOLD/RELEASE. Power is from (6) "C" batteries (included). Platform size is 38"L x 36"W . Size 45"L x 10"W x 38"H when closed for storage.

Part Number	Capacity	Weight	SKU	List
6550	800 lb x 0.2 lb	94 lb	5978	\$ 3,809.00

Service Parts

0067-B044-0A cable, load cell connection		1 lb	5993	78.25
--	--	------	------	-------



**6855
Portable
Personal Scale**



6855 Portable Personal Scale

High capacity portable digital scale. 600 lb capacity. LCD weight display. Indicator has keys for ON/OFF, LB/KG, HOLD/RELEASE, ZERO. Auto power off to save batteries. Hold/release of display. Automatic zero. Motion detection. Non-slip rubber mat for comfort and safety. Painted white with stainless steel handrail. (6) "C" alkaline batteries (included). Platform size 14"W x 18"D

Part Number	Capacity	Weight	SKU	List
6855 Digital scale	600 lb x 0.2 lb	70 lb	5977	\$ 2,956.00



TM701 Portable Handrail Scale

Accurate, fast and versatile. ABS indicator has front and rear LCD display, also settable to blue backlight. Hand rails on 3 sides. Indicator has 7 function keys for: ON/OFF, ZERO, TARE, HOLD, BMI, F, UNITS, LB/KG selectable. Body Mass Index (BMI) function with bar graph, just press BMI and enter patient weight and display will show BMI value on LCD screen live make it convenient for patient to hold rail while weighing. Painted steel construction can be assembled in minutes. Allen wrenches included. Indicator pole is 48" high. Platform size is 23.5" x 23.5". AC adapter 110VAC to 12VDC and 2000mAh Ni-MH battery included.

Part Number	Capacity	Weight	SKU	List
TM701	550 lb x 0.1 lb	94 lb	4860	\$ 1,138.00

Service Parts

Ni-MH battery pack	2 lb	4844	45.98
122528096 indicator M301	4 lb	4836	229.00



**TM701
Portable
Handrail Scale**



TM503 Ramp Wheelchair Scale

Accurate, fast and versatile. ABS indicator w/ 25mm LCD display and blue backlight. Hand rails on 3 sides. Indicator has 7 function keys for: ON/OFF, ZERO, TARE, HOLD, BMI, F, UNITS, LB/KG selectable. Non slip rubber mat, on and off ramps foldable up to 165 degrees. Handle and wheels for easy transportation around the facility. Live rails make it convenient for patient to hold rail while weighing. Hand rail and indicator pole are foldable for easy storage. Painted steel construction can be assembled in minutes. Allen wrenches included. Indicator pole is 46" high, adjustable indicator angle up to 25 degrees. AC adapter 110VAC to 12VDC and 2000mAh Ni-MH battery included.

Part Number	Capacity	Platform	Weight	SKU	List
TM503	550 x 0.1 lb	33" x 33"	104 lb	4831	\$ 1,306.00

Service Parts

Ni-MH battery pack	2 lb	4844	45.98
130504300006 indicator M101	4 lb	4842	205.00



**TM503
Portable Wheelchair Scale**



**339
Physician Scale**

Physician Scale

Pound and kilogram readings on both front and back of the graduated beam. 350 lb capacity and 160 kg capacity. Model 339 has a height rod 30" to 78" and 76cm to 198cm. Model 338 has both a height rod and wheels for easy transport. Platform size 10.5" x 14.5". Overall size 10.5"W x 14.5"D x 59"H.

Part Number	Capacity	Weight	SKU	List
337 Physician	350 lb x 0.25 lb	34 lb	5974	\$ 395.00
338 Physician w/wheels	350 lb x 0.25 lb	39 lb	5975	500.00
339 Physician w/rod	350 lb x 0.25 lb	37 lb	5976	405.00



400 Physician Scale

Portable physician scale. Rotating poise bars for dual reading of pounds and kilograms. Rugged zinc die cast beam construction with copper, nickel, chrome plating. Beam graduations are engraved in die casting, paint filled with baked enamel finish. Maximum strength unitized steel base. Precision heavy duty unitized steel lever system with heat treated pivots and vee bearings. Vacuum formed ABS high impact plastic platform cover. Model 402KL has measuring rod 24" to 84" and includes 100 lb and 40kg counterweights to increase capacity to 450 lbs and 200kg. Platform size 10.4" x 14" x 3.4"H. Overall size 18-3/8" x 20-1/4" x 57-3/4"H.

Part Number	Capacity	Weight	SKU	List
400KL Physician scale	350 x 0.25 lb	37 lb	907	\$ 340.00
402KL Scale w/measuring rod	160kg x 100g	40 lb	4324	363.00
	450 x 0.25 lb			
	200kg x 100g			

Option for 400KL only

55070 counterweight to increase capacity to 450 lb	1 lb	1826	87.70
500KLROD height rod for 500KL	2.29 lb	1838	64.00

Service Parts for electronic scales

ADPT31 AC adapter 120VAC	0.24 lb	1840	74.28
--------------------------	---------	------	-------



**400KL
Physician Beam Scale**

Prices are subject to change without notice. Please call for current prices.

Other items are available from the manufacturers, please call for prices.



DS2100 Mechanical Physician Scale

Fast and easy to obtain the weight and height of a patient. Slide the poises on the weighbeam to obtain the weight. Scale can be converted from lb to kg by twisting the weighbeam. Powder coated painted steel construction. Overall 10.5"W x 22"L x 58"H. Platform size is 10.5" x 14.5" with a removable slip resistant cover.

Part Number	Capacity	Weight	SKU	List
DS2100	450 lb x 0.25 lb	42 lb	781	\$ 308.00



**DS2100
Mechanical
Physician Scale**



doran

DS5250 Eye Level Physician Scale

Digital display at eye level makes this the fastest and easiest way to weigh a patient. Display is 1.25" high LED. Units are lb, kg and Units lock feature. Controls for Zero, Reweigh, Units, BMI. Height rod adjustment from 2' 0"(61cm) to 6' 6.7"(200cm). Battery operated 5,500 weighments per charge. Internal rechargeable battery uses the USB port to any wall mount charger and be fully charged in six hours. Platform size 14"W x 18"D. Overall size 14"W x 20.5"D x 49.75"H.

Part Number	Capacity	Weight	SKU	List
DS5250 Physician	600 lb x 0.2 lb	22.05 lb	782	\$ 476.00

**DS5250
Physician Scale**



TRANSCELL TECHNOLOGY, INC.

SPS Postal Rate Computing Scale

Postal rate computing scale. Rates include: 1st Class/Priority mail, Express Mail, Canada letter Airmail, Mexico letter airmail, Other International letter Air mail. Keys for ZERO, 1st, Express, Canada, Mexico, International. Liquid crystal display(LCD). Auto shut off after 5 minutes. AC adapter included 120 VAC, 50/60 Hz, 9 VDC, 100ma. 9.2" x 12.4" x 2.9" H NTEP Legal for Trade 97-088 (SPS-30) NTEP Legal for Trade 10-015 (SPS-70DL)

Part Number	Capacity	Platform	Weight	SKU	List
SPS-30	0-4 lb x 0.1 oz 4-30 lb x 0.5 oz	8.9" x 8.3"	12 lb	220	\$ 369.00
SPS-70DL	0-4 lb x 0.1 oz	10" x 9"	15 lb	3311	960.00



SPS-30
Postal Computing Scale



SPS-70DL
Postal Computing Scale



Postal

NCI

NCI scales service parts only

Part Number	Capacity	Weight	SKU	List
Service Parts				
1148-15536 NCI power supply		1 lb	7637	\$ 75.00
PS D/MT 15VDC 120V 60HZ VL/CSA				



NCI power supply

Prices are subject to change without notice. Please call for current prices.

Other items are available from the manufacturers, please call for prices.

Jewelry



TAJ203
Carat Balance

OHAUS®

TAJ Carat Balance

Stainless steel platform. Adjustable feet and level bubble. Backlit LCD display. Jewelry weighing modes that include g, ct, oz, dwt, tical, tola, lb, grain, kg, ozt, 3 tael units - Hong Kong, Singapore, Taiwan. Application modes include weighing, parts counting, automatic sample recalibration. Calibration mass included. Battery and AC operation. RS232 output option. AC adapter included.

Part Number	Capacity	Pan	Weight	SKU	List
TAJ203	200 x 0.005 ct	3.5" dia	4 lb	6173	\$ 601.00



SJX323N/E
Jewelry Balance



OHAUS®

SJX Jewelry Balance

Legal for Trade portable jewelry balances, Class II and Class III certified Carat and Gold balances. For jewelry, precious metals and gemstones. Superior overload protection, large backlit high contrast LCD display, fast stabilization time, multiple weighing units, stainless steel pan, ABS housing, adjustable feet and level bubble. Application modes include weighing, parts counting, display hold, automatic sample recalibration. Integral weigh below hook. AC adapter (included) or 4 AA batteries (not included). USB and RS232 output option.

NTEP Legal for Trade 16-015 II & III

Part Number	Class	Capacity	Pan	Weight	SKU	List
SJX323N/E	II	320 x 0.01 ct	3.7" dia	3.3 lb	8332	\$ 889.00
SJX622N/E	III	620 x 0.1 g	4.7" dia	3.3 lb	8333	1,115.00
SJX1502N/E	II	1,500 x 0.01 g	6.7" x 5.5"	3.3 lb	8334	1,294.00
SJX6201N/E	III	6,200 x 1 g	6.7" x 5.5"	3.3 lb	8335	1,142.00

Options

80252042 CBM-910 Dot matrix printer	2 lb	7426	395.00
80251992 STP-103 Thermal printer (requires 80500525)	2 lb	7419	1,005.00
83032107 RS232 interface w/ cable scout	2 lb	6162	220.00
83032108 USB interface w/ cable	1 lb	6163	220.00
80251930 Adapter for Scout Pro	1 lb	7425	52.00
80251934 Adapter	1 lb	7433	52.00
30268986 Ethernet cable	1 lb	6357	238.00



SJX622N/E
Jewelry Balance



SJX6201N/E
Jewelry Balance



OHAUS®

YA Gold Series

The ultimate in portability. Durable, high quality answer to precision weighing. Perfect for weighing gold and other fine jewelry. Bright blue backlit display. Hinged draftshield cover. SofTouch outer case. Stainless weighing pan.

Part Number	Capacity	Weight	SKU	List
YA102	100 g x 0.01 g	2 lb	6412	\$ 142.00
YA302	300 g x 0.05 g	2 lb	6413	123.00
YA501	500 g x 0.1 g	2 lb	6414	88.00



YA
Gold Series

Prices are subject to change without notice. Please call for current prices.

Other items are available from the manufacturers, please call for prices.



JE Emerald Jewelry Scale

Convenient, compact, portable weighing in the palm of your hand. Throw it in a brief case, keep a few on your showcases, or slip it in your pocket. These little scales with sleek styling, convenient size and new higher capacities are ideal to keep anywhere. Jewelry weighing modes include g, oz, dwt, oz t. 1 Year warranty. 100-120 VAC adapter, 3.25"W x 5.35"D x 0.8"H.

Part Number	Capacity	Pan	Weight	SKU	List
JE120	120g x 0.1g	3"dia	3 lb	6520	\$ 175.00
JE500	500g x 0.1g	5" x 5.75"	3 lb	6522	275.00



JE120 Emerald Jewelry Balance



JS Sapphire Jewelry Scale

Based on the successful Scout II. This model is made for jewelers. Easy to use two button operation and a large, high contrast LCD display. With jewelry weighing modes that include g, ct, oz t, dwt and grains, jewelers have the versatility that is needed for appraisals, bench, showcase and inventory applications. Stainless steel pan. 2 Year warranty. 100-120 VAC adapter, 6.75"W x 8.25"D x 2.4"H.

Part Number	Capacity	Pan	Weight	SKU	List
JS10	50 ct x 0.01 ct 10g x 0.002 g	3"dia	5 lb	6515	\$ 295.00



JS10 Sapphire Jewelry Balance

Jewelry



TPB
Pallet Truck Scale

TPB Pallet Truck Scale

Fast and easy to use. The TPB is great for instant weighing anywhere in your plant. Digital weight indicator programs include accumulation and unit conversion. As soon as your pallet is raised the display will show you the weight. 0.8" white backlit LCD display with 6 function keys: M+, G/N, TARE, ZERO, ON/OFF. Weighing units for: lb/kg. Rechargeable battery provides up to 30 hours of continuous use. AC adapter is also included for charging. Fork dimensions: 47" long, 27" wide, 3.3" high. FOB Fair Lawn NJ

Part Number	Capacity	Weight	SKU	List
TPB-688mm Pallet scale	5,000 x 1 lb	350 lb	2384	\$ 2,026.00

Service Parts

TPB pallet scale indicator		3 lb	2351	279.00
RW indicator for TPR		2 lb	2363	273.60
Main board for RW		1 lb	3764	112.53
GH645 Battery rechargeable lead acid for TPR		4 lb	6114	29.00
Load cell for TPR/TPB		2 lb	2400	162.80
Pump assembly for TPR/TPB		20 lb	4552	552.97



PW800 Pallet Weigh Truck Scale

Service parts only for PW800 pallet weigh scale.

Part Number	Weight	SKU	List
330111 Battery pack (3) D cell rechargeable	2 lb	2671	139.00

Replacement Load Cells: Use any of the following models
65023, TSB, 5123, 3411, DSB, GSB, NSB, BSA, PA6140



PW800
Truck Scale



CPS Pallet Truck Scale

The convenience of a scale in a pallet truck. It is fast and easy to use. Digital weight indicator is a CAS Model CI-2001B with a 6V rechargeable battery. Large easy to read large 1" LCD display. Function keys for ZERO, TARE, GROSS/NET, lb/kg, PRINT, ON, OFF. Fork dimensions: 47.2" long, 27.8" wide, 3.3" high. FOB East Rutherford NJ

Part Number	Capacity	Weight	SKU	List
CPS-1 Pallet truck scale *	3,000 x 1 lb	410 lb	6039	\$ 3,395.00
CPS-2 Pallet truck scale	5,000 x 2 lb	410 lb	6040	3,395.00

*NTEP Legal for Trade 09-003 III 5,000 div

Service Parts

WCP1 cable, battery charger CPS		1 lb	6027	36.00
ZCP2 battery charger w/cable CPS		4 lb	6037	306.00
KCP1 keypad for CPS		1 lb	6050	13.50
RCP1 printer for CPS		2 lb	6051	363.00



CPS-2
Truck Scale



Prices are subject to change without notice. Please call for current prices.

Other items are available from the manufacturers, please call for prices.



LTEF Lift Truck Scale

Carriage size: Standard Class II 16" high x 36" wide. Capacity 5,000 lb with 1 lb divisions. Indicator is model DR2100A, dual line, 32 character LCD display with backlight, 0.5" character size. 12 VDC to 48 VDC power is required. Rugged metal enclosure, dust and water resistant. 8.25"L x 3.19"W x 6.69"H. Numeric keypad, APW entry, ID entry, Accumulation register. Universal mounting bracket. Standard coiled load cell cable 15 ft from indicator to lift. FOB Twinsburg, OH

Part Number	Capacity	Weight	SKU	List
LTEF-16 Class II Lift truck scale	5,000 x 1 lb	400 lb	2744	\$6,819.00

Other models and capacities are available. Please call for a price quote.

Service Part

LC-CABL HR cable, 5 pin conn	2 lb	2748	365.00
------------------------------	------	------	--------



**LTEF-16
Class II
Lift Truck Scale**



**DR2100A
Indicator
Lift Truck Scale**



Fork lift

Lift Truck



Coil lift



Chute lift



Tilt lift

Prices are subject to change without notice. Please call for current prices.

Other items are available from the manufacturers, please call for prices.

Race car



**SW-6K
Race Car System**



**SW-6K Deluxe Race
Car System**



**PT20 CPU
Wireless Indicator**



**RFX
Handheld Wireless Indicator**



SW Race Car Weigh System

Weighing is easily done by jacking up the car. Insert the scale under wheels. Lower car to weigh. Accuracy is 1/10 of 1%.

SW system includes: (4) light duty weigh pads w/ cables, (1) weight indicator, (1) battery recharger, (1) instruction manual. Indicator display is 2 line, 16 characters LCD display. Pushbuttons for ZERO, ON, OFF, PRINT/CONTRAST.

SW Deluxe system includes: (4) heavy duty weigh pads w/cables, (1) weight indicator and printer mounted in a waterproof carrying case, (1) battery recharger, (1) instruction manual. Indicator display is 4 line, 20 characters LCD display. Pushbuttons for ZERO, LB/KG, TEST, LIGHT, PRINT, HELP, SET TIME/DATE, ON, OFF.

RFX PT20 CPU system includes: CPU, waterproof case, printer, power supply. 15 digit, backlight LCD display. USB/RS232 output. Pushbuttons for SET LATITUDE/ALTITUDE CORRECTIONS, VEHICLE/USER INFORMATION, TIME/DATE STAMP, CONTINUOUS PRINTING, CALIBRATE, ON/OFF, ZERO, ON-DEMAND PRINTING, TARE, PEAK, LB/KG, SET ALARM/TARE/ARM.

RFX Indicator: Compatible with LP600, PT300, AX900, CS3000, SW and CW250 scale systems. 4 digit LCD backlight display. Capacity to interface up to 12 scales. 300 ft line of site. Up to 40 hours continuous use before recharge. Standard (AA) batteries. Read only mode. USB/RS232 output. Set latitude/altitude corrections. Pushbuttons for CONTINUOUS PRINTING, CALIBRATE, ON/OFF, ZERO, ON-DEMAND PRINTING, TARE, PEAK, LB/KG. Screens for: Individual Weight, Gross/NET/Tare, Axle Group, Accumulative Total, Center of Balance, Tare. Includes Indicator, rechargeable batteries, battery charger, case.

All indicators are powered by (6) internal "AA" NiCad batteries, except for PT20 CPU which uses "D" cell batteries, which are included.

All indicators will show a minimum of your choice of total weight, left or right side, front or back, or any wheel, also percent by wheel.

Deluxe weighing pads are 35 lb. SW Deluxe indicator case is 17"W x 11"D x 7"H, 10 lb.

Part Number	Capacity	Weight	SKU	List
SW-6K Race car system	6,000 x 1 lb	145 lb	4845	\$ 3,795.00
SW-8.8K Race car system	8,800 x 1 lb	145 lb	4846	4,995.00
SW-8.8K Deluxe car system	8,800 x 1 lb	155 lb	4848	7,495.00
SW-20K Deluxe car system	20,000 x 1 lb	165 lb	1958	10,995.00

Options

100056 System carrying case	39 lb	1962	895.00
100330 Ramp (4) 15" x 15" Snap in or SW Deluxe	66 lb	4849	795.00
100417-4 Ramp (4) 15" x 36" x 4"	66 lb	4850	1,095.00

PT20 CPU Wireless indicator, battery operated
Includes tape printer. Prints axle, axle group, total weight T&D, etc.

RFX Handheld wireless indicator 4 lb 6177 995.00

Service Parts

603070 load cell 700 kg 4 lb 6392 340.00



Prices are subject to change without notice. Please call for current prices.

Other items are available from the manufacturers, please call for prices.



RW-S/L Road Weigher Platform & Indicator

Wheel weigher scale made of rugged cast aluminum. Display is built in 1" LCD w/back light. Used for car, truck and custom applications. Can be used for any mobile weight inspection. Scales are linkable for multi-axle weighing. Up to 6 scales can be linked together. 1% accuracy. Single and double width platforms are available. Each scale will display the individual weight and total weight by pressing the LOCAL/TOTAL button. Battery operated using (12) AA rechargeable or dry cell batteries. Each scale has (2) battery sticks with (6) AA cells in each. 20 hours continuous use before recharging. Rechargeable batteries are included. Also includes a 120 VAC to 12 VDC charger. NTEP Legal for Trade 03-047

Part Number	Capacity	Weight	SKU	List
12.2"W x 13.4" Platform overall size 21.1"L x 18"W x 2.4"H				
RW-5S	10,000 x 5 lb	66 lb	4714	\$ 1,855.00
RW-05S NTEP	10,000 x 50 lb	66 lb	5383	1,855.00
RW-10S	20,000 x 10 lb	66 lb	4715	1,855.00
RW-10S NTEP	20,000 x 50 lb	66 lb	5384	1,855.00

24.6"W x 13.4" Platform overall size 22.3"L x 28.3"W x 2.4"H				
RW-5L	10,000 x 5 lb	102 lb	4716	2,375.00
RW-05L NTEP	10,000 x 50 lb	102 lb	5385	2,375.00
RW-10L	20,000 x 10 lb	102 lb	4717	2,375.00
RW-10L NTEP	20,000 x 50 lb	102 lb	5386	2,375.00

Options

2 scale totalizer cable RW-S/L series	7 lb	4718	95.00
4 scale totalizer cable RW-S/L series	14 lb	4719	285.00
6 scale totalizer cable RW-S/L series	21 lb	4720	475.00

Service Parts

Charger adapter 120VAC to 12VDC	3 lb	4782	55.00
WRW6 cable 18" w/female connector to RW	0.19 lb	4783	35.00
YRW2 (2) batter sticks (6)AA each	3 lb	5331	89.00



RW-S
Platform/Indicator



RW-L
Platform/Indicator



**RW-2601P
Indicator**

RW-2601P Road Weigher Indicator only

This indicator will connect up to 6 scales simultaneously. Completely self contained portable unit. Will print weight and time & date with built in high speed dot matrix receipt printer. RS232 serial port to connect to a PC or remote display. 10 vehicle number memories. Large easy to read LCD display with back light. Display individual weight of each scale with printed total weight. Totalizer cable included with each scale. Rechargeable battery pack is built in. Charger/adaptor 120VAC is included.

Part Number	Capacity	Weight	SKU	List
RW-2601P multi platform indicator		27 lb	4723	\$ 2,295.00

Service Parts

Charger adapter 120VAC to 12VDC		3 lb	4784	73.40
---------------------------------	--	------	------	-------



LP600 Wheel Load Scale

Low profile, light weight all aluminum, digital, self contained, high capacity wheel load scale. 1% accuracy. Display units are either kg or lb depending on model. Battery charging cable, connectors and transformer 120 VAC to 12 VDC is included with orders for 2, 4 or 6 scales. Includes (4) Nicad batteries per scale. 300 hours continuous use before recharge. Low power 1" LCD display is easy to read in daylight. RS232, RS485 output to printers or remote displays. Separate switches for ON and OFF. ZERO switch will set zero. Platform 22.4" x 15". Overall 30" x 16" x 1.5"H. 44 lb. NTEP Legal for Trade Class IV for LP600-20Kx50

RFX Indicator: Compatible with LP600, PT300, AX900, CS3000, SW and CW250 scale systems. 4 digit LCD backlight display. Capacity to interface up to 12 scales. 300 ft line of site. Up to 40 hours continuous use before recharge. Standard (AA) batteries. Read only mode. USB/RS232 output. Set latitude/altitude corrections. Pushbuttons for CONTINUOUS PRINTING, CALIBRATE, ON/OFF, ZERO, ON-DEMAND PRINTING, TARE, PEAK, LB/KG. Screens for: Individual Weight, Gross/NET/Tare, Axle Group, Accumulative Total, Center of Balance, Tare. Includes Indicator, rechargeable batteries, battery charger, case. NTEP Legal for Trade 00-091

Part Number	Capacity	Weight	SKU	List
Pounds				
LP600-30Kx50	30,000 x 50 lb	49 lb	6483	\$ 4,495.00
LP600-20Kx20	20,000 x 20 lb	45 lb	4822	3,495.00
LP600-20Kx10	20,000 x 10 lb	45 lb	4823	3,645.00
LP600-10Kx5	10,000 x 5 lb	45 lb	4824	3,645.00
LP600-5Kx5	5,000 x 5 lb	45 lb	4825	3,495.00
Options				
101025 2 Scale carrying case for LP600		40 lb	4827	1,595.00
101039 4 Scale carrying case for LP600		60 lb	4828	1,795.00
101044 6 Scale carrying case for LP600		90 lb	4829	2,595.00
170118 Dummy pad for LP600		45 lb	4830	599.00
101221 PT20 CPU Wireless indicator, battery operated Includes tape printer. Prints axle, axle group, total weight T&D, etc.		20 lb	3698	2,995.00
RFX Handheld wireless indicator		4 lb	6177	995.00
Service Parts				
330010 Battery pack (6) AA NiCad stick, old style		1 lb	1960	44.00
100480 120V charging cable (1) scale w/ transformer		1 lb	1508	160.00



LP600
Wheel Load Scale



RFX Indicator



PT20 CPU
Wireless Indicator

Wheelload

Prices are subject to change without notice. Please call for current prices.

Other items are available from the manufacturers, please call for prices.

13-01 Pollitt Dr Ext
Fair Lawn NJ 07410
201-797-2718

Totalcomp
Scales & Balances

www.totalcomp.com
sales@totalcomp.com
Fax 201-797-2287

Wheel Load



**PT300DW
Wheel Load Scale**



**100050
2 Scale carrying case**

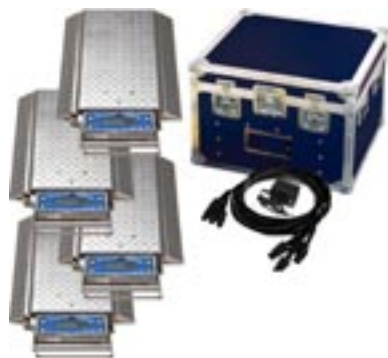

**100051
4 Scale carrying case**

PT300DW Wheel Load Scale

Heavy duty, wireless, all aluminum electronic self contained wheel load scale. 1% accuracy. Includes (4) rechargeable Nicad batteries per scale. Has solar charging panels that virtually eliminate the need to manually recharge batteries between uses. LOCAL/TOTAL switch will show the individual scale weight or the total of all scales in the system. ZERO switch set the system to read zero. PRINT/ACCUMULATE button will print and also accumulate weight to total function. ON/OFF switch will control power. 22" x 26" x 3"H, 60 lb.

Part Number	Capacity	Weight	SKU	List
14" x 22" platform				
PT300DW-55	5,000 x 5 lb	60 lb	2921	\$ 2,295.00
PT300DW-5	10,000 x 5 lb	60 lb	1660	2,445.00
PT300DW-10	20,000 x 10 lb	60 lb	1659	2,445.00
PT300DW-20	20,000 x 20 lb	60 lb	1658	2,295.00
PT300DW-30	30,000 x 50 lb	60 lb	2922	3,295.00
PT300DW-40	40,000 x 100 lb	60 lb	2923	3,795.00

Options

100050 2 Scale carrying case for PT300DW	40 lb	1677	1,195.00
100051 4 Scale carrying case for PT300DW	60 lb	1678	1,695.00
100052 6 Scale carrying case for PT300DW	90 lb	1679	2,595.00
100480 Charger & cable (1) scale	2 lb	1508	160.00
100492 Charger & cable (2) scales	2 lb	1509	254.00
100493 Charger & cable (4) scales	2 lb	1510	424.00
100494 Charger & cable (6) scales	2 lb	1004	594.00

Service Parts

250327 Keypad for PT300 (8) button	1 lb	6185	133.49
240063 LCD display	1 lb	6188	49.95
250409 Keypad PT300 (4) button	1 lb	6199	153.49
810027 Main board PT300 (4) button	1 lb	6200	595.00
330010 battery pack w/(6) AA NiCad batteries	1 lb	1960	44.00
330158 battery pack w/(4) AA NiCad batteries	1 lb	2316	39.00
100490 Totalizer cable for 6 scales(15',25',15',25',15'), old style	1 lb	1519	510.00

1.3 mv/v, 1000/1000 ohms, 3 ft 4 cond cable, anodized aluminum, IP67.

Part Number	Capacity	Weight	SKU	List
000196-T Load cell, blue cable	10,000 lb	12 lb	5559	\$ 432.36
New style 1.3 mv/v				

**000196-T
for PT300**

Prices are subject to change without notice. Please call for current prices.

Other items are available from the manufacturers, please call for prices.



PT300 Wheel Load Scale

Heavy duty, wireless, all aluminum electronic self contained wheel load scale. 1% accuracy. Includes (4) rechargeable Nicad batteries per scale. Has solar charging panels that virtually eliminate the need to manually recharge batteries between uses.

LOCAL/TOTAL switch will show the individual scale weight or the total of all scales in the system. ZERO switch set the system to read zero. PRINT/ACCUMULATE button will print and also accumulate weight to total function. ON/OFF switch will control power. 16" x 20" x 3"H, 42 lb.

NTEP Legal for Trade 90-106 for PT300-50

Part Number	Capacity	Weight	SKU	List
12" x 12" platform				
PT300-20	20,000 x 20 lb	42 lb	1413	\$ 1,695.00
PT300-10	20,000 x 10 lb	42 lb	1414	1,935.00
PT300-10 (Wired)	20,000 x 10 lb	42 lb	2151	1,495.00
PT300-50	20,000 x 50 lb	42 lb	1412	1,695.00
PT300-5	10,000 x 5 lb	42 lb	1415	1,845.00
PT300-55	5,000 x 5 lb	42 lb	4044	1,645.00

Options

100047 2 Scale carrying case for PT300	30 lb	1417	1,095.00
100048 4 Scale carrying case for PT300	40 lb	1418	1,395.00
100049 6 Scale carrying case for PT300	60 lb	1419	1,495.00
100088 PT300-DP Dummy pad 12" x 20" x 3"H	30 lb	1296	445.00
RFX Handheld wireless Indicator	4 lb	6177	995.00

100480 Charger & cable (1) scale	2 lb	1508	160.00
100492 Charger & cable (2) scales	2 lb	1509	254.00
100493 Charger & cable (4) scales	2 lb	1510	424.00
100494 Charger & cable (6) scales	2 lb	1004	594.00

PT20 CPU wireless indicator, battery operated, portable. Includes built in tape printer. Prints axle weight, axle group, total weight, time & date. Includes cables w/connectors.	20 lb	3698	2,995.00
---	-------	------	----------

Service Parts

250327 Keypad for PT300	1 lb	6185	133.49
240063 LCD display	1 lb	6188	49.95
250409 Keypad PT300 (4) button	1 lb	6199	153.49
810027 Main board PT300 (4) button	1 lb	6200	595.00
330010 battery pack w/(6) AA NiCad batteries	1 lb	1960	44.00
330158 battery pack w/ (4)AA NiCad batteries	1 lb	2316	39.00
100490 Totalizer cable for 6 scales(15',25',15',25',15'), old style	1 lb	1519	510.00

1.3 mv/v, 1000/1000 ohms, 3 ft 4 cond cable, anodized aluminum, IP67.

Part Number	Capacity	Weight	SKU	List
000196-T Load cell, blue cable 10,000 lb		12 lb	5559	\$ 432.36
New style 1.3 mv/v				



PT300
Wheel Load Scale



PT300
Wireless Wheel Load
Scale System



100088
PT300-DP
Dummy Pad



000196-T
for PT300

Wheelload

Prices are subject to change without notice. Please call for current prices.

Other items are available from the manufacturers, please call for prices.

13-01 Pollitt Dr Ext
Fair Lawn NJ 07410
201-797-2718

Totalcomp
Scales & Balances

www.totalcomp.com
sales@totalcomp.com
Fax 201-797-2287

Hanging



235-6S
Hanging Scale

235 Hanging Scale

Shatterproof ABS case. Lightweight and corrosion resistant. Maintenance free. High strength stainless steel fittings.

Part Number	Capacity	Weight	SKU	List
235-6S 22 lb	22 lb x 0.2 lb	10 lb	4397	\$ 110.00



820 Hanging Dial Scale

The 820 and 1030 dial scales are made to strict standards and designed to pass individual state's Weights and Measure inspections. They are sold as approximating scales only.

The 820 scale is modern both in construction and appearance. Designed to withstand hard usage and will continue to perform with accuracy. This scale has an 8" dial and has 3 different scoops. Bronze bearings and springs are made of alloys for precision weighing. Heat treated precision ground pinions assure repeatable and accurate weight readings. Single face or double face for customer to see weight reading. Open face or glass cover to protect pointer.

The 1030 scale has a 10" dial. All steel construction makes this scale rugged and accurate. Choice of deep pan and single or double face. Ball bearings make for smooth operation and guarantee long wear and trouble free service.

Part Number	Capacity	Weight	SKU	List
820V w/ vegetable scoop, w/o glass	20 lb x 1/2 oz	10 lb	5322	\$ 191.67
820VG-PX w/ vegetable scoop, glass	20 lb x 1/2 oz	10 lb	5323	225.00
820VGD-PX w/ vegetable scoop, glass double face	20 lb x 1/2 oz	10 lb	5324	280.00

820PG w/ pan, glass	20 lb x 1/2 oz	10 lb	5326	264.38
1030P w/ deep pan	30 lb x 1 oz	15 lb	5330	538.00

Service Parts

820HG-PX Head only	20 lb x 1/2 oz	10 lb	5336	191.67
820V Vegetable scoop only	20 lb	4 lb	5339	41.67

Scoop	Construction	Dimensions
820V	Galvanized steel	16" x 11.5" x 5"
820P	Aluminum	12" x 3"
1030V	Galvanized steel	20" x 14" x 7"
1030P	Aluminum	12" x 3"



820
Hanging dial scale



820V
Vegetable scoop



820P
Hanging pan

Prices are subject to change without notice. Please call for current prices.

Other items are available from the manufacturers, please call for prices.



IN-50 Chatillon Hanging Scale

Heavy gauge solid brass construction. Precision steel springs for outstanding reliability, including salt water applications. Ideal for weighing fish, testing your line or setting your drag. Avoirdupois and metric graduations that are deeply embossed for easy reading. Zero/tare knob is standard. Fixed holding loop and large open hook included. 5 year exclusive warranty.

Part Number	Capacity	Weight	SKU	List
IN-50 w/ MRP	50 lb x 8oz	2 lb	2032	\$ 182.00



IN-50 Hanging Scale



8260DD-T-H Chatillon Hanging Scale

Mechanical hanging scale is chrome plated steel with excellent performance even in hot temperatures. With 13 inch glass covered double dial head. H44 Class III legal for trade. Capacity is reached in 3 pointer revolutions. Adjustable tare up to 10%. NTEP Legal for Trade 88-060

Part Number	Capacity	Weight	SKU	List
8260DD-T-H	60 lb x 1 oz	16 lb	2015	\$ 933.00



8260DD-T-H Hanging Scale



DCS-CD Hanging Scale

Aluminum die cast case hanging scale. Easy to read large LCD display with backlight. Battery operated (3) AA batteries, included. Battery life is 30 hours. Hook and shackle included. Remote control included (2)AA batteries, included. Soft touch tactile keyboard. Weighing units LB/KG.

Part Number	Capacity	Weight	SKU	List
DCS-CD500	500 x 0.2 lb	4 lb	2054	\$ 249.00
DCS-CD1000	1,000 x 0.5 lb	4 lb	2055	249.00
DCS-CD2000	2,000 x 1 lb	4 lb	2056	249.00



DCS-CD Hanging Scale

Hanging

Prices are subject to change without notice. Please call for current prices.

Other items are available from the manufacturers, please call for prices.

13-01 Pollitt Dr Ext
Fair Lawn NJ 07410
201-797-2718



www.totalcomp.com
sales@totalcomp.com
Fax 201-797-2287



**THS
Digital Hanging Scale**

THS Digital Hanging Scale

Safety overload up to 150%. 16.5mm digits high LCD display. Hanging loop and S-hook. Selectable weighing unit (kg/lb). Function keys for ZERO, TARE, CHANGE WEIGHING UNIT, HOLD. (3) AA batteries included. 12"L x 3"W x 2"D

Part Number	Capacity	Weight	SKU	List
THS-44	44 x 0.02 lb	1 lb	3481	\$ 169.00
THS-88	88 x 0.05 lb	1 lb	3482	169.00
THS-220	220 x 0.1 lb	1 lb	3483	169.00
THS-440	440 x 0.2 lb	1 lb	3484	169.00



**Electro Samson
Hand held
hanging scale**

Electro Samson Hand Held Hanging Scale

Hand held scale. Angled LCD display for easy reading. Displayed units are kg, lb-oz and decimal lb. Function keys for ON/ZERO, OFF, HOLD, UNIT. Auto shut off after 2 minutes inactivity. Hold feature will hold the highest weight until reset. Dimensions 340mm x 95mm x 55mm. 9 volt alkaline battery not included.

Part Number	Capacity	Weight	SKU	List
Electro Samson 22 lb	22 lb x 0.02 lb	3 lb	4378	\$ 115.00
Electro Samson 55 lb	55 lb x 0.05 lb	3 lb	4379	140.00
Electro Samson 99 lb	99 lb x 0.1 lb	3 lb	4363	160.00



CS200 Hanging Scale

High accuracy, compact digital hanging scale uses a 12 bit A/D converter for accuracy +/- 0.1% of applied load. Weatherproof ABS plastic case assures maximum protection against moisture, dust and rough usage. High visibility 1/2" high LCD digital readout provides easy reading of weights. Membrane push button switches allow simple trouble free operation. Power is supplied by (1) 9 volt alkaline battery (not included). Peak hold, stainless steel hooks. Function keys for ZERO, lb/kg, ON/OFF. Overall case size 3.75"W x 2"D x 6"H.

Part Number	Capacity	Weight	SKU	List
CS200-50	50 x 0.02 lb	2 lb	3868	\$ 595.00
CS200-100	100 x 0.05 lb	2 lb	3869	595.00
CS200-250	250 x 0.1 lb	3 lb	3870	595.00
CS200-500	500 x 0.2 lb	3 lb	3032	595.00



CS200 Hanging Scale



MSI Hanging Scale

Service part only.s.

Part Number	Capacity	Weight	SKU	List
Service Parts				
500703-0013 MSI load cell	120 lb	5 lb	460	\$ 1,687.00

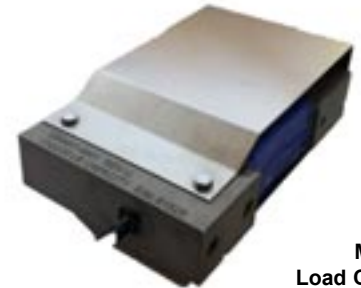

MSI Load Cell



SHS Crane Scale

The SHS crane scale offers a strong, safe solution for weighing heavy, suspended loads such as commercial fishing nets, crates and machinery in industrial shipping and production operations. Bright LED display for easy viewing in most environments. Ruggedly constructed, the SHS has a weight capacity up to 300kg. A remote control allows safe and simple operation of the scale from a distance, including outdoors. The hold function retains the value on the display after the item is removed from the scale, allowing time for the operator to record the weight. Programmable auto power-off to save energy. Rechargeable battery included for operation almost anywhere.

Part Number	Capacity	Weight	SKU	List
SHS100a	100 x 0.02 lb	4 lb	1683	\$ 565.00
SHS300a	300 x 0.05 lb	4 lb	1684	585.00
SHS600a	600 x 0.1 lb	4 lb	1685	595.00



SHS Crane Scale

Crane

Prices are subject to change without notice. Please call for current prices.

Other items are available from the manufacturers, please call for prices.

13-01 Pollitt Dr Ext
Fair Lawn NJ 07410
201-797-2718



www.totalcomp.com
sales@totalcomp.com
Fax 201-797-2287



**CS750
Crane Scale**



**Infrared
Remote
Control**



CS750 Crane Scale

High accuracy, compact digital hanging scale uses a 20 bit A/D converter for accuracy +/- 0.1% of applied load. Keyboard setup and digital calibration. Includes wireless infrared remote control for ON, Off, Zero, Tare. High visibility 1" high LCD digital readout provides easy reading of weights. Programmable display updates from 1 to 127/sec. Programmable digital filter averaging sample size 1 to 31. Membrane push button switches allow simple trouble free operation. Power is supplied by (6) "D" cell batteries(not included). Efficient micro controller gives up to 1 year of battery life. Auto shut off after 5 minutes without use. Tare up to 100%. Zero up to 100%. Indicator lights for lb/kg. Function keys for ON/OFF, ZERO, BACK LIGHT. Overall case size 8.5"W x 5"D x 4.25"H.

NTEP Legal for Trade 97-135

Part Number	Capacity	Weight	SKU	List
CS750-100	100 x 0.05 lb	8 lb	2644	\$ 1,145.00
CS750-300 *	300 x 0.1 lb	8 lb	2645	1,145.00
CS750-500 *	500 x 0.2 lb	8 lb	2646	1,195.00
CS750-1000 *	1,000 x 0.5 lb	8 lb	2647	1,195.00

* NTEP

Options

184256 RS232 Serial output	1 lb	2648	195.00
----------------------------	------	------	--------

Service Parts

360105 Remote Control	1 lb	3714	62.00
250348 keypad 4 button (old)	1 lb	2673	133.49
2505521 keypad 6 button (new)	1 lb	2675	133.49

CS1500 Crane Scale

High accuracy, using a 20 bit A/D converter gives +/-0.1% of applied load. Keyboard setup and digital calibration. Includes wireless infrared remote control for ON, Off, Zero, Tare. All electronics are shock mounted in a weatherproof cast aluminum case which assures maximum protection against moisture, dust and rough usage. High visibility 0.8" high LED digital readout provides easy reading of weights. Programmable display updates from 1 to 127/sec. Programmable digital filter averaging sample size 1 to 31. Recessed push button switches allow simple trouble free operation. Power is supplied by (8) "D" cell batteries(not included). Efficient micro controller gives up to 100 hours of battery life. Auto shut off after 5 minutes without use. Indicator lights for lb/kg. Tare up to 100%. Zero up to 100%. Function keys for TARE, PRINT, lb/kg, ZERO, MODE, SET, ON, OFF. Overall size 9"Wx15"Dx17"H.

NTEP Legal for Trade 97-135

Part Number	Capacity	Weight	SKU	List
CS1500-500	500 x 0.2 lb	25 lb	2652	\$ 1,695.00
CS1500-2000	2,000 x 1 lb	25 lb	2654	2,095.00
CS1500-5000	5,000 x 2 lb	47 lb	2655	2,695.00
CS1500-10000	10,000 x 5 lb	47 lb	2656	2,695.00

Options

184507 RS232 Serial output	1 lb	7061	49.00
----------------------------	------	------	-------

Service Parts

360105 Remote Control	1 lb	3714	39.00
250361 Keysheet	0.1 lb	3788	133.49
000062 load cell 2,000 lb for CS	2.22 lb	3750	807.72



**CS1500
Crane Scale**

**Infrared
Remote
Control**





NC1 Crane Scale

Portable crane scale. Easy to install and operate. LCD display 1" high with electric luminescent back light. Ni-Cad battery (rechargeable) and AC adapter for recharging. Operating time is 48 hours. Charging time is 1.5 hours. Solid aluminum die casting case. Low battery indicator. Tare up to 100%. Zero up to 2%. Function keys for ON, OFF, ZERO, TARE, kg/lb. Full tare subtraction. Includes Wireless Remote Control. Sealed to IP67. Case dimensions 10.2"W x 5.3"D x 18.9" H. NTEP Legal for Trade 96-164

Part Number	Capacity	Weight	SKU	List
NC1-250	250 lb x 0.1 lb	19 lb	2636	\$ 745.00
NC1-500	500 lb x 0.2 lb	19 lb	2637	745.00
NC1-1000	1,000 lb x 0.5 lb	20 lb	2638	745.00

Service Parts

ZNC4 battery, 1A4A519B	3 lb	7022	66.00
7599-NCO-0000 AC adapter	1 lb	5962	65.70
RNC1 remote control for NC1	1 lb	2635	71.42



NC1
Crane Scale
w/Remote Control



CCB Crane Scale

Wireless crane scale. 2,000 lb to 20,000 lb capacities. LCD display 1-3/16" high with back light. Swivel Crosby hook. Includes (1) Lithium Polymer (LiPo) battery pack and AC adapter for recharging. Includes infrared remote control. ZigBee wireless capabilities. Sealed to IP67. Case dimensions 8.6"W x 10"D x 16" to 20.7"H.

Part Number	Capacity	Weight	SKU	List
CCB-1TLF	2,000 lb x 0.5 lb	25 lb	4979	\$ 1,395.00
CCB-3TLF	5,000 lb x 1 lb	40 lb	4980	1,495.00
CCB-5TLF	10,000 lb x 2 lb	45 lb	4981	1,695.00
CCB-10TLF	20,000 lb x 5 lb	70 lb	4982	2,795.00

Options

CRD-2300F wireless remote display 5 digits 2.3" H	5 lb	4983	495.00
CRD-3000F wireless remote display 5 digits 3" H	7 lb	4984	595.00

Service Parts

CRC-100 handheld indicator, portable, ZigBee	3 lb	4985	395.00
ZCC1 battery pack, lithium polymer 3.7VDC 4,000 ma	1 lb	4986	120.00



CCB
Crane Scale
w/Remote Control

Prices are subject to change without notice. Please call for current prices.

Other items are available from the manufacturers, please call for prices.

13-01 Pollitt Dr Ext
Fair Lawn NJ 07410
201-797-2718

Totalcomp
Scales & Balances

www.totalcomp.com
sales@totalcomp.com
Fax 201-797-2287



**Caston-2
Crane Scale**



Remote Control

Caston 2 Crane Scale

Crane scale with wireless remote control. Large bright red LED display 1.2" high. Auto span calibration. (2) Ni-Cad rechargeable battery packs and recharger are included. One pack is in the scale and the other is a spare that should be kept fully charged. Typical 72 hours between recharge. Low battery indication. Tare up to 100%. Zero up to 2%. Function keys on both scale housing and remote control for ON, OFF, ZERO, TARE. Full tare subtraction. Dimensions 9.1" W x 14.2" D.

Part Number	Capacity	Height	Weight	SKU	List
CAST2-PLUS(1K)	1,000 lb x 0.5 lb	13.8"	49 lb	2639	\$ 1,325.00
CAST2-PLUS(2K)	2,000 lb x 1 lb	13.8"	50 lb	2640	1,325.00
CAST2-PLUS(5K)	5,000 lb x 2 lb	16.9"	62 lb	2641	1,325.00
CAST2-PLUS(10K)	10,000 lb x 2 lb	16.9"	72 lb	2470	1,495.00

Service Parts

ZC29 battery pack assy			4.54 lb	248	132.00
ZC24 6794-A00-0050 battery, 6 volt,			4 lb	515	73.40
ZC27 battery case assy			2 lb	259	55.00
ZC2A battery charger (Old ZC26)			3 lb	5267	280.50
WC26 battery box cable			1 lb	371	20.00
WC27 battery charger cable			1 lb	399	30.00
HC28 safety latch 2t-5t			1 lb	327	37.85
RC11 Remote control for Caston II			1 lb	539	71.42



Caston 3 Crane Scale Bluetooth Capable

Crane scale with wireless remote control. Large bright red LED display, 6 digit 1.5" high. Auto span calibration . (2) Ni-Cad rechargeable battery packs and recharger are included. One pack is in the scale and the other is a spare that should be kept fully charged. 14-24 hours between recharge. Low battery indication. Hold function automatic, manual. Function keys on both scale housing and remote control for ON, OFF, ZERO, TARE, HOLD, BATT. Sealed to NEMA 4 IP65. Dimensions 11" W x 13.1" D.

Part Number	Capacity	Height	Weight	SKU	List
CAST3-PLUS(10K)	10,000 lb x 2 lb	22.0"	100 lb	2685	\$ 2,075.00
CAST3-PLUS(20K)	20,000 lb x 5 lb	33.3"	155 lb	2686	3,295.00
CAST3-PLUS(30K)	30,000 lb x 10 lb	35.0"	161 lb	1912	3,795.00
CAST3-PLUS(40K)	40,000 lb x 10 lb	39.0"	240 lb	1913	4,295.00
CAST3-PLUS(60K)	60,000 lb x 20 lb	53.2"	710 lb	1819	11,795.00
CAST3-PLUS(100K)	100,000 lb x 20 lb	73.2"	1,050 lb	1723	20,295.00

Options

TWN-B Bluetooth portable handheld indicator	2 lb	1846	595.00
THD-BT Bluetooth module fill retrofit kit	2 lb	1847	250.00

Service Parts

6794-A00-0020 rechargeable battery, 6 volt, VT610	10 lb	516	85.70
ZC 3C rechargeable battery, 12 volt, VT 1207	10 lb	722	85.70
HC28 safety latch 2t-5t	1 lb	327	37.85
WC32 battery cable 12V-4 pins	1 lb	707	33.00
ZC3B battery charger 4 pin	1.36 lb	706	306.00
RC33 Remote control for Caston III	1 lb	540	71.42



**Caston III
Crane Scale w/Remote Control**



**CS Series
Electronic Crane Scale w/
Remote**



CS Series Salter Electronic Crane Scale

Aluminum die-cast case, alloy steel load cell, hook and shackle. 5 digit, 1/2" Bright LED display has adjustable brightness for any environment. Function keys for ON/OFF, TARE, ZERO. Units of measure displays kg or lb. Calculates total weight. Rechargeable battery with AC power adapter. Operates 20 hours between charges. Includes wireless remote control, requires (2) "AA" batteries, puts all scale functions at your fingertips. Distance controls for zero, tare, peak, accumulator and power. Overall size 12"L x 11"W x 7.5"H.

Part Number	Capacity	KG	Weight	SKU	List
CS1000	1,000 x 0.5 lb	500 x 0.2 kg	11 lb	6060	\$ 580.00
CS2000	2,000 x 1 lb	1,000 x 0.5 kg	11 lb	6061	640.00

Service Parts

AWT25-500448 battery .6V 5AH CS series			2.1 lb	6018	138.00
--	--	--	--------	------	--------



MSI Crane Scale

Service parts only for MSI Crane Scale

Part Number	Weight	SKU	List
500703-0013 MSI load cell 120 lb	5 lb	460	\$ 1,687.00



IHS Crane Scale

The SHS crane scale offers a strong, safe solution for weighing heavy, suspended loads such as commercial fishing nets, crates and machinery in industrial shipping and production operations. Bright LED display for easy viewing in most environments. Ruggedly constructed, the SHS has a weight capacity up to 300kg. A remote control allows safe and simple operation of the scale from a distance, including outdoors. The hold function retains the value on the display after the item is removed from the scale, allowing time for the operator to record the weight. Programmable auto power-off to save energy. Rechargeable battery included for operation almost anywhere.

Part Number	Capacity	Height	Weight	SKU	List
IHS2a	2,000 lb x 0.5 lb	19"	43 lb	1689	\$ 1,755.00
IHS6a	6,000 lb x 1 lb	19"	43 lb	1690	1,885.00
IHS10a	10,000 lb x 2 lb	19"	43 lb	1691	2,160.00
IHS20a	20,000 lb x 5 lb	21"	72 lb	1692	3,120.00



IHS
Crane Scale



LHS Crane Scale

The SHS crane scale offers a strong, safe solution for weighing heavy, suspended loads such as commercial fishing nets, crates and machinery in industrial shipping and production operations. Bright LED display for easy viewing in most environments. Ruggedly constructed, the SHS has a weight capacity up to 300kg. A remote control allows safe and simple operation of the scale from a distance, including outdoors. The hold function retains the value on the display after the item is removed from the scale, allowing time for the operator to record the weight. Programmable auto power-off to save energy. Rechargeable battery included for operation almost anywhere.

Part Number	Capacity	Weight	SKU	List
LHS1000a	1,000 x 0.02 lb	12 lb	1686	\$ 960.00
LHS3000a	3,000 x 0.05 lb	12 lb	1687	1,100.00
LHS4000a	4,000 x 1 lb	12 lb	1688	1,360.00



LHS
Crane Scale

Dynamometer

DILLON



AP Mechanical Dynamometer

AP Mechanical Dynamometer

Portable 5" or highly visible 10" dials. Constructed of high strength composite (5") or rugged cast aluminum (10") to resist heavy blows. Used for diverse jobs such as stringing utility line, mounting cables for bridges, adjusting tension on guy wires, field testing chain, rope or wire and anything requiring precise force or tension measurement. Offers accurate readings from varying sight lines. Dial is mar and fog resistant. Can cancel preset loads up to 20% of capacity. Remains in position to indicate peak load point after load is removed from instrument. Includes users guide and signed calibration card, Dynamometer, shackles and pins, maximum pointer, zero adjust for tare, molded plastic carrying case on 5" models and calibration certificate traceable to NIST.

Part Number	Capacity	Weight	SKU	List
5" Diameter Dial				
30006-0019	500 x 5 lb	15 lb	6864	\$ 1,665.00
30006-0027	1,000 x 10 lb	15 lb	6865	1,580.00
30006-0035	2,000 x 20 lb	15 lb	6866	1,580.00
30006-0043	4,000 x 25 lb	15 lb	6867	1,705.00
30006-0050	5,000 x 50 lb	15 lb	6868	1,665.00
30006-0076	8,000 x 50 lb	15 lb	6870	1,865.00
30006-0084	10,000 x 100 lb	15 lb	6871	1,855.00
30006-0092	15,000 x 100 lb	15 lb	6872	2,130.00
30006-0100	20,000 x 200 lb	15 lb	6873	2,085.00
10" Diameter Dial				
30007-0026	1,000 x 5 lb	26 lb	6875	1,940.00
30007-0034	2,000 x 10 lb	26 lb	6876	1,940.00
30007-0059	5,000 x 20 lb	26 lb	6878	2,030.00
30007-0083	10,000 x 50 lb	26 lb	6881	2,175.00
30007-0109	20,000 x 100 lb	26 lb	6883	2,375.00
30784-0017	30,000 x 200 lb	98 lb	6884	8,205.00
30784-0033	50,000 x 200 lb	98 lb	6886	8,205.00

Service parts

30079-0045 printer 10" dial	1 lb	6882	91.83
30246-0043 printe 5" Dial	1 lb	6896	91.83

DILLON

Quick-Check Tension Meter

Portable and rugged. Designed for outdoor use. Quick Check can be placed on cable, measure its tension and removed in under 5 seconds. Easy to read LED display with full text prompts. Easy to read SOFTKEY interface. Tension units of measure: pound-force, kilogram force, Newtons. Built in averaging. Built in temperature sensor with patented automatic tension adjustment. Sheaves with bearings eliminate friction. Quick Check can be employed in many industries including tower and stack guy wires, pretensioned cable barriers, bridges, elevators, winch rope, prestressed concrete, fall arrest systems, aircraft cables and utilities. Stores calibration for up to 15 unique wire sizes and types. Uses AA batteries and has long life between changes. Includes carrying case.

10"W x 23"D x 3"H

Part Number	Capacity	Weight	SKU	List
AWT05-508112	2,000 x 2 lb	11 lb	6930	\$ 3,070.00
AWT05-508111	10,000 x 10 lb	11 lb	6931	3,130.00

Sheave Select (select at least one)

36309-0085	Code L	Sheave 3/16" to 1/4" wire dia	6932	395.00
36309-0044	Code P	Sheave 3/16" to 1/2" wire dia	6933	361.11
36309-0010	Code S	Sheave 1/4" to 3/4" wire dia	6934	361.11
36309-0101	Code T	Sheave 1/2" to 1" wire dia	6894	361.11

Calibration Select (select at least one)

First wire calibration is included with each Quick Check	6935	no charge
Subsequent calibrations	6936	100.00

Indicate what wire sizes and types to calibrate

Each wire size is calibrated at 4-5 load points and confirmed by a validation run

Quick-Check Tension Meter



Prices are subject to change without notice. Please call for current prices.

Other items are available from the manufacturers, please call for prices.

DILLON

ED junior Dynamometer

Aircraft quality aluminum, easy to position, highly mobile instrument with exceptional strength. 7:1 factor of safety at all capacities and 5:1 on 25K. The EDjunior's design is a direct response to industries that have wanted an extremely well built instrument that could be relied upon for simple yet critical measurements of weight and force. The 6 digit dot matrix display features 1" high numerals for greater visibility. Provides peak detection as well as sustained load readings. SOFTKEY interface provides direct access to setup and display functions without the typical confusing menu structure. 200% safe overload. Distinctive angle body design further eliminates unnecessary weight and streamlines the unit to help prevent binding. Display update rate is 2 times per second. Peak hold sampling rate is 2 times per second. Designed to NEMA4X/IP55 for continuous exterior job site applications as well as in plant use. Calibration traceable to NIST. Includes carry case, manual, calibration card and (2) C cell batteries. Typical battery life is 200 hours. NEMA 4x/IP55.

Part Number	Dillon	Capacity	Weight	SKU	List
EDjr-2.5K	AWT05-506317	2,500 x 2 lb	6 lb	6912	\$ 2,000.00
EDjr-5K	AWT05-506318	5,000 x 5 lb	10 lb	6913	2,120.00
EDjr-10K	AWT05-506319	10,000 x 10 lb	18 lb	6914	2,320.00
EDjr-25K	AWT05-506320	25,000 x 20 lb	47 lb	6915	3,335 00



EDjunior
Dynamometer

DILLON

EDxtreme Dynamometer

Constructed of electroless nickel plated aircraft quality alloy steel. Lower capacity models are anodized aircraft quality aluminum. Allows permanent attachment of centering spacers, which eliminates fumbling during high capacity rigging. 5:1 measure of strength and safety is maintained at all capacities. 200% safe overload capacity. Resolution mode is 1 part in 5,000. Wide angle LCD provides improved readability over a wider viewing angle. RS232 or RS485 communication. Display update rate a 2 times per second. Includes certificate of calibration, manual and (2) C cell batteries. Plastic carrying case included for EDx-2.5K to EDx-100K. Higher capacities include rugged plywood storage crate. Instruments with shackles include centering spacers (EDx-50K & up) and shackle storage crate (EDx-50K to EDx-160K). 9" x 4.6" x 1.8" NEMA 3/IP44

Part Number	Dillon	Capacity	Weight	SKU	List
EDx-2.5K	AWT05-506312	2,500 x 2 lb	13 lb	6920	\$ 2,370.00
EDx 5K	AWT05-506313	5,000 x 5 lb	13 lb	6921	3,080.00
EDx-10K	AWT05-506314	10,000 x 10 lb	22 lb	6922	3,545.00
EDx-25K	AWT05-506315	25,000 x 20 lb	46 lb	6923	4,520.00
EDx-50K	AWT05-506316	50,000 x 50 lb	125 lb	6924	5,640.00



EDxtreme
Dynamometer

Link



TL6000
Tension Link
Scale w/ RF Antenna

TL6000-RF Wireless Tension Link Scale

RF wireless. Aluminum or stainless steel. Cranes, riggers, shipyards, construction sites, surveyors, inspectors and utilities demand cost effective yet technologically advanced solutions for processing, monitoring and controlling overhead loads. +/-0.1% of applied load or +/-1 graduation: whichever is greater, +/- 0.2% or +/- 2 graduations for 25K & higher. Weights are easily viewed with the industry's largest digital 1.2" high LCD readout. The units easy to use membrane switches allow simple, trouble free operation. The TL6000 wireless remote control can communicate with 20 remote tension links simultaneously. The remote can display the weight from a specific tension link or the total weight from all tension links in the system. Can be interfaced with most PLC or notebook computers. Annunciators for low battery, peak hold, set points 1 & 2, lb, kg, tons, metric tons and dekaNewtons. Function keys for ON/OFF, ZERO, PEAK HOLD, MODE. RS232 or RS485 serial output. Efficient micro controller gives up to 800 hours of battery life, wireless remote control models have a reduced operating time. Power is supplied by (2) 9 volt alkaline batteries (not included). NEMA 4X and IP65.

Part Number	Capacity	Weight	SKU	List
TL6000-50,000-RF	50,000 x 50 lb	55 lb	5477	\$ 2,735.00

Options shackles

150103 Top & bottom	50,000 lb	63 lb	3886	895.00
---------------------	-----------	-------	------	--------

Remote Indicators

150114 Dual remote indicator, RF wireless		4 lb	705	995.00
Two indicators, one at tension link and one remote				



150114
RF Wireless
Dual remote indicator

Link

Prices are subject to change without notice. Please call for current prices.

Other items are available from the manufacturers, please call for prices.



TL6000 Tension Link Scale

For crane overload and line tension measurement. High resolution using a 14 bit A/D converter gives +/-0.1% of applied load. All electronics are shock mounted in a weatherproof billet aluminum housing. Components are protected against moisture, dust and rough usage. Weights are easily checked with highly visible 1.2" high LCD digital readout. The units easy to use membrane switches allow simple, trouble free operation. Features include peak hold, set points for relay control and keypad setup. Function keys for ON/OFF, ZERO, PEAK, TARE, MODE. Readings can be displayed in lb, kg, tons, metric tons, and dekaNewtons. RS232 or RS485 serial output in continuous or on demand. Efficient micro controller gives up to 500 hours of battery life. Power is supplied by (2) 9 volt alkaline batteries (not included). NEMA 4X and IP65.

Part Number	Capacity	Weight	SKU	List
TL6000-1,000	1,000 x 1 lb	5 lb	3876	\$ 1,250.00
TL6000-50,000	50,000 x 50 lb	55 lb	3881	2,235.00

Options shackles

150100 Top & bottom	5,000 lb	3 lb	3883	99.00
150103 Top & bottom	50,000 lb	63 lb	3886	895.00

Remote Indicators

189014 RFX Dual remote indicator,		6 lb	566	995.00
Two indicators, one at tension link and one remote				



TL6000
Tension Link Scale



150113
Dual Remote Indicators

Link



TL8500
Tension Link Scale

TL8500 Tension Link Scale

For crane overload and line tension measurement. High resolution using a 14 bit A/D converter gives +/-0.1% of applied load. All electronics are shock mounted in a weatherproof billet aluminum housing. Components are protected against moisture, dust and rough usage. Weights are easily checked with highly visible 1.2" high LCD digital readout. The units easy to use membrane switches allow simple, trouble free operation. Features include peak hold, set points for relay control and keypad setup. Function keys for ON/OFF, ZERO, PEAK, TARE, MODE. Readings can be displayed in lb, kg, tons, metric tons, and dekaNewtons. RS232 or RS485 serial output in continuous or on demand. Efficient micro controller gives up to 400 hours of battery life. Power is supplied by (2) 9 volt alkaline batteries (not included). NEMA 4X and IP65.

Part Number	Capacity	Weight	SKU	List
TL8500-500	500 x 0.5 lb	5 lb	7928	\$ 1,395.00
TL8500-1,000	1,000 x 1 lb	5 lb	7929	1,395.00
TL8500-2,000	2,000 x 2 lb	5 lb	7930	1,395.00
TL8500-5,000	5,000 x 5 lb	5 lb	7931	1,595.00
TL8500-10,000	10,000 x 10 lb	8 lb	7932	1,745.00
TL8500-25,000	25,000 x 20 lb	35 lb	7933	2,395.00
TL8500-50,000	50,000 x 50 lb	55 lb	7934	2,495.00
TL8500-100,000	100,000 x 100 lb	75 lb	7935	4,795.00
TL8500-160,000	160,000 x 200 lb	85 lb	7936	5,095.00

Options shackles

150100 Top & bottom	5,000 lb	3 lb	3883	99.00
150101 Top & bottom	10,000 lb	6 lb	3884	195.00
150102 Top & bottom	25,000 lb	39 lb	3885	605.00
150103 Top & bottom	50,000 lb	63 lb	3886	895.00
150104 Top & bottom	100,000 lb	104 lb	3887	2,925.00

Remote Indicators

189014 RFX Dual remote indicator, Two indicators, one at tension link and one remote		6 lb	566	995.00
---	--	------	-----	--------

Options

150229 Set point relay output control kit		2 lb	770	495.00
---	--	------	-----	--------

ANYLOAD

100RH-WL Tension Link Scale

Wireless tension link or dynamometer with remote indicator. Alloy steel with powder coated finish IP67. Wireless distance 30m. 100 hours operating time. (3)AA batteries, included for link. Wireless indicator IP65 ABS wash down enclosure with LCD and backlight. (3)AA batteries, included for indicator. 2.8"x1.1" Function keys for ON/OFF, ZERO, PEAK, TARE. Units: kg, g, t, lb, Klb, N,kN, oz, user defined. (2)set points for precaution and warning. Auto power off. Auto zero tracking. IP65/IP67.

Part Number	Capacity	Weight	SKU	List
110RH-500kg-WL-FP7	500 x 0.1 kg	2 lb	3327	\$ 1,525.00
110RH-1t-WL-FP7	1,000 x 0.2 kg	2 lb	3328	1,525.00
110RH-2t-WL-FP7	2,000 x 0.5 kg	2 lb	3329	1,525.00
110RH-5t-WL-FP7	5,000 x 1 kg	4 lb	3331	2,050.00
110RH-10t-WL-FP7	10,000 x 2 kg	6 lb	3332	2,339.00
110RH-20t-WL-FP7	20,000 x 5 kg	11 lb	3333	3,126.00
110RH-30t-WL-FP7	30,000 x 10 kg	45 lb	3334	4,467.00
110RH-50t-WL-FP7	50,000 x 10 kg	45 lb	3335	5,400.00
Optional shackles				
SBX-2t	500kg 1t, 2t	2 lb	2527	26.78
SBX-3.25t	1t, 2t, 3t	2 lb	2528	32.14
SBX-4.75t	2t, 3t	2 lb	2529	39.28
SBX-6.5t	5t	2 lb	2530	55.35
SBX-12t	10t	2 lb	2531	100.00
SBX-13.5t	10t	2 lb	2532	132.00
SBX-25t	20t	2 lb	2533	292.00
SBX-35t	30t	2 lb	2534	408.00
SBX-55t	50t	2 lb	2535	919.00
SBX-120t	100t	2 lb	2536	2,135.00
Service Parts				
805HP-WL wireless indicator,		3 lb	3337	683.00



100RH-WL
Tension link



805HP-WL
Wireless indicator

Dynamometer



100ES-WL-HP
Tension link
Stainless steel



805HP-WL
Wireless indicator

ANYLOAD

100ES Tension Link Scale

Wireless tension link or dynamometer with remote indicator. Salt water proof stainless steel IP69. Wireless distance 30m. 100 hours operating time. (3)AA batteries, included for link. Wireless indicator IP65 ABS wash down enclosure with LCD and backlight. (3)AA batteries, included for indicator. 2.8"x1.1" Function keys for ON/OFF, ZERO, PEAK, TARE. Units: kg, g, t, lb, Klb, N,kN, oz, user defined. (2)set points for precaution and warning. Auto power off. Auto zero tracking. IP65/IP69.

Part Number	Capacity	Weight	SKU	List
110ES-1t-WL02	1,000 x 0.2 kg	2 lb	5279	\$ 1,908.00
110ES-2.5t-WL02	2,500 x 0.5 kg	2 lb	5280	1,908.00
110ES-5t-WL02	5,000 x 1 kg	4 lb	5281	2,264.00
110ES-10t-WL02	10,000 x 2 kg	6 lb	5282	2,637.00
110ES-20t-WL02	20,000 x 5 kg	11 lb	5283	2,839.00
110ES-30t-WL02	30,000 x 10 kg	45 lb	5284	3,401.00
110ES-50t-WL02	50,000 x 10 kg	45 lb	5285	7,123.00
110ES-100t-WL02	100,000 x 20 kg	90 lb	5286	13,646.00

Optional shackles

TBX-2t	1t	2 lb	6154	42.85
TBX-2.55t	2.5t	2 lb	6155	55.35
TBX-5t	5t	2 lb	6156	71.42
TBX-12.5t	10t	2 lb	6157	169.00
TBX-21t	20t	2 lb	6158	417.00
TBX-30t	30t	2 lb	6159	507.00
TBX-50t	50t	2 lb	6160	1,482.00

Service Parts

805HP-WL wireless indicator,		3 lb	3337	683.00
------------------------------	--	------	------	--------

Prices are subject to change without notice. Please call for current prices.

Other items are available from the manufacturers, please call for prices.



A&D WEIGHING DIVISION

GX Precision balance

The world's most user friendly balances. Internal calibration mass. Super Hybrid Sensor. Vacuum fluorescent display. Weighing modes: gram, decimal ounce, decimal pound, pound/ounce, carat, pennyweight, troy ounce, grain, momme, percentage, counting, animal weighing. Standard RS232. Includes WinCT software on a CD for loading into your PC. This software will enable the output from the GX to be entered directly into a spread sheet program such as Excel. Splash proof keyboard and display. GLP/GMP/ISO compliance. Display auto power off function. Density calculation mode. Time & Date. Auto self calibration. Standard underhook. Auto power on function. Auto rezero function. Large square weighing pan. Front air bubble leveling. 120 VAC, 50/60 Hz, 7" x 12.5" x 3.4"H.



**GX Series
Precision balance**

Part Number	Capacity	Pan	Weight	SKU	List
GX-1000	1,110g x 0.001g	165 x 165mm	14 lb	7034	3,240.00

Options

GX-04 Comparator output			1 lb	4693	910.00
GX-06 Analog output			1 lb	4694	990.00
GX-11 Glass breeze break for GX-2000 & higher			2 lb	4696	313.00
GX-12 Animal weighing pan for GX-400 & higher			1 lb	4697	210.00
GX-13 Density determination kit			1 lb	4698	720.00
SW:128 Foot switch			1 lb	4699	96.00
AX:073003691-S In use cover for GX GF 200-1000			1 lb	4700	25.00
AX:073003692-S In use cover for GX GF 1200-8000			1 lb	4701	30.76
AX:073007197A In use cover for GXK GFK			0.04 lb	4804	20.00

Service Parts

TB-648 AC adapter 120VAC			1 lb	5340	50.00
PZ:3470-SW switch board GX GF			1 lb	6161	81.00

Prices are subject to change without notice. Please call for current prices.

Other items are available from the manufacturers, please call for prices.

13-01 Pollitt Dr Ext
Fair Lawn NJ 07410
201-797-2718

Totalcomp
Scales & Balances

www.totalcomp.com
sales@totalcomp.com
Fax 201-797-2287



A&D WEIGHING DIVISION



GX-A Balance

GX-A Balance - Internal Calibration

Super hybrid sensor. Reverse backlit LCD display. Software features include Impact Shock Detection, Flow Rate Display and Electronically Controlled Load where an automatic self diagnostic test is run before an internal readability test. Weighing applications: Counting with ACAI, Percent weighing, Density determination, Statistical calculation, Comparator HI/OK/LO, Underhook, Gross/Net/Tare. Weighing Units: g, lb, In-oz, ozt, ct. mom, dwt, gr, pcs, %, SG, user programmable unit. GLP/GMP/GCP compliance, Universal Flex Coms, Password protected. Function keys: ON/OFF, CAL, MODE, SAMPLE, PRINT, REZERO. Anti static breeze break, Front level buddle with LED illumination, key lock security, Fly Thumb Wheel feet. Stainless steel pan. 8.3" (W) x 12.5" (D) x 3.7" (H). 5 year warranty.

Part Number	Capacity	Pan	Weight	SKU	List
GX-203A	220 x 0.001g	128 x 128mm	12 lb	1249	\$ 1,910.00
GX-303A	220 x 0.001g	128 x 128mm	12 lb	1250	2,110.00
GX-403A	420 x 0.001g	128 x 128mm	12 lb	1251	2,240.00
GX-603A	620 x 0.001g	128 x 128mm	12 lb	1252	2,920.00
GX-1003A	1,100 x 0.001g	128 x 128mm	12 lb	1253	3,370.00
GX-1603A	1,620 x 0.001g	128 x 128mm	12 lb	1254	3,830.00
GX-2002A	2,200 x 0.01g	128 x 128mm	12 lb	1255	2,110.00
GX-3002A	3,200 x 0.01g	128 x 128mm	12 lb	1256	2,510.00
GX-4002A	4,200 x 0.01g	128 x 128mm	12 lb	1257	2,625.00
GX-6002A	6,200 x 0.01g	128 x 128mm	12 lb	1258	3,080.00
GX-10002A	10,200 x 0.01g	128 x 128mm	12 lb	1259	4,135.00
GX-6001A	6,200 x 0.1g	128 x 128mm	12 lb	1260	2,340.00
GX-10001A	10,200 x 0.1g	128 x 128mm	12 lb	1261	2,305.00
Service Parts					
	06:4005645 leveling foot		0.03 lb	1228	10.00
	PZ:3470-SW switch board GX GF		1 lb	6161	81.00



A&D WEIGHING DIVISION

FX-i Precision balance

Small size to take up less counter space. 7.6" wide by 10.3" long is less than a sheet of paper 8.5" x 11". Fast stabilization time of 1 second is due to the super hybrid sensor. Comparator function. Vacuum fluorescent display. Weighing units: g, oz, lb, lb-oz, ozt, ct, mom, dwt, GN, tl, tol, mes, pcs, %, MLT. Digital calibration function. Statistical calculation function. Quick USB interface (FXi-02). Standard RS-232 interface. LAN Ethernet interface (FXi-08) with WINCT-Plus Software. 120 VAC adapter. 5 year warranty.

193 W x 262.5 D x 84.5 H mm.
 NTEP Legal for Trade 08-045 = N
 Canada AM-5692 = NC

Part Number	Capacity	Pan	Weight	SKU	List
130mm dia pan					
FX-120i w/breeze break	122g x 0.001g	130mm	8.45 lb	6253	\$ 1,230.00
FX-200i w/breeze break	220g x 0.001g	130mm	8.45 lb	6273	1,275.00
FX-300i w/breeze break	320g x 0.001g	130mm	8.45 lb	6274	1,330.00
FX-500i w/Breeze Break	520g x 0.001g	130mm	8.45 lb	6792	1,550.00

130mm dia pan NTEP Legal for Trade

FX-120iN w/breeze break	122g x 0.001g	130mm	8.45 lb	6737	1,280.00
FX-200iN w/breeze break	220g x 0.001g	130mm	8.45 lb	6738	1,315.00
FX-300iN w/breeze break	320g x 0.001g	130mm	8.45 lb	6310	1,345.00

130mm dia pan Measurement Canada approved

FX-120iNC w/breeze break	122g x 0.001g	130mm	8.45 lb	6788	1,280.00
FX-200iNC w/breeze break	220g x 0.001g	130mm	8.45 lb	6789	1,325.00
FX-300iNC w/breeze break	320g x 0.001g	130mm	8.45 lb	6791	1,345.00

150mm dia pan

FX-1200i	1,220g x 0.01g	150mm	8.45 lb	6275	1,255.00
FX-2000i	2,200g x 0.01g	150mm	8.45 lb	6276	1,325.00
FX-3000i	3,200g x 0.01g	150mm	8.45 lb	6277	1,375.00
FX-5000i	5,200g x 0.01g	150mm	8.45 lb	6798	1,555.00

150mm dia pan NTEP Legal for Trade

FX-1200iN	1,200g x 0.01g	150mm	8.45 lb	6795	1,305.00
FX-2000iN	2,200g x 0.01g	150mm	8.45 lb	6796	1,375.00
FX-3000iN	3,200g x 0.01g	150mm	8.45 lb	6797	1,400.00

150mm dia pan Measurement Canada approved

FX-1200iNC	1,220g x 0.01g	150mm	8.45 lb	6799	1,305.00
FX-3000iNC	3,200g x 0.01g	150mm	8.45 lb	6790	1,400.00
FX-2000iNC	2,200g x 0.01g	150mm	8.45 lb	6713	1,375.00

N suffix is NTEP Legal for Trade.

C suffix is Measurement Canada approved.

Options

FXi-08 Ethernet w/ WinCT software	3 lb	6279	340.00
FXi-09 Built in rechargeable battery	8 lb	6280	380.00
FXi-10 Breeze break small 3.4" h	5 lb	6281	95.00
FXi-11 Breeze break large 7.9" h	6 lb	6282	155.00

Service Parts

FXi-BRACKET NTEP bracket FXi	1 lb	6144	23.00
05:A42208 sealing screw FXi	1 lb	6145	10.00
06:4005645 leveling foot	0.03 lb	1228	10.00
03-4017750 FXi metal pan support arm	0.12 lb	6220	15.00
04:3008433 pan 130mm FX120i-300i	0.14 lb	6128	42.85



FX-300i
Precision balance



Prices are subject to change without notice. Please call for current prices.

Other items are available from the manufacturers, please call for prices.

13-01 Pollitt Dr Ext
 Fair Lawn NJ 07410
 201-797-2718



www.totalcomp.com
 sales@totalcomp.com
 Fax 201-797-2287



A&D WEIGHING DIVISION



**AD-4212A
Production
Weighing System**

AD-4212A Production Weighing System

Made for a production line. Indicator and controls in base unit. Weigh platform in compact separate unit that is located in the production equipment. 2 meter cable connects display with weighing unit. Standard RS232 for computer control. 120 VAC, 50/60 Hz, 7.6" x 12.6" x 3.3"H.

Part Number	Capacity	Pan	Weight	SKU	List
AD-4212A-100	110g x 0.1mg	50 x 50mm	6 lb	5531	\$ 6,185.00
AD-4212A-200	210g x 1mg	50 x 50mm	6 lb	5532	5,435.00
AD-4212A-600	610g x 1mg	50 x 50mm	6 lb	2408	6,000.00
AD-4212A-1000	1,100g x 1mg	50 x 50mm	6 lb	2409	6,222.00

Options

AD-4212A-01 BCD output, factory installed			1 lb	5533	635.00
AD-4212A-07 Extension cable 3 meter			1 lb	5535	190.00
AD-4212A-08 Ethernet interference w/ winCT-Plus			5 lb	5536	330.00
AD-4212A-19 SS breeze break, 200g only			1 lb	5537	120.00
AD-4212A-20 Metal leveling feet			1 lb	5538	82.00



A&D WEIGHING DIVISION



**FZ-120iWP
Precision balance
Water proof/Dust proof**

FZ-iWP Water Proof/Dust proof

Compact Super Hybrid Sensor (SHS). Internal calibration. Digital calibration. IP65 water proof/dust proof. Comparator function. SCF- Statistical Calculation Function. Weighing Units: g, lb, oz, lb-oz, ozt, ct, mom, dwt, GN, tl, tol, mes, pcs, %, MLT. Standard RS232C interface. Breeze Break 3.4" high. 5 year warranty.

Part Number	Capacity	Pan	Weight	SKU	List
FZ-120iWP w/ Breeze Break	122 x 0.001g	5.12" dia	24 lb	7563	\$ 1,990.00
FZ-200iWPw/ Breeze Break	220 x 0.001g	5.12" dia	24 lb	7564	2,070.00
FZ-300iWPw/ Breeze Break	320 x 0.001g	5.12" dia	24 lb	7565	2,235.00
FZ-1200iWP	1,220 x 0.01g	5.91" dia	24 lb	7566	1,990.00
FZ-2000iWP	2,000 x 0.01g	5.91" dia	24 lb	7567	2,070.00
FZ-3000iWP	3,000 x 0.01g	5.91" dia	24 lb	7568	2,240.00

Options

AX: 073009456 FZ In use cover			1 lb	7005	20.00
TB: 648 AC adapter			1 lb	5340	50.00



A&D WEIGHING DIVISION

FZ-i Precision balance

Compact Super Hybrid Sensor (SHS). Internal calibration. Digital calibration. Comparator function. SCF- Statistical Calculation Function. Weighing Units: g, lb, oz, lb-oz, ozt, ct, mom, dwt, GN, tl, tol, mes, pcs, %, MLT. Standard RS232C interface. Breeze Break 3.4" high. 5 year warranty.

Part Number	Capacity	Pan	Weight	SKU	List
FZ-120i w/ Breeze Break	122 x 0.001g	5.12" dia	12 lb	7557	\$ 1,440.00
FZ-200i w/ Breeze Break	220 x 0.001g	5.12" dia	12 lb	7558	1,515.00
FZ-300i w/ Breeze Break	320 x 0.001g	5.12" dia	12 lb	7559	1,555.00
FZ-500i w Breeze Break	520 x 0.001g	5.12" dia	12 lb	7573	1,770.00
FZ-1200i	1,220 x 0.01g	5.91" dia	12 lb	7560	1,495.00
FZ-2000i	2,200 x 0.01g	5.91" dia	12 lb	7561	1,545.00
FZ-3000i	3,000 x 0.01g	5.91" dia	12 lb	7562	1,590.00
FZ-5000i	5,200 x 0.01g	5.91" dia	12 lb	7574	1,815.00

Options

AX: 073009456 FZ In use cover	1 lb	7005	20.00
TB: 648 FZ AC adapter	1 lb	5340	50.00



FZ-300i
Precision balance



A&D WEIGHING DIVISION

FX-iWP Precision balance

Compact. Miniaturized Super Hybrid Sensor (SHS). B5 size footprint. Response indicator function. ACAI-Automatic Counting Accuracy Improvement. Comparator function. Vacuum fluorescent display. Weighing units: g, pcs, %, oz, ozt, ct, mom, dwt, GN, tl, mes, MLT. Percent mode function. Animal weighing function. Shock absorber function. Statistical Calculation Function. Auto power on/off function. GLP/GMP/GCP/ISO compliant. Built in rechargeable battery. AC Adapter. 5 year warranty. 193 W x 262.5 D x 84.5 Hmm

Part Number	Capacity	Pan	Weight	SKU	List
FX-120iWP	122 x 0.001g	130 x 130mm	8 lb	4967	\$ 1,620.00
FX-200iWP	220 x 0.001g	130 x 130mm	8 lb	4968	1,705.00
FX-300iWP	320 x 0.001g	130 x 130mm	8 lb	4969	1,820.00
FX-1200iWP	1,220 x 0.01g	150 x 150mm	10 lb	4970	1,610.00
FX-2000iWP	2,200 x 0.01g	150 x 150mm	10 lb	4971	1,705.00
FX-3000iWP	3,200 x 0.01g	150 x 150mm	10 lb	4972	1,815.00

Options

FXi-02 USB interface w/ cable	2 lb	6278	105.00
FXi-08 Ethernet w/ WinCT software	3 lb	6279	340.00
FXi-09 Built in rechargeable battery	8 lb	6280	380.00
FXiWP-10 Breeze break small 3.4" h	5 lb	6334	95.00
FXiWP-11 Breeze break large 7.9" h	6 lb	6335	155.00

Service Parts

AX:00A34086-2 protective cover FA FX	1 lb	6285	15.00
AX:073000313 protective cover HF	1 lb	6286	15.00
06:4005645 leveling foot	0.03 lb	1228	10.00



FX-120iWP
Precision balance

Precision

Prices are subject to change without notice. Please call for current prices.

Other items are available from the manufacturers, please call for prices.

13-01 Pollitt Dr Ext
Fair Lawn NJ 07410
201-797-2718

Totalcomp
Scales & Balances

www.totalcomp.com
sales@totalcomp.com
Fax 201-797-2287



A&D WEIGHING DIVISION



GF-A Precision Balance

GF-A Precision Balance

Super hybrid sensor. Reverse backlit LCD display. Software features include Impact Shock Detection, Flow Rate Display and Electronically Controlled Load where an automatic self diagnostic test is run before an internal readability test. Weighing application: Counting with ACAI, Percent weighing, Density determination, Statistical calculation, Comparator HI/OK/LO, Underhook, Gross/Net/Tare. Weighing Units: g, lb, In-oz, ozt, ct, mom, dwt, gr, pcs, %, SG, user programmable unit. GLP/GMP/GCP compliance, Universal Flex Coms, Password protected. Function keys: ON/OFF, CAL, MODE, SAMPLE, PRINT, REZERO. Anti static breeze break, Front level bubble with LED illumination, key lock security, Fly Thumb Wheel Feet.

Part Number	Capacity	Pan	Weight	SKU	List
GF-123A	122 x 0.001g	128 x 128mm	12 lb	2063	\$ 1,405.00
GF-203A	220 x 0.001g	128 x 128mm	12 lb	2064	1,545.00
GF-303A	320 x 0.001g	128 x 128mm	12 lb	2065	1,745.00
GF-403A	420 x 0.001g	128 x 128mm	12 lb	2066	1,890.00
GF-603A	620 x 0.001g	128 x 128mm	12 lb	2067	2,225.00
GF-1003A	1,100 x 0.001g	128 x 128mm	12 lb	2068	2,675.00
GF-1603A	1,620 x 0.001g	128 x 128mm	12 lb	2069	3,440.00
GF-1202A	1,220 x 0.01g	128 x 128mm	12 lb	2070	1,565.00
GF-2002A	2,200 x 0.01g	128 x 128mm	12 lb	2071	1,605.00
GF-3002A	3,200 x 0.01g	128 x 128mm	12 lb	2072	1,660.00
GF-4002A	4,200 x 0.01g	128 x 128mm	12 lb	2073	2,130.00
GF-6002A	6,200 x 0.01g	128 x 128mm	12 lb	2074	2,600.00
GF-10002A	10,200 x 0.01g	128 x 128mm	12 lb	2075	3,210.00
GF-6001A	8,300 x 0.1g	128 x 128mm	12 lb	2076	1,770.00
GF-10000A	10,200 x 0.1g	128 x 128mm	12 lb	2077	1,855.00



A&D WEIGHING DIVISION

GF-P Precision balance

Tough, die-cast aluminum housing. Ideal for pill counting and compounding. Fast, Super Hybrid Sensor (SHS). Removeable stainless steel pan. IP54 splash proof/dust proof stainless steel weighing pan. Large, bright vacuum fluorescent display. Multiple weighing modes. One second response time. Data memory function. Underhook. WinCT data collection software. Quick reference operation card. RS232C standard. GLP/LIMS/ISO compliance. 5 year warranty.

NTEP Legal for Trade 04-077P

Part Number	Capacity	Pan	Weight	SKU	List
GF-200P	200 x 0.001g	5" x 5"	16 lb	7575	\$ 1,565.00
GF-300P	310 x 0.001g	5" x 5"	16 lb	7576	1,860.00

Options

GX-02 USB option for GF & GX	1 lb	7577	175.00
TB: 648 AC adapter	1 lb	5340	50.00

Service Parts

08:3003976 Keysheet GF	1 lb	7510	18.00
------------------------	------	------	-------



GF-P Precision balance





ALC Precision balance

Stainless steel weighing platform. State of the art technology provides accuracy, repeatability and outstanding performance at remarkably affordable prices. Large LCD display. Keys are: CAL, ON/OFF, ZERO, PRINT, F. Piece counting. Percent weighing for solids, moisture loss, formulation, quality control. Averaging for unstable ambient conditions. Net totaling for formulation. User selectable two unit toggling. Advanced microprocessor for accurate weighing results, digital filtering and fast stabilization. RS 232 bi-directional interface for connection to computer or printer. Lock down capability. Four selectable application programs. 20 different weighing modes. Simple one button external calibration. 120 VAC

Part Number	Capacity	Pan	Weight	SKU	List
ALC-150.3	150g x 1mg	3.95" dia	6 lb	6818	\$ 920.00
ALC-1100.2	1,100g x 0.01g	5.9" dia	5 lb	6821	920.00



ALC Precision balance



EBL Eclipse Precision Balance

Vivid backlit LCD display is easily visible in any lighting conditions. Backlight is adjustable. weight pan is 304 stainless steel. Draft shield with models having 0.001g readability. Metal housing for rugged use. Sealed keypad for dirt and spills. USB and RS-232 interface. Level indicator and adjustable feet. 120 VAC adapter included. Weighing units: g, hg, ct, gn, n, lb, oz, ozt, mm, tl.t,tl.h, tl.s, ti.t, custom unit. Overall 8.7" x 12.2" x 10.6" H. One year Warranty.

Part Number	Capacity	Pan	Weight	SKU	List
External Calibration					
EBL 12001e	12,000g x 0.1g	15.7"x11.8"	17 lb	852	\$ 2,335.00
EBL 16001e	16,000g x 0.1g	15.7"x11.8"	17 lb	853	2,825.00
EBL 22001e	22,000g x 0.1g	15.7"x11.8"	17 lb	854	3,795.00
EBL 32001e	32,000g x 0.1g	15.7"x11.8"	17 lb	855	4,530.00

With Pillar

EBL 12001P	12,000g x 0.1g	15.7"x11.8"	18 lb	856	2,385.00
EBL 16001P	16,000g x 0.1g	15.7"x11.8"	18 lb	857	2,940.00
EBL 22001P	22,000g x 0.1g	15.7"x11.8"	18 lb	858	3,925.00
EBL 32001P	32,000g x 0.1g	15.7"x11.8"	18 lb	859	4,665.00



EBL



PGL Precision Balance

Service parts only for Adam PGL.

Part Number	Capacity	Pan	Weight	SKU	List
Options					
3074010266	RS-232 cable		1 lb	7068	35.00
Service Parts					
302409160	adapter 120 VAC		1 lb	252	53.33



PGL Precision Balance

Precision

Prices are subject to change without notice. Please call for current prices.

Other items are available from the manufacturers, please call for prices.



HC B Highland Precision balance

HC B Highland Precision balance

HandiCal internal calibration for fast and accurate readings. Three point ShockProtect protection designed for the ultimate in performance reliability. ABS plastic with stainless steel platform. 6 digit, 0.6" backlit LCD display. Left and right tare keys. Applications include weighing, percent weighing, parts counting, totalization/accumulation. Audible overload indicator. Lock down mounting slot for Kensington type lock and cable. Internal rechargeable battery with auto power off and low battery indicator. Capacity tracker. Removable draft shield. USB and RS-232 bidirectional interface included for easy connection to computers and printers. 12VDC 800mA adapter.

NTEP Legal for Trade

Part Number	Capacity	Pan	Weight	SKU	List
Non-NTEP					
HC B123	120 x 0.001g	4.7"dia	5 lb	5299	\$ 585.00
HC B153	150 x 0.005g	4.7"dia	5 lb	5300	510.00
HC B302	300 x 0.01g	4.7"dia	5 lb	5301	510.00
HC B602H	600 x 0.01g	4.7"dia	5 lb	5302	635.00
HC B602	600 x 0.02g	4.7"dia	5 lb	5303	510.00
HC B1002	1,000 x 0.01g	4.7"dia	5 lb	5304	745.00
HC B1502	1,500 x 0.05g	4.7"dia	5 lb	5305	590.00
HC B2202	2,200 x 0.05g	4.7"dia	5 lb	5327	880.00
HC B3001	3,000 x 0.1g	4.7"dia	5 lb	5306	510.00
HC B6001	6,000 x 0.1g	4.7"dia	5 lb	5328	705.00
NTEP Legal for Trade					
HC B103aM	100 x 0.001g	4.7"dia	8 lb	167	745.00
HC B302aM	300 x 0.05g	4.7"dia	8 lb	168	625.00
HC B602aM	600 x 0.01g	4.7"dia	8 lb	169	655.00
HC B1202aM	1,200 x 0.01g	4.7"dia	8 lb	170	765.00
HC B3001aM	3,000 x 0.5g	4.7"dia	8 lb	171	635.00
HC B5001aM	5,000 x 0.5g	4.7"dia	8 lb	172	655.00
Options					
308232030 In use cover			1 lb	5298	20.00
Service Parts					
302409160 adapter 120VAC			1 lb	252	53.30



EP Explorer Pro Precision balance

Explorer Pro balances are available with internal auto calibration or internal calibration. Weighing units: g, mg, kg, lb, oz, ozt, ct, dwt, taels(3), mommes, gn, ti, N, user definable custom unit. High resolution dot matrix alphanumeric display. User can select data fields to show on display including dual weighing units and ten messages. Configurable in English, French, Spanish, German and Italian. Applications include: Gross net tare weighing, GLP, GMP, parts counting, animal weighing, check weighing, filling, percent function, under hook for density and specific gravity. Cursor keys for ease in operation. RS232 interface. Adjustable filter for stabilization time. Stainless steel pan. 2 Year warranty. 100-120 VAC adapter, 8.3" x 14.5" x 14.5"H.



**EP612
Precision balance**

Part Number	Capacity	Pan	Weight	SKU	List
Without internal calibration weight					
EP413	410g x 0.001g	4.7" dia	19 lb	3338	\$ 2,376.00
Options					
80850043	Security Device up to 8kg		1 lb	1632	305.00
80253384	Density determination kit		3 lb	2794	1,022.00
CBM-910	Impact printer, 42 column		5 lb	7426	395.00
80500570	RS232 cable to printer		1 lb	7429	193.00
Service Parts Explorer Pro					
83020938	line cord 120 VAC		1 lb	601	29.00

Prices are subject to change without notice. Please call for current prices.

Other items are available from the manufacturers, please call for prices.

OHAUS®



EX223
Precision balance



EX Explorer Precision balance

Intelligent performance. Intuitive software. Ingenious draftshield. Practical touchless sensors. 5.7" full color VGA graphic display. Touch screen. Weighing applications for: Weighing, Percent Weighing, Check Weighing, Dynamic/Animal Weighing, Filling, Totalization, Formulation, Differential Weighing, Density Determination, Peak Hold, Ingredient Costing, Pipette Adjustment, SQC. Weighing units for: gram, milligram, kilogram, carat, ounce, ounce troy, pound, pennyweight, grain, newton, momme, mesghal, Hong Kong tael, Singapore tael, Taiwan tael, tical, tola, baht, 3 custom units. RS232, USB communication. 100-240 VAC adapter. 9.1"W x 15.5"D x 13.8"H. 2 year warranty.

Part Number	Capacity	Pan	Weight	SKU	List
AutoCal					
EX223	220g x 0.001g	5.1" dia	22 lb	7760	\$ 3,538.00
EX423	420g x 0.001g	5.1" dia	22 lb	7761	4,137.00
EX623	620g x 0.001g	5.1" dia	22 lb	7762	5,055.00
EX1103	1,100g x 0.001g	5.1" dia	22 lb	7763	5,925.00
EX2202	2,200g x 0.01g	7.5" x 7.9"	16 lb	7764	3,826.00
EX4202	4,200g x 0.01g	7.5" x 7.9"	16 lb	7765	4,398.00
EX6202	6,202g x 0.01g	7.5" x 7.9"	17 lb	7766	4,991.00
EX10202	10,200g x 0.01g	7.5" x 7.9"	17 lb	7767	5,920.00
EX6201	6,200g x 0.1g	7.5" x 7.9"	17 lb	7768	4,150.00
EX10201	10,200g x 0.1g	7.5" x 7.9"	17 lb	7769	4,547.00

NTEP Legal for Trade 12-012 I/II

EX423N	420g x 0.001g	5.1" dia	22 lb	7569	4,611.00
EX1103N	1,100g x 0.001g	5.1" dia	22 lb	7570	6,468.00
EX4202N	4,200g x 0.01g	7.5" x 7.9"	16 lb	7571	4,829.00
EX10202N	10,200g x 0.01g	7.5" x 7.9"	17 lb	7572	6,468.00
EX10201N	10,200g x 0.1g	7.5" x 7.9"	17 lb	7620	4,997.00

Tradition Calibration (not AutoCal)

EX223/E	220g x 1mg	5.1" dia	22 lb	6957	3,036.00
EX423/E	420g x 1mg	5.1" dia	22 lb	6958	3,670.00
EX2202/E	2,200 x 0.01g	7.5" x 7.9"	16 lb	6959	3,312.00
EX4202/E	4,200g x 0.01g	7.5" x 7.9"	16 lb	6960	3,861.00
EX6202/E	6,200g x 0.01g	7.5" x 7.9"	16 lb	6961	4,420.00
EX6201/E	6,200g x 0.1g	7.5" x 7.9"	16 lb	6962	3,549.00

Service Parts

83033684 Top cover			1 lb	424	32.00
83033652 foot kit sp EX(4)			1 lb	346	97.00

Prices are subject to change without notice. Please call for current prices.

Other items are available from the manufacturers, please call for prices.

OHAUS®

AX Adventurer Precision Balance

Color Touchscreen with wide viewing angle. Ingenious draftshield opens wide on both sides. Automatic internal calibration system that calibrates the balance daily. Real time clock with GLP/GMP data. Application modes for Weighing, Dynamic Weighing, Display Hold, Parts Counting, Density Determination, Totalization/Statistic, Percent Weighing, Check Weighing and Formulation. Weighing units for: gram, milligram, mesgal, Newton, ounce, pennyweight, baht, carat, grain, pound, Hong Kong tael, Singapore tael, Taiwan tael, tical, tola, ounce troy, 1 custom unit. RS232, (2)USB ports. 100-240 VAC adapter. 9.05"W x 13.93"D x 13.39"H. 2 year warranty.



AX124
Precision Balance

Part Number	Capacity	Pan	Weight	SKU	List
AutoCal.					
AX223	220g x 0.001g	130mm dia	18 lb	8226	2,384.00
AX423	420g x 0.001g	130mm dia	18 lb	8227	2,875.00
AX523	520g x 0.001g	130mm dia	18 lb	8228	3,140.00
AX622	620 x 0.01g	175 x 195mm	15 lb	3966	1,807.00
AX1502	1,520g x 0.01g	175 x 195mm	15 lb	8229	2,205.00
AX2202	2,200g x 0.01g	175 x 195mm	15 lb	8230	2,349.00
AX4202	4,200g x 0.01g	175 x 195mm	15 lb	8231	2,949.00
AX5202	5,200g x 0.01g	175 x 195mm	15 lb	8232	3,341.00
AX4201	4,200 x 0.1g	175 x 195mm	28 lb	3973	1,946.00
AX8201	8,200g x 0.1g	175 x 195mm	15 lb	8233	2,274.00
External Calibration					
AX223/E	220g x 0.001g	130mm dia	18 lb	3963	1,893.00
AX423/E	420g x 0.001g	130mm dia	18 lb	3964	2,337.00
AX523/E	520g x 0.001g	130mm dia	18 lb	3965	2,574.00
AX422/E	420g x 0.01g	175 x 195mm	12 lb	3967	1,328.00
AX822/E	420g x 0.01g	175 x 195mm	12 lb	3968	1,565.00
AX1502/E	1,520g x 0.01g	175 x 195mm	49 lb	3969	1,692.00
AX2202/E	2,200g x 0.01g	175 x 195mm	47 lb	3970	1,785.00
AX4202/E	4,200g x 0.01g	175 x 195mm	47 lb	3971	2,372.00
AX2201/E	2,200g x 0.1g	175 x 195mm	28 lb	3972	1,495.00
AX4201/E	4,200g x 0.1g	175 x 195mm	28 lb	3974	1,692.00
AX8201/E	8,200 x 0.1g	175 x 195mm	28 lb	3975	1,893.00
NTEP Legal for Trade					
AX423N	420g x 0.001g	130mm dia	18 lb	5329	3,070.00
NTEP Legal for Trade , AutoCal					
AX223N/E	220g x 0.001g	130mm dia	18 lb	6532	2,096.00
AX423N/E	420g x 0.001g	130mm dia	18 lb	6533	2,499.00
AX523N/E	520g x 0.001g	130mm dia	18 lb	6534	2,775.00
AX622N/E	620g x 0.01g	175 x 195mm	18 lb	6535	1,622.00
AX1502N/E	1,520g x 0.01g	175 x 195mm	18 lb	6536	1,830.00
AX2202N/E	2,200g x 0.01g	175 x 195mm	18 lb	6537	2,032.00
AX4202N/E	4,200g x 0.01g	175 x 195mm	18 lb	6538	2,574.00
AX8201N/E	8,200g x 0.1g	175 x 195mm	18 lb	6539	2,032.00
Options					
30064203 SF40A Dot Matrix printer, includes RS232 cable			2 lb	1754	1,303.00
80500525 Cable to IBM 9 pin serial			1 lb	3047	254.00
83021085 USB interface w/cable			1 lb	8234	254.00
Service Parts					
30111779 main board AX			1 lb	6527	563.00
30111768 keypad AX			1 lb	6528	51.00
30111777 In use cover AX			0.83 lb	3639	40.00

Prices are subject to change without notice. Please call for current prices.

Other items are available from the manufacturers, please call for prices.

13-01 Pollitt Dr Ext
Fair Lawn NJ 07410
201-797-2718

 **Totalcomp**
Scales & Balances

www.totalcomp.com
sales@totalcomp.com
Fax 201-797-2287

OHAUS®

PX Pioneer Precision Balance

Metal base, plastic top housing, removable stainless steel pan, Glass draftshield, integrated weigh-below hook, security bracket, calibration lock and in-use cover. Backlit liquid crystal display LCD. Weighing applications for: Basic Weighing, Parts Counting, Percent Weighing, Animal Weighing, Density Determination. Weighing units for: gram, milligram, kilogram, ounce, pound, carat, pennyweight, Troy ounce, grain, newton, momme, mesghal, Hong Kong tael, Singapore tael, Taiwan tael, tical, tola, baht, 1 custom unit. RS232, USB communication. 100-240 VAC adapter (included), 21.7"W x 15.2"D x 11.5"H. 2 year warranty.



PX163
Analytical Balance

Part Number	Capacity	Pan	Weight	SKU	List
External Calibration					
PX163/E	160g x 1mg	4.72" dia	15.4 lb	3666	\$ 1,270.00
PX323/E	320g x 1mg	4.72" dia	15.4 lb	3667	1,478.00
PX523/E	520g x 1mg	4.72" dia	15.4 lb	3668	1,824.00
PX1602/E	1,600g x 0.01g	7.09" dia	11.0 lb	1652	1,223.00
PX2202/E	2,200g x 0.01g	7.09" dia	11.0 lb	1653	1,340.00
PX3202/E	3,200g x 0.01g	7.09" dia	11.0 lb	1654	1,611.00
PX4202/E	4,200g x 0.01g	7.09" dia	11.0 lb	1655	1,830.00
PX2201/E	2,200g x 0.1g	7.09" dia	11.0 lb	1656	1,137.00
PX4201/E	4,200g x 0.1g	7.09" dia	11.0 lb	1657	1,310.00
Internal Calibration					
PX163	160g x 1mg	4.72" dia	15.4 lb	3660	1,593.00
PX323	320g x 1mg	4.72" dia	15.4 lb	3661	1,789.00
PX523	520g x 1mg	4.72" dia	15.4 lb	3662	2,151.00
PX1602	1,600g x 0.01g	7.09" dia	11.0 lb	1646	1,517.00
PX2202	2,200g x 0.01g	7.09" dia	11.0 lb	1647	1,645.00
PX3202	3,200g x 0.01g	7.09" dia	11.0 lb	1648	1,934.00
PX4202	4,200g x 0.01g	7.09" dia	11.0 lb	1649	2,169.00
PX2201	2,200g x 0.1g	7.09" dia	11.0 lb	1650	1,403.00
PX4201	4,200g x 0.1g	7.09" dia	11.0 lb	1651	1,588.00
Service Parts					
30372521 function label EN PX			0.02 lb	1661	19.00
30529325 AC adapter 100-240VAC 10W 12VDC			0.44 lb	1664	65.00

OHAUS®

PA Pioneer Precision balance

Service parts for PA Pioneer Precision balance.

Part Number	Weight	SKU	List
Service Parts			
83020241 weighing pan 90mm PA	0.4 lb	1681	\$ 112.00

OHAUS®

AV Adventurer Pro Precision balance

Service parts for AV Adventurer Pro Precision balance.

Part Number	Weight	SKU	List
Service Parts			
46001724 AC adapter 120VAC w/o prong set	1 lb	6164	\$ 67.00
46001776 Prong set, US only	1 lb	6226	29.00
46001780 Prong set, International	1 lb	714	29.00



AV412
Precision balance

Prices are subject to change without notice. Please call for current prices.

Other items are available from the manufacturers, please call for prices.



NV Navigator

Two touchless sensors which free up your hands for handling samples and minimizing wear and tear on the keypad. 6 digit, 7 segment with white LED backlight or red LED. 4 mechanical keys, raised with tactile feedback. Weighing units for: gram, kilogram, pound, ounce (decimal or fractional), pound (decimal or fractional), ounce troy, grain, newton, carat, pennyweight, Hong Kong tael, Taiwan teal, Singapore teal, tical, tola. Application modes for: Weighing, Percent Weighing, Parts Counting, Check Weighing, Display Hold, Accumulate/Totalize. Over-accept-under LCD or LED annunciators. Front mounted level bubble with illumination. Adjustable leveling feet with skid resistant rubber pads. Full capacity by subtraction tare range. User selectable external span or linearity calibration, digital with external weight. 12VDC AC adapter included or (4) AA batteries (not included). 8.03"W x 8.34"D x 5.27"H.



Navigator

Part Number	Capacity	Pan	Weight	SKU	List
NV123	120g x 0.001g	3.7" dia	3.3 lb	6365	\$ 520.00
NV223	220g x 0.001g	3.7" dia	3.3 lb	6366	579.00
NV323	320g x 0.001g	3.7" dia	3.3 lb	6367	635.00
NV222	220g x 0.01g	5.7" dia	3.3 lb	2139	468.00
NV422	420g x 0.01g	5.7" dia	3.3 lb	2140	595.00
NV622	620g x 0.01g	5.7" dia	3.3 lb	6368	607.00
NV1202	1,200g x 0.01g	7.5" x 5.7"	3.3 lb	6369	676.00
NV2202	2,200g x 0.01g	7.5" x 5.7"	3.3 lb	6370	911.00
NV3202	3,200g x 0.01g	7.5" x 5.7"	3.3 lb	6371	745.00
NV221	220g x 0.1g	7.5" x 5.7"	3.3 lb	2141	274.00
NV621	620g x 0.1g	7.5" x 5.7"	3.3 lb	2142	401.00
NV1201	1,200g x 0.1g	7.5" x 5.7"	3.3 lb	2143	454.00
NV2201	2,200g x 0.1g	7.5" x 5.7"	3.3 lb	2144	504.00
NVT2201	2,200g x 0.1g	9.1" x 6.9"	5.1 lb	2145	504.00
NVT4201	4,200g x 0.1g	9.1" x 6.9"	5.1 lb	2146	630.00
NVT2200	2,200g x 1g	9.1" x 6.9"	5.1 lb	2147	476.00
NVT6200	6,200g x 1g	9.1" x 6.9"	5.1 lb	2148	630.00
NVT12000	12,200g x 1g	9.1" x 6.9"	5.1 lb	2149	681.00
NVT22000	22,200g x 1g	9.1" x 6.9"	5.1 lb	2150	814.00
NVT6201	6,200g x 0.1g	9.1" x 6.9"	5.1 lb	6372	634.00
NVT10201	10,200g x 0.1g	9.1" x 6.9"	5.1 lb	6373	669.00
Options					
830332108	USB interface			6163	220.00
830332107	RS232 interface			6162	220.00
830332109	Ethernet interface			1747	220.00
30467963	Carrying case			1749	145.00
30467987	Adapter w/ships (5) countries(EU,US,UK,AU,KR)			2875	53.00
30064203	SF40A Dot Matrix printer, includes RS232 cable	2 lb		1754	1,303.00



AX Adventurer Precision balance

Service parts only for Adventurer

Part Number	Weight	SKU	List
Service Parts			
46001724	AC adapter 120VAC w/o prong set	1 lb	6164 67.00
46001776	Prong set, US only	1 lb	6226 29.00
30111777	in use cover for AX w/o draft shield	1 lb	3639 40.00
30111792	in use cover for AX w/ m draft shield	1 lb	3715 40.00



ARC120 Precision balance

Prices are subject to change without notice. Please call for current prices.

Other items are available from the manufacturers, please call for prices.

Precision



**WLC
Bench**



WLC Precision

Stainless steel weighing platter. Fast and precise mass determination in laboratory and industrial conditions. Excellent in areas with no access to mains. Backlit LCD display. Counting pieces. Checkweighing and percentage. Animal weighing. Caps lock of max indication. Measurement in Newton. WLCA2 have the option of weighing loads outside the weighing platform (under hook weighing). Includes internal rechargeable battery and RS232 output.

Part Number	Capacity	Platform	Weight	SKU	List
WLC2/A2	2kg x 0.01g	7.7" x 7.7"	5 lb	7617	\$ 618.00
WLC10/A2	10kg x 0.1g	7.7" x 7.7"	9 lb	7621	618.00
WLC20/A2	20kg x 0.1g	7.7" x 7.7"	9 lb	7622	655.00



**WTC
Bench**



WTC Precision

Internal rechargeable battery for portable operation. Fast and precise mass determination in laboratory and industrial conditions. Stainless steel weighing pan. Backlit LCD display. Checkweighing, Parts Counting, Percent, Totalizing, Animal weighing, Peak hold. Includes internal rechargeable battery. Optional RS232 output. IP43.

Part Number	Capacity	Platform	Weight	SKU	List
WTC200	200 g x 0.001 g	100mm dia	3.88 lb	67	\$ 474.00
WTC600	600 g x 0.01 g	128x128mm	3.88 lb	122	397.00
WTC2000	2,000 g x 0.01 g	128x128mm	3.88 lb	68	448.00
WTC3000	3,100 g x 0.1 g	128x128mm	3.88 lb	123	495.00



Midrics Level 1 & 2 Precision balance

Rugged construction. 2 display and indicator units. 4 adjustable feet. Level indicator. 10 weighing ranges from 3kg to 3t.

Midrics 1 for simple weighing tasks.

Midrics 2 with 10 key touch pad and applications programs. Applications include: counting, checkweighing, classification, totalizing, net-total formulation, animal weighing, percent weighing, neutral measurement.

Stainless steel. Indicator is stainless steel and IP65. Stainless steel versions are suited for industrial use in wet environments.

Part Number	Capacity	Pan	Weight	SKU	List
Midrics Level 1 Weigh Only					
MW1P1U-3DC-L	3kg x 0.002kg	12.6" x 9.4"	21 lb	4943	\$ 1,343.00
MW1P1U-6DC-L	6kg x 0.005kg	12.6" x 9.4"	21 lb	4944	1,343.00
MW1P1U-15DC-L	15g x 0.001kg	12.6" x 9.4"	21 lb	4945	1,343.00
MW1P1U-30ED-L	30kg x 0.002kg	15.7" x 11.8"	30 lb	4946	1,420.00
MW1P1U-60ED-L	60kg x 0.005kg	15.7" x 11.8"	30 lb	4947	1,420.00
MW1P1U-60FE-L	60kg x 0.005kg	19.7" x 15.7"	37 lb	4948	1,635.00
MW1P1U-150FE-L	150kg x 0.01kg	19.7" x 15.7"	37 lb	4949	1,635.00
Midrics Level 2 Weight & Keypad					
MW2P1U-3DC-L	3kg x 0.0002g	12.6" x 9.4"	21 lb	4951	1,348.00
MW2P1U-6DC-L	6kg x 0.0005kg	12.6" x 9.4"	21 lb	4952	1,348.00
MW2P1U-15DC-L	15kg x 0.001kg	12.6" x 9.4"	21 lb	4953	1,348.00
MW2P1U-30ED-L	30kg x 0.002kg	15.7" x 11.8"	30 lb	4954	1,409.00
MW2P1U-60ED-L	60kg x 0.005kg	15.7" x 11.8"	30 lb	4955	1,409.00
MW2P1U-60FE-L	60kg x 0.01kg	19.7" x 15.7"	37 lb	4956	1,666.00
MW2P1U-150FE-L	150kg x 0.01kg	19.7" x 15.7"	37 lb	4957	1,666.00
Options					
YDH01CWSUS 13" Column SS column			4 lb	4962	195.00
YDH02CWSUS 19.7" High SS column			5 lb	4964	210.00
YDH03CWSUS 29.5" SS Column			7 lb	4966	241.00



Midrics Level 1 Weigh only Precision balance



Midrics Level 2 Precision balance



CP Precision balance

Service parts only for Sartorius CP.

Part Number	Weight	SKU	List
Service Parts			
6971500 Power supply 110VAC	3 lb	3054	\$ 667.00
YDP03-OCE Data printer with statistics & time/date*	5 lb	3751	980.00

* Order printer power supply separately

Prices are subject to change without notice. Please call for current prices.

Other items are available from the manufacturers, please call for prices.



Practum

Unmatched reliability with the world class weighing instrument. Fast and easy data transfer. Touch screen with Sartorius graphical user interface. Overload protection for years of reliability. Glass level indicator with air bubble for centering. External calibration. Standard built in applications for: Weighing, Density, Percentage, Checkweighing, Peak Hold, COunting, Unstable Conditions. Selectable weighig units for: Gram, Kilogram, Carat, Pound, Ounce, Troy Ounce, Honk Kong Tael, Singapore Tael, Taiwan Tael, Grain, Pennyweights, Milligram, Parts Per Pound, China Tael, Mommnes, Austrian Carat, Tola, Baht, Mesghal and Newton. USB port. 100-240 VAC, 50/60 Hz.



Practum 2012-1S
Precision balance



Practum 213-1S
Precision balance

Part Number	Capacity	Pan	Weight	SKU	List
Practum 124-1S	120g x 0.1mg	3.5"	11 lb	7605	\$ 2,530.00
Practum 224-1S	220g x 0.1mg	3.5"	11 lb	7606	2,780.00
Practum 213-1S	210g x 0.001g	4.75"	10 lb	7607	1,440.00
Practum 313-1S	310g x 0.001g	4.75"	10 lb	7608	1,555.00
Practum 612-1S	610g x 0.01g	7"	8 lb	7609	1,130.00
Practum 1102-1S	1100g x 0.01g	7"	8 lb	7610	1,250.00
Practum 2102-1S	2100g x 0.01g	7"	8 lb	7611	1,310.00
Practum 5101-1S	5100g x 0.1g	7"	8 lb	7612	1,335.00
Practum 5100-1S	5100g x 1.0g	7"	8 lb	7625	1,030.00



TE Precision balance

Weighing craftsmanship that is easy to afford. Left and right tare keys. Typical modes of use are counting of small parts, weighing in percent, net-total calculation, toggling between two weight units, weigh averaging. Battery operable units without 'S' suffix use (8) AA batteries. RS232 data interface. LCD Liquid Crystal Display. Includes AC adapter.

Part Number	Capacity	Pan	Weight	SKU	List
TE212	210 x 0.01g	4.6"dia	8 lb	4677	\$ 595.00

Options

YDP03-OCE Data printer with statistics & time/date	5 lb	3751	980.00
YCC01-USBM2 cable RS232 to USB	1 lb	3763	221.00



**TE212
Precision Balance**



M-Prove Precision balance

Very compact design. Can be stacked. The M-Class balances were developed especially for ambitious first time users in the laboratory and academic sector. Keys for I/O, ZERO, CAL, F, ENTER, PRINT. 9VDC battery (not included). 120VAC adapter, included.

Part Number	Capacity	Pan	Weight	SKU	List
AY123	120 x 0.001g	97mm dia	4.19 lb	7703	\$ 475.00



**AY123
Precision Balance**

Prices are subject to change without notice. Please call for current prices.

Other items are available from the manufacturers, please call for prices.

13-01 Pollitt Dr Ext
Fair Lawn NJ 07410
201-797-2718



www.totalcomp.com
sales@totalcomp.com
Fax 201-797-2287

setra



HI410S
Precision balance



SI2000S
Precision balance

HI & SI Precision balance

Award winning variable capacitance sensing technology. Large bright LED display. Rapid update rate for filling. Bidirectional RS232. Rugged die cast aluminum housing. Chemically resistant keypad. Stainless steel weighing pan. Standard RS232 interface. HI series has keys for CAL, MODE, PRINT, UNITS, TARE/POWER, %. Units are grams, ounces, carats, %, g per second, user defined unit. Fast or slow update rate. Print will transmit data instantaneously, continuously or at selected intervals. SI has keys for MODE, TARE/POWER. Dual range balances display the finest resolution whenever the balance is tared, regardless of how much weight is zeroed out. 120 VAC adapter, 11"L x 7"W x 3"H.

Part Number	Capacity	Pan	Weight	SKU	List
HI410S *	410g x 0.001g	4.75" dia	10 lb	6070	\$ 2,633.53
HI4100S	4,100g x 0.01g	6.25" dia	10 lb	6071	2,414.07
SI200S *	200g x 0.001g	4.75" dia	10 lb	6072	2,326.28
SI410D *	100g x 0.001g	4.75" dia	10 lb	6073	2,019.04
	410g x 0.01g				
SI410S *	410g x 0.001g	4.75" dia	10 lb	6074	2,414.07
SI2000S	2,000g x 0.01g	6.25" dia	10 lb	6075	2,019.04
SI4100D	1,000g x 0.01g	6.25" dia	10 lb	6076	2,019.04
	4,100g x 0.1g				
SI4100S	4,100g x 0.01g	6.25" dia	10 lb	6077	2,194.61
* Cylindrical draftshield included					
Options					
407914R	Draftshield, 3 way glass door for 4.75" dia pan		2 lb	6080	404.11
407902	CC Dustcover		1 lb	6082	36.74
Service Parts					
407712	120 VAC adapter		1 lb	6066	112.66
409748	Supercount AC adapter		1 lb	6083	112.66
404290-01R	load cell 1kg		5 lb	6062	1,464.59
404290-02R	load cell 2.5kg		5 lb	6041	1,464.59
404290-04R	load cell 12.5kg		5 lb	6042	1,464.59
404290-05R	load cell 25kg		5 lb	6043	1,464.59
404290-06R	load cell 34kg		5 lb	6088	1,464.59
404290-07R	load cell 50kg		5 lb	6044	1,464.59



A&D WEIGHING DIVISION

MX MF ML MS Moisture Analyzers

Fast and uniform heating with halogen lamp. Four measurement programs: Standard, Automatic, timer, Manjal. Memory function for test parameters and results. Up to 20 measurements conditions can be stored and recalled in MX-50. 10 can be stored in MF-50. Large, clear, easy to see VFD display. Plexiglass window for checking heating process. Conformity to GLP, GMP, GCP and ISO with date/time. ID, calibration data and check record outputs. Includes (20) sample pans, (2) pan handles, tweezers, spoon, test sample (30g of sodium tartrate dihydrate), CD-ROM (WinCT-Moisture for MX-50, WinCT for MF-50), RS232C cable for MX-50, display cover, dust cover, instruction manual, quick reference card, power cable, (2) fuses. 120 VAC, 50/60 Hz, 400 Watts, 5.4"W x 8.1"D x 4.4"H.

Part Number	Capacity	Percent	Pan	Weight	SKU	List
MX-50	51g x 0.001g	100 x 0.01%	2.16"dia	16 lb	4522	\$ 4,070.00
MF-50	51g x 0.002g	100 x 0.05%	2.16"dia	16 lb	4523	3,285.00
ML-50	51g x 0.005g	100 x 0.1%	2.16"dia	16 lb	4890	2,755.00
MS-70	71g x 0.001g	100 x 0.001%	2.16"dia	16 lb	4447	6,540.00

Service Parts

AX-31 Sample pans (washable, 100 ea)	1 lb	4524	115.00
AX-32 Glass fiber sheets (100 ea)	1 lb	4525	60.00
AX-33 Sodium tartrate dihydrate test samples (30g x 12 ea)	1 lb	4526	100.00
AX-34 Halogen lamp (replacement)	1 lb	4527	75.00
AX-35 Pan handles (2 ea)	1 lb	4528	30.00
AX-36 Tweezers (2 ea)	1 lb	4529	20.00
AX-37 Spoons (2 ea)	1 lb	4530	25.00
AX-38 Display covers (5 ea)	1 lb	4531	50.00
AX-39 Dust cover	1 lb	4532	20.00
AX-42 WinCT-Moisture (std for MX-50, option for MF-50)	1 lb	4533	280.00
AD-1700-20g Calibration Mass 20g	1 lb	4360	125.00
AX-43 Temperature Calibration (MX-50)	1 lb	4547	525.00
PZ:3844-3852 Transformer/power supply bd MX MF	1 lb	4548	232.00
PZ:3843-HITAR Heater relay bd MX MF	1 lb	4549	124.00



MF-50
Moisture Balance



MX-50
Moisture Balance

Prices are subject to change without notice. Please call for current prices.

Other items are available from the manufacturers, please call for prices.

13-01 Pollitt Dr Ext
Fair Lawn NJ 07410
201-797-2718

Totalcomp
Scales & Balances

www.totalcomp.com
sales@totalcomp.com
Fax 201-797-2287

Moisture



MB120
Moisture Balance

OHAUS®

MB Moisture Determination Balance

Automatic determination of moisture content. GLP compliant format when printed results are required. Fast halogen element provides uniform infrared heating up to 200 deg C. Heat from 50 deg C to 180 deg C in less than 1 minute. Display shows % moisture, % solids, weight, time, temperature and drying time. Program and recall up to 50 drying procedures. Once programmed, simply select and run test. Allows simple test editing to find best result. Auto shut off. Programming options are fast, standard, ramp or step. RS232 bidirectional interface is standard. 2 Year warranty. 120 VAC, 50/60 Hz, 7.5"W x 14"D x 6"H, 3.5" dia pan.

Part Number	Capacity	Percent	Pan	Weight	SKU	List
MB120	120g x 0.01g	100 x 0.01%	3.5"dia	19 lb	4678	\$ 6,468.00

Options

80850043 Security Device up to 8kg				1 lb	1632	305.00
CBM-910 Impact printer, 42 column				5 lb	7426	395.00
11113857 Temperature calibration kit				1 lb	3042	778.00
80500525 Cable to IBM 9 pin serial				1 lb	3047	254.00
80500571 Cable to SF42 Impact printer				1 lb	3048	254.00
80850080 WinWedge software				1 lb	2436	702.00

Service Parts

80850087 Pads, glass fiber, 200/box				1 lb	3043	137.00
80850086 Sample pans, 50/box				1 lb	3044	87.00
80850088 Reusable sample pans, pack of 3				1 lb	3045	266.00



MB200
Moisture Balance

OHAUS®

MB200 Moisture Determination Balance

Options and service parts only for MB200.

Part Number	Weight	SKU	List
Options			
80850000 Anti theft security device	1 lb	1295	\$ 118.00

Service Parts

80780012 Pan liners, pack of 100, 5"dia aluminum	1 lb	533	108.00
6081-B0 Pan liners, pack of 1,000, 5"dia aluminum	9 lb	577	256.00

OHAUS®

MB45 Service Parts Only

Service parts only for MB45

Part Number	Weight	SKU	List
80252851 Membrane switch	1 lb	3480	\$ 124.00



MB23 Moisture Analyzer Balance

Infrared heating. MB series combine high quality and durable construction into sleek, compact designs. One button setup. Large backlit LCD display. Manual, timed or auto shutoff. Standard RS232 port. Readabilities of 0.1%. 2 year warranty. 100 to 240 VAC, 50/60 Hz. 6.5"W x 11"D x 5"H.

Part Number	Capacity	Pan	Weight	SKU	List
MB23	110g x 0.01g	3.5" dia	9 lb	4028	\$ 3,802.00



MB23
Moisture Analyzer Balance



MB27 Moisture Analyzer Balance

Halogen heating. MB series combine high quality and durable construction into sleek, compact designs. One button setup. Large backlit LCD display. Manual, timed or auto shutoff. Standard RS232 port. Readabilities of 0.01%. 2 year warranty. 100 to 240 VAC, 50/60 Hz. 6.5"W x 11"D x 5"H.

Part Number	Capacity	Pan	Weight	SKU	List
MB27	90g x 0.001g	3.5" dia	9 lb	6491	\$ 3,802.00



MB27
Moisture Analyzer Balance



MB90 Moisture Analyzer Balance

Fast Halogen heating technology. Large touchscreen display. Icon driven menu navigation. Stainless steel drying pan. Four mechanical keys for fast one step operation, Tare, Start/Stop, Print, On/Off. Manual, timed or auto shutoff. Standard RS232 port. Readabilities of 0.01%. 2 year warranty. 100 to 240 VAC, 50/60 Hz. 6.5"W x 11"D x 5"H.

Part Number	Capacity	Pan	Weight	SKU	List
MB90	90g x 0.001g	3.5" dia	9 lb	4065	\$ 5,096.00



MB90
Moisture Analyzer Balance

Prices are subject to change without notice. Please call for current prices.

Other items are available from the manufacturers, please call for prices.



**MA35
Moisture Balance**

MA35 Moisture Balance

Quick and reliable analysis using thermogravimetric method. Fully Automatic infrared moisture analyzer, perfect for routine operation. Sartorius MA35 is a long-lasting, rugged built, impervious to vibration and dirt, reliable even in a harsh environment. Simple use, quick measurement results with heating elements generating 360 watts of power. Temp. settings 40-160 deg C. Measures display: % of moisture, % dry mass, % ATRO, g residue conformity to GLP, data interference RS232C-S, 7 data-bit ASCII multi language selection. Power consumption max. 400VA. Power 115VAC case dimensions 224"W x 366"D x 191"H mm.

Part Number	Capacity	Weight	SKU	List
MA35M-115US	350g x 0.01g	17 lb	4725	\$2,570.00
MA357-1US	70g x 0.001g	19 lb	4832	\$3,600.00



A&D WEIGHING DIVISION

EK-L Precision Bench Scale

Ideal for use when large capacity and high resolution are required at the same time. The EK-15KL has 0.1 g readability across its full 15 kg capacity. The EK-30KL has a smart range function. This is especially useful when the gross weight exceeds 3 kg yet 0.1 g readability is needed to measure net weight when using heavy tare containers. A single press of the re-zero key restores the 0.1 g precision range up to 3 kg.

Part Number	Capacity	Weight	SKU	List
EK-15KL	15,000g x 0.01g	12 lb	5539	\$ 980.00
EK-30KL	3,000g x 0.1g 30,000g x 1g	12 lb	5540	980.00
Service Parts				
07:4011266A adjustable foot		0.05 lb	2986	21.86



EK-L

Prices are subject to change without notice. Please call for current prices.

Other items are available from the manufacturers, please call for prices.

13-01 Pollitt Dr Ext
Fair Lawn NJ 07410
201-797-2718



www.totalcomp.com
sales@totalcomp.com
Fax 201-797-2287



A&D WEIGHING DIVISION

GP Industrial Balance

The resolution and functions of analytical balances with the capacity and ruggedness of industrial balances. Adjustable swing arm display. Weighing modes: gram, decimal ounce, decimal pound, carat, pennyweight, troy ounce, grain, momme. Percentage and counting modes. Internal calibration weight. RS232 output is standard. Stainless steel weighing pan. 120 VAC, 50/60 Hz, 15"W x 24"D x 6"H.



GP-12K
w/ column



GP-30KS
Industrial Balance
w/ remote indicator

Part Number	Capacity	Pan	Weight	SKU	List
Swing arm display column					
GP-12K	12,000g x 0.1g	13.5" x 15"	39 lb	5505	\$ 3,935.00
GP-20K	21,000g x 0.1g	13.5" x 15"	39 lb	5506	4,330.00
GP-32K	6,000g x 0.1g	13.5" x 15"	39 lb	5507	3,585.00
	31,000g x 1g				
GP-30K	31,000g x 0.1g	13.5" x 15"	39 lb	5508	5,145.00
GP-40K	41,000g x 0.5g	13.5" x 15"	39 lb	5509	4,780.00
GP-60K	61,000g x 1g	13.5" x 15"	39 lb	5510	5,875.00
GP-61K	61,000g x 0.1g	13.5" x 15"	39 lb	3372	6,740.00
GP-100K	100,000g x 1g	13.5" x 15"	42 lb	5511	6,185.00
GP-102K	61,000g x 1g	13.5" x 15"	42 lb	5512	5,620.00
	101,000g x 10g				
Remote Indicator					
GP-30KS	31,000g x 0.1g	13.5" x 15"	39 lb	5513	5,510.00
GP-32KS	6,000g x 0.1g	13.5" x 15"	39 lb	3373	3,995.00
	31,000g x 1g				
GP-60KS	61,000g x 1g	13.5" x 15"	39 lb	3375	6,135.00
GP-61KS	61,000g x 0.1g	13.5" x 15"	39 lb	3376	6,555.00
GP-100KS	100,000g x 1g	13.5" x 15"	42 lb	5514	6,670.00
Options					
GP-04 Comparator output w/buzzer			1 lb	5515	275.00
GP-06 Analog output			1 lb	5516	975.00
GP-07 Extension cable			1 lb	5517	360.00
GP-20 Underhook GP-12K thru 40K			1 lb	5518	215.00
GP-21 Underhook GP-60K thru 102K			1 lb	5519	215.00
GP-22 Printer support for AD-8121A			1 lb	5520	170.00
Service Parts					
04:B31752D pan for CP/HP			1 lb	5772	295.00
06:4010654 rubber pan support for GP			1 lb	5791	15.00
PZ:3634 display board for GP			1 lb	5595	313.00

Prices are subject to change without notice. Please call for current prices.

Other items are available from the manufacturers, please call for prices.



NV Navigator Industrial Balance

Two touchless sensors which free up your hands for handling samples and minimizing wear and tear on the keypad. 6 digit, 7 segment with white LED backlight or red LED. 4 mechanical keys, raised with tactile feedback. Weighing units for: gram, kilogram, pound, ounce (decimal or fractional), pound (decimal or fractional), ounce troy, grain, newton, carat, pennyweight, Hong Kong tael, Taiwan teal, Singapore teal, tical, tola. Application modes for: Weighing, Percent Weighing, Parts Counting, Check Weighing, Display Hold, Accumulate/Totalize. Over-accept-under LCD or LED annunciators. Front mounted level bubble with illumination. Adjustable leveling feet with skid resistant rubber pads. Full capacity by subtraction tare range. User selectable external span or linearity calibration, digital with external weight. 12VDC AC adapter included or (4) AA batteries (not included). 8.03"W x 8.34"D x 5.27"H.



**Navigator XL
Industrial Balance**

Part Number	Capacity	Pan	Weight	SKU	List
NV212	210g x 0.01g	4.42" dia	4 lb	7802	\$ 398.00
NV511	510g x 0.1g	7.48" x 5.43"	4 lb	7803	273.00

Options

80251930 RS232 Adapter	1 lb	7425	52.00
83032107 RS232 Interface w/ cable	2 lb	6162	220.00
83032108 USB Interface w/ cable	2 lb	6163	220.00

Prices are subject to change without notice. Please call for current prices.

Other items are available from the manufacturers, please call for prices.

13-01 Pollitt Dr Ext
Fair Lawn NJ 07410
201-797-2718



www.totalcomp.com
sales@totalcomp.com
Fax 201-797-2287

OHAUS®

NVT Navigator Industrial Balance



NVT1601
Industrial Balance

Front mounted level bubble with illumination, adjustable leveling feet with skid resistant rubber pads. User selectable external span or linearity calibration with external weight. 6 digit, 7 segment with white LED backlight or red LED. Over/accept/under LCD or LED annunciators. 4 mechanical keys, raised and with tactile feedback plus 2 touchless sensors. Weighing units: gram, kilogram, pound, ounce (decimal or fractional), pound:ounce (decimal or fractional), ounce troy, grain, newton, carat, pennyweight, Hong Kong tael, Taiwan tael, Singapore tael, tical, tola. Applications modes: weighing, percent weighing, parts counting, check weighing, display hold, accumulate/totalize. User enabled auto power off after 5 minutes of inactivity. (4) C batteries not included or internal rechargeable lead acid battery (optional). 12VDCAC adapter, 240V, 50-60Hz. 9.4"W x 9.8"D x 2.75H

Part Number	Capacity	Pan	Weight	SKU	List
NVT3201	3,200g x 0.2g	9" x 6.85"	7 lb	7669	538.00



EX Explorer Industrial Balance

Die cast metal base, stainless steel pan and thick metal housing. Explorer High Capacity is built to withstand daily wear and tear. 5.7" color VGA touch screen optimizes viewing and menu navigation. Two sensors on display offer hands free operation. The display can be separated from the base up to 1.5 meters in order to fit operational needs in almost any workspace. Weighing units: g, kg, ct, gn, lb, oz, ozt, N, dwt, hkt, sgt, twt, mom, tical, msg, tola, Custom Unit 1, Custom Unit 2, Custom Unit 3. Weighing applications: Weighing, Percent Weighing, Parts Counting, Check Weighing, Dynamic/Animal Weighing, Filling, Totalization, Formulation, Differential Determination, Peak Hold, Ingredient Costing, SQC. A 9 meter cable is also available when additional flexibility is needed. 2D Protection prevents shock and damage associated with movement and forces applied to the balance. Adjustable rolling feet provide assistance in easily moving the balance. IP54 protection guards balance and weighing cell from damage by dry particles, humidity and accidental spills/splashes (High Capacity models only). Rechargeable battery option provides 10 hours of operation away from a power source. Standard RS232, USB. 100-240 VAC. 17.4"W x 14.8"D x 4.72"H



Explorer Industrial Balance

Part Number	Capacity	Pan	Weight	SKU	List
EX12001	12,000g x 0.1g	15" x 12"	28 lb	7344	\$ 5,026.00
EX24001	24,000g x 0.1g	15" x 12"	28 lb	7345	6,122.00
EX35001	35,000g x 0.1g	15" x 12"	28 lb	7346	7,190.00

Prices are subject to change without notice. Please call for current prices.

Other items are available from the manufacturers, please call for prices.

13-01 Pollitt Dr Ext
Fair Lawn NJ 07410
201-797-2718



www.totalcomp.com
sales@totalcomp.com
Fax 201-797-2287



**Application Level 1
Industrial Scale**



**Application Level 3
Industrial Scale**



Flexible display

Signum Series Industrial Balance

Compact. Extremely rugged. Easy to operate. Perfectly adapts to any ambient conditions in an industrial environment. Space saving design. Choice of various resolutions. Washdown resistant and splashproof to IP65. Smart customization. Speed up technology. Custom tailored application package. Overload protection. Side impact protection. Flexible display mounting options.

Level 1: Weighing, (6) keys.

Level 3: Weighing, (17), keys, 0-9 numeric keypad, port for reference, counting, totalization, checkweighing, classification, product data memory, identifiers (4 x 40 characters), filling and counting to a target weight.

Part Number	Capacity	Pan	Weight	SKU	List
Application Level 1					
SIWADCP-V3	7kg x 0.1g	13.7" x 9.4"	30 lb	7498	\$ 2,245.00
SIWRDCP-V6	3kg x 0.1g	13.7" x 9.4"	30 lb	7502	1,712.00
SIWRDCP-V7	6kg x 0.2g	13.7" x 9.4"	30 lb	7503	1,722.00
Application Level 3					
SIWADCP-V4	7kg x 0.1g	13.7" x 9.4"	30 lb	7499	2,875.00
SIWADCP-V5	35kg x 0.5g	13.7" x 9.4"	30 lb	7500	2,875.00
SIWADCP-V6	65kg x 1.0g	13.7" x 9.4"	30 lb	7501	2,875.00
SIWRDCP-V8	15kg x 0.5g	13.7" x 9.4"	30 lb	7504	2,087.00
SIWRDCP-V9	35kg x 1.0g	13.7" x 9.4"	30 lb	7505	1,760.00
SIWRDCP-V10	60kg x 2.0g	13.7" x 9.4"	30 lb	7506	1,781.00



WLC Industrial balance

Stainless steel weighing platform. Backlit LCD display. Designed for fast and precise mass determination in laboratory and industrial conditions. WLC can be used in areas with no access to mains (230V), as their standard equipment they include internal rechargeable batteries. Applications for: Counting pieces, Checkweighing, Animal weighing, Percentage, Caps lock of max indication, Measurement in Newton. Loads are hung under the instrument, an alternative for weighing loads with non-standard dimensions and shapes. RS232 output. IP43. 230 VAC.

Part Number	Capacity	Pan	Weight	SKU	List
Fixed Display					
WLC6/F1/R	6kg x 0.1g	11" x 14"	18 lb	7623	\$ 599.00
WLC30/F1/R	30kg x 0.5g	11" x 14"	18 lb	7627	599.00
WLC60/C2/R	60kg x 1g	15.7" x 19.6"	40 lb	7629	916.00
Detachable Display					
WLC6/F1/K	6kg x 0.1g	11" x 14"	18 lb	7632	599.00
WLC30/F1/K	30kg x 0.5g	11" x 14"	18 lb	7636	599.00
WLC60/C2/K	60kg x 1g	15.7" x 19.6"	40 lb	7638	916.00



**WLC/R
industrial balance**



WLY Industrial balance

Simple operation and maximum automation of the weighing process. 5.7" color touch screen panel. Counting pieces, filling, animal weighing, check weighing, density determination, percentage, statistics, formulation. GLP procedures. Infrared proximity sensors. Detachable indicator. Data exchange through USB storage devices. Communication interfaces: Ethernet, (2) USB ports, RS232.

Part Number	Capacity	Pan	Weight	SKU	List
WLY2/D2	2 kg x 0.01g	7.7" dia	8 lb	7591	2,148.00
WLY10/D2	10 kg x 0.1g	7.7" dia	8 lb	7593	1,937.00
WLY20/D2	20 kg x 0.1g	7.7" dia	8 lb	7594	2,148.00



**WLY
Industrial balance**

Industrial

Prices are subject to change without notice. Please call for current prices.

Other items are available from the manufacturers, please call for prices.

13-01 Pollitt Dr Ext
Fair Lawn NJ 07410
201-797-2718

Totalcomp
Scales & Balances

www.totalcomp.com
sales@totalcomp.com
Fax 201-797-2287



**PGWe Series
Topload Balance**

PGWe Topload Balance

Delivering the ultimate in speed and accuracy, the PGWe sets a new industry benchmark for reliability, durability and ease of use. 17 weighing units, 7 weighing modes. Backlit LCD with multilingual display. Keys are: PRINT, CALIBRATE, MODE, UNIT. Weighing units are: gram, milligram, kilogram, carat, grain, newton, dram, pound, ounce, troy ounce, pennyweight, momme, tael (Taiwan, Hong Kong and Singapore), tola, tical and 1 custom unit. Applications for weighing, net/total, check weighing, percentage weighing, weight accumulation, averaging, parts counting, animal/dynamic weighing, density determination, below balance weighing. Capacity tracker, RS 232 bi-directional interface, second communication port. 120 VAC adapter for 15 VDC, 800 ma Three year ADAM warranty.

Part Number	Capacity	Pan	Weight	SKU	List
PGW3502e	3,500g x 0.01g	7.6" x 7.6"	11 lb	6963	\$ 1,075.00

Shimadzu

Service parts only for Shimadzu

Part Number	Weight	SKU	List
Service Parts BFL-321-51552-01, Small pan support	1 lb	82	\$ 21.50



A&D WEIGHING DIVISION

MC Analytical Balance

Precision balances with extended resolution. VFD display. Display weight results with an extra decimal place not normally found in balances of this capacity. Weighing units for: g, oz, lb, lb/oz, troy oz, ct, dwt, grain, momme. Applications include: Precious metal weighing, Fill ratio of gas cylinders, Electronic & semiconductor manufacturing, Moisture content of catalysts, Pharmaceutical manufacturing, Precision check-weighing with wider ranges, Discharge from feeders (loss in weight), Cutting dust (contaminants) left on mechanical parts, Particles trapped by particulate filters. Super hybrid sensor technology. Manage ASTM & OIML weights. Auto-centering pan options. Auto environmental adjustment. Counting, percentage, comparator modes. GLP/LIMS/ISO compliance. Underhook. Internal calibration standard. 5 year warranty.

Part Number	Capacity	Pan	Weight	SKU	List
MC-1000S	1,100g x 0.1mg	5.04" x 5.04"	5 lb	6318	\$ 7,275.00
MC-6100S	6,100g x 0.001g	6.49" x 6.49"	6 lb	6319	7,280.00
MC-10KS	10.1kg x 0.001g	10.6" x 8.26"	10 lb	6320	8,720.00
MC-30KS	31kg x 0.01g	10.6" x 8.26"	10 lb	6321	8,720.00
MC-100KS	101kg x 0.1g	15.1" x 13.5"	15 lb	6327	10,545.00

Options

AX-MC1000 Auto centering pan	1 lb	6693	1,320.00
AX-MC6100 Auto centering pan	1 lb	6694	1,320.00
AX-MC-10K/30K Auto centering pan	1 lb	6695	1,605.00
GX-15 Carrying case	1 lb	6696	615.00
AD-1684 Electrostatic Fieldmaster	1 lb	6697	1,730.00
AD-1688 Weighing data logger	1 lb	6698	360.00
AD-1689 Tweezers for calibration weight	1 lb	6699	220.00
KO:WW9-25 RS232C cable	1 lb	6700	55.00
AX-USB-2920-25P USB to 25 pin RS232	1 lb	6701	95.00
AX-USB-2920-9P USB to 9 pin RS232	0.42 lb	6744	65.00
GX-02* USB option w/ cable for MC-1000/6100	1 lb	7577	175.00
GX-04* Comparator Output, only for MC-1000/6100	1 lb	4693	910.00
GX-06* Analog output	1 lb	4694	990.00
GX-12 Animal weighing pan	1 lb	4697	210.00
GX-13* Density determination kit	1 lb	4698	720.00
AD-8922A Remote controller	1 lb	2234	750.00
GX-04K** Comparator output & RS232C	1 lb	6638	425.00
GX-06K** Analog voltage output/ 20ma interface	1 lb	6639	980.00
GX-07K Waterproof RS232C	1 lb	6640	360.00
AD-1682 External rechargeable battery pack	1 lb	1682	800.00
AD-1683 Static eliminator	4 lb	1248	1,405.00
SW:128 Foot switch	1 lb	4699	96.00

*GX-02, GX-04, GX-06, and the standard RS232C interface cannot be used at the same time.

**GX-04K, GX-06K, and the standard RS232C interface cannot be used at the same time.



MC-6100
Analytical Balance



MC-10K
Analytical Balance

Prices are subject to change without notice. Please call for current prices.

Other items are available from the manufacturers, please call for prices.

13-01 Pollitt Dr Ext
Fair Lawn NJ 07410
201-797-2718

Totalcomp
Scales & Balances

www.totalcomp.com
sales@totalcomp.com
Fax 201-797-2287



A&D WEIGHING DIVISION



BM-252
Analytical Balance

BM Series Analytical Balance

Built in Direct Current (DC) fanless ionizer. Clear, white backlit LCD. Interlockable slide doors. Large weighing chamber for improved usability. Built in environmental sensors. Weighing applications for: g, mg, oz, ozt, ct, mom, dwt, GN, tael, tola, PC (counting mode), percent mode. Density determination function. Data memory function can store up to 200 sets of weighing data. GLP/GMP/GCP/ISO compliant output. Motor driven internal calibration mass. Automatic response adjustment. RS-232C and Quick USB can be connected simultaneously to a balance. An external key plug for the optional foot switch is also provided. Overall dimensions 10"W x 18.3"D x 12.8"H.

Part Number	Capacity	Pan	Weight	SKU	List
BM-5	5.2g x 0.001mg	0.98" dia	22 lb	6450	\$ 17,475.00
BM-5D	2.1g x 0.001mg 5.2g x 0.01mg	0.98" dia	22 lb	6451	16,505.00
BM-20	22g x 0.001mg	0.98" dia	22 lb	6485	19,155.00
BM-22	5.1g x 0.001mg 22g x 0.01mg	0.98" dia	22 lb	6486	18,185.00
BM-252	250g x 0.01mg	0.98" dia	22 lb	6487	9,680.00
BM-200	200 x 0.1mg	0.98" dia	22 lb	6488	5,140.00
BM-300	320g x 0.1mg	0.98" dia	22 lb	6489	5,355.00
BM-500	520g x 0.1mg	0.98" dia	22 lb	6490	7,460.00



A&D WEIGHING DIVISION



HR-AZ
Analytical Balance

HR-AZ/HR-A Analytical Balance

Lean design for affordability. Clear, reverse backlit LCD. Large removable breeze break with antistatic coating. The 'Z' unit has internal clock and one touch internal calibration. Weighing units: g, mg, oz, oz-t, ct, momme, dwt, grain, tael, tola, pcs (counting mode), percent, DS (density mode). GLP/GMP/GCP/ISO compliant output. Adjustable response characteristics and hold function. Statistical calculation function. Density determination kit. Rechargeable battery unit. 120 VAC 7.8"W x 11.6"D x 12.4"H

Part Number	Capacity	Pan	Weight	SKU	List
HR-100A	102g x 0.1mg	3.54"	8 lb	7722	\$ 1,995.00
HR-150A	152g x 0.1mg	3.54"	8 lb	7723	2,155.00
HR-250A	252g x 0.1mg	3.54"	8 lb	7726	2,355.00
HR-100AZ	102g x 0.1mg	3.54"	8 lb	7727	2,485.00
HR-150AZ	152g x 0.1mg	3.54"	8 lb	7728	2,635.00
HR-250AZ	252g x 0.1mg	3.54"	8 lb	7729	2,795.00

Service Parts

00:C42767D front glass	1 lb	7089	62.00
06:4005645 leveling foot	0.03 lb	1228	10.00



HR-A
Analytical Balance

Prices are subject to change without notice. Please call for current prices.

Other items are available from the manufacturers, please call for prices.



A&D WEIGHING DIVISION

GH Phoenix Analytical

Automatic or manual full digital calibration. Weighing units: gram, milligram, decimal ounce, troy ounce, pennyweight, carat, momme, grain, tola, tael, percentage & counting. 10" tall weighing chamber. GLP/LIMS/ISO compliant. 5 year warranty. 120VAC 50/60 HZ, 8.54"W x 17.4"D x 12.24"H

Part Number	Capacity	Pan	Weight	SKU	List
GH-120	120g x 0.1 mg	3.6" dia	18 lb	5233	\$ 3,985.00
GH-200	210g x 0.1 mg	3.6" dia	18 lb	5234	4,515.00
GH-300	310g x 0.1 mg	3.6" dia	18 lb	5235	5,310.00
GH-202	210g x 0.1g / 42g x 0.01mg	3.6" dia	18 lb	5236	5,970.00
GH-252	250g x 0.1g / 100g x 0.01mg	3.6" dia	18 lb	5237	6,570.00

Options

AD-100-2 Anti-theft device	1 lb	1849	90.00
AD-1653 Density determination kit	1 lb	2997	660.00
AD-1682 Rechargeable battery pack	5 lb	1682	800.00
AD-8920 Universal remote display	3 lb	1160	315.00
AD-8922 Remote Controller	1 lb	2234	750.00
AD-1683 Static eliminator	4 lb	1248	1,405.00
SW: 128 Foot switch	1 lb	4699	96.00
TB: 636 AC adapter (120V)- standard with unit	1 lb	1304	45.00
TB: 123 AC adapter (220V)	1 lb	1542	53.00

Service Parts

PZ:4365 switch board	0.02 lb	1614	81.00
06:4005645 leveling foot	0.03 lb	1228	10.00



GH
Analytical Balance

Prices are subject to change without notice. Please call for current prices.

Other items are available from the manufacturers, please call for prices.

13-01 Pollitt Dr Ext
Fair Lawn NJ 07410
201-797-2718

 **Totalcomp**
Scales & Balances

www.totalcomp.com
sales@totalcomp.com
Fax 201-797-2287



A&D WEIGHING DIVISION



GR-202
Analytical Balance

GR Analytical Balance

High performance up to 0.01mg Semi-Micro weighing Automatic self calibration and ergonomic design. Weighing modes: gram, milligram, decimal ounce(av), troy ounce, pennyweight, carat, momme, grain, tola, tael, percentage & counting. Allows GLP or LIMS balance management by outputting the ID number and weight used to calibrate the balance, to A&D's AD-8121 printer or computer, indicating date time, balance ID number and calibration weight. 120 VAC 50/60 Hz, 9.8" x 12.99" x 12.87"H.

Part Number	Capacity	Pan	Weight	SKU	List
GR-120	120g x 0.1mg	85mm dia	14 lb	4010	\$ 3,430.00
GR-200	210g x 0.1mg	85mm dia	14 lb	4011	3,895.00
GR-202	210g x 0.1mg 42g x 0.01mg	85mm dia	14 lb	4012	5,515.00
GR-300	310g x 0.1mg	85mm dia	14 lb	3955	4,850.00

Options

AD-100-2 Anti-Theft Device	1 lb	1849	90.00
AD-1653 Density Determination Kit	1 lb	2997	660.00
AD-1682 Rechargeable Battery Pack	5 lb	1682	800.00
AD-8920 Universal Remote Display	3 lb	1160	315.00
AD-8922 Remote Controller	1 lb	2234	750.00
AD-1683 Static Eliminator	4 lb	1248	1,405.00
SW: 128 Foot Switch	1 lb	4699	96.00

Service Parts

TB:636 AC Adapter (120V)	1 lb	1304	45.00
TB:123 AC Adapter (220V)	1 lb	1542	53.00
PZ:3184 display board	1 lb	5472	82.00
PZ:3184-SW Key Switch Board	1 lb	5427	72.00
08: 3003743-3 keysheet GR-120	1 lb	5490	23.00
08: 3003743-4 keysheet GR-300	1 lb	5491	23.00
06:4005645 leveling foot	0.03 lb	1228	10.00

Prices are subject to change without notice. Please call for current prices.

Other items are available from the manufacturers, please call for prices.



A&D WEIGHING DIVISION

AD-1683 Static Eliminator

Compact, lightweight and does not require high voltage wiring which makes it easy to handle. DC type, this static eliminator has a remarkable ability for generating ions and can be used for the elimination of static charges from highly electrified weigh samples. Achieves static elimination with a high degree of efficiency regardless of the polarity or the potential of the charged object. A current limiting circuit is incorporated in the ion generating electrode to reduce the possibility of electric shock. Suited for static elimination in narrow and remote places because of its lengthy ion irradiation distance. The AD-1683 is a great compliment to our GH Semi micro balances. 240 VAC, 50/60 Hz.

Part Number	Weight	SKU	List
AD-1683	4 lb	1248	\$ 1,405.00



**AD-1683
Static Eliminator**

Prices are subject to change without notice. Please call for current prices.

Other items are available from the manufacturers, please call for prices.

13-01 Pollitt Dr Ext
Fair Lawn NJ 07410
201-797-2718



www.totalcomp.com
sales@totalcomp.com
Fax 201-797-2287



EX Explorer Semi Micro Balance

Sophisticated professional weighing. Autocal uses 2 internal weights for linear calibration. Color touchscreen display. Touchless Auto doors on AD models. Ionizer to eliminate static electricity. Includes a built in weigh below hook. Weighing functions for: Standard weighing, counting, percent weighing, checkweighing, Dynamic weighing, filling, totalization, formulation, differential weighing, peak hold, density determination, pipette adjustment. Keys for: Touchscreen. Units are g, mg, kg, ct, oz, ozt, lb, dwt, N, mom, tical, msg, tola, baht, tael(3), ozt and custom unit(3). 15.5"L x 9.1"W x 13.8"H. 120 VAC.



Explorer
Semi Micro Balance

Part Number	Capacity	Pan	Weight	SKU	List
EX125D	52gx0.01mg/120gx0.1mg	90mm dia	25 lb	2563	\$ 7,259.00
EX125	120gx0.01mg	90mm dia	25 lb	2564	9,049.00
EX225D	120gx0.01mg/220gx0.1mg	90mm dia	25 lb	2565	9,258.00
EX225D/AD	120gx0.01mg/220gx0.1mg	90mm dia	27 lb	2566	9,565.00
EX225/AD	220gx0.01mg	90mm dia	27 lb	2567	11,746.00

Options

30252145 Pipette adjustment kit		4 lb	2568	1,899.00
30093334 Dust cover		1 lb	2569	61.00
30064203 SF40A Dot Matrix printer, includes RS232 cable		2 lb	1754	1,303.00
80251932 Roll paper		1 lb	7427	28.00
80251933 Ink ribbon		1 lb	7428	75.00
80252571 RS232 Cable & adapter, Disc/Pion/MB		1 lb	7430	193.00
80253384 Density determination kit		3 lb	2794	1,022.00



AX Adventurer Analytical Balance

Color Touchscreen with wide viewing angle. Ingenious draftshield opens wide on both sides. Automatic internal calibration system that calibrates the balance daily. Real time clock with GLP/GMP data. Application modes for Weighing, Dynamic Weighing, Display Hold, Parts Counting, Density Determination, Totalization/Statistic, Percent Weighing, Check Weighing and Formulation. Weighing units for: gram, milligram, mesgal, Newton, ounce, pennyweight, baht, carat, grain, pound, Hong Kong tael, Singapore tael, Taiwan tael, tical, tola, ounce troy, 1 custom unit. RS232, (2)USB ports. 100-240 VAC adapter. 9.05"W x 13.93"D x 13.39"H. 2 year warranty.

Part Number	Capacity	Pan	Weight	SKU	List
Analytical, AutoCal.					
AX124	120g x 0.0001g	90mm dia	18 lb	8223	\$ 3,936.00
AX224	220g x 0.0001g	90mm dia	18 lb	8224	4,345.00
AX324	320g x 0.0001g	90mm dia	18 lb	8225	4,748.00
Analytical, External Calibration					
AX124/E	120g x 0.0001g	90mm dia	18 lb	3961	3,249.00
AX224/E	220g x 0.0001g	90mm dia	18 lb	3962	3,566.00
Options					
30064203 SF40A Dot Matrix printer, includes RS232 cable			2 lb	1754	1,303.00
80500525 Cable to IBM 9 pin serial			1 lb	3047	254.00
83021085 USB interface w/cable			1 lb	8234	254.00
Service Parts					
30111779 main board AX			1 lb	6527	563.00
30111768 keypad AX			1 lb	6528	51.00



AX1502
Analytical Balance

Prices are subject to change without notice. Please call for current prices.

Other items are available from the manufacturers, please call for prices.

OHAUS®

EX Explorer Analytical Balance

Intelligent performance. Intuitive software. Ingenious draftshield. Practical touchless sensors. 5.7" full color VGA graphic display. Touch screen. Weighing applications for: Weighing, Percent Weighing, Check Weighing, Dynamic/Animal Weighing, Filling, Totalization, Formulation, Differential Weighing, Density Determination, Peak Hold, Ingredient Costing, Pipette Adjustment, SQC. Weighing units for: gram, milligram, kilogram, carat, ounce, ounce troy, pound, pennyweight, grain, newton, momme, mesghal, Hong Kong tael, Singapore tael, Taiwan tael, tical, tola, baht, 3 custom units. RS232, USB communication. 100-240 VAC adapter. 9.1"W x 15.5"D x 13.8"H. 2 year warranty.



EX220
Analytical Balance



Part Number	Capacity	Pan	Weight	SKU	List
EX124	120g x 0.1mg	3.5" dia	22 lb	7770	\$ 5,390.00
EX224	220g x 0.1mg	3.5" dia	22 lb	7771	5,989.00
EX324	320g x 0.1mg	3.5" dia	22 lb	7772	7,033.00

Automatic Doors

EX124/AD	120g x 0.1 mg	3.5" dia	22 lb	7710	5,580.00
EX224/AD	220g x 0.1 mg	3.5" dia	22 lb	7711	6,191.00
EX324/AD	320g x 0.1 mg	3.5" dia	22 lb	7712	7,271.00

NTEP Legal for Trade 12-012 I/II Canada AM-5847

EX224N	220g x 0.1mg	3.5" dia	22 lb	7613	6,584.00
EX324N	320g x 0.1mg	3.5" dia	22 lb	7614	7,708.00

Automatic Doors

EX224N/AD	120g x 0.1 mg	3.5" dia	22 lb	7714	7,380.00
EX324N/AD	120g x 0.1 mg	3.5" dia	22 lb	7715	8,050.00



PR Analytical and Precision Balance

Economical balances for routine weighing applications. Model numbers with 'N' are NTEP Certified. ABS housing, stainless steel pan, glass draftshield on milligram models only, weigh below hook, security lock interface. Backlit liquid crystal display LCD. Weighing applications for: Basic Weighing, Parts Counting, Percent Weighing. Weighing units for: gram, milligram, kilogram, ounce, pound, carat, Troy ounce, grain. RS232, USB communication. 100-240 VAC adapter (included), 20"W x 15"D x 21"H w/draftshield, 21.5"W x 15"D x 11.5"H, . 2 year warranty.
NTEP Legal for Trade

Part Number	Capacity	Pan	Weight	SKU	List
PR64/E	62g x 0.1mg	4.72" dia	15.4 lb	5341	\$ 1,767.00
PR124 *	120g x 0.1mg	4.72" dia	15.4 lb	5342	2,296.00
PR124/E	120g x 0.1mg	4.72" dia	15.4 lb	5343	2,037.00
PR224 *	220g x 0.1mg	4.72" dia	15.4 lb	5344	2,545.00
PR224/E	220g x 0.1mg	4.72" dia	15.4 lb	5345	2,263.00
PR223/E	220g x 1mg	4.72" dia	15.4 lb	5346	1,120.00
PR523/E	520g x 1mg	4.72" dia	15.4 lb	5347	1,337.00
PR1602/E	1,600g x 0.01g	7.09" dia	11.0 lb	5348	1,034.00
PR2202/E	2,200g x 0.01g	7.09" dia	11.0 lb	5349	1,178.00
PR4202/E	4,200g x 0.01g	7.09" dia	11.0 lb	5350	1,408.00
PR2201/E	2,200g x 0.1g	7.09" dia	11.0 lb	5351	919.00
PR4201/E	4,200g x 0.1g	7.09" dia	11.0 lb	5352	1,063.00

NTEP Legal for Trade 18-110

PR323N/E	320g x 0.01g	4.72" dia	15.4 lb	4244	1,368.00
PR523N/E	520g x 0.01g	4.72" dia	15.4 lb	4245	1,743.00
PP523N *	520g x 0.01g	4.72" dia	15.4 lb	4246	2,020.00
PR322N/E	320g x 0.01g	4.72" dia	15.4 lb	4247	1,380.00
PR522N/E	520g x 0.01g	4.72" dia	15.4 lb	4248	1,749.00
PR822N/E	820g x 0.1g	7.09" dia	11.0 lb	4249	1,126.00
PR2202N/E	2,200g x 0.1g	7.09" dia	11.0 lb	4250	1,253.00
PR5202N/E	5,200g x 0.1g	7.09" dia	11.0 lb	4251	1,749.00
PR2201N/E	2,200g x 0.1g	7.09" dia	11.0 lb	4252	1,287.00
PR5201N/E	5,200g x 0.1g	7.09" dia	11.0 lb	4253	1,328.00
PR6201N/E	6,200g x 1g	7.09" dia	11.0 lb	4254	1,403.00

* Internal calibration



PR323N/E
Analytical Balance



PR822N/E
Analytical Balance



Prices are subject to change without notice. Please call for current prices.

Other items are available from the manufacturers, please call for prices.

13-01 Pollitt Dr Ext
Fair Lawn NJ 07410
201-797-2718

Totalcomp
Scales & Balances

www.totalcomp.com
sales@totalcomp.com
Fax 201-797-2287

OHAUS®

PX Pioneer Analytical Balance

Metal base, plastic top housing, removable stainless steel pan, Glass draftshield, integrated weigh-below hook, security bracket, calibration lock and in-use cover. Backlit liquid crystal display LCD. Weighing applications for: Basic Weighing, Parts Counting, Percent Weighing, Animal Weighing, Density Determination. Weighing units for: gram, milligram, kilogram, ounce, pound, carat, pennyweight, Troy ounce, grain, newton, momme, mesghal, Hong Kong tael, Singapore tael, Taiwan tael, tical, tola, baht, 1 custom unit. RS232, USB communication. 100-240 VAC adapter (included), 21.7"W x 15.2"D x 11.5"H. 2 year warranty.



PX124
Analytical Balance

Part Number	Capacity	Pan	Weight	SKU	List
PX84/E	82g x 0.1mg	3.54" dia	15.4 lb	3663	\$ 2,182.00
PX124/E	120g x 0.1mg	3.54" dia	15.4 lb	3664	2,517.00
PX224/E	220g x 0.1mg	3.54" dia	15.4 lb	3665	2,794.00

Internal Calibration

PX84	82g x 0.1 mg	3.54" dia	15.4 lb	3657	2,545.00
PX124	120g x 0.1 mg	3.54" dia	15.4 lb	3658	2,915.00
PX224	220g x 0.1 mg	3.54" dia	15.4 lb	3659	3,204.00

OHAUS®

PX Pioneer Semi Micro Balance

Metal base, plastic top housing, removable stainless steel pan, Glass draftshield, integrated weigh-below hook, security bracket, calibration lock and in-use cover. Backlit liquid crystal display LCD. Weighing applications for: Basic Weighing, Parts Counting, Percent Weighing, Animal Weighing, Density Determination. Weighing units for: gram, milligram, kilogram, ounce, pound, carat, pennyweight, Troy ounce, grain, newton, momme, mesghal, Hong Kong tael, Singapore tael, Taiwan tael, tical, tola, baht, 1 custom unit. RS232, USB communication. 100-240 VAC adapter (included), 21.7"W x 15.2"D x 11.5"H. 2 year warranty.



PX85
Semi-Micro Balance

Part Number	Capacity	Pan	Weight	SKU	List
PX85	82g x 0.01mg	3.15" dia	11 lb	3655	\$ 5,380.00
PX225D	82g x 0.01mg 220g x 0.1mg	3.15" dia	11 lb	3656	6,232.00



Secura Analytical Balance

Easy, reliable weighing in regulated areas. The new operating concept of Secura® will noticeably ease your daily workload during weighing and, its APC function – Advanced Pharma Compliance – will relieve you from tedious and time-consuming documentation and monitoring tasks. Touch screen with Sartorius graphical user interface optimized for users in pharmaceutical laboratories always correctly leveled with Sartorius LevelControl. Special lab applications such as Mixing, Components, Statistics and Conversion; plus standard lab applications such as Weighing, Density, Percentage, Checkweighing, Peak Hold, Counting and Unstable Conditions. Regulatory Compliance with expert support. Intelligent, optoelectronic level sensor with alarm function and interactive user guidance for reliable and safe leveling.

Part Number	Capacity	Pan	Weight	SKU	List
SECURA224-1S	220 g x 0.1 mg	3.5"	12 lb	7150	\$ 4,930.00
SECURA124-1S	120 g x 0.1 mg	3.5"	12 lb	7154	4,450.00
SECURA513-1S	510 g x 1 mg	3.5"	12 lb	7155	3,710.00
SECURA313-1S	310 g x 1 mg	3.5"	12 lb	7156	2,960.00
SECURA213-1S	210 g x 1 mg	3.5"	12 lb	7157	2,720.00
SECURA5102-1S	5100g x 10 mg	7"	12 lb	7158	3,840.00
SECURA3102-1S	3100 g x 10 mg	7"	12 lb	7159	3,340.00
SECURA2102-1S	2100 g x 10 mg	7"	12 lb	7160	3,080.00
SECURA1102-1S	1100 g x 10 mg	7"	12 lb	7161	2,590.00

Options

YDP-20 OCE Printer			3 lb	7286	1,190.00
YDP-40 Standard printer			3 lb	7287	950.00
YRB11Z Battery kit			2 lb	7288	610.00
YCC04-D09 USB Data cable			1 lb	7289	57.00
YCC03-D09 USB /RS232 cable			1 lb	7290	57.00

Service Parts

69SE0056 lateral slide, right			0.73 lb	7284	565.00
69SE0057 lateral slide, left			0.73 lb	7285	565.00



SECURA124



SECURA2103



SECURA2102



SECURA1102-1S
w/ Printer

Prices are subject to change without notice. Please call for current prices.

Other items are available from the manufacturers, please call for prices.

13-01 Pollitt Dr Ext
Fair Lawn NJ 07410
201-797-2718

Totalcomp
Scales & Balances

www.totalcomp.com
sales@totalcomp.com
Fax 201-797-2287



Quintix Analytical Balance

Sartorius teamed up with lab users to develop the user interface of the new Quintix. Lab users number one priority was to ensure easy, intuitive operation without having to read the manual first. Chemically resistant finish of the housing for the easiest cleaning ever. Quintix comes standard with convenient, built in applications for: Mixing, Components, Statistics, Checkweighing, Density, Weighing, Conversion, Peak Hold, Unstable Conditions, Percentages, Counting. Analytical draft shield chamber with doors that glide open smoothly for fatigue free weighing. All panels can be individually cleaned or exchanged. IsoCAL, fully automatic, temperature and time controlled internal calibration and adjustment. Mini USB port.



Quintix-513-1S
Analytical



Quintix-3102-1S
Analytical

Part Number	Capacity	Pan	Weight	SKU	List
Quintix-124-1S	120g x 0.1mg	3.5"	12 lb	7477	\$ 3,550.00
Quintix-224-1S	220g x 0.1mg	3.5"	12 lb	7478	4,020.00
Quintix-213-1S	210g x 0.001g	4.75"	11 lb	7479	2,100.00
Quintix-313-1S	310g x 0.001g	4.75"	11 lb	7480	2,245.00
Quintix-513-1S	510g x 0.001g	4.75"	11 lb	7481	3,040.00
Quintix-612-1S	610g x 0.01g	7"	9 lb	7482	1,775.00
Quintix-1102-1S	1100g x 0.01g	7"	9 lb	7483	2,010.00
Quintix-2102-1S	2100g x 0.01g	7"	9 lb	7484	2,245.00
Quintix-3102-1S	3100g x 0.01g	7"	9 lb	7485	2,485.00
Quintix-5102-1S	5100g x 0.01g	7"	9 lb	7486	3,080.00
Quintix-5101-1S	5100g x 0.1g	7"	9 lb	7487	1,775.00
Quintix-5100-1S	5100g x 1g	7"	9 lb	7488	1,420.00

Options

YDP20-OCE Statistical data printer w time & date	3 lb	7286	1,190.00
6906918 Ink ribbon for YDP20-OCE	1 lb	7507	37.00
YDP40 Standard thermal printer	3 lb	7287	950.00
YRB112 Rechargeable battery	2 lb	7288	610.00
YDK03 Specific gravity kit	2 lb	7509	900.00
YDK04 Specific gravity kit for Top Loader	2 lb	7511	790.00
YCC03-D09 USB to RS232 cable	1 lb	7290	57.00
YCC04-D09 USB data cable	1 lb	7289	57.00

Service Parts

6960SE01 Analytical base cover	1 lb	7633	45.00
6960SE02 Top Load base cover	1 lb	7634	43.00
6960SE03 Dust cover for Analytical chamber	1 lb	7635	33.00
YEPS01-PS4 adapter 100-240vac to 12vdc	0.39 lb	3055	75.00



TJA Analytical Balance

Electronic analytical balance ideal for laboratory weighing. Easy to see in low light conditions 9 digit LCD display with backlight. Stainless steel weighing pan 3.15" dia. Sensitivity and speed are separately adjustable in 4 steps from low to high. Continuous output RS232 via 9 pin connector for remote display or computer input. Below balance weighing for specific gravity determination. Weighing functions for: Standard weighing and counting. Keys for: OFF, PRINT, O/T, CAL, ON. Units are g, mg, ct, oz. Glass breeze break with top and side doors allow for quick placement of item to be weighed. CAL button and 200g calibration weight allow for easy recalibration of balance. Rear bubble level and two adjustable feet allow for quick leveling. 13.4"L x 8.5"W x 13.8"H. 120 VAC.

Part Number	Capacity	Pan	Weight	SKU	List
TJA-203	200g x 0.001g	3.15" dia	17 lb	5966	\$ 679.00



TJA-203
Analytical Balance

Mechanical Portion



Benchmark



Heirloom Scale

Durable. Rugged accuracy. Powder coated finishes in a variety of designer colors. Made of cast iron with case hardened steel pivots and bearings, and a polished brass 1lb beam in 1/4 ounce increments. The scales come in black, white, blue, pink, red, green, yellow, silver and copper vein.

Benchmark: This indispensable kitchen tool features (2) 6" cold rolled steel plates, a polished brass 1 lb beam in 1/4 ounce increments and (3) free-weights (2) 1lb and (1) 2 lb.

Part Number	Capacity	Weight	SKU	List
1704B Benchmark	5 lb x 1 oz	16 lb	7597	\$ 394.16



TB Portion Control Baker's Dough Scale

Rugged, accurate, even-balance scale. Specially designed seamless white plastic commodity scoop. Includes counterweight and 9" dia plates. Finished in durable USDA approved white oven baked enamel.

Models 1051 & 1052 are stainless steel construction for the base, plates and poise weights. Beam is chrome plated. Mechanism is epoxy coated.

Part Number	Capacity	Weight	SKU	List
1001TB w/scoop	16 lb x 1/4 oz	38 lb	5981	\$ 987.00
1001TBNS w/o scoop	16 lb x 1/4 oz	38 lb	5982	957.00
1001TBKG w/scoop	8kg x 5g	38 lb	5983	1,049.00
1002TB w/scoop	8 lb x 1/4 oz	30 lb	5984	865.00
1002TBNS w/o scoop	8 lb x 1/4 oz	30 lb	5985	803.00
1002TBKG w/scoop	5kg x 5g	30 lb	5986	865.00

Stainless Steel

1051TBS w/scoop	16 lb x 1/4 oz	38 lb	5987	1,242.00
1052TBS w/scoop	8 lb x 1/4 oz	30 lb	5988	1,178.00

Options

1WP1-1 flat weight	1 lb	2 lb	5989	48.00
1WP2-1 flat weight	2 lb	3 lb	5990	78.00
1WP4-1 flat weight	4 lb	5 lb	5991	90.00
1WP8-1 flat weight	8 lb	9 lb	5992	119.00

6100-0001 Scoop white plastic w/spout 10"x2.5"H	4 lb	5994	88.25
6100-0002 Scoop white plastic w/spout 21"x12"x5.75"H	4 lb	5995	127.75
6100-0003 Bowl SS w/o spout 6.25"x2.25"H	3 lb	5996	89.25



**1002TB
Portion Control Scale**

Prices are subject to change without notice. Please call for current prices.

Other items are available from the manufacturers, please call for prices.



P Spring Dial Scale

The P Spring Dial Scale has an air damping dashpot that eliminates the bounce and provides a quick and accurate measurement everytime. Heavy gauge stainless steel housing. Heavy duty top loading mechanical spring scale. Large stainless steel platter. Dual easy to read dial in lb's and oz's, kg's and grams. Angled dial design for easy reading. Fine zero adjustment to ensure accuracy. Perfect for portioning and receiving.

Part Number	Capacity	Platform	Weight	SKU	List
P-5 Spring scale	5 lb x 1/2 oz	8" x 8"	8 lb	7601	\$ 63.47
P-10 Spring scale	10 lb x 1 oz	8" x 8"	8 lb	7602	63.47



P-2
Portion Mechanical Scale

Prices are subject to change without notice. Please call for current prices.

Other items are available from the manufacturers, please call for prices.

13-01 Pollitt Dr Ext
Fair Lawn NJ 07410
201-797-2718



www.totalcomp.com
sales@totalcomp.com
Fax 201-797-2287

Mechanical Portion



FS
Spring Dial Scale



LCD
Spring Dial Scale



HCD
Spring Dial Scale

FS Spring Dial Scale

Heavy duty Industrial scales with high precision temperature compensated springs and reinforced dual spring level mechanism. Double beveled base plate and heavy duty sub assembly combine to give you durability you can count on. Lb/Kg dial face for dual reading is signified by DR at the end of the model number.

Part Number	Platform	Capacity	Weight	SKU	List
FS Series 6" dial face w/SS platform 5-1/2"W x 7-3/8"D x 7-3/4"H					
FS3214-DR	5.75" x 5.75"	32 oz x 1/4 oz	4 lb	3837	\$ 87.00
FS0512-DR	5.75" x 5.75"	5 lb x 1/2 oz	4 lb	3838	97.00

FS Options

Rotating dial (Tare feature)			1 lb	3839	4.41
------------------------------	--	--	------	------	------

LCD Series 8" dial face w/SS platform 6-3/4"W x 9-3/4"D x 10-3/4"H

LCD3218-DR	9" x 9"	32 oz x 1/8 oz	9 lb	3841	135.00
------------	---------	----------------	------	------	--------

Option for LCD 3218 only

Rotating dial OVER/UNDER			1 lb	3858	25.00
--------------------------	--	--	------	------	-------

LCD0512-DR	9" x 9"	5 lb x 1/2 oz	9 lb	3842	130.00
LCD1001-DR	9" x 9"	10 lb x 1 oz	9 lb	3843	130.00
LCD2001-DR	9" x 9"	20 lb x 1 oz	10 lb	3844	130.00

LCD10K20 *	9" x 9"	10kg x 20g	10 lb	3845	135.00
LCD2501 *	9" x 9"	25 lb x 1 oz	10 lb	3846	135.00

* Not available as dual reading

LCD2502-DR	9" x 9"	25 lb x 2 oz	10 lb	3847	135.00
LCD4002-DR	9" x 9"	40 lb x 2 oz	10 lb	3848	141.00
LCD5002-DR	9" x 9"	50 lb x 2 oz	12 lb	3849	147.00

LCD7004-DR	10" x 10"	70 lb x 4 oz	13 lb	3850	194.00
------------	-----------	--------------	-------	------	--------

w/Chrome platform

LCD Options

Air dash pot (quick stop)			1 lb	3851	70.00
Stainless steel construction			1 lb	3852	85.00
Produce pan 10" dia stainless steel			1 lb	3853	96.00

HCD Series 10" dial face w/chrome platform 10-1/2"W x 14"D x 12-1/2"H

HCD7004-DR	13" x 13"	70 lb x 4 oz	24 lb	3855	295.00
HCD10004-DR	13" x 13"	100 lb x 4 oz	27 lb	3856	301.00
HCD20008 -DR	13" x 13"	200 lb x 8 oz	30 lb	3857	370.00

Prices are subject to change without notice. Please call for current prices.

Other items are available from the manufacturers, please call for prices.



Triple Beam Balance

Triple Beam 700 and 800 Series Balances. Tiered notched beams. Choice of weighing platforms, scoop, animal container or pans. Magnetic damping. Optional tare beam. Equipped for specific gravity weighings. 5 Year warranty

Part Number	Capacity	Platform	Weight	SKU	List
710-00	610g x 0.1g	SS Pan, 6" dia	7 lb	1523	\$ 372.00
710-T0	610g x 0.1g	SS Pan, tare	7 lb	1528	453.00
720-00	610g x 0.1g	Poly scoop	7 lb	1524	435.00
720-S0	610g x 0.1g	SS scoop	7 lb	1525	505.00
730-00	610g x 0.1g	Animal container	9 lb	1526	546.00
750-S0	610g x 0.1g	SS Plate, 6" dia	8lb	1521	205.00
760-00	610g x 0.1g	SS Plate, tare	8 lb	1527	383.00

Options

With counterweight

80780015	Stainless Steel Scoop 12" x 6" x 2-34"	2 lb	2023	172.00
	footed and counterweight			
80780016	Polypropylene Maxi-Scoop 10" dia x 1-12"	3 lb	2024	59.00

Without counterweight

80250400	Stainless Steel Scoop 12" x 6" x 2-3/4"	2 lb	2025	98.00
	footed, tare 190g			
80250954	Stainless Steel Scoop 17.2" x 11" x 3.4"	6 lb	5274	109.00
	footed, large			



710-00 SS pan w/optional attachment weights



720-00 SS Scoop



730-00 Animal Container



750-S0 SS plate



Triple Beam Junior

All the benefits of a Triple Beam, just for younger students. Notched and tiered beams. Magnetic damping. Zero adjust compensator. Metal base and beam, stainless steel pan. 5 Year warranty

Part Number	Capacity	Platform	Weight	SKU	List
TJ611	610g x 0.1g	SS Pan, 5.9" dia	6 lb	1612	\$ 199.00



TJ611 Triple Beam Junior

Prices are subject to change without notice. Please call for current prices.

Other items are available from the manufacturers, please call for prices.

13-01 Pollitt Dr Ext
Fair Lawn NJ 07410
201-797-2718

Totalcomp
Scales & Balances

www.totalcomp.com
sales@totalcomp.com
Fax 201-797-2287



1119-DO
Solution Balance

OHAUS®

Heavy Duty Solution Balance

Rugged and durable with magnetic dampening to provide quick, trouble free operation. Strongly built to resist corrosion and shrug off harsh environments it reads with a feather touch down to 1 g over the whole weighing range of 20 kg. It has a large, unobstructed **stainless steel** platform and a lockable tare for containers up to 2270 g. Covered self aligning bearings. Readings up to 1100 g are taken from two sliding weight beams and a set of slotted weights, which are stored in the base, extend the capacity to 20 kg. 5 year warranty.

Part Number	Capacity	Pan	Weight	SKU	List
1119-DO	20 kg x 1 g	11" dia	44 lb	1395	\$ 2,670.00



2400-11
Field Test Scale

OHAUS®

Field Test Scale

The heavy duty Multi purpose field scale is for use in laboratory, production facilities or field testing locations. The beam reads 1 lb by 0.01 lb divisions or 500 g by 5 g divisions. The numbers and graduations are in black on a white background for maximum legibility. The scale has a sliding poise designed to eliminate reading errors. A set of slotted weights is supplied with the scale and they store in the cast metal base. For ease in moving the scale, a carrying handle is an integral part of the base. 5 year warranty. 22-1/4" x 9-3/4" x 10-1/8"H.

Part Number	Capacity	Pan	Weight	SKU	List
2400-11	16 kg x 5 g	9-3/4" dia	23 lb	1312	\$ 1,974.00
2400-12	36 lb x 0.01 lb	9-3/4" dia	23 lb	1396	2,043.00



311 Cent-O-Gram® Balance
310 Dial-O-Gram® Balance

These balances provide 0.01 g sensitivity and come with all the built-in extras that are expected from Ohaus. The Dial-O-Gram® has the fastest results which are read on the precision engraved dial. Poises are windowed for easy reading. Built in specific gravity platform. Four notched and tiered beams on 311 Model. 10 gram vernier dial on 310 Model. Rugged, durable construction. 5 Year warranty.

Part Number	Capacity	Weight	SKU	List
Dial-O-Gram				
310-00	310g x 0.01g	6 lb	1530	\$ 538.00
	Dial and vernier 10g x 0.01g			
	Front beam 100g x 10g			
	Rear beam 200g x 100g			
Cent-O-Gram				
311-00	311g x 0.01g	6 lb	1531	445.00
	Front beam 1g x 0.01g			
	Second beam 10g x 1g			
	Third beam 100 x 10g			
	Rear beam 200 x 100g			



311-00
Cent-O-Gram
Balance



Triple Pro Balance

Accurate, dependable and truly best in class. Triple Pro offers the convenience of a toploading balance while allowing hands-on experience through manipulation of the poises. Easy grip carrying handle is perfectly balanced for effortless movement. Convenient storage compartment for included attachment weight set. Two security features included to prevent theft, a security loop and Kensington lock (cables sold separately). Includes included weight set and rod & clamp assembly for specific gravity determinations. 10 Year limited warranty

Part Number	Capacity	Platform	Weight	SKU	List
TP2611	2,610 x 0.1g	5.8" dia	9 lb	1536	\$ 294.00



TP2611
w/optional attachment weights



1600 Dial-O-Gram® Balance

Direct reading vernier dial. Tare poise slides for coarse tare, rotates for fine adjustments. Maximum capacity of 2610 g with optional accessory weights. 5 Year warranty

Part Number	Capacity	Tare	Platf/9rm	Weight	SKU	List
1610-00	610g x 0.1g	225 g	SS Pan, 6" dia	8 lb	1543	\$ 551.00
1650-00	610g x 0.1g	-----	SS Plate, 6" dia	8 lb	1541	478.00
1650-W0	2,610g x 0.1g	-----	SS Plate w/att wts	11 lb	1537	551.00

Options

80780017 Vinyl cover for Triple Beam	1 lb	96	45.00
80780108 Attachment weights, metric, 2.5 kg set	2 lb	877	96.00
701-00 Attachment weight, 500 g	1 lb	1532	16.00

The Attachment weights allow full utilization of the Triple Beam's capacity (2610g) by suspending weights from pivots on beam end. Requires (2)1,000g and (1)500g weights. Conveniently store in base of balance.



1650-00 SS Plate



Tare Feature

Prices are subject to change without notice. Please call for current prices.

Other items are available from the manufacturers, please call for prices.



1550-SD
Harvard Trip Balance

OHAUS®

Harvard Trip Balance

Beam and dial models available. Easy, reliable operation. Two pan balances of this type are commonly used for comparative weighing - to determine the difference in mass between two objects rather than the absolute value. The built in sliding masses (up to 10 or 210g) are usually suitable for this purpose, but weighings up to 2kg can be achieved by using a suitable set of calibrated masses. Magnetic damping. 0.1g sensitivity. 5 Year warranty

Part Number	Capacity	Beam/platform	Weight	SKU	List
1450-SD	2,000g x 0.1g	Single beam/Plate	7 lb	1825	\$ 497.00
1550-SD	2,000g x 0.1g	Double beam/Plate	8 lb	1828	531.00
1560-SD	2,000g x 0.1g	Dbl bm/Plate w/Tare	10 lb	1829	555.00

Options

80850321 Analytical scoop 1.25" x 2" (3.8 x 5.1cm) w/counterweight	1 lb	822	43.00
80850322 Analytical scoop 2.25" x 3" (5.7 x 7.6cm) w/counterweight	1 lb	823	43.00
Scoop is used on one pan and counterweight on the other.			
80850262 Vinyl dust cover for Harvard Trip balance	1 lb	628	48.00



HJ2001
Harvard Junior

OHAUS®

Harvard Junior

Two pan balance designed to teach comparative weighing. The easy grip carrying handle will help students and teacher alike securely move the balances around the classroom. The balances can be stacked to minimize the amount of storage space needed, and the lock feature protects the balance from damage when in storage. An eight piece weight set and bowls that fit on the weighing pans are included with every Harvard Junior. Steel pointer, ABS base, pans and bowls, metal beam. Manual damping device, spring loaded zero adjust compensator. Includes teacher developed activity guide.

Part Number	Capacity	Pan	Weight	SKU	List
HJ2001	2,000g x 0.5g	6"dia pan	7 lb	1827	\$ 171.00



School Balance

The young scientist's first balance. Large, washable pans provide optimal space for samples to be weighed. An 18 piece weight set (10)1g, (4)5g, (2)10g, (2)25g, color coded stackable plastic mass set included. Front and rear pointers allow students to view results from both sides of the balance. Plastic pointer. ABS base, beam and pans. Zero adjust compensator.

Part Number	Capacity	Pan	Weight	SKU	List
SB1200	2,000g x 0.5g	5.5"x5.5"	7 lb	1822	\$ 89.00



SB1200
School balance



Primer Balance

An activity guide with 16 exercises is included with every Primer balance. The easy to slide zero adjustment weight makes ensuring the balance is ready for weighing very simple. Front and rear pointers allow students to view results from both sides of the balance. Plastic pointer. ABS base, beam and pans. Large, washable weighing pans, dual pointers, An 18 piece weight set (10)1g, (4)5g, (2)10g, (2)25g, color coded stackable plastic mass set included.

Part Number	Capacity	Pan	Weight	SKU	List
80410-00	2,000g x 1g	4"x4"	2 lb	1830	\$ 64.00



90410-00
Primer balance

Prices are subject to change without notice. Please call for current prices.

Other items are available from the manufacturers, please call for prices.

13-01 Pollitt Dr Ext
Fair Lawn NJ 07410
201-797-2718



www.totalcomp.com
sales@totalcomp.com
Fax 201-797-2287

OHAUS®

Pull type spring scales

Pull type spring scales feature an internal spring mechanism and offer a versatile and inexpensive way to display measurements in grams, ounces, pounds and Newtons. Demonstration spring scales offer a large faceplate for easy viewing and are ideal for all basic weighing applications. ABS housing with metal face plate, pointer, spring and hook. Large bright colored face, easy to read graduations on a frosted aluminum background.



8001-MA
Pull type spring scales

Part Number	Capacity	Capacity	Weight	SKU	List
8001-MA	9 oz x 0.25 oz	250g x 10g	0.4 lb	7880	\$ 34.00
8002-MA	19 oz x 0.5 oz	500g x 20g	0.4 lb	7881	34.00
8004-MA	72 oz x 2 oz	2,000g x 50g	0.4 lb	7882	34.00
8001-MN	250g x 10g	2.5N x 0.1N	0.4 lb	7883	31.00
8002-MN	500g x 20g	5N x 0.2N	0.4 lb	7884	31.00
8003-MN	1,000g x 25g	10N x 0.25N	0.4 lb	7885	31.00
8004-MN	2,000g x 50g	20N x 0.5N	0.4 lb	7886	31.00
8008-MN	5,000g x 100g	50N x 1N	0.4 lb	7887	31.00
8261-MO	100g x 1g		0.4 lb	7888	37.00
8262-MO	200g x 2g		0.4 lb	7889	37.00
8263-MO	500g x 5g		0.4 lb	7890	37.00
8264-MO	1,000g x 10g		0.4 lb	7891	37.00
8265-MO	2,000g x 20g		0.4 lb	7892	37.00
8001-PN	0.56 lb x 0.02 lb	2.5N x 0.1N	0.4 lb	7893	37.00
8002-PN	1.12 lb x 0.04 lb	5N x 0.2N	0.4 lb	7894	37.00
8003-PN	2.25 lb x 0.05 lb	10N x 0.25N	0.4 lb	7895	37.00
8004-PN	4.5 lb x 0.125 lb	20N x 0.5N	0.4 lb	7896	37.00
8008-PN	11.25 lb x 0.25 lb	50N x 1N	0.4 lb	7897	37.00

OHAUS®

Dial type spring scales

Dial type spring scales offer a versatile and inexpensive weight determination in classrooms, laboratories, field studies and much more. Measurements in grams, ounces, pounds and Newtons. Demonstration spring scales offer a large faceplate for easy viewing and are ideal for all basic weighing applications. ABS housing with metal face plate, pointer, spring and hook. Large bright colored dial face, easy to read graduations on a frosted aluminum background.



8011-MA
Dial type spring scales

Part Number	Capacity	Capacity	Weight	SKU	List
8011-MA	9 oz x 0.125 oz	250g x 2g	0.4 lb	3013	\$ 51.00
8012-MA	18 oz x 0.25 oz	500g x 5g	0.4 lb	3014	51.00
8014-MA	2,000g x 20g	72oz x 0.5oz	0.4 lb	3015	51.00
8011-MN	250g x 2g	2.5N x 0.02N	0.4 lb	3016	51.00
8012-MN	500g x 5g	5N x 0.05N	0.4 lb	3017	51.00
8014-MN	2,000g x 20g	20N x 0.2N	0.4 lb	3018	51.00
8013-MN	1,000g x 10g	10N x 0.1N	0.4 lb	3019	51.00
8016-00	20N x 1/2N		0.4 lb	3020	97.00
8015-00	22hg x 1/2hg		0.4 lb	3021	97.00
8018-50	50N x 2N		0.4 lb	3022	107.00

Prices are subject to change without notice. Please call for current prices.

Other items are available from the manufacturers, please call for prices.



Reloading scale

Equipped with cast metal beams designed with wided spaced deep notches to prevent accidental poise movement. Self aligning agate bearings with steel beam pivots and stainless steel fine poises guarantee sensitivity to 0.1 grain. Removable pan with gold colored scoop with handle and spout. Pan supports cradle the pan so that it doesn't tip off when weighing cases, loaded cartridges, arrows etc. Ounce to grain conversion labels for quick reference. Die cast base with large leveling feet for extra stability and durable stainless steel poises. Mechanical design allows for use on the bench or at the practice range. Battery or AC power are not needed. Balance beams with magnetic dampening system to speed reloading.



5-0-2
Reloading scale

Part Number	Capacity	Scoop	Weight	SKU	List
5-0-2	505 grains x 0.1 grains	2"dia"	1.1 lb	1694	\$ 104.00
5-0-5	511 grains x 0.1 grains	2"dia"	1.1 lb	1695	145.00

Prices are subject to change without notice. Please call for current prices.

Other items are available from the manufacturers, please call for prices.

13-01 Pollitt Dr Ext
Fair Lawn NJ 07410
201-797-2718



www.totalcomp.com
sales@totalcomp.com
Fax 201-797-2287



854F100P
Beam Scale
mechanical portable



Mechanical Portable Beam Scale

Portable, durable accurate trouble free performance. Rust proof die cast beam is calibrated 100 lb x 1/2 lb on both front and back. Counterpoise weights are stored on a handy hanger. Easy to read lockable poise. Simplified lever system of fabricated steel for longer life and accuracy. Platform size 19"W x 28"D. Overall size 24"W x 35"D x 45"H. FOB Webb City, MO.

NTEP Legal for Trade 88-106/107

Part Number	Capacity	Weight	SKU	List
854F100P portable	1,000 lb x 1/2 lb	132 lb	4037	\$ 1,170.00



Mechanical Portable Beam Scale

A Fairbanks classic. Rugged and economical. Large platform. Sturdy cast iron base, lever system, platform and wheels. Large easy-to-read graduations on a chrome plated beam with a brass insert. Open face poise with pointer clearly shows the exact weight. A set screw holds the poise firmly in place when set. Dimensions 21"W x 36"D x 42.75"H. FOB Meridian, MS
 Canadian AM-4657
 NTEP Legal for Trade 88-266

Part Number	Capacity	Platform	Weight	SKU	List
1124 beam scale	1,000 x 0.5 lb	24" x 17"	185 lb	6065	\$ 1,144.00

Service Parts

95843 beam assy US standard for 1124			4 lb	6110	156.00
71596 set of counterpoise weights lbs for 1124			11 lb	6111	147.54
58935 cup hanger counterpoise for 1124			2 lb	6178	60.78



**1124
 Beam Scale
 Mechanical Portable**

Prices are subject to change without notice. Please call for current prices.

Other items are available from the manufacturers, please call for prices.

13-01 Pollitt Dr Ext
 Fair Lawn NJ 07410
 201-797-2718



www.totalcomp.com
 sales@totalcomp.com
 Fax 201-797-2287



TSCP-431
White plastic scoop



ST-64P
Sample pan, plastic, triangular



Aluminum scoop, large



TSCP-431-SS Scoop
Footed, large
Stainless steel



TSCP-431-SS Scoop
Large
Stainless steel

Scoops

For use with any balance or scale.

Part Number	Size	Weight	SKU	List
Plastic				
TSCP-431 scoop, anti static white plastic, FDA approved	21.5"x11.5"x5.5" w/6" dia foot	2 lb	2379	\$ 49.00
ST-64P Sample pan, anti static plastic, triangular	11"x10.5"x2.5"	2 lb	6109	20.40
Aluminum				
Aluminum scoop, medium	17" x 12" x 5"	2 lb	4220	177.00
Aluminum scoop, large	20.5" x 14" x 6"	3 lb	4221	185.00
Stainless steel				
TSCP-431-SSF footed scoop, large	12" x 23" x 5.5"	6 lb	6670	150.00
TSCP-441-SS scoop, large	12" x 22" x 5.5"	5 lb	6671	166.66



Scoops

For use with any balance.

Part Number	Size	Weight	SKU	List
80250048	Black aluminum scoop	4" x 3.5"	1 lb	1139 \$ 51.00
80850364	Aluminum scoop	2" x 1.5"	1 lb	1140 33.00
30020842	Gold scoop	3" x 2.25"	1 lb	1141 46.00
80250400	Stainless Steel Scoop footed, tare 190g	12" x 6" x 2-3/4"	2 lb	2025 98.00
80250954	Stainless Steel Scoop footed, large	17.2" x 11" x 3.4"	6 lb	5274 109.00



80250954 Stainless Steel Scoop

Weighing Dishes

These plastic anti-static weighing dishes are produced from a special grade of polystyrene and will resist diluted acids, aqueous solutions, alcohols and bases. They are safe, contaminant-free, biologically inert, economical containers which specifically made for many applications such as weighing, dispersing or storing. They can be used as quick freeze trays for sample material, discard trays, for broken ampules, or mixing trays for small batches. They have a smooth surface providing accurate pour-outs with minimal sample loss. Non-reactive with most substances and suitable for weighing static affected materials. Will withstand temperatures up to 80°C

Hexagonal

Globe Scientific's hexagonal plastic weighing dishes are available in 4 different sizes. The molded hexagonal design provides greater balance protection and safety. They are ideal for handling solids or liquids during weighing. They can be easily bent into pouring spouts to provide pour-outs with minimal sample loss.

Part Number	Volume	Dimensions	Weight	SKU	List
3615	20 mL	38 mm	1 lb	2547	\$ 35.50
3616	50 mL	64 mm	1 lb	2548	47.40
3617	200 mL	102 mm	1 lb	2549	84.30
3618	350 mL	127 mm	1 lb	2550	158.20



Hexagonal

Square

Globe Scientific's square weighing dishes are available in 3 different sizes. They have sloping sides, rounded corners and flat bottoms to ensure perfect stability on counters.

Part Number	Volume	Dimensions	Weight	SKU	List
3620	20 mL	41mm x 8mm H	1 lb	2551	23.80
3621	100 mL	89mm x 25mm H	1 lb	2552	48.10
3622	330 mL	140mm x 25mm H	1 lb	2553	123.00



Square

Pour boat

Globe Scientific's pour boats are available in 3 sizes. They are specifically made to facilitate dispensing of powdered and liquid materials. Smooth, uniform and economical, the molded material used is thicker than conventional weighing dishes.

Part Number	Volume	Dimensions	Weight	SKU	List
3623	2 mL	54 x 44 x 8mm	1 lb	2554	19.80
3624	140 mL	130 x 93 x 25mm	1 lb	2555	49.10
3625	270 mL	191 x 125 x 25mm	1 lb	2556	122.80



Pour-boat

Prices are subject to change without notice. Please call for current prices.

Other items are available from the manufacturers, please call for prices.

13-01 Pollitt Dr Ext
Fair Lawn NJ 07410
201-797-2718

Totalcomp
Scales & Balances

www.totalcomp.com
sales@totalcomp.com
Fax 201-797-2287

Clear Flexible Covers

Inuse covers for use with a variety of popular scales and balances. These covers protect from dripping paint and dyes, dust and dirt or any dripping liquid. They are easily replaceable when they have accumulated an excess of the contaminated product. The covers are made of a semi rigid clear PVC or PETG, yet they are soft enough to allow the easy use of the front panel keys on the scale or balance.

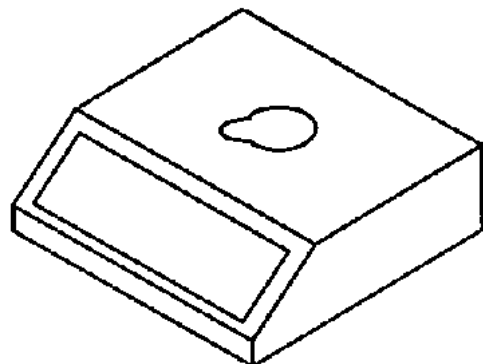

TFC-EK12KA A&D
Flexible covers

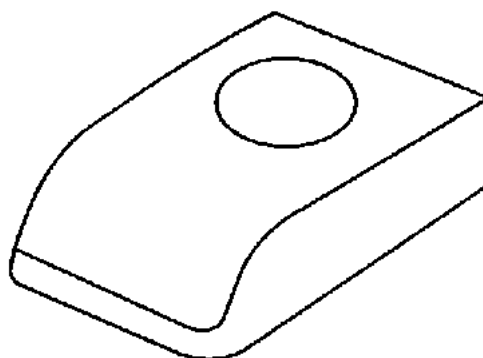

TFC-V/G Acculab
Flexible covers

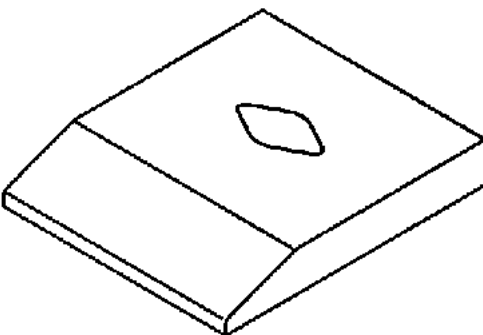

TFC-XL/XE/XS Denver
Flexible covers

Part Number	Weight	SKU	List
A&D			
TFC-EK12KA	1 lb	5569	\$ 36.00
TFC-EK120/1200A	1 lb	5570	36.00
TFC-EK6000H	1 lb	5571	36.00
TFC-EK/EWG series	1 lb	5572	36.00
TFC-EP series	1 lb	5573	36.00
TFC-FY series	1 lb	5575	36.00
TFC-GX200/400/600	1 lb	5576	36.00
TFC-GX2000/4000/6100	1 lb	5577	36.00
TFC-HF200/400	1 lb	5578	36.00
TFC-HF1200/4000	1 lb	5579	36.00
TFC-HF6000/8000	1 lb	5580	36.00
TFC-HP series	1 lb	5581	36.00
TFC-HX6000	1 lb	5582	36.00
Denver Instruments			
TFC-TR series	1 lb	3367	36.00
Mettler/Toledo			
TFC-AB54/AB104/AB204	1 lb	5588	36.00
TFC-AT series	1 lb	5590	36.00
TFC-BB round pan	1 lb	5591	36.00
TFC-BB square pan	1 lb	5592	36.00
TFC-PB153-303	1 lb	5593	36.00
TFC-PB602S-8001S	1 lb	5589	36.00
TFC-PC/AC	1 lb	5597	36.00
TFC-PE round pan	1 lb	5598	36.00
TFC-PE square pan	1 lb	5599	36.00
TFC-PE/PM large	1 lb	5600	64.00
TFC-PG-S 0.01&0.001	1 lb	5601	36.00
TFC-PG-S 0.1 - 1g	1 lb	5602	36.00
TFC-PG/SR display	1 lb	5603	36.00
TFC-PG/SR main body	1 lb	5604	36.00
TFC-PL-S	1 lb	5596	36.00
TFC-PM/PJ round pan	1 lb	5605	36.00
TFC-PM/PJ square pan	1 lb	5606	36.00
TFC-PR/PG main body	1 lb	5607	36.00
TFC-SB 8000-16000	1 lb	5608	64.00
TFC-SB 24000-32000	1 lb	5609	64.00
TFC-SR/SG display 1	1 lb	5610	36.00
TFC-SR/SG display 2	1 lb	5611	36.00
12102970 AP/PL	1 lb	5500	98.90
12102980 PL-S	1 lb	5501	163.00

Prices are subject to change without notice. Please call for current prices.

Other items are available from the manufacturers, please call for prices.



Clear Flexible Covers

Continued.

Part Number	Weight	SKU	List
Ohaus			
TFC-Adventurer	1 lb	5612	\$ 36.00
TFC-B small	1 lb	5613	36.00
TFC-CT series	1 lb	5615	36.00
TFC-Explorer/Voyager top loader	1 lb	5616	36.00
TFC-Explorer/Voyager analytical	1 lb	5617	36.00
TFC-GT/E round pan	1 lb	5618	36.00
TFC-GT/E square pan	1 lb	5585	36.00
TFC-Navigator	1 lb	5619	36.00
TFC-SC Scout	1 lb	5620	36.00
TFC-TM Pro Scout	1 lb	5586	36.00
TFC-TS/TP series	1 lb	5621	36.00
Precisa			
TFC-Precisa low profile	1 lb	5622	36.00
TFC-Precisa old type (A)	1 lb	5623	36.00
Sartorius			
TFC-1200	1 lb	5624	36.00
TFC-1400	1 lb	5625	36.00
TFC-1500/E	1 lb	5626	36.00
TFC-BA round pan	1 lb	5627	36.00
TFC-BA square pan	1 lb	5628	36.00
TFC-BL round pan	1 lb	5276	36.00
TFC-BL square pan	1 lb	5277	36.00
TFC-BP round pan, small	1 lb	5629	36.00
TFC-BP square pan, small	1 lb	5630	36.00
TFC-BP square pan, large	1 lb	5631	36.00
TFC-CP series triangular pan	1 lb	5632	36.00
TFC-CP series square pan	1 lb	5633	36.00
TFC-CP series analytical	1 lb	5634	36.00
TFC-EA/EB series	1 lb	5635	36.00
TFC-Element Series	1 lb	5278	36.00
TFC-L2200 round pan	1 lb	5636	36.00
TFC-L2200 square pan	1 lb	5637	36.00
TFC-L610	1 lb	5638	36.00
TFC-PNA series	1 lb	5639	36.00
TFC-PT	1 lb	5640	36.00
TFC-Scaletec round pan	1 lb	5641	36.00
TFC-Scaletec square pan	1 lb	5642	36.00
TFC-U/B/LC	1 lb	5643	36.00

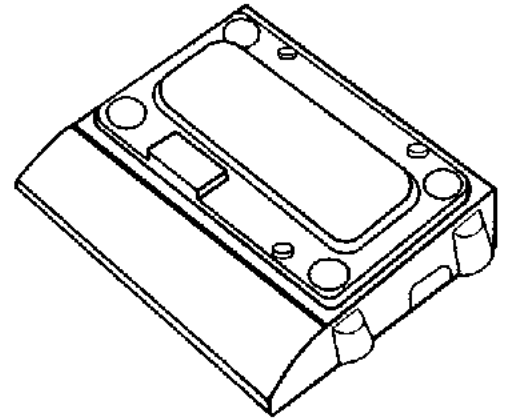

TFC-SB 8000-16000 Mettler
Flexible covers

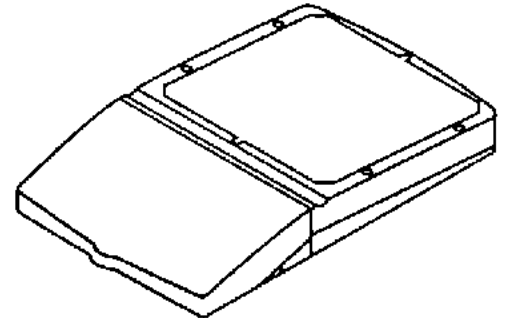

TFC-Explorer Ohaus
Flexible covers

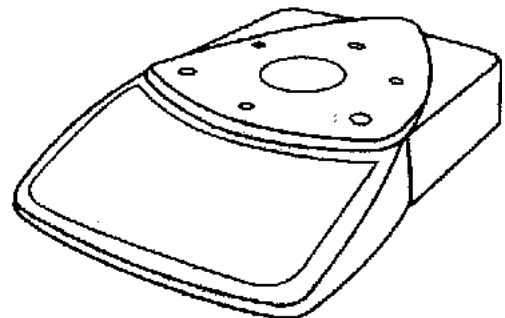

TFC-CP triangular Sartorius
Flexible covers

Prices are subject to change without notice. Please call for current prices.

Other items are available from the manufacturers, please call for prices.

MARK-10



Series 5
Digital Force Gauge

M5 Digital force gauge

Designed for tension and compression force testing. Reversible housing allows the gauge to be handheld or mounted to a test stand. Large, backlit graphics LCD display. 5 selectable units of measure: lbF, ozF, gF, kgF, N, kN, mN (depending on model). Keys are: ENTER, ON, UNITS/DIRECTION, DATA/DELETE, ZERO, MENU/ESCAPE, MODE. Data can be transferred to a PC or other data collector via USB, RS232, Mitutoyo (Digimatic), or analog outputs. High speed 7,000 Hz peak sampling rate. 1,000 point data memory with statistics and outputs. Live load bar with set point markers. Programmable set points, with alarms and outputs. Peak readings and set points always displayed. Averaging mode calculates average readings over time. External trigger mode for switch contact testing or remotely stopping display update. Configurable audio alarms and key tones. Password protection, configurable for individual keys and calibration. Included items: Carrying case with chisel, cone, V-groove, hook, flat, extension rod, universal voltage AC adapter, battery, quick start guide, USB cable, resource CD and NIST traceable certificate of calibration with data.

Part Number	Capacity	Weight	SKU	List
M5-012	0.12 lbF	1 lb	7641	\$ 1,765.00
M5-025	0.25 lbF	1 lb	7642	1,765.00
M5-05	0.5 lbF	1 lb	7643	1,410.00
M5-2	2 lbF	1 lb	7644	1,250.00
M5-5	5 lbF	1 lb	7645	1,250.00
M5-10	10 lbF	1 lb	7646	1,250.00
M5-20	20 lbF	1 lb	7647	1,250.00
M5-50	50 lbF	1 lb	7648	1,250.00
M5-100	100 lbF	1 lb	7649	1,250.00
M5-200	200 lbF	1.2 lb	7650	1,410.00
M5-300	300 lbF	1.2 lb	7349	1,410.00
M5-500	500 lbF	1.2 lb	7651	1,410.00
M5-750	750 lbF	1.8 lb	7350	1,700.00
M5-1000	1,000 lbF	1.8 lb	7351	1,700.00
M5-1500	1,500 lbF	1.8 lb	7352	1,700.00
M5-2000	2,000 lbF	1.8 lb	7353	1,700.00
M5-2-COF	2,000 lbF	1.8 lb	7354	1,475.00
COF-K1	Kit w/G1086 coef of friction feature	1.8 lb	7355	2,900.00

MARK-10

M7 Professional force gauge

High speed data capture. Foot switch. User defined unit. Keys for: ZERO, UNITS, MENU, DATA, MODE. 5,000 point memory and statistics. Break detection. USB, RS232. Mitutoyo and analog outputs. Averaging, set points with outputs, external trigger, extension rod chisel, cone, v-groove, flat, hook. AC adapter/charger. Carrying case. NIST certificate. 3 year warranty.

Part Number	Capacity	Weight	SKU	List
M7-012	0.12 lbF	1 lb	8108	\$ 2,425.00
M7-025	0.25 lbF	1 lb	8109	2,425.00
M7-05	0.5 lbF	1 lb	8110	2,100.00
M7-2	2 lbF	1 lb	8111	1,900.00
M7-5	5 lbF	1 lb	8112	1,900.00
M7-10	10 lbF	1 lb	8113	1,900.00
M7-20	20 lbF	1 lb	8114	1,900.00
M7-50	50 lbF	1 lb	8115	1,900.00
M7-100	100 lbF	1 lb	8116	1,900.00
M7-200	200 lbF	1 lb	8117	2,100.00
M7-500	500 lbF	1 lb	8118	2,100.00



M7 Professional Force Gauge

MARK-10

M4 Performance force gauge

Live load bar graph with with set point markers. Large backlit graphic display. Keys for: ZERO, UNITS, MENU, DATA, MODE. 3,000 Hz sampling rate. 50 point data memory with statistics and outputs. MESUR Lite Data collection software. Configurable audio alarms and key tones. USB, RS232, Mitutoyo. Extension rods, chisel, cone, v-groove, flat, hook, AC adapter/charger. Carrying case NIST certificate.



M4
Performance force gauge

Part Number	Capacity	Weight	SKU	List
M4-012	0.12 lbF	1 lb	8119	\$ 1,500.00
M4-025	0.25 lbF	1 lb	8120	1,500.00
M4-05	0.5 lbF	1 lb	8121	1,125.00
M4-2	2 lbF	1 lb	8122	945.00
M4-5	5 lbF	1 lb	8123	945.00
M4-10	10 lbF	1 lb	8124	945.00
M4-20	20 lbF	1 lb	8125	945.00
M4-50	50 lbF	1 lb	8126	945.00
M4-100	100 lbF	1 lb	8127	945.00
M4-200	200 lbF	1 lb	8128	1,125.00
M4-500	500 lbF	1 lb	8129	1,125.00

MARK-10

M3 Digital force gauge

Ultra compact size. Ergonomic, reversible aluminum housing allows for hand held use or test stand mounting for more sophisticated testing requirements. Large backlit graphic display. 4 selectable units of measure: lbf, gF, kgF, N (depending on model). Display indicators for: Set Points, Pass/Fail indicators, Current Reading, Battery Indicator, Tension/Compression indicator, Peak Readings, Measurement Mode, Units of Measure, Analog Load Bar w/ Set Point Markers. High speed 2,000 Hz sampling rate. USB data output. Configurable audio alarms and key tones. MESUR Lite data collection software included. Included items are: Carrying case with chisel, cone, V-groove, hook, flat, extension rod, universal voltage AC adapter, battery, quick start guide, USB cable, resource CD (USB driver, MESUR Lite software, MESUR gauge DEMO software, and user's guide), and NIST-traceable certificate of calibration (certificate with data is available for an additional charge). AC or rechargeable battery. Multi-step low battery indicator is displayed, gauge shuts off automatically when power is too low.



M3
Digital force gauge

Part Number	Capacity	Weight	SKU	List
M3-012	0.12 x 0.0001 lbF	1 lb	6680	\$ 1,285.00
M3-025	0.25 x 0.0002 lbF	1 lb	6681	1,285.00
M3-05	0.05 x 0.0005 lbF	1 lb	6682	895.00
M3-2	2 x 0.002 lbF	1 lb	6683	725.00
M3-5	5 x 0.005 lbF	1 lb	6684	725.00
M3-10	10 x 0.01 lbF	1 lb	6685	725.00
M3-20	20 x 0.02 lbF	1 lb	6686	725.00
M3-50	50 x 0.05 lbF	1 lb	6687	725.00
M3-100	100 x 0.1 lbF	1 lb	6688	725.00
M3-200	200 x 0.2 lbF	1 lb	6689	895.00
M3-500	500 x 0.5 lbF	1 lb	6690	895.00

MARK-10

M2 Economical force gauge

Reversible housing for alternate load cell orientation. A backlit graphic LCD displays the current, peak tension, or peak compression reading. Keys for: Menu, Peak, Zero. Peak tension and compression readings are reliably captured via the gauges' ±0.5% accuracy and 500 Hz sampling rate. Powered by 9V battery or available AC adapter. Series 2 gauges are directly compatible with Mark-10 test stands and grips.

Part Number	Capacity	Weight	SKU	List
M2-2	2 lbF	1 lb	8130	\$ 490.00
M2-5	5 lbF	1 lb	8131	490.00
M2-10	10 lbF	1 lb	8132	490.00
M2-20	20 lbF	1 lb	8133	490.00
M2-50	50 lbF	1 lb	8134	490.00
M2-100	100 lbF	1 lb	8135	490.00
M2-200	200 lbF	1 lb	8136	660.00
M2-500	500 lbF	1 lb	8137	660.00

Options

12-1049 Carrying Case		1 lb	8138	45.00
CERT NIST traceable certificate of calibration w/ data		1 lb	5971	90.00
23-1031-2 Attachment kit for M2-2 - M2-100		1 lb	8140	100.00
23-1031-3 Attachment kit for M2-200 - M2-500		1 lb	8141	120.00



Series 2 Economical Force Gauge

MARK-10

BG Digital force gauge

Reversible aluminum housing for hand held use or stand mounting. Programmable analog and digital filters. Compatible with all Mark 10 test stands and grips. Keys are: POWER, UNITS, ZERO, DATA, MODE, CLEAR. Units: lb, kg(g). 4-1/2 digit 0.3" LCD. 62 readings per second. GCL Gauge Control Language for full control of all functions. Measures tensile and compressive forces. Permanent configuration memory. Automatic peak memory, push button calibration. RS232 Mitutoyo and analog outputs, programmable auto shut off. Battery or AC operation. Includes cushioned carrying case with an AC adapter, user's manual and NIST certificate with a set of accessories: chisel, cone, V groove, hook, flat, extension.

Part Number	Capacity	Weight	SKU	List
BG2	2 x 0.001 lb	9 lb	5763	\$ 395.00
BG10	10 x 0.005 lb	9 lb	5765	395.00



BG Digital Force Gauge

Prices are subject to change without notice. Please call for current prices.

Other items are available from the manufacturers, please call for prices.

13-01 Pollitt Dr Ext
Fair Lawn NJ 07410
201-797-2718

Totalcomp
Scales & Balances

www.totalcomp.com
sales@totalcomp.com
Fax 201-797-2287



TT03
Torque gauge



TT03C
Cap torque gauge



WT3-201 manual
wire crimp pull tester



WT3-201 motorized
wire crimp pull tester

MARK-10

TT03 Torque gauge

Designed for clockwise and counter-clockwise torque testing. Capacities from 10 ozFin to 100 lbFin. Dedicated torque sensor with Jacobs chuck is used to grip a sample, bit or fixture. Hand held or mounted to a test stand. USB output gives continuous or individual readings to a PC. Set point indicators for High, Low, In-range. Analog load bar gives visual indication of applied load.

Part Number	Capacity	Weight	SKU	List
MTT03-10Z	10 ozFin x 0.01 ozFin	1.8 lb	7512	\$ 1,595.00
MTT03-20Z	20 ozFin x 0.02 ozFin	1.8 lb	7513	1,595.00
MTT03-50Z	50 ozFin x 0.05 ozFin	1.8 lb	7514	1,595.00
MTT03-12	12 lbFin x 0.01 lbFin	1.8 lb	7515	1,400.00
MTT03-50	50 lbFin x 0.05 lbFin	1.8 lb	7516	1,400.00
MTT03-100	100 lbFin x 0.1 lbFin	1.8 lb	7517	1,400.00

Cap torque gauge

MTT03C-12	12 lbFin x 0.01 lbFin	2.1 lb	7518	1,690.00
MTT03C-50	50 lbFin x 0.05 lbFin	2.1 lb	7519	1,690.00
MTT03C-100	100 lbFin x 0.1 lbFin	2.1 lb	7520	1,690.00

MARK-10

WT3 Wire crimp pull tester

Wire crimp pull testing. A manual ergonomic lever applies force or a motorized unit will automatically apply load to a selected load or load until the sample breaks. Adjustable wire terminal fixture fits wire sizes up to AWG 3 or 0.25". The motorized tester starts automatically when sample is loaded and returns to home when sample breaks. USB, RS232, Mitutoyo and analog outputs. Save and recall up to 500 test profiles. Pull to a specified load or maintain load for a specified period of time as per UL486A/B.

Part Number	Capacity	Weight	SKU	List
WT3-201 manual	200 lbF	3.1 lb	7521	\$ 2,620.00
WT3-201M motorized	200 lbF	4.2 lb	7522	4,890.00

Options

WF010 Save multiple profiles option for WT3-201M	0.0 lb	7523	895.00
WF011 Pull to load option for WT3-201M	0.0 lb	7524	675.00
WF012 Load holding option for WT3-201M	0.0 lb	7525	1,010.00
WF013 Date & time stamp option for WT3-201M	0.0 lb	7526	620.00
WF014 Complete options package for WT3-201M	0.0 lb	7527	2,080.00
WF3002 Ring terminal fixture for WT3-201 / WT3-201M	1.1 lb	7528	220.00
WF3003 Machinable blank terminal fixture WT3-201/M	1.8 lb	7529	200.00
WF3004 Carrying case for WT3-201	2.9 lb	7530	285.00
WF3004-1 Carrying case for WT3-201M	3.1 lb	7531	285.00
AC1049 Calibration fixture for WT3-201/M (no weights)	2.1 lb	7532	910.00

MARK-10

MTT01 Cap torque tester

The CT captures peak torque in both clockwise and counterclockwise directions for application and removal measurements. Tester features a solid aluminum housing and rugged construction for many years of service in laboratory or production environments. Adjustable posts effectively grip a broad range of container shapes and sizes, while a set of optional jaws is available as an alternative gripping method. Accepts samples up to 7.5" dia. Selectable units of measurement are lbin, kgFmm and Ncm. Movable container gripping posts. Battery or AC operation. Includes set of four posts, AC adapter and 9V non rechargeable battery, 30 hours of continuous operation. Users manual and NIST-traceable certificate of calibration.

Part Number	Capacity	Weight	SKU	List
MTT01-12	12 x 0.01 lbin	10 lb	4514	\$ 1,610.00
MTT01-25	25 x 0.02 lbin	10 lb	4554	1,610.00
MTT01-50	50 x 0.05 lbin	10 lb	4515	1,610.00
MTT01-100	100 x 0.1 lbin	10 lb	4516	1,610.00

Options

CT001 Sample gripping jaws for TT01 pair	1.0 lb	3220	85.00
CT002 Carrying case for TT01	2.1 lb	4256	220.00
CT003 Adjustable gripping jaws for TT01, pair	1.1 lb	4257	395.00
CT004 Set of posts for TT01/R53 1.25" long, set of 4	0.4 lb	4258	170.00
CT005 Set of posts for TT01/R53 2.5" long, set of 4	0.6 lb	4259	195.00
CT006 Set of posts for TT01/R53 4" long, set of 4	0.8 lb	4260	225.00
CT007 Kit of 4 posts of each length, set of 12	1.8 lb	4261	450.00
AC1036 Calibration kit for TT01 (weights not included)	2.7 lb	4262	695.00



MTT01
Cap torque t ester
w/ standard adjustable posts



Optional
Gripping Jaws



Standard
Adjustable Posts

MARK-10

MTT02 Digital torque tester

Simple, yet accurate solution for testing torque screwdrivers, wrenches and other tools. Solid aluminum housing make it rugged enough for many years of service in production or laboratory use. Universal receptacle with square drive and grooves accepts commpn bits and attachments. Applications exist in virtually every industry. Captures peak torque in both clockwise and counterclockwise directions. Selectable units of measure are: lbFin, kgFmm, Ncm. Push button calibration. RS-232 and Mitutoyo (Digimatic). WinWedge software allows the torque tester to send data to a PC for furthur analysis in Windows applications such as Excel. AC or non-rechargeable 9V battery with Intelligent Power Management System (IPM). IPM warns user via "LO BAT" indicator and then will power off the gauge. 30 hours of continuous use.

Part Number	Capacity	Weight	SKU	List
MTT02-12	12 lbin	5 lb	6900	\$ 1,495.00
MTT02-25	25 lbin	5 lb	6808	1,495.00
MTT02-50	50 lbin	5 lb	6901	1,495.00
MTT02-100	100 lbin	5 lb	6902	1,495.00

Options

AC1066-1	Rundown fixture 0-50 lbFin	1 lb	6809	250.00
AC1066-2	Rundown fixture 0-50 lbFin	1 lb	6810	252.00
ST001	Bench mounting bracket	2 lb	6903	170.00
ST002	Carrying case for TT02	2 lb	6811	200.00



MTT02
Digital Torque Tester



MTT05
Torque Tester

MARK-10

MTT05 Torque tester

Universal torque testers have a stainless steel loading surface with conveniently spaced threaded holes for mounting fixtures and attachments. Measures torques up to 100 lbTin. For use in the laboratory or the production floor. USB, RS232, Mititoyo and analog outputs. Data memory, set points and automatic data output. Peak torque detection. Pass fail detection.

Part Number	Capacity	Weight	SKU	List
MTT05-12	12 x 0.01 lbin	10 lb	6813	\$ 1,425.00
MTT05-25	25 x 0.02 lbin	10 lb	6814	1,425.00
MTT05-50	50 x 0.05 lbin	10 lb	6815	1,425.00
MTT05-100	100 x 0.1 lbin	10 lb	6816	1,425.00

Options

CT002	Carrying case for TT05/TT01	2.1lb	4256	220.00
-------	-----------------------------	-------	------	--------



M5I
Torque Indicator



MR01
S-Beam

MARK-10

Plug & Test indicator & sensors

Force and torque indicators

Part Number		Weight	SKU	List
M7I	Professional force/torque indicator	2 lb	5766	\$ 1,740.00
M5I	Advanced force/torque indicator	2 lb	5799	1,025.00
M3I	Basic force/torque indicator	2 lb	5767	675.00
PTA	User configurable adapter w/software	2 lb	5768	275.00

Plug & Test indicator & sensors

Force sensors

Part Number	Capacity	Weight	SKU	List
MR01-50	50 lb	2 lb	5810	\$ 700.00
MR01-100	100 lb	2 lb	5811	700.00
MR01-200	200 lb	2 lb	5812	700.00
MR01-300	300 lb	2 lb	5769	700.00
MR01-500	500 lb	2 lb	5813	700.00
MR01-750	750 lb	2 lb	5770	700.00
MR01-1000	1,000 lb	2 lb	5814	700.00
MR01-1500	1,500 lb	2 lb	5771	700.00
MR01-2000	2,000 lb	2 lb	5815	700.00
MR01-5000	5,000 lb	2 lb	5816	1,000.00
MR01-10000	10,000 lb	2 lb	5817	1,000.00
MR02-100	100 lb	1 lb	5803	880.00
MR02-200	200 lb	1 lb	5804	880.00
MR02-500	500 lb	1 lb	5805	880.00
MR02-1000	1000 lb	1 lb	5806	880.00
MR02-2000	2000 lb	1 lb	5807	880.00
MR02-5000	5000 lb	1 lb	5808	1,000.00
MR02-10000	10000 lb	1 lb	5809	1,000.00

MARK-10

Plug & Test indicator & sensors, continued

Force sensors

Part Number	Capacity	Weight	SKU	List
MR03-025	0.25 lb	1 lb	5818	\$ 915.00
MR03-05	0.5 lb	1 lb	5819	915.00
MR03-22	2 lb	1 lb	5820	765.00
MR03-5	5 lb	1 lb	5821	765.00
MR03-10	10 lb	1 lb	5822	765.00
MR03-20	20 lb	1 lb	5823	765.00
MR03-50	50 lb	1 lb	5824	765.00
MR03-100	100 lb	1 lb	5825	765.00



MR03
Force sensor
compression

MARK-10

MR04 Miniature Force Sensor

Extremely compact force measurement sensor for tensile and compressive loads in a limited space. This sensor features outstanding mechanical overload protection of up to 1,000% of full scale for most applications and threaded holes on two sides for the mounting of attachments or implements. Member of the BGi family interchangeable sensors. Personality module holds all calibration and configuration data. Measures tensile and compressive forces. Mechanical overload protection of up to 200% for SJR50 and SJR100 when used in tension only. Accuracy $\pm 0.2\%$ of full scale ± 1 digit + BGI. NIST traceable certificates of calibration included.

Part number	Capacity	Weight	SKU	List
MR04-025M	0.25 lb	1 lb	6745	\$ 1,750.00
MR04-05M	0.5 lb	1 lb	6746	1,750.00
MR04-2	2 lb	1 lb	6747	1,750.00
MR05-5	5 lb	1 lb	6748	1,750.00
MR04-10	10 lb	1 lb	6749	1,750.00
MR04-20	20 lb	1 lb	6750	1,750.00
MR04-50	50 lb	1 lb	6751	1,750.00
MR04-100	100 lb	1 lb	6752	1,750.00
MR05-500	500 lb	1 lb	6817	875.00
Wire pull force sensor				
MR06-200	200 lb	1 lb	6112	1,840.00



MR04
Tension compression



MR05
Miniature Force Sensor

MARK-10

MR50 Torque sensor, Universal

Bi-directional, small size. Rugged aluminum housing, remote operation. Accuracy: 0.35% FS. NIST traceable calibration certificate included.

Part number	Capacity	Weight	SKU	List
MR50-10Z	10 ozin	1 lb	5850	\$ 1,020.00
MR50-20Z	20 ozin	1 lb	5851	1,020.00
MR50-50Z	50 ozin	1 lb	5852	1,020.00
MR50-12	12 lbin	1 lb	5853	940.00
MR50-50	50 lbin	1 lb	5854	940.00
MR50-100	100 lbin	1 lb	5855	940.00



MR50
Universal torque sensor

Prices are subject to change without notice. Please call for current prices.

Other items are available from the manufacturers, please call for prices.



MR51
Universal torque sensor



MR52
Tool Calibration

MARK-10

MR51 Torque Sensor, Universal

Member of the BGI interchangeable sensors. Outstanding overload protection, interchangeable chucks. Personality module holds all calibration and configuration data. Accuracy: 0.15% FS. NIST traceable calibration certificate included.

Part Number	Capacity	Weight	SKU	List
MR51-10Z	10 ozin	1.lb	5857	\$ 955.00
MR51-20Z	20 ozin	1 lb	5858	955.00
MR51-50 Z	50 ozin	1 lb	5859	955.00
MR51-12	12 lbin	1.lb	5860	880.00
MR51-50	50 lbin	1.lb	5861	880.00
MR51-100	100 lbin	1.lb	5862	880.00

Accessories

G1016-1 Jacobs chuck for STH	0.25"	1 lb	5863	160.00
G1016-2 Jacobs chuck for STH	0.375"	1 lb	5864	155.00
G1016-3 Jacobs chuck for STH	0.5"	1 lb	5865	170.00
G1017 Bit holder for STH, 1/4" hex		1 lb	5866	170.00

MARK-10

MR52 Torque sensor, Tool calibration

Small size, remote operation. Universal mounting, may be used for torque tool calibration or as a component of a torque testing system. Accuracy: 0.35% of full scale. NIST traceable calibration certificate included.

Part Number	Capacity	Weight	SKU	List
MR52-10Z	10 ozin	1 lb	5837	\$ 975.00
MR52-20Z	20 ozin	1 lb	5838	975.00
MR52-50Z	50 ozin	1 lb	5839	975.00
MR52-12	12 lbin	1 lb	5840	910.00
MR52-50	50 lbin	1 lb	5841	910.00
MR52-100	100 lbin	1 lb	5842	910.00

MARK-10

MR55 Torque sensor, Wrench extension

Rugged all metal construction. Converts any wrench to a torque tool. May be used as torque tool or as a component of a torque testing system. Accuracy: 0.6% of full scale NIST traceable calibration certificate included.

Part number	Capacity	Weight	SKU	List
MR55-20	20 x 0.02 lbin	1 lb	6734	\$ 1,375.00
MR55-50	50 x 0.05 lbin	1 lb	6735	1,375.00
MR55-100	100 x 0.1 lbin	1 lb	6736	1,375.00
MR55-200	200 x 0.2 lbin	2 lb	5845	1,375.00
MR55-400	400 x 0.5 lbin	2 lb	5846	1,375.00
MR55-1000	1000 x 0.1 lbin	2 lb	5847	1,375.00
MR55-5000	5000 x 5 lbin	2 lb	5848	1,375.00



MR54
Wrench Extension

MARK-10

Motorized test stands

Single column force tester for tension and compression for use in the laboratory or production floor. Used for break testing, cycling, limit testing to a load or distance, loadholding and elongation. Adjustable test speed, force and distance limits. Data can be output to a PC for analysis.

Part Number	Capacity	Weight	SKU	List
ESM303 Vertical	300 lb	56.5 lb	8364	\$ 3,400.00
ESM303H Horizontal	300 lb	56.5 lb	8365	4,050.00

Options

ESM303-001-1	6" Single column extension	2 lb	8366	440.00
ESM303-001-2	12" Single column extension	4 lb	8367	610.00
ESM303-001-3	24" Single column extension	8 lb	8368	770.00
ESM303-002-1	6" Double column extension	4 lb	8369	1,925.00
ESM303-002-2	12" Double column extension	8 lb	8370	2,200.00
ESM303-002-3	24" Double column extension	16 lb	8371	2,472.00
ESM303-003	Safety shield	10 lb	8372	2,080.00
ESM303-004	Tabletop control panel kit, vertical	10 lb	8373	375.00
ESM303-004-1	Tabletop control panel kit, horizontal	5 lb	8374	135.00
AF008	FollowMe manual positioning		8375	315.00
AF009	Travel indication w/USB output	1 lb	8376	1,150.00
AF010	Computer control via USB		8377	1,150.00
AF011	Programmable travel set points	1 lb	8378	315.00
AF012	Overload protection		8379	315.00
AF013	Auto return		8380	220.00
AF014	Cycling/dwell time		8381	315.00
AF016	Independent up and down speeds		7489	190.00
AF017	Extended speed range, low		7490	220.00
AF018	Extended speed range, high		7491	220.00
AF019	Break detection		7492	220.00
AF020	Load holding		7493	495.00
AF021	Preload/sample touch		7494	315.00
AF022	Profiles		7495	630.00
AFCOMP	Complete options package, vertical		7496	4,540.00
AFCOMP-H	Complete options package, horizontal		7497	4,540.00



ESM303
Motorized test stand
Vertical



ESM303H
Motorized test stand
Horizontal

Prices are subject to change without notice. Please call for current prices.

Other items are available from the manufacturers, please call for prices.

13-01 Pollitt Dr Ext
Fair Lawn NJ 07410
201-797-2718

Totalcomp
Scales & Balances

www.totalcomp.com
sales@totalcomp.com
Fax 201-797-2287

MARK-10

Motorized test stands, continued

Torque testing for closures and fasteners. Vertical and horizontal units. Motorized clockwise and counterclockwise rotation. Settable rotation speed. Constant speed with load changes. Fixture mounting plate with angle indicator. Easy change between angle and torque limits. Custom column lengths.



TSTM-DC
Motorized test stand
Vertical



TSTMH-DC
Motorized test stand
Horizontal



ESM1500
Motorized test stand

Part Number	Capacity	Weight	SKU	List
TSTM-DC Vertical	100 lb	195 lb	840	\$ 8,500.00
TSTMH-DC Horizontal	100 lb	195 lb	841	8,500.00
TSTM-DC-1 Vertical	200 lb	195 lb	842	9,475.00
TSTMH-DC-1 Horizontal	200 lb	195 lb	843	9,475.00
TSTM-DC-2 Vertical, 60RMP	100 lb	195 lb	844	9,200.00
TSTMH-DC-2 Horizontal, 60RMP	100 lb	195 lb	845	9,200.00

Options

SP-2496	Torque upgrade	846	920.00
SP-2624	Speed upgrade	847	690.00
TST002	Angle encoder	848	690.00
TSF002	Wall mounting kit	849	215.00
TSFM500(H)-DC	Column extension 12"	850	360.00
TSTM(H)-DC	Column extension 42"	851	855.00

Part Number	Capacity	Weight	SKU	List
ESM1500LC load cell	1,500 lb	198 lb	6116	\$ 8,700.00
ESM1500FG force gauge	1,500 lb	198 lb	6117	8,700.00
ESM1500SLC load cell	1,500 lb	160 lb	6118	8,140.00
ESM1500SFG force gauge	1,500 lb	160 lb	6119	8,140.00
ESM750LC load cell	750 lb	185 lb	6120	7,570.00
ESM750FG force gauge	750 lb	185 lb	6121	7,350.00
ESM750SLC load cell	750 lb	150 lb	6122	7,050.00
ESM750SFG force gauge	750 lb	150 lb	6123	7,050.00

Options

AC1055	Base plate, matrix	3 lb	6124	135.00
AC1054	Base plate, multiple center	3 lb	6125	135.00
AC1072	Base plate, 1/2-20 center hole	3 lb	6126	135.00
AC1057	Force gauge mounting kit	12 lb	6127	480.00
AC1056	Load cell mounting kit	12 lb	7900	480.00
SF008	FollowMe positioning	7901	565.00	
SF009	Travel indication ESM1500/ESM750	7902	1,985.00	
SF009-1	Travel indication ESM1500S/ESM750S	7903	1,525.00	
SF010	Computer control via USB	7904	1,165.00	
SF011	Programmable travel set points	7905	940.00	
SF012	Overload protection	7906	820.00	
SF013	Auto return	7907	560.00	
SF014	Cycling dwell time	7908	820.00	
SF016	Independent up & down speeds	7909	505.00	
SF017	Extended speed range, low	7910	560.00	
SF018	Extended speed range, high 1500/1500S	7911	560.00	
SF018-1	Extended speed range, high 750/750S	7912	560.00	
SF019	Break detection	7913	560.00	
SF020	Load holding	7914	825.00	
SF021	Preload sample touch	7536	690.00	
SF022	Profiles	7537	940.00	
SFCOMP	Complete options ESM1500/ESM750	7538	6,835.00	
SFCOMP-1	Complete options ESM1500S/ESM750S	7539	6,425.00	

Prices are subject to change without notice. Please call for current prices.

Other items are available from the manufacturers, please call for prices.

MARK-10

Manual test stands

Economical and compact push/pull test stands. Lever action gives quick testing at high speeds, while hand wheel action gives fine positioning and better motion control

Part Number	Capacity	Weight	SKU	List
ES05 Test stand with lever	30 lb	10 lb	5542	\$ 660.00
ES10 Test stand with lever	100 lb	10 lb	5879	660.00
ES20 Test stand with hand wheel	100 lb	10 lb	5880	775.00

Options

ES001	Dial indicator for ES10/ES20	1 lb	5882	170.00
ES002	Digital indicator for ES10/ES20	2 lb	5543	390.00
ES001NI	Brackets for indicator 9.5mm dia	2 lb	5544	140.00
ES001NI-8MM	Brackets for indicator 8mm dia	2 lb	5545	140.00
AC1060	Base plate w/threaded holes	2 lb	5546	90.00

Part Number	Capacity	Weight	SKU	List
ES30 Test stand with hand wheel	200 lb	17 lb	5881	\$ 1,100.00

Options

ESM001	Digital travel display for ES30 6"	1 lb	5885	890.00
ESM004	Digital travel display for ES30 12"	1 lb	5473	1,725.00
ESM003-1	Column extension for ES30 6"	1 lb	5474	180.00
ESM003-2	Column extension for ES30 12"	1 lb	5475	210.00
ESM003-3	Column extension for ES30 24"	1 lb	5476	240.00

Part Number	Capacity	Weight	SKU	List
TSA750 Test stand lever, vertical	750 lb	16 lb	5867	\$ 1,185.00
TSA750H Test stand lever, horizontal	750 lb	13 lb	5868	1,185.00

Options

TSA-1	Digital travel display for TSA	1 lb	5869	785.00
TSA-2	Horizontal wall mount kit for TSA	1 lb	5870	180.00
TSA-3	Table assembly for TSA/TSAH	1 lb	5871	240.00

Part Number	Capacity	Weight	SKU	List
TSB100 Test stand with lever	100 lb	12 lb	5872	\$ 945.00

Options

TSB003	Travel stops kit for TSB	1 lb	5875	110.00
--------	--------------------------	------	------	--------

Part Number	Capacity	Weight	SKU	List
TSC1000 Test stand, wheel, vertical	1,000 lb	25 lb	5876	\$ 1,640.00
TSC1000H Test stand wheel, horizontal	1,000 lb	20 lb	5877	1,640.00

Options

TSC001	Digital travel display for TSC/TSCH	1 lb	5878	780.00
--------	-------------------------------------	------	------	--------

Part Number	Capacity	Weight	SKU	List
TSF Test stand, wheel, vertical	1,000 lb	25 lb	5547	\$ 2,500.00
TSFH Test stand wheel, horizontal	1,000 lb	20 lb	5548	2,500.00

Options

TSF001	Digital travel display for TSF	1 lb	5549	890.00
--------	--------------------------------	------	------	--------

Part Number	Capacity	Weight	SKU	List
TST Test stand, wheel, vertical	100 lb	17 lb	6740	\$ 3,250.00
TSTH Test stand wheel, horizontal	100 lb	17 lb	6741	3,250.00

Options

TST001	Digital travel display for TST/TSTH	2 lb	5550	1,135.00
TST002	Mounting kit for TST/TSTH	4 lb	5551	645.00

TSA/B/C(H)	Column extension 12"		5552	220.00
TSF(H)	Column extension 12"		5553	280.00
TST(H)	Column extension 12"		5554	360.00



ES
Manual test stand



ES30
Manual test stand



TSA
Manual test stand



TSB
Manual test stand



TSC
Manual test stand



TST
Manual test stand

Prices are subject to change without notice. Please call for current prices.

Other items are available from the manufacturers, please call for prices.

13-01 Pollitt Dr Ext
Fair Lawn NJ 07410
201-797-2718

Totalcomp
Scales & Balances

www.totalcomp.com
sales@totalcomp.com
Fax 201-797-2287



EK3



ME force gauge



EKE



G1001
Wire terminal grip

MARK-10

Ergonomics testing kits

For use in muscle strength assessment, ergonomic studies and workplace design.

Part Number	Capacity	Weight	SKU	List
EK3-100 Test kit w/Series 3 gauge	100 lb	12 lb	4534	\$ 1,140.00
EK3-200 Test kit w/Series 3 gauge	200 lb	12 lb	4535	1,140.00
EK3-500 Test kit w/Series 3 gauge	500 lb	12 lb	4536	1,140.00
ME-100 Force gauge	100 lb	3 lb	4537	1,120.00
ME-200 Force gauge	200 lb	3 lb	4538	1,120.00
ME-500 Force gauge	500 lb	3 lb	4539	1,120.00

Options

E1000	Carrying case, small	2 lb	4540	200.00
E1001	Carrying case, large	3 lb	4541	225.00
E1002	Padded attachment, square	2 lb	4542	85.00
E1003	Padded attachment, rectangular	2 lb	4543	95.00
E1004	Padded attachment, curved	2 lb	4544	105.00
E1005	Padded attachment, circular	2 lb	4545	135.00
E1006	Snap hook	2 lb	4546	125.00
E1007	Snap hook chain assy	2 lb	4556	110.00
E1008	Single handle grip	2 lb	4557	110.00
E1009	Double handle grip	2 lb	4558	170.00
E1010	Pistol grip	2 lb	4559	285.00
E1011	Grip adapter	2 lb	4560	55.00
E1012	Looped cable	2 lb	4561	50.00
E1013	Myometer assessor	2 lb	4562	310.00

Part Number	Capacity	Weight	SKU	List
Advanced Ergonomics testing kit				
EKE-100-1 Test kit w/Series E gauge	100 lb	12 lb	4563	\$ 1,570.00
EKE-200-1 Test kit w/Series E gauge	200 lb	12 lb	4564	1,570.00
EKE-500-1 Test kit w/Series E gauge	500 lb	12 lb	4565	1,570.00

Professional Ergonomics testing kit

EKE-100-2 Test kit w/Series E gauge	100 lb	12 lb	4566	2,130.00
EKE-200-2 Test kit w/Series E gauge	200 lb	12 lb	4567	2,130.00
EKE-500-2 Test kit w/Series E gauge	500 lb	12 lb	4568	2,130.00
ME-500 Force gauge	500 lb	3 lb	4739	70.00

MARK-10

Grips

For use with, digital force gauges, digital torque gauges, digital force/torque indicators, and test stands.

Part Number	Weight	SKU	List
G1001	Wire terminal grip 0.000" to 0.125" OD	1 lb	5889 \$ 325.00
G1001-1	Wire terminal grip 0.125" to 0.250" OD	2 lb	5800 325.00
G1001-2	Wire terminal grip 0.250" to 0.375" OD	2 lb	5801 325.00
G1002	Dual roller grip 0" to 0.25"	1 lb	5890 265.00
G1002-1	Dual roller grip 0.10" to 0.34"	2 lb	5802 300.00
G1003	Mini component grip"	1 lb	5891 200.00
G1008	Film and paper grip to 1.25" wide	1 lb	5892 300.00
G1009	Compression plate 2" dia	1 lb	5893 55.00
G1009-1	Compression plate 3" dia	1 lb	5894 90.00

Prices are subject to change without notice. Please call for current prices.

Other items are available from the manufacturers, please call for prices.

MARK-10

Grips, continued

For use with, digital force gauges, digital torque gauges, digital force/torque indicators, and test stands.

Part Number		Weight	SKU	List
G1009-2	Compression plate 2" dia	2 lb	5939	\$ 80.00
G1009-3	Compression plate 3" dia	2 lb	5954	120.00
G1010	Pin vise 0.062" to 0.375" dia	1 lb	5895	120.00
G1010-1	Pin vise 0.028" to 0.25" dia	2 lb	5941	120.00
G1010-2	Pin vise 0.078" to 0.5" dia	2 lb	5942	120.00
G1011	Rubber tip	1 lb	5896	45.00
G1013	Parallel jaw grip	1 lb	5898	255.00
G1015-1	Film and paper grip 3" wide	1 lb	5899	375.00
G1015-2	Film and paper grip 5" wide	1 lb	5900	395.00
G1015-3	Film and paper grip 7" wide	1 lb	5901	425.00
G1016-1	Jacobs chuck for R51 0.028" to 0.25" dia	1 lb	5863	165.00
G1016-2	Jacobs chuck for R51 0.062" to 0.375" dia	1 lb	5864	170.00
G1016-3	Jacobs chuck for R51 0.5" dia	1 lb	5865	175.00
G1017	Bit holder for R51 1.4" dia	1 lb	5905	175.00
G1019	Padded attachment, square	1 lb	5908	55.00
G1020	Padded attachment, rectangular	1 lb	5909	75.00
G1021	Curved padded attachment	1 lb	5910	95.00
G1022-1	Jacobs chuck for TST 0.028" to 0.25" dia	1 lb	6730	215.00
G1022-2	Jacobs chuck for TST 0.062" to 0.375" dia	1 lb	6731	240.00
G1022-3	Jacobs chuck for TST 0.078" to 0.5" dia	1 lb	6732	265.00
G1023	Bottle grip for TST 0.050" to 6.0" dia	1 lb	6733	595.00
G1046	Pneumatic grip	1 lb	5944	715.00
G1053	Univrsal v-jaw grip	1 lb	5945	385.00
G1056	Multi jaw grip	1 lb	5946	350.00
G1058	Cap grip	1 lb	5947	475.00
G1061	Wedge grip 0.75" jaw	1 lb	5948	690.00
G1061-1	Wedge grip 0.375" jaw	1 lb	5949	620.00
G1061-2	Wedge grip 1.0" jaw	1 lb	5950	755.00
G1061-3	Wedge grip 0.75" jaw, rubber face	1 lb	5897	755.00
G1062	Minature wedge grip	1 lb	5196	335.00
G1074	Vice grip	1 lb	5197	370.00
G1071	Score bend fixture set	1 lb	5198	530.00
G1072	Opening force fixture set	1 lb	5199	480.00
G1076	Wire terminal grip turret	1 lb	5200	495.00
G1077	Clevis grip	1 lb	5201	145.00
G1078	Miniature filament grip	1 lb	5202	350.00
G1085	Dual roller grip adjustable	1 lb	5203	475.00
G1086	Coefficient of friction fixture	1 lb	5204	1,785.00
G1087	Compression plate 3.78" dia eye end	1 lb	5205	250.00
G1087-1	Compression plate 2.20" dia eye end	1 lb	5206	120.00
G1089	Syringe fixture	1 lb	5207	1,135.00
G1090	High capacity clevis grip eye end	1 lb	5208	385.00
G1092	High capacity wire rope grip eye end	1 lb	6375	960.00
G1093	High capacity wire terminal grip eye end	1 lb	6376	1,590.00
G1094	High capacity eccentric roller grip eye end	1 lb	6377	1,135.00



G1010
Pin vise



G1013
Parallel jaw grip



G1002
Dual roller grip



G1016-2
Jacobs chuck

Prices are subject to change without notice. Please call for current prices.

Other items are available from the manufacturers, please call for prices.

13-01 Pollitt Dr Ext
Fair Lawn NJ 07410
201-797-2718

Totalcomp
Scales & Balances

www.totalcomp.com
sales@totalcomp.com
Fax 201-797-2287

MARK-10

Grips, continued

For use with, digital force gauges, digital torque gauges, digital force/torque indicators, and test stands.

Part Number		Weight	SKU	List
G1095	Bend fixture eye end	1 lb	6378	960.00
G1096	High capacity bend fixture eye end	1 lb	6379	1,300.00
G1097	Upper anvil for bend fixture eye end	1 lb	6380	180.00
G1098	Loop tack fixture	1 lb	6381	980.00
G1100	Parallel jaw grip large eye end	1 lb	6382	710.00
G1101	Parallel jaw grip medium eye end	1 lb	6383	390.00
G1102	Wire rope grip large eye end	1 lb	6384	710.00
G1103	Wire rope grip medium eye end	1 lb	6385	455.00
G1104	Flip cap grip	1 lb	6386	180.00
G1105	Cork extracion fixture	1 lb	6387	1,430.00
G1106	Vise grip self centering	1 lb	6801	890.00
G1107	Snap hook	1 lb	6802	130.00
G1109	90 degree peel fixture	1 lb	6803	2,140.00
G1110	Puncture fixture eye end	1 lb	6804	2,915.00
G1111	Ribbon grip eye end	1 lb	6805	860.00



G1003
Mini component grip



G1017
Bit holder

MARK-10

Attachments

For use with, digital force gauges, digital torque gauges, digital force/torque indicators, and test stands.

Part Number		Weight	SKU	List
G1024	Extension rod 5" 10-32	1 lb	5911	20.00
G1031	Extension rod 5" 5/16-18	1 lb	5921	25.00
G1024-1	Extension rod 2" 10-32	1 lb	5912	20.00
G1031-1	Extension rod 2" 5/16-18	1 lb	5922	25.00
G1024-2	Extension rod 1" 10-32	1 lb	5913	20.00
G1031-2	Extension rod 1" 5/16-18	1 lb	5923	25.00
G1025	Chisel point 10-32	1 lb	5914	20.00
G1032	Chisel point 5/16-18	1 lb	5924	25.00
G1026	Cone point 10-32	1 lb	5915	20.00
G1033	Cone point 5/16-18	1 lb	5925	25.00
G1027	V-groove 10-32	1 lb	5916	20.00
G1034	V-groove 5/16-18	1 lb	5926	25.00
G1029	Flat head 10-32	1 lb	5919	20.00
G1036	Flat head 5/16-18	1 lb	5928	25.00
G1028	Hook small 10-32	1 lb	5917	20.00
G1038	Hook medium 10-32	1 lb	5930	15.00
G1035	Hook large 5/16-18	1 lb	5927	25.00
G1042	Hook extra large 1/2-20	1 lb	6806	30.00
G1030	Adapter 5/16 to 10-32	1 lb	5920	20.00
G1037	Coupling 5/16-18	1 lb	5929	20.00
G1039	Coupling 10-32	1 lb	5931	15.00
G1040	Adapter 5/16 to 5/16-18	1 lb	5932	20.00
G1041	Adapter 5/16 to 1/2-20	1 lb	5933	20.00
G1018-1	Adapter # 10-32 UNF 200 lb	1 lb	5906	70.00



8G1008
Film & paper grip

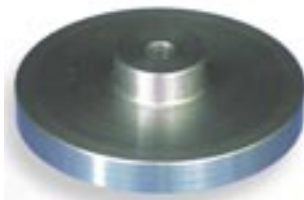

G1009
Compression plate

Prices are subject to change without notice. Please call for current prices.

Other items are available from the manufacturers, please call for prices.

MARK-10

Attachments, continued

For use with, digital force gauges, digital torque gauges, digital force/torque indicators, and test stands.

Part Number		Weight	SKU	List
G1018-2	Swivel adapter 5/16-18 UNC 500 lb	1 lb	5907	\$ 70.00
G1044	Adapter plate TSF/TST 1/2-20F	1 lb	6229	55.00
G1047	Adapter 10-32-to M4F	1 lb	6230	20.00
G1048	Adapter M4M to 10-32	1 lb	6231	20.00
G1049	Adapter M6M to 5/16-18	1 lb	6232	20.00
G1050	Adapter 4-40M to 10-32F	1 lb	6233	20.00
G1051	Adapter4-40M to 10-32M	1 lb	6234	20.00
G1054	Adapter 10-32F to M6M	1 lb	6235	20.00
G1055	Adapter G1053 to stand	1 lb	6236	55.00
G1057	Adapter M6F to 10-32F	1 lb	6237	20.00
G1059	Adapter 5/16-18F to 1/2-20F	1 lb	6238	20.00
G1060	Adapter 10-32M to 10-32M	1 lb	6239	20.00
G1063	Adapter10-32M to 10-32F	1 lb	6240	20.00
G1066	Adapter 5/16-18F to 1/2-20M	1 lb	6756	20.00
G1067	Adapter 1/2-20M to 10-32F	1 lb	6757	20.00
G1068	Adapter G1023 to G1045	1 lb	6758	80.00
G1069	Adapter 5/16-18F to 1/4-28M	1 lb	6759	20.00
G1091	Coupling 1/2-20 F/F	1 lb	6760	10.00
G1113	Adapter M3M to 4-40F	1 lb	6761	20.00
AC1082	Stud jam nut set 10-32	1 lb	6762	10.00
AC1082-1	Stud jam nut set 5/16-18	1 lb	6763	10.00
AC1082-2	Stud jam nut set 1/2-20	1 lb	6764	10.00



90 degree peel fixture



Cork extraction

MARK-10

Eye end adapters

For use with, digital force gauges, digital torque gauges, digital force/torque indicators, and test stands.

Part Number		Weight	SKU	List
G1079	Lock ring	1 lb	6765	\$ 22.00
G1080	Anchor pin	2 lb	6766	22.00
G1081	Eye end 10-32M	2 lb	6767	32.00
G1081-1	Eye end 5/16-18M	2 lb	5415	32.00
G1081-2	Eye end 1/2-20M	2 lb	5416	32.00
G1081-3	Eye end 1/4-28M	2 lb	5417	32.00
G1082	Eye end 10-32F	2 lb	5418	32.00
G1082-1	Eye end 5/16-18F	2 lb	5419	32.00
G1083	Eye end adapter 10-32M	2 lb	5420	32.00
G1083-1	Eye end adapter 5/16-18M	2 lb	5421	32.00
G1083-2	Eye end adapter 1/2-20M	2 lb	5422	32.00
G1084	Washer 0.20"	2 lb	5423	22.00
G1084-1	Washer 0.32"	2 lb	5424	22.00
G1084-2	Washer 0.51"	2 lb	5425	22.00
G1088	Spanner wrench	2 lb	5787	60.00
AC1047	Base/load cell adapter kit 10-32M	2 lb	5788	85.00
AC1047-1	Base/load cell adapter kit 5/16-18M	2 lb	5789	85.00
AC1047-2	Base/load cell adapter kit 1/2-20M	2 lb	5790	85.00



Snap hook



Puncture fixture

Prices are subject to change without notice. Please call for current prices.

Other items are available from the manufacturers, please call for prices.

MARK-10

Eye end adapters, continued

For use with, digital force gauges, digital torque gauges, digital force/torque indicators, and test stands.



09-1162
Cable

Part Number		Weight	SKU	List
G1047-3	Base/load cell adapter kit 1/4-28M	1 lb	5711	\$ 70.00
G1047-4	Load cell adapter R03 10-32M	2 lb	5792	95.00
G1046	Pneumatic grip 10-32F	2 lb	5793	695.00
G1046-1	Grip adapter kit 5/16-18M	2 lb	5794	50.00
G1046-2	Grip adapter kit 1/2-20M	2 lb	5795	35.00
G1045	Force gauge adapter 10-32F	2 lb	5796	95.00
G1045-1	Force gauge adapter 5/16/18F	2 lb	5797	85.00
G1045-2	Force gauge adapter 1/2-20M	2 lb	5718	85.00

MARK-10

Cables & communication adapters

For use with, digital force gauges, digital torque gauges, digital force/torque indicators, and test stands.



09-1066
Mitutoyo

Part Number		Weight	SKU	List
09-1214	Multi function cable 7/5/4 to ESM303	1 lb	5724	\$ 135.00
09-1252	Multi function cable 7/5 to ESM303H	1 lb	5725	135.00
09-1162	Multi function cable 7/5/4 to ESM301	1 lb	7514	145.00
09-1158	USB cable B to A	1 lb	5727	30.00
09-1163	Cable serial 7/5/4 to RS232 DB9	1 lb	7652	80.00
09-1164	Cable 5/4 to Mitutoyo	1 lb	7653	80.00
09-1165	Cable USB 7/5/4/3 to PC	1 lb	5764	30.00
09-1166	Cable analog 7/5/4	1 lb	7654	80.00
09-1056	Serial cablestand to PC	1 lb	5713	30.00
09-1162	Multi function cable gauge to stand	1 lb	5714	135.00
09-1066	Cable Mitutoyo	1 lb	5940	80.00
RSU100	Communications adapter RS232 to USB	1 lb	5849	135.00
MU100	Adapter Mitutoyo to RS232 9pin	1 lb	5943	350.00

Legacy cables

For use with, digital force gauges, digital torque gauges, digital force/torque indicators, and test stands.



MU100
Adapter Mitutoyo

Part Number		Weight	SKU	List
09-1047	Cable legacy gauge to Mitutoyo	1 lb	5856	\$ 80.00
09-1048A	Cable serial to PC DB-9	1 lb	5937	80.00
09-1049	Cable analog dual banana plug	1 lb	5938	80.00
09-1143	Muilti function cable	1 lb	5967	135.00

Software

For use with, digital force gauges, digital torque gauges, digital force/torque indicators, and test stands.

Part Number		SKU	List
15-1004	MESUR gauge single license	7704	\$ 560.00
15-1004-5	MESUR gauge 5 licenses	7705	2,265.00
15-1005	MESUR gauge Plus	7706	710.00
15-1005-5	MESUR gauge Plus 5 licenses	7707	2,810.00
15-1006	Upgrade MESUR gauge to MESUR gauge Plus	7708	225.00

Prices are subject to change without notice. Please call for current prices.

Other items are available from the manufacturers, please call for prices.

MARK-10

Accessories & related items

For use with, digital force gauges, digital torque gauges, digital force/torque indicators, and test stands.

Part Number		Weight	SKU	List
08-1026	Replacement battery 8.4V NiMH	2 lb	5951	\$ 20.00
AC1030	AC adapter/charger 110V US	2 lb	5952	45.00
AC1031	AC adapter/charger 220V Europe	2 lb	5953	45.00
AC1032	AC adapter/charger 220V UK	2 lb	5979	45.00
AC1035	AC adapter/charger 220V Australia	2 lb	5980	45.00
AC1002	Handle grip 7/5/4 double grip	2 lb	5955	145.00
AC1002-1	Handle grip 7/5/4 single grip	1 lb	5956	130.00
AC1003	Handle grip 2/3 double grip	1 lb	5957	115.00
AC1003-1	Handle grip 2/3 single grip	1 lb	5958	95.00
AC1004	Mounting kit indicator TT03 to TS	1 lb	5705	95.00
AC1006	Mounting kit R52	1 lb	5843	75.00
AC1007	Mounting kit R51/TT03	1 lb	5961	100.00
AC1008	Stand indicator TT03	1 lb	5503	160.00
AC1010	Mounting kit MR55	1 lb	5963	125.00
AC1014	Jacobs chuck R52 0.062"-0.375"	2 lb	5844	175.00
AC1014-1	Jacobs chuck R52 0.028"-0.25"	2 lb	5594	175.00
AC1015	Mounting kit R51 to TST	2 lb	5959	75.00
AC1016	Mounting kit R55 to TST	2 lb	5960	75.00
AC1016-1	Mounting kit R55 to TST	2 lb	4210	75.00
AC1018	Mounting kit R01 to TST	2 lb	4211	120.00
AC1019	Air connection kit G1046	1 lb	4212	265.00
AC1044	Maintenance kit G1046	2 lb	4213	110.00
AC1020	Gauge mounting kit DFE	2 lb	4214	110.00
AC1021	Gauge mounting kit DFM	2 lb	4215	110.00
AC1022	Gauge mounting kit DFIS	2 lb	4216	110.00
AC1023	Gauge mounting kit AFG	2 lb	4217	110.00
AC1024	Gauge mounting kit ESM	2 lb	4218	110.00
AC1025	Gauge mounting kit FGV	2 lb	4219	110.00
AC1037	Gauge mounting kit DFE	2 lb	4594	110.00
AC1038	Gauge mounting kit DFM	2 lb	4595	110.00
AC1039	Gauge mounting kit DFIS	2 lb	4596	110.00
AC1040	Gauge mounting kit AFG	2 lb	4597	110.00
AC1041	Gauge mounting kit TSA	2 lb	4598	110.00
AC1042	Gauge mounting kit FGV	2 lb	4599	110.00
AC1061	Gauge mounting kit TCD	2 lb	4600	90.00
AC1069	Gauge mounting kit Mecmesin	2 lb	4601	90.00
AC1029	Axial compressor	2 lb	4602	230.00
AC1043	HI Lo limits indicator	2 lb	4603	125.00
AC1036	Calibration kit TT01 (no weights)	2 lb	4262	700.00
AC1049	Calibration kit WT3-201/M (no weights)	2 lb	7532	1,000.00
AC1051	Foot switch 7/M71	2 lb	7455	205.00
AC1052	Mounting plate 500 lb	2 lb	7456	60.00
AC1058	Mounting plate 2,000 lb	2 lb	7457	90.00
AC1053	Set 4 blanks G1089 syringe fixture	2 lb	7458	175.00
AC1062	Mounting kit indicator load cell ESM	2 lb	7459	265.00



AC1002
Handle grip



AC1014
Jacobs chuck STC



AC1006
Mounting kit R52



AC1008
Indicator stand TT03

Prices are subject to change without notice. Please call for current prices.

Other items are available from the manufacturers, please call for prices.

MARK-10

Accessories & related items, continued

For use with, digital force gauges, digital torque gauges, digital force/torque indicators, and test stands.

Part Number		Weight	SKU	List
AC1064	Load cell mounting hardware ESM303	2 lb	8421	\$ 60.00
AC1065	Load cell mounting hardware ESM1500/750	2 lb	8422	100.00
AC1067	Rollers for bend fixtures 1mm set of 4	2 lb	8423	90.00
AC1067-1	Rollers for bend fixtures 2mm set of 4	2 lb	8424	890.00
AC1067-2	Rollers for bend fixtures 5mm set of 4	2 lb	8425	90.00
AC1067-3	Rollers for bend fixtures 10mm set of 4	2 lb	7804	90.00
AC1068	Test strips G1098	2 lb	7805	175.00
AC1070-1	Jaws for G1100 2.36"	2 lb	7806	335.00
AC1070-2	Jaws for G1100 3.94"	2 lb	7807	380.00
AC1071-1	Jaws for G1100 1.18"	2 lb	7808	140.00
AC1071-2	Jaws for G1100 1.97"	2 lb	7809	210.00
AC1071-3	Jaws for G1100 3.15"	2 lb	7810	285.00
AC1071-4	Jaws for G1100 3.94"	2 lb	7811	330.00
AC1073-1	Inline adapter 3/2 force gauge	2 lb	7812	120.00
AC1073-2	Inline adapter 7/5/4 force gauge	2 lb	7813	155.00
AC1073-3	Inline adapter E force gauge	2 lb	8321	155.00
AC1074	Remote emergency switch ESM	2 lb	8322	295.00
AC1076-1	Mounting posts G1086 ESM750	2 lb	8323	60.00
AC1076-2	Mounting posts G1086 ESM1500	2 lb	8324	60.00
AC1077	Connector covers kit TT01	2 lb	8325	25.00
AC1078	Adjustable angle pulley adapter G1109	2 lb	8326	450.00
AC1079	Adjustable angle mount G1109	1 lb	8327	525.00
AC1080	Adapter G1023 to G1109	1 lb	8328	150.00
AC1087	Adapter G1109 to ESM	1 lb	8329	175.00
20-1025	Chuck key 1/2	1 lb	8330	10.00
20-1025-1	Chuck key 1/4 3/8	1 lb	8331	10.00



AC1062
Mounting kit indicator ESM



Calibration kit

MARK-10

Services

For use with, digital force gauges, digital torque gauges, digital force/torque indicators, and test stands.

Part Number		SKU	List
SVC001	Calibration w/NIST certificate	5965	\$ 260.00
SVC006	Load cell w/cal, NIST cert.	5968	450.00
SVC008	Sensor w/cal, NIST cert	5970	610.00
SVC013	Non warranty repair force or torque	5756	240.00
SVC009	Gauge non warranty repair	5757	160.00
SVC011	Evaluation fee if quoted repair charge is refused	5758	95.00
SVC014	UpgradeBGI to Plug & test w/NIST cert	5759	295.00
CERT	NIST certificate with data	5760	85.00

International Wire Transfers

Beneficiary Bank ConnectOne Bank
 Beneficiary Bank Address 301 Sylvan Ave Englewood Cliffs NJ 07632
 Beneficiary Bank Swift # CENOUS33

Beneficiary Name Totalcomp Inc
 Beneficiary Address 13-01 Pollitt Dr Ext Fair Lawn NJ 07410
 Beneficiary Customer # xxxxxxxxxxxx

Please contact us for Customer Account #.

Domestic ACH (Automated Clearing House)

Bank Name ConnectOne Bank
 Bank Address 301 Sylvan Ave Englewood Cliffs NJ 07632
 Bank ABA # 021213944

Beneficiary Name Totalcomp Inc
 Beneficiary Address 13-01 Pollitt Dr Ext Fair Lawn NJ 07410
 Beneficiary Account # xxxxxxxxxxxx

Please contact us for Customer Account #.

Tarjetas de Crédito

El despacho se hará el mismo día

Solo aceptamos VISA y MASTERCARD

Nota: Proveer siempre el número de cuenta y la Fecha de Vencimiento.

Estimado cliente tener en cuenta que: Mastercard y Visa cobran el 3.15% mas \$1.15 por transacción. Estos costos serán agregados a su factura.

Con Cheque

Cheque de banco de USA o Money Order.

Despachamos cuando el cheque arribe a nuestras oficinas. Por ejemplo si lo envián por servicio courier como DHL o FedEx, el cheque llegaría en 2 ó 3 días a Totalcomp.

Cheque a nombre de: Totalcomp Inc

Enviarlo a: Totalcomp Inc
 13-01 Pollitt Dr Ext
 Fair Lawn NJ 07410
 USA

Cheque por fax/email

Agilizan sus ordenes de compras

En Totalcomp ahora tenemos el nuevo sistema de cheques por fax que permitira el despacho de los productos el mismo día. Tambien agiliza los pagos de facturas vencidas, y ahorra gastos de transferencia y de courier cuando envian un cheque a nuestras oficinas.

¿Como trabaja?

Ustedes consiguen un cheque de un banco local con nexos bancarios Norteamericanos en Dólares Americanos y lo envían vía fax a Totalcomp, con una autorización firmada por el dueño de la cuenta que diga lo siguiente:

Este cheque autoriza cargar a nuestra cuenta la suma de \$ _____

Una vez que lo tengamos tomaremos el número de cuenta del cheque, el número de tránsito y el número MICR que identifica el banco original. Luego imprimimos un cheque con esos datos y lo depositamos normalmente. Esta transaccion es completamente legal y es permitida en los Estados Unidos.

Una vez que tengamos el cheque por fax podremos despachar el mismo día. Ustedes se ahorran los gastos de DHL, FEDEX, tranferencia, o cargos del 2.8% cuando pagan con Visa o MasterCard.

Terms

Terms

Your choice of payment.

1. Check or money order with order.
2. Net 30 days for approved credit customers. If you desire a Totalcomp charge account, simply request a credit application with your next order (or at any time) and we will ship your order when your credit is approved.
3. C.O.D. will be delivered by UPS or Federal Express. They will collect total charges which will include merchandise, freight and handling.

Prices are FOB Fair Lawn, New Jersey or FOB Factory and are subject to change without notice. Orders will be filled with prices in effect at the date of shipment. Minimum order is \$20.00 excluding shipping charges.

Stock

Your components will be shipped within 24 hours from when we receive your order. We normally carry an ample supply of every item on our stock shelf. It is very infrequent that our supply is depleted to zero due to unusual requests from our other customers.

Shipping

- UPSYour order will be shipped UPS whenever possible, unless you request a different method of shipment. Maximum 150 lbs per carton.
- UPS 2nd day airAir freight via UPS. It is a guaranteed 2-day delivery not including Saturday or Sunday.
- UPS 3 day airGround service via UPS. It is guaranteed 3 day delivery not including Saturday and Sunday.
- UPS Next day airAir freight via UPS. It is a guaranteed 1-day delivery not including Sunday.
- Express mailAir freight via U S Postal Service. Guaranteed next day delivery not including Sunday.
- Air FreightAir freight via Federal Express, DHL and other independent air cargo service. Normally next day service. Extra cost for Saturday delivery. No Sunday deliveries.
- TruckWhen shipping load cells and other parts by truck specify shipping class as SCALES NOI CLASS 85.

Warranty

Your Customer Warranty is the standard manufacturer's warranty, which is normally 1 year from date of shipment.

No prior return authorization is required.

Return to us the defective items. Enclose a note with the model number, serial number, invoice number and date of purchase and a brief description of defect.

Defective part will be forwarded to the manufacturer for evaluation. Customer will be advised of the status.

No credit will be issued unless offered by the manufacturer.

Return Policy

All merchandise must be authorized prior to return. No return will be accepted without a **Return Authorization Number**, except for warranties.

If the wrong part was ordered:

1. A 20% restocking charge plus shipping charges will apply.
2. The merchandise being returned must be returned within 2 weeks of original shipping date.
3. The Merchandise being returned must be unused and received in new condition. If merchandise appears to have been used or received in poor or damaged condition, a refurbishing charge will be applied before credit is given.

If the wrong part was shipped:

1. The correct merchandise will be shipped at once.
2. Full credit will be issued upon return of incorrect merchandise.

Damaged in Shipment

Merchandise that has been damaged in shipment must be reported to the freight carrier immediately.

Do not return the merchandise until after the freight carrier has inspected the damage. Keep all the original packaging material for the inspection. The freight carrier will not honor a claim for damage if the merchandise is not as you received it.

After the freight carrier has inspected the damage and has given us approval, we will give you a **Return Authorization Number**.

Email

- sales@totalcomp.com
- purchasing@totalcomp.com
- accountspayable@totalcomp.com
- accountsreceivable@totalcomp.com

Prices are subject to change without notice. Please call for current prices.

Other items are available from the manufacturers, please call for prices.

110ES 132
 110RH-WL 131
 1119-DO 180
 1124 187
 1610-00 181
 1650-00 181
 1704B 176
 2200 51
 2200CW 80
 235 116
 2400-11 180
 30007 126
 310 181
 311 181
 337 102
 400KL 102
 4300 81
 5-0-2 185
 500703-0013 119
 520B 96
 64 92
 6550 100
 6855 100
 7000 51
 7000XL 50
 710 179
 7300 65
 7400 49
 7500 87
 7600 87
 762 96
 8000XL 52
 8001-MA 184
 8011-MA 184
 80410-00 183
 820 116
 8260DD-T-H 117
 854F 186

A

A&D, AD-1683 167
 A&D, AD-4212A 136
 A&D, BM 164
 A&D, EJ 10
 A&D, EK 7
 A&D, EK-G 10
 A&D, EK-i 7
 A&D, EK-L 155
 A&D, EW 8
 A&D, FCi 84
 A&D, FG 28
 A&D, FS-i 79
 A&D, FV 9
 A&D, FW 9
 A&D, FX-i 135
 A&D, FX-iWP 137
 A&D, FZ-i 137
 A&D, FZ-iWP 136
 A&D, GF-A 138
 A&D, GF-P 138

A&D, GH 165
 A&D, GP 156
 A&D, GR 166
 A&D, GX 133
 A&D, GX-A 134
 A&D, HCi 83
 A&D, HD 83
 A&D, HL 5
 A&D, HLi 5
 A&D, HR-AZ/HR-A 164
 A&D, HT 6
 A&D, HV 25
 A&D, HV-G 27
 A&D, HV-WP 27
 A&D, HW-CEP 94
 A&D, HW-G 26, 27
 A&D, MC 163
 A&D, MF 151
 A&D, ML 151
 A&D, MS 151
 A&D, MX 151
 A&D, SC 29
 A&D, SE 29
 A&D, SJ 6, 11
 A&D, SK 11
 A&D, SK-WP 9
 A&D, SW 30
 A520BT 96
 ABW 12
 Acculab, ALC 139
 Acom, PW-200 69
 AD-1683 167
 AD-4212A 136
 Adam, CCT 85
 Adam, CPW 30
 Adam, EBL 139
 Adam, GFC 85
 Adam, HCB 140
 Adam, IHS 125
 Adam, LBX 12
 Adam, LHS 125
 Adam, PGL 139
 Adam, PGWe 162
 Adam, SHS 119
 Adam, WBW 12
 Adventurer service parts 145
 ALC 139
 Analytical 162, 163, 164, 165, 166, 167, 168,
 169, 170, 171, 172, 173, 174, 175
 Animal 95
 Anyload, 100ES 132
 Anyload, 100RH-WL 131
 AP1 71
 APS 51
 AV 144
 AW-WLG 68
 AW-WSM 68
 AWT05 126
 AX 143, 169
 AY123 149

B

Baggage 91, 92, 93
 BCS 24
 Bench 6, 7, 8, 9, 10, 11, 12, 13, 14, 15, 16,
 17, 18, 19, 20, 21, 22, 23, 24
 Bench/Floor 25, 26, 27, 28, 29, 30, 31, 32, 33,
 34, 35, 38, 39, 40, 41, 42, 43, 44, 45, 46, 47,
 48, 49, 50, 51, 52, 53, 54, 55, 56
 Benchmark 176
 BG2 195
 BM 164
 Brecknell, 235 116
 Brecknell, CS 124
 Brecknell, Electro Samson 118
 Brecknell, PS500 95
 BW 54

C

C 90
 C11P 32
 Cardinal, C 90
 Cardinal, CIM 78
 Cas, AP1 71
 Cas, BW 54
 Cas, Caston II 122
 Cas, Caston III 123
 Cas, CCB 121
 Cas, CL5000 73
 Cas, CL5500 73
 Cas, CPS 108
 Cas, DL 54
 Cas, EB 75
 Cas, EC 86
 Cas, EC2 86
 Cas, ED 13
 Cas, LP-1000 72
 Cas, NC1 121
 Cas, PB 55
 Cas, PD-II POS 65
 Cas, RW-2601P 112
 Cas, RW-S/L 111
 Cas, S2000 75
 Cas, S2000JR 74
 Cas, SC 86
 Cas, SW 15
 Cas, SW-RS 14
 Cas, SW-W 15
 Cas, SW-Z 14
 CAST2-PLUS 122
 Caston III 123
 CCB 121
 CCI, FS 178
 CCT 85
 Chatillon, 8260DD-T-H 117
 Chatillon, IN-50 117
 CIM 78
 CK-10 78
 CL5000 73
 CL5500 73

Index

Compact 2, 3, 4, 5
Computing 71, 72, 73, 74, 75, 76, 77
Counting 82, 83, 84, 85, 86, 87, 88, 89, 90
Covers 190, 191
CPS 108
CPW 30
CQ 45
CR 4
Crane 119, 120, 123, 124, 125
CS 124
CS1500 120
CS200 119
CS750 120
CW250 62
CX 3

D

D31P 33
D32XW 34
D33P 35
D33XW 36, 37
D51P 38
D52P 42, 44
D52XW 39, 40, 41, 43
D71P 44
DCS-CD 117
Detecto, 6500 100
Detecto, Low Profile 31
Detecto, Personal Scale 100
Detecto, Physician Scale 102
Detecto, Portable Beam 186
Detecto, RW 63
Detecto, TB 176
DFD32 60
Dial type spring scales 184
Dillon, AP 126
Dillon, ED junior 127
Dillon, EDxtreme 127
Dillon, Quick-Check 126
DL 54
DLP-300 77
DMS 93
Doran, 2200 51
Doran, 2200CW 80
Doran, 4300 81
Doran, 7000 51
Doran, 7000XL 50
Doran, 7400 49
Doran, 8000XL 52
Doran, DBS 93
Doran, DMS 93
Doran, DS2100 103
Doran, DS5250 104
Doran, MVP 52
Doran, PC400 66
Doran, PC500 67
Doran, PFS7000 60
DP-6900 53
DR 31
DS 93

DS2100 103
DS5250 104
Dynamometer 127, 128, 129, 130, 131, 132
Dynamometers 126

E

EB 75
EBL 139
EC 86, 88
EC2 86
ED 13
EDjr 127
EDx 127
EJ 10
EK 7
EK-G 10
EK-L 155
EK3 204
Electro Samson 118
EP 141
ES 33, 203
ESM 201, 202
EW 8
EX 142, 159, 168
EX1 170

F

Fairbanks, 1124 187
Fairbanks, Portable Beam Scale 187
FCi 84
FD 66
FG 28
First Weigh, CK-10 78
Floor 57, 58, 59, 60, 61, 62
FormasDePago 211
FS 178
FS-i 79
FV 9
FW 9
FX 135
FX-iWP 137
FZ 137
FZ-iWP 136

G

GF-A 138
GF-P 138
GFC 85
GH 165
GL 55
Globe Scientific, Weighing Dishes 189
GP 156
GR 166
grip 204, 206
GX 133
GX-A 134

H

Hanging 116, 117, 118
Hazardous 94
HC 83
HCB 140
HD 83
Health 96, 97, 98, 99, 100, 101, 102
Healthometer, 400 102
HH 2
HI 150
HJ 182
HL 5
HR 164
HT 6
HV 25
HV-G 27
HV-WP 27
HW 25, 26
HW-CEP 94
HW-G 27

I

IHS 125
IN-50 117
Index 213, 214, 215, 216
Industrial 155, 156, 157, 158, 159, PB 160, 161
Intercomp, CS1500 120
Intercomp, CS200 119
Intercomp, CS750 120
Intercomp, CW250 62
Intercomp, LP600 113
Intercomp, PT300 115
Intercomp, PT300DW 114
Intercomp, PW800 108
Intercomp, SW 110
Intercomp, TL6000 129
Intercomp, TL6000-RF 128
Intercomp, TL8500 130

J

JE 107
Jewelry 106, 107
JS 107

L

LBX 12
LC:127 25
LC:4102 26
LC:4103 26
LHS 125
Lift Truck 109
LP-1000 72
LP600 113
LTEF-16 109
LTS, LTEF 109

M

M2 195

M3 194
 M4 194
 M5 192
 M7 193
 MA35 154
 Mark-10 193, 194, 195, 196, 197, 198, 200, 201, 202, 203, 204, 205, 206, 207, 208, 209, 210
 Mark-10, Accessories 209, 210
 Mark-10, Attachments 206, 207
 Mark-10, BG 195
 Mark-10, Cables & communication 208
 Mark-10, Ergonomics 204
 Mark-10, Eye end adapters 207, 208
 Mark-10, Grips 204, 205, 206
 Mark-10, Legacy cables 208
 Mark-10, M2 195
 Mark-10, M3 194
 Mark-10, M4 194
 Mark-10, M5 192
 Mark-10, M7 193
 Mark-10, Manual test stands 203
 Mark-10, Motorized test stands 201, 202
 Mark-10, MR04 199
 Mark-10, MR50 199
 Mark-10, MR51 200
 Mark-10, MR52 200
 Mark-10, MR55 201
 Mark-10, MTT01 197
 Mark-10, MTT02 197
 Mark-10, MTT05 198
 Mark-10, Plug & Test indicator & sensors 198, 199
 Mark-10, Services 210
 Mark-10, Software 208
 Mark-10, TT03 196
 Mark-10, WT3 196
 MB 152
 MB200 152
 MB23 153
 MB27 153
 MB45 152
 MB90 153
 MBS 98
 MC 163
 ME 204
 Mechanical 179, 180, 181, 182, 183, 184, 185, 186, 187
 Mechanical Portion 176, 177, 178
 MF 151
 MH-200 4
 ML 151
 Moisture 151, 152, 153, 154
 MR 198
 MR03 199
 MR04 199
 MR50 199
 MR51 200
 MR52 200
 MR55 201
 MS 151

MSI, hanging scale 119
 MSI, Service parts 124
 MTT01 197
 MTT02 197
 MTT05 198
 MVP 52
 MVS1 55
 MW1P 147
 MX 151

N

NC1 121
 NCI scales service parts 105
 NV 145, 157
 NVT 158

O

Ohaus Adventurer Analytical, AX 169
 Ohaus Adventurer Precision, AX 143, 145
 Ohaus Analytical, EX 170
 Ohaus Analytical, PX 172
 Ohaus Explorer Industrial, EX 159
 Ohaus Explorer Precision, EX 142
 Ohaus Explorer Pro, EP 141
 Ohaus Navigator Industrial, NV 157
 Ohaus Navigator Precision, NV 145
 Ohaus Semi Micro, EX 168
 Ohaus Semi Micro, PX 172
 Ohaus, AV 144
 Ohaus, Catapult 1000 32
 Ohaus, Cent-O-Gram® 181
 Ohaus, CQ31 45
 Ohaus, CR 4
 Ohaus, CX 3
 Ohaus, Defender 3000 34, 35, 36, 37, 60
 Ohaus, Defender 5000 39, 40, 41, 42, 43, 44
 Ohaus, Defender 5000 Square 38
 Ohaus, Dial type spring 184
 Ohaus, Dial-O-Gram® 181
 Ohaus, Digital Field Test 33
 Ohaus, EC 88
 Ohaus, ES 33
 Ohaus, FD 66
 Ohaus, Field Test 180
 Ohaus, Harvard Junior 182
 Ohaus, Harvard Trip 182
 Ohaus, HH 2
 Ohaus, JE 107
 Ohaus, JS 107
 Ohaus, MB 152
 Ohaus, MB200 152
 Ohaus, MB23 153
 Ohaus, MB27 153
 Ohaus, MB45 152
 Ohaus, MB90 153
 Ohaus, NVT 158
 Ohaus, PA 144
 Ohaus, Pioneer 144
 Ohaus, PR 171
 Ohaus, Primer Balance 183

Ohaus, PS 2
 Ohaus, Pull type spring 184
 Ohaus, Ranger 3000 16
 Ohaus, Ranger 3000 Counting 88
 Ohaus, Ranger 4000 18
 Ohaus, Ranger 4000 Counting 89
 Ohaus, Ranger 7000 18
 Ohaus, Reloading scale 185
 Ohaus, School Balance 183
 Ohaus, Scoops 189
 Ohaus, SD 32
 Ohaus, SJX 106
 Ohaus, Solution Balance 180
 Ohaus, SPX 17
 Ohaus, STX 17
 Ohaus, TAJ 106
 Ohaus, Triple Beam 179
 Ohaus, Triple Beam Junior 179
 Ohaus, Triple Pro 181
 Ohaus, Valor 1000 19
 Ohaus, Valor 2000 20
 Ohaus, Valor 3000 20
 Ohaus, Valor 4000 21
 Ohaus, Valor 7000 22
 Ohaus, VN 59
 Ohaus, VX 58
 Ohaus, YA 106
 Over/Under 78, 79, 80, 81

P

P Spring scale 177
 PA 144
 package 57
 Pallet truck 108
 PB 55
 PC 64
 PC-40L 76
 PC400 66
 PC500 67
 PD-II 65
 Penn Scale, 820 116
 Penn Scale, Heirloom Scale 176
 Penn Scale, P 177
 Penn Scale, PS 70
 Pennsylvania, 64 92
 Pennsylvania, 7300 65
 Pennsylvania, 7500 Counting 87
 Pennsylvania, 7600 Counting 87
 PFS7000 60
 PGL 139
 PGW 162
 Point of Sale 65
 Portion/Food 66, 67, 68, 69
 Postal 105
 PPC-200W-II 68
 PPC-300-II 67
 PPC-300WP-II 67
 PR 171
 Practum 148
 Precision 133, 134, 135, 136, 138, 139, 140,

Index

141, 142, 143, 144, 145, 146, 147, 148, 149, 150
PS 2, 70
PS500 95
PT300 115
PT300DW 114
Pull type spring scales 184
PW-200 69
PW800 108
PX 144, 172

Q

Quintix 174

R

R31P 16
R41ME 18
R71MD 18
Race car 110
Radwag, WLC 146, 161
Radwag, WLY 161
Radwag, WTC 146
RC31P 88
RC41 89
Rice Lake, RLP-S 70
RLP-S 70
RW 63, 111
RW-2601P 112

S

S2000 75
S2000JR 74
Sartorius, CP 147
Sartorius, M-Prove 149
Sartorius, MA35 154
Sartorius, Midrics 147
Sartorius, Practum 148
Sartorius, Quintix 174
Sartorius, Secura 173
Sartorius, Signum 160
Sartorius, TE 149
SB1200 183
SC 29, 86
scoop 189
Scoops 188, 189
SD 32, 182
SE 29
Seca, 762 96
SECURA 173
Service parts for CP 147
Service parts for MSI Crane Scale 124
Setra, HI 150
Setra, SI 150
Setra, Supercount 90
Shimadzu 162
SHS 119
SI 150
SIWADCP 160
SJ 6, 11

SJX 106
SK 11
SK-WP 9
SPS 105
SPX 17
SRP 64
STX 17
supercount 90
SW 14, 15, 30, 110
SW-RS 14

T

T 94
T29 8
T32XW 58
TAJ 106
Tanita, TLC 78
TB 46, 48, 176
TBL 48
TBP 47
TBS 91
TBT 47, 48
TBW 56
TBWS 56
TCM2 82
TDS 61
TE212 149
TEI 31
Terms 212
TFC 190
THS 118
TJ 179
TJA-203 175
TL6000 129
TL6000-RF 128
TL8500 130
TLC 78
TM101 98
TM301 97
TM302 97
TM501 99
TM503 101
TM701 101
TM901 95
TM902 95
Topload 137
Tor-Rey, PC-40L 76
Totalcomp, Baggage Scale Kit 91
Totalcomp, BCS 24
Totalcomp, Clear Flexible Covers 190, 191
Totalcomp, Floor Scale 57
Totalcomp, Hazardous Floor Base 94
Totalcomp, MBS 98
Totalcomp, MH 4
Totalcomp, Scoops 188
Totalcomp, T29 8
Totalcomp, TB 46
Totalcomp, TBL 48
Totalcomp, TBP 47
Totalcomp, TCM2 82

Totalcomp, TEI 31
Totalcomp, THS 118
Totalcomp, TJA 175
Totalcomp, TM101 98
Totalcomp, TM301 97
Totalcomp, TM302 97
Totalcomp, TM501 99
Totalcomp, TM503 101
Totalcomp, TM701 101
Totalcomp, TM901 95
Totalcomp, TM902 95
Totalcomp, TPR 108
Totalcomp, TDS 61
TP2611 181
TPR 108
Transcell, NCI 105
Transcell, PC 64
Transcell, SPS 105
Transcell, SRP 64
TSA 203
TSCP-431 188
TSTM 202
TT03 196
TVD 23
TVP 77
TVS 69

U

UC-321
Wheel Load 112, 113, 114
UPS Shipping 64

V

V22PW 20
V22XW 20
V31X 20
V41PW 21
V41XW 21
V71P 22
Valor 1000 19
Vision Tech, 520B 96
Vision Tech, A520BT 96
Vision Tech, DCS-CD 117
Vision Tech, DLP-300 77
Vision Tech, GL 55
Vision Tech, MVS1 55
Vision Tech, TBW 56
Vision Tech, TBWS 56
Vision Tech, TVD 23
Vision Tech, TVP 77
Vision Tech, TVS 69
VN 59
VX 58

W

weighing dishes 189
Wheel Load 111, 115
WLC 146, 161
WLY 161

WT3 196
WTC 146

Y

YA 106
Yamato, AW-WLG 68
Yamato, AW-WSM 68
Yamato, DP-6900 53
Yamato, PPC-200W-II 68
Yamato, PPC-300-II 67
Yamato, PPC-300WP-II 67



13-01 Pollitt Drive Ext
Fair Lawn NJ
07410
USA

Address Service Requested

BOUND PRINTED
MATTER
U.S. POSTAGE PAID
PARAMUS, NJ
PERMIT 545

Mail Room Supervisor: Our customer at your location has requested this catalog. If this catalog cannot be delivered as addressed, please forward to your company's Purchasing Manager and call us at **800-631-0347** to update the changes.



write

13-01 Pollitt Dr Ext
Fair Lawn NJ 07410

phone

201-797-2718

fax

(201) 797-2287

browse

www.totalcomp.com

e-mail

sales@totalcomp.com